

**KW4M
Eco-POWER METER
User's Manual**

Basic setting to measure by Eco-POWER METER

When wiring the main unit and the current transformer (CT) and setting the basic setting after power on, you can measure the power

The basic setting of MODE1 is necessary to measure.

In order to use the other functions, the settings of the each parameter are necessary.

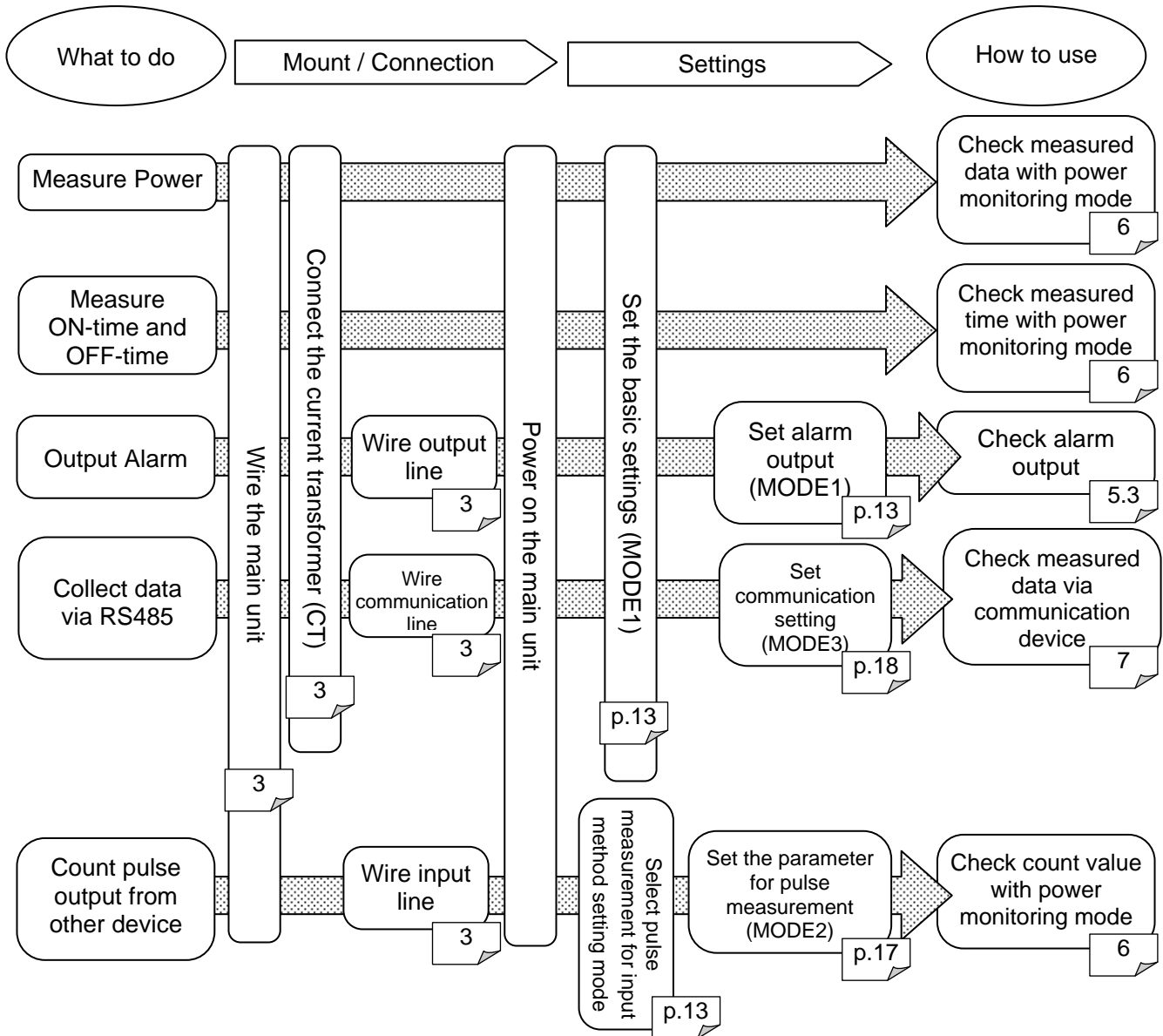

Cautions for Your Safety

Read the manual carefully before installing, running and maintenance for proper operation. Before using, master the knowledge of the equipment, safety information and all of other notes.

This manual uses two safety flags to indicate different levels of danger.



WARNING

A handling error could cause serious physical injury to an operator and in the worst case could even be fatal.

- Always take precautions to ensure the overall safety of your system, so that the whole system remains safe in the event of failure of this product or other external factor.
- Do not use this product in areas with inflammable gas. It could lead to an explosion.
- Exposing this product to excessive heat or open flames could cause damage to the lithium battery or other electronic parts.



CAUTION

A handling error could cause serious physical injury to an operator or damage to the equipment.

- To prevent abnormal exothermic heat or smoke generation, use this product at the values less than the maximum of the characteristics and performance that are assured in these specifications.
- Do not dismantle or remodel the product. It could lead to abnormal exothermic heat or smoke generation.
- Do not touch the terminal while turning on electricity. It could lead to an electric shock.
- Use the external devices to function the emergency stop and interlock circuit.
- Connect the wires or connectors securely. The loose connection might cause abnormal exothermic heat or smoke generation.
- Do not allow foreign matters such as liquid, flammable materials, metals to go into the inside of the product. It might cause exothermic heat or smoke generation.
- Do not undertake construction (such as connection and disconnection) while the power supply is on.
- Do not use at secondary side circuit of inverter. It might cause exothermic heat or damage.

Copyright and trademark

- Panasonic Industrial Devices SUNX Co., Ltd. owns the copyright of this manual.
- We stiffly refuse the reproduction of without permission from this manual.
- Modbus Protocol is a communication protocol that the Modicon Inc. developed for PLC.
- Other company names and the product names are the trademarks or registered trademarks of each company.

Introduction

Thank you for indeed for purchasing “KW4M Eco-POWER METER” for this time.

In this manual, we explain the usage of “KW4M Eco-POWER METER” in detail.

Please use it correctly after understanding the content enough.

Table of Contents

Chapter 1 Unit's Features and Structure	1
1.1 Features.....	1
1.2 Unit's Name and Model Numbers.....	1
1.2.1 Main unit.....	1
1.2.2 Option.....	1
1.3 Measurement items	2
Chapter 2 Parts Name and Working.....	3
2.1 Parts Names	3
2.2 Keys' Function	3
Chapter 3 Wiring	4
3.1 Terminal arrangement	4
3.2 Power measurement.....	5
3.3 Pulse measurement.....	8
3.4 For Output connection	9
3.5 For Wiring terminal.....	9
3.6 RS485 communication.....	10
3.7 Low Voltage Directive	11
Chapter 4 Settings.....	12
4.1 Operation procedure.....	12
4.2 Setting Mode Explanation.....	14
4.2.1 MODE (Select input method)	14
4.2.2 MODE1 (Mode for setting each parameter for power measurement).....	14
4.2.3 MODE2 (Mode for setting each parameter for pulse measurement)	18
4.2.4 5-2-4 MODE3 (Mode for setting of each parameter for serial communication (RS-485)).....	19
4.2.5 MODE4 (Mode for setting of each parameter for optional function)	20
Chapter 5 Various Functions	21
5.1 LOCK mode	21
5.2 CT Direction Notification (POWER Measurement).....	21
5.3 Counter function (PULSE measurement)	21
5.3.1 Output depends on integral electric power.....	21
5.3.2 Output depends on count value	21
5.4 Counter function (Pulse measurement).....	22
5.4.1 Operation mode.....	22
5.4.2 Change the Preset Value	22
Chapter 6 Display of each Value	23
6.1 Instantaneous electric power / Integral Electrical energy	23
6.2 Current	24
6.3 Voltage.....	24
6.4 Electricity Charge.....	25
6.5 Hour Meter	25
6.6 Count Value / Preset Value	26
Chapter 7 Communications	27
7.1 Communication Procedures	27
7.2 Communication timing	27
7.3 MEWTOCOL communication	28
7.3.1 Overview of MEWTOCOL-COM (RS-485).....	28
7.3.2 Data Register List.....	29
7.3.3 Error Codes	30
7.3.4 Command.....	30
7.4 MODBUS (RTU) Communication	32
7.4.1 Overview of MODBUS (RTU).....	32
7.4.2 Data Register List.....	35

Chapter 8 Specifications.....	37
8.1 Main unit	37
8.2 Input Specifications.....	38
8.2.1 Power Input	38
8.2.2 Pulse input specifications	39
8.3 Pulse output (Transistor output) Specifications	39
8.4 Communication Specifications.....	39
8.5 Self-diagnostic function.....	40
8.6 Applicable standard	40
8.7 Dedicated Current Transformer Specifications.....	40
Chapter 9 Mounting	42
9.1 Dimensions	42
9.1.1 Main unit.....	42
9.1.2 Dedicated CT	44
Chapter 10 Q&A	47

Cautions before using

■ Installation environment

◇ Do not use the Unit in the following environments.

- Where the unit will be exposed to direct sunlight and where the ambient temperature is outside the range of -10 to 50 °C.
- Where the ambient humidity is outside the range of 30 to 85 % RH (at 20°C non-condensing) and where condensation might occur by sudden temperature changes
- Where inflammable or corrosive gas might be produced
- Where the unit will be exposed to excessive airborne dust or metal particles
- Where the unit will be exposed to water, oil or chemicals
- Where organic solvents such as benzene, paint thinner, alcohol, or strong alkaline solutions such as ammonia or caustic soda might adhere to the product
- Where direct vibration or shock might be transmitted to the product, and where water might wet the product
- Where the place near high-voltage cable, high-voltage device, power line, power device.
- Where the place near a machinery with transmission function such as amateur radio.
- Where the place near a machinery which occurs the big switching surge

◇ Please use the Unit according to the specifications described in this manual. Otherwise, it may malfunction or cause fire and an electric shock.

- Connect to the power supply in compliance with the rating.
- Refer to the wiring diagram to ensure proper wiring for the power supply, input and output.
- Do not perform wiring or installation with a live line. It may also lead to circuit burnout or fire by way of the secondary CT side opening.

■ Installation

- Installation and wiring must be performed by expert personnel for electrical work or electric piping.
- The power supply terminal and voltage input terminal of the main unit is common. Therefore if additional noise affects the power supply line, incorrect measurements may result.
- Eco-POWER METER is designed to be used in a control panel.
- Do not add an excess power to the display. It might break the inner liquid crystal.

■ As to measurement

- If there is some distortion by harmonic or waveform, it may not measure correctly. Please check with the actual system before adopting it.
- This can't measure the power that flows reverse such as a regenerative electric power. If you measure a reverse power, it shows "0.00kW" and it doesn't count.
- It might not measure an instantaneous current such as an inrush current or an welding machine.
- When measuring the below loads, it might not satisfy with the accuracy guarantee.
 - Out of rating current, Load with low power factor,
 - Load with winding current, Load with ferromagnetic field

■ Static electricity

- Discharge static electricity touching the grounded metal etc. when you touch the unit.
- Excessive static electricity might be generated especially in a dry place.

■ Cleaning

- Wipe dirt of the main unit with soft cloth etc. When thinner is used, the unit might deform or be discolored.

■ Power supply

- Connect a breaker to the voltage input part for safety reasons and to protect the device.
The breaker that connects to the voltage input part must arrange at the position easily reached, and display shows it is the breaker of the equipment.
- Do not turn on the power supply or input until all wiring is completed.

■ Before power on

Please note the following points when turning on power at the first time.

- Confirm there are neither wiring rubbish nor especially an electrical conduction when installed.
- Confirm neither the power supply wiring, the I/O wiring nor the power-supply voltage are wrong.
- Tighten the installation screw and the terminal screw surely.
- Use an electric wire applicable to the rated current.

Chapter 1 Unit's Features and Structure

1.1 Features

■ KW4M Eco-POWER METER is a wattmeter in DIN48 size. Electrical energy (voltage, current, etc.) is measured using AC voltage and AC current input via one of the following systems: single-phase two-wire system, single-phase three-wire system, or three-phase three-wire system.

This also works as an hour meter, that is measured power-on or power-off time, and as a counter that is for pulse output equipment like flowmeter.

■ **Eco-POWER METER is designed chiefly to manage saving energy. It is neither intended nor can it be legally used for billing.**

1.2 Unit's Name and Model Numbers

1.2.1 Main unit

Product name	Terminal type	Protocol	Model No.
KW4M Eco-POWER METER	Screw terminal	MEWTOCOL	AKW5111
		MODBUS (RTU)	AKW5112
	11-pin	MEWTOCOL	AKW5211
		MODBUS (RTU)	AKW5212

Phase and Wire system	<ul style="list-style-type: none"> • Single-phase two-wire • Single-phase three-wire • Three-phase three-wire
Operating power supply (common to measured voltage input)	100-240V AC
Measured current input	50A / 100A / 250A / 400A
Current transformer	Dedicated CT type

1.2.2 Option

Dedicated Current Transformer (CT) Clamp-on type

Product name	Rated primary current	Model No
Dedicated current transformer for 5A/50A	5A / 50A	AKW4801C
Dedicated current transformer for 100A	100A	AKW4802C
Dedicated current transformer for 250A	250A	AKW4803C
Dedicated current transformer for 400A	400A	AKW4804C

Dedicated Current Transformer (CT) Through type

Product name	Rated primary current	Model No
Dedicated current transformer for 50A/100A	50A / 100A	AKW4506C
Dedicated current transformer for 250A/400A	250A / 400A	AKW4507C

Others

Product name	Contents	Model No
Mounting frame	Used for mounting in a panel (supplied with a unit)	AT8-DA4
Rubber gasket	Used for mounting in a panel (supplied with a unit)	ATC18002
Protective cover	Used for protecting a front display (common to Timer/Counter)	AQM4803
DIN rail socket	For 11-pin type(surface mounting)	ATC180041
Rear terminal socket	For 11-pin type (embedded mounting)	AT78051
11P cap	For 11-pin type (connectable directly with soldering)	AT8-DP11
Mounting rail	DIN rail terminal socket fixing rail	AT8-DLA1
Installation frame	Used for mounting	AKW4822
Terminal Protective cover	Used to cover a terminal block (only for screw terminal type)	AKW4823

1.3 Measurement items

Item		Unit	Data displayed range
Instantaneous electric power		kW	0.00 to 9999.99
Integral electrical energy		kWh MWh	0.00 to 9999.99kWh to 10.00MWh to 9999.99MWh 9-digit display: 0.00 to 99999999.99 kWh
Current	L1(CT1)-phase current	A	0.0 to 6000.0
	L2(CT2)-phase current		
Voltage	Voltage between 1-2	V	0.0 to 9999.9
	Voltage between 2-3		
Electricity charge ※	Yen	JPY	0 to 999999
	Dollars	\$	0.0 to 99999.9
	Euros	EUR	0.0 to 99999.9
	Yuan	CNY	0 to 999999
	No currency	CHG	0 to 999999
Corresponding value	Carbon dioxide	kg-CO ₂	0.0 to 999999
Hour meter	ON-time	h(Hour)	0.0 to 99999.9
Pulse input		Count	0 to 999999

※Eco-POWER METER is designed chiefly to manage saving energy.
It is neither intended nor can it be legally used for billing.

Chapter 2 Parts Name and Working

2.1 Parts Names

- ① Mode name display (16-segment)
- ② Lock indicator Light is on when locked.
- ③ Mode indicator Light is on when the mode is being set.
- ④ Output indicator Light is on when pulse is output.
- ⑤ CT direction notification Light is on when CT is connected correctly and current flows.
- ⑥ Display for value selected (7-segment)
Instantaneous electric power,
Integral electrical energy,
Current, Voltage, Electricity charge, Hour meter and Counter
- ⑦ MODE key Use to select mode
- ⑧ SET key Use to set each value entered
- ⑨ Select keys
a) Change which value is displayed.
b) Make settings in a particular mode.

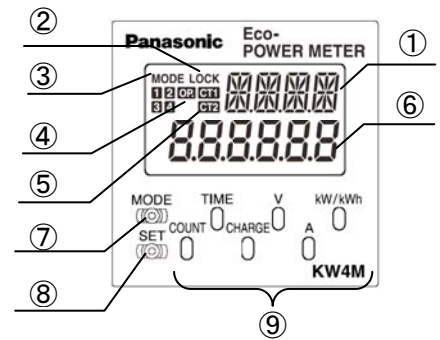

2.2 Keys' Function

	POWER measurement	PULSE measurement
<kW/kWh>	<ul style="list-style-type: none"> Instantaneous electric power → Integral electrical energy (Continuous press) Display by 9-digit (Integral electric power) 	
< A >	L1 (CT1)-phase current → L2 (CT2)-phase current	---
< V >	Voltage between 1 and 2 → Between 2 and 3	---
<CHARGE>	Electricity charge & Corresponding value : JPY → \$ → EUR → CNY → CHG → CO2	---
<TIME>	ON-time → OFF-time	---
<COUNT>	---	<ul style="list-style-type: none"> Count value → Preset value (Continuous press at preset value display) Shift to preset value setting mode
<MODE>+<SET>	Reset (Integral electrical energy, ON-time, OFF-time)	Reset (Count value)
<MODE>	Shift to each setting mode	
<SET>	<ul style="list-style-type: none"> Set each value entered (Continuous press) All keys locked. While in LOCK mode, releases LOCK mode 	

Chapter 3 Wiring

3.1 Terminal arrangement

Functions		Terminal No.	
		Pin type	Screw terminal type
Measured voltage input (Operating power supply)	1, R, R	①	⑧
	2, N, S	②	⑨
	3, T, T	③	⑩
RS-485	(+)	④	⑪
	(-)	⑤	①
Pulse output	(+)	⑥	⑥
	(-)	⑦	⑦
CT input	CT1(k) / IN	⑧	②
	CT1(l), CT2(l)	⑨	③
	CT2(k)	⑩	④
0V		⑪	⑤

- (1) Be sure to wire correctly according to the terminal arrangement and wiring diagrams.
 (2) A DIN rail socket (ATC180041) should be used for Pin type Eco-POWER METER.



The input (applied) voltage to each pin (terminal) is as follows.

Phase and wire	Type	Pin (Terminal)	Input (Applied) voltage
Single-phase two-wire	Pin type	①-②	100-120/200-240VAC (100-120/200-240V~)
	Screw terminal type	⑧-⑨	
Single-phase three-wire	Pin type	①-②-③	100-120VAC (100-120V~ : 3W)
	Screw terminal type	⑧-⑨-⑩	
Three-phase three-wire	Pin type	①-②-③	200-240VAC (200-240V 3~)
	Screw terminal type	⑧-⑨-⑩	

3.2 Power measurement

◇Main unit wiring diagrams

Please connect a breaker (3 to 15A) to the voltage input part for safety reasons and to protect the device. Grounding the secondary side of VT (Voltage transformer) and CT (Current transformer) is not necessary with low-voltage circuit.

◆When measuring load with 100-200V system

Single-phase 2 wire system

*One CT is required to measure.

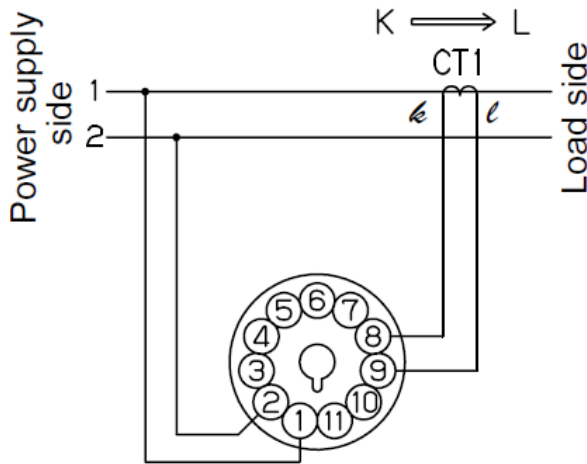

< Pin type >

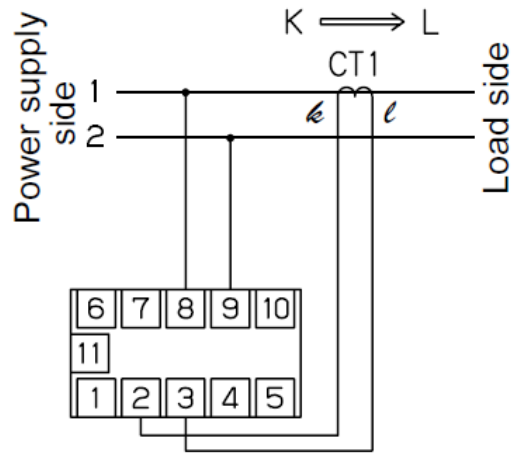

<Screw terminal type>

Single-phase 3 wire system / Three-phase 3 wire system

*Two CTs are required to measure.

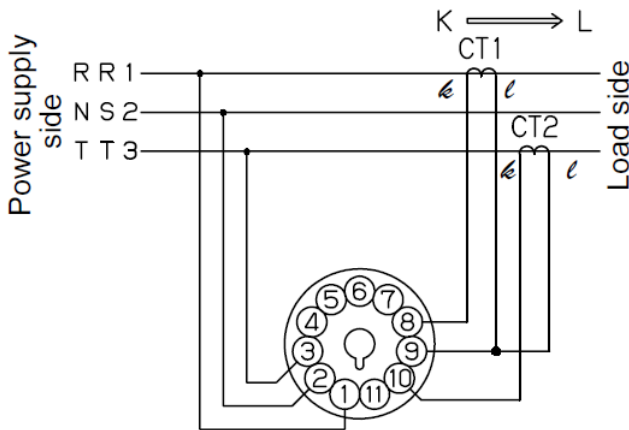

< Pin type >

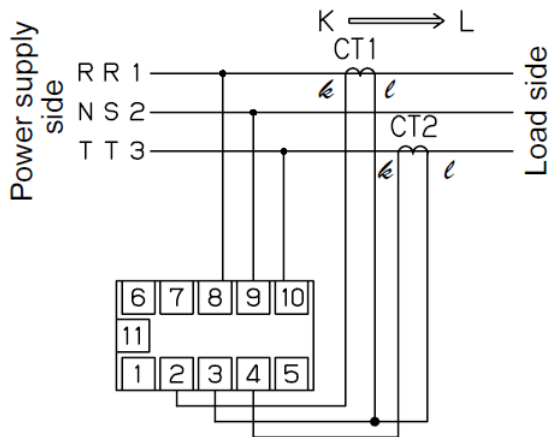

<Screw terminal type>

◆When measuring a load with exceed input voltage.

Voltage transformer (VT) is needed when you measure a load with over rated input voltage (240V).
Use VT, those secondary rating is 110V.

Grounding the secondary side of VT and CT is not necessary with low-voltage circuit.

Single-phase 2 wire system

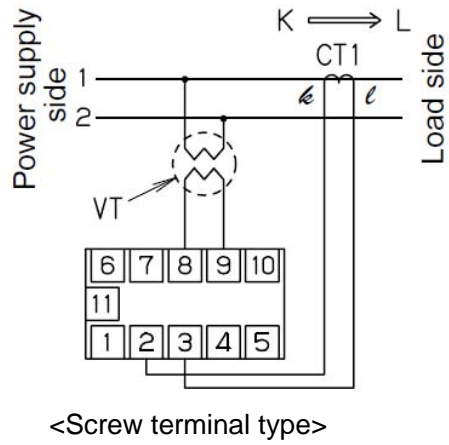
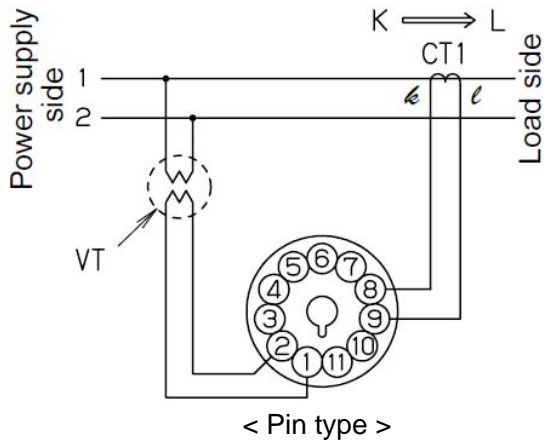

Single-phase 3 wire system / Three-phase 3 wire system

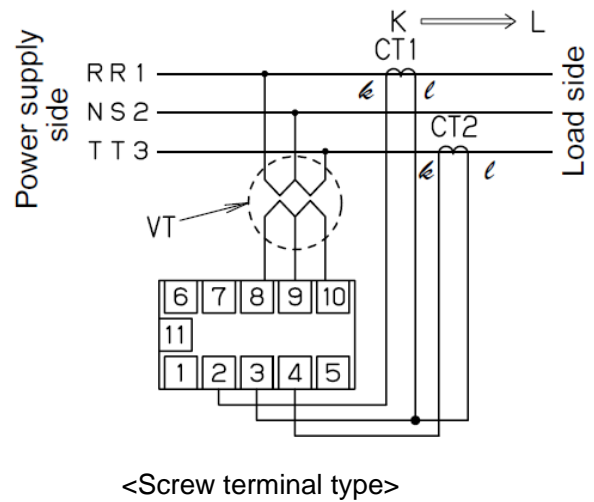
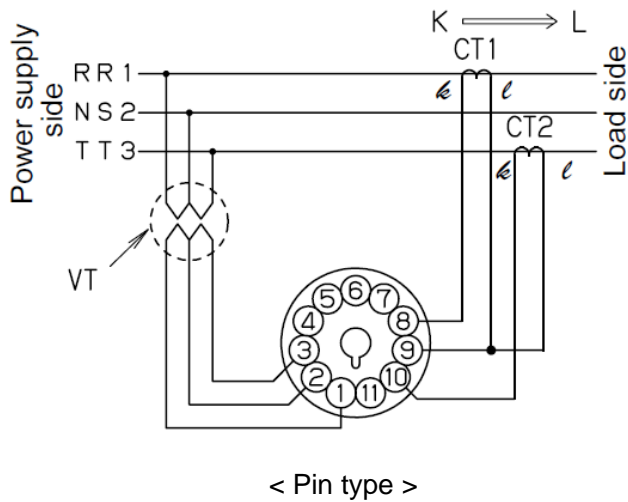

◇How to attach the Current Transformer (CT)

- One current transformer (CT) is needed to measure 1P2W system. Two CTs are needed to measure a 1P3W/3P3W system. Using 2 CTs should be the same.
- Check beforehand that the thickness of the electric wire is smaller than the through-hole of the CT.
- When connecting CT, connect the secondary side to the terminal of the main unit first, and after that wire the primary side to a load electric wire.

Incorrect order might cause an electric shock or break CT.

- The CT has polarity. Wire correctly according to the K and L marks.

Wrong direction can't measure correctly.

- When closing clamp-on type CT, check that there is no foreign materials on the divided face. And make sure it is closed securely once the wire is in place; **if not the measurement value will be not accurate.**
- When CT's cable is extended, it is possible to extend up to about 10m with the cable of AWG#22 or more cross section under the environment without noise at all. Please use the thick cable as much as possible. *Please check beforehand with the actual system in case of extending the cable.
- If there is some distortion by harmonic or waveform, it may not measure correctly. Please check with the actual system before adopting it.
- Separate the wiring (strong electric part) of the measured voltage input terminal (operating power supply terminal) from the CT cable. It may not satisfy the accuracy due to noise.

◇To connect CT with secondary side current 5A

How to connect for measuring by combination with CT (secondary side current 5A)

- (1) Select 5A at CT type setting mode (CT-T).
- (2) Set the primary current of measured CT (secondary side current 5A) at primary side current of CT setting mode (CT-1).
< ex > If the measured CT is 400A/5A, set to "400".
- (3) Clamp the dedicated CT for 5A, which is connected to the main unit first, to secondary side of the CT (secondary side current 5A). CT direction (K→L) should be set for the commercial CT direction.

***Set the CT (secondary side current 5A) and the dedicated CT for 5A approximately 1m apart. If the two CTs are set too close each other, it may not measure accurately due to magnetic field interference.**

(Connection example)

With Ammeter etc.

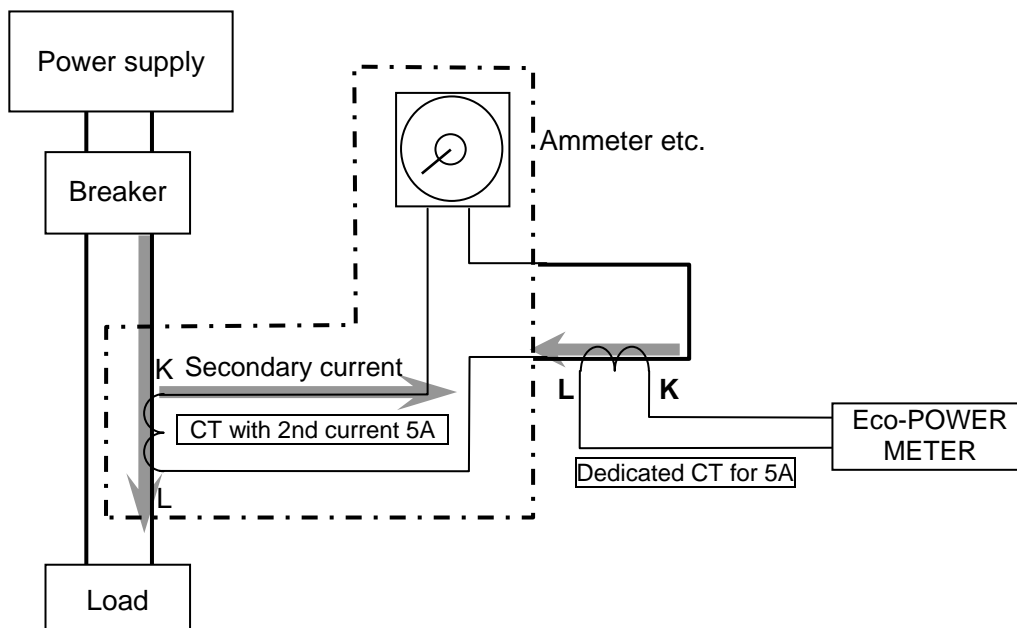

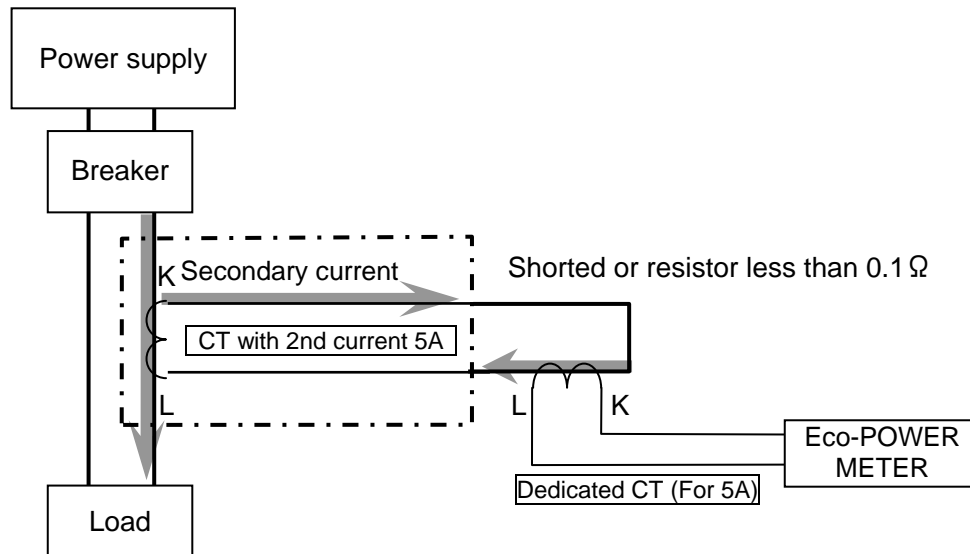
Without Ammeter**3.3 Pulse measurement**

◇ Main unit wiring diagrams

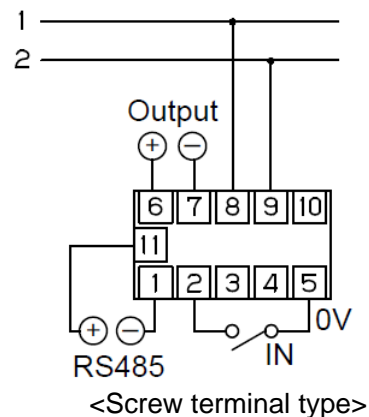
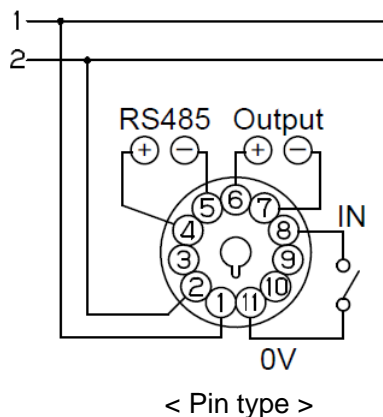

◇ Input connection

• Contact input

Use highly reliable metal plated contacts. Since the contact's bounce time leads directly to error in the count value, use contacts with as short a bounce time as possible. In general, select 30Hz for max. counting speed.

• Non-contact input (Transistor input)

Connect with an open collector. Use the transistor with the following specifications.

$V_{CEO}=20V$ min. $I_C=20mA$ min. $I_{CBO}=6\mu A$ max

Use transistors with a residual voltage of less than 1.5V when the transistor is ON.

* Short-circuit impedance should be less than $1k\Omega$.

(When the impedance is 0Ω , drain current is approx. 5mA.)

The open-circuit impedance should be more than $100k\Omega$.

• Input wiring

Please wire as short as possible by using a shielded wire or a metallic electric wire tube individually. If it is long, it may not work correctly due to floating capacitance of wire.

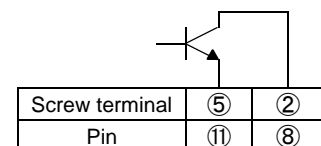
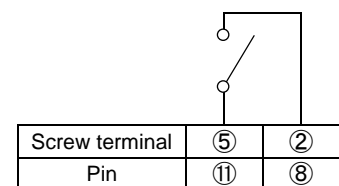

(Note)

Operating power supply input part (measured voltage input) is not insulated to pulse input parts. So the input equipment must have the power supply transformer in which the secondary side is not grounded with the primary and secondary sides insulated, in order to prevent interference of the power supply circuit when connecting the external input circuit. Be sure not to use an auto-transformer.

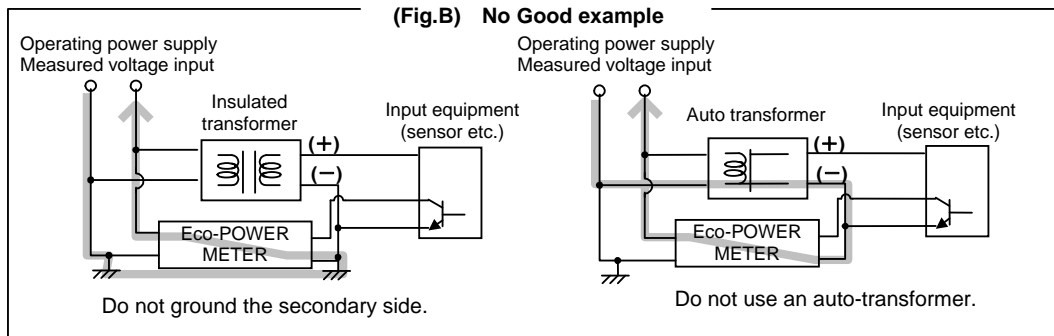
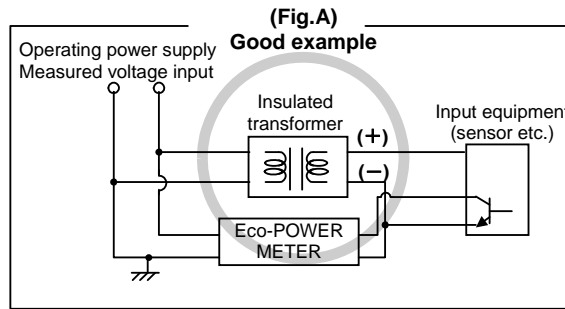

3.4 For Output connection

Since the transistor output is insulated from the internal circuit by a photo-coupler, it can be used both as a NPN output and PNP (equal value) output.

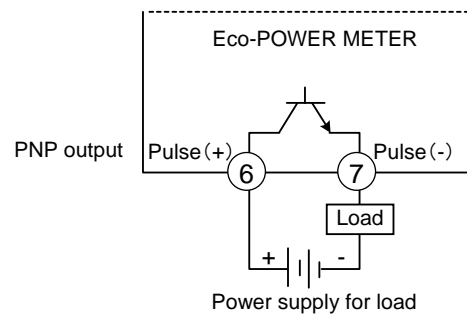
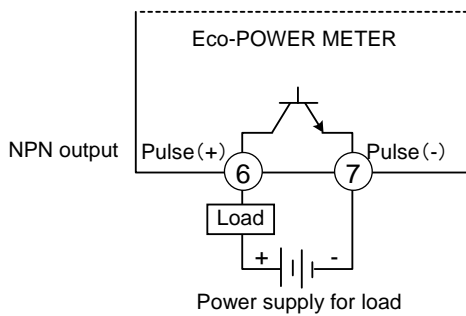

- Wire up to 100m for output connection.
If it is long, it may not work correctly due to floating capacitance of wire.

3.5 For Wiring terminal

- When using a crimp terminal, it should be with insulation sleeve applicable to M3.5 screw as shown below.
- Tightening torque: under 0.8N·m

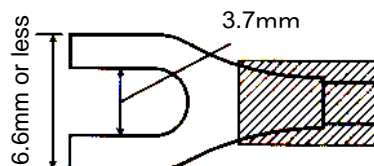

3.6 RS485 communication

- When using shielded cable for the RS485 transmission line, ground one end. Use a class D dedicated earth for grounding. Do not share a ground with other earth lines. (Fig.1)
- Change the slide switch on the side of main unit as a terminal station. (Fig.2)
- Be sure to connect with daisy chain the RS485 transmission line between each unit. Do not use a splitter. (Fig.3)

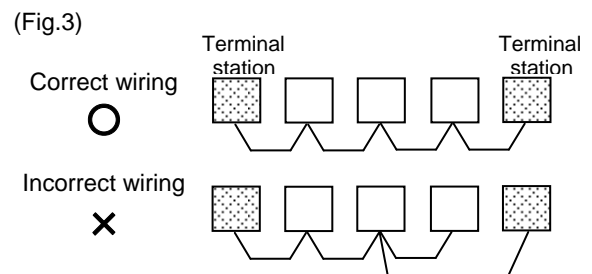
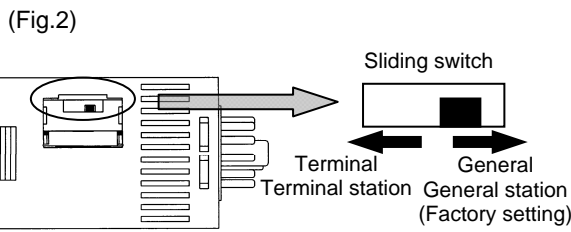
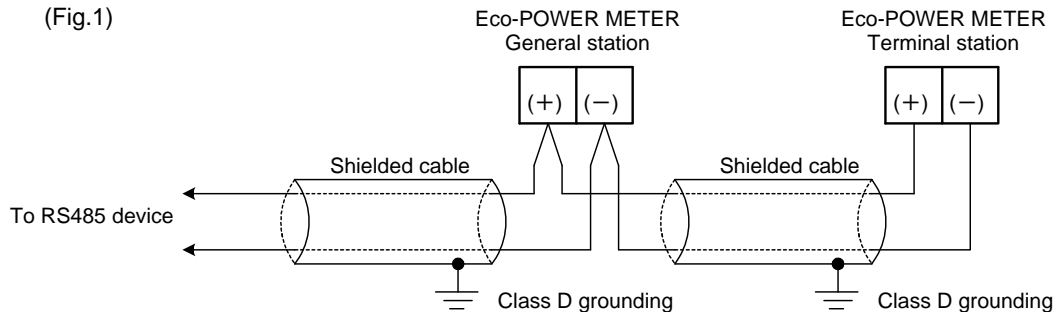

Recommended Cable

Use the transmission cables shown below for Eco-POWER METER RS485 communication system.

Cable	Conductor		Insulator		Cable diameter	Applicable cable
	Size	Resistance (at 20°C)	Material	Thickness		
Twisted-pair with shield	1.25 mm ² (AWG16) or more	Max.16.8 Ω/km	polyethylene	Max. 0.5 mm	Approx. 8.5 mm	HITACHI KPEV-S 1.25 mm ² × 1P Belden Inc. 9860
	0.5 mm ² (AWG20) or more	Max.33.4 Ω/km	polyethylene	Max. 0.5 mm	Approx. 7.8 mm	HITACHI KPEV-S 0.5 mm ² × 1P Belden Inc. 9207
VCTF	0.75 mm ² (AWG18) or more	Max.25.1 Ω/km	PVC	Max. 0.6 mm	Approx. 6.6 mm	VCTF 0.75 mm ² × 2C (JIS)

Cable	Section
Twisted-pair with shield	
VCTF	

Notes

- 1) Use shielded type twist cables.
- 2) Use only one type of the transmission cables.
- 2) Do not mix different types of the cables.
- 3) Use twist pair cables under a bad noise environment.

3.7 Low Voltage Directive

When using in the application confirming to EN61010-1/IEC61010-1, make sure to satisfy the following conditions.

- (1) Pulse output part secure only basic insulation. In order to secure reinforced (double) insulation demanded by EN 61010-1/ IEC61010-1, secure basic insulation or more with load side and reinforced (double) insulation with communication system side.
- (2) Provide the voltage input part with an EN60947-1 or EN60947-3 compliant circuit breaker.
The breaker that connects to the voltage input part must arrange at the position easily reached, and display shows it is the breaker of the equipment.
- (3) Use a wire with basic insulation or more for a wire cramped (or connected) CT.

【Environmental conditions】

- Overvoltage category II, Pollution degree 2
- Indoor use
- An ambient temperature of -10 to 50°C
- An ambient non-condensing humidity of 35 to 85%RH (at 20°C)
- Altitude of 2000m or less

【Mount the product in a place with】

- A minimum of dust, and an absence of corrosive gases
 - No flammable, explosive gasses
 - Few mechanical vibrations or shocks
 - No exposure to direct sunlight
- No large capacity electromagnetic switches or cables through which large current is flowing

Chapter 4 Settings

4.1 Operation procedure

Each setting is classified as follows. There are the detailed explanations from next pages.

•MODE:<MODE>

…Mode for selection of Power measurement (Power meter) or Pulse measurement (Pulse counter).

•MODE1: <MODE>+<kW/kWh> … Mode for setting each parameter for power measurement.

•MODE2: <MODE>+<A> … Mode for setting of each parameter for pulse measurement

•MODE3: <MODE>+<V> … Mode for setting of each parameter for serial communication (RS-485)

•MODE4: <MODE>+<CHARGE> … Mode for setting of each parameter for optional function

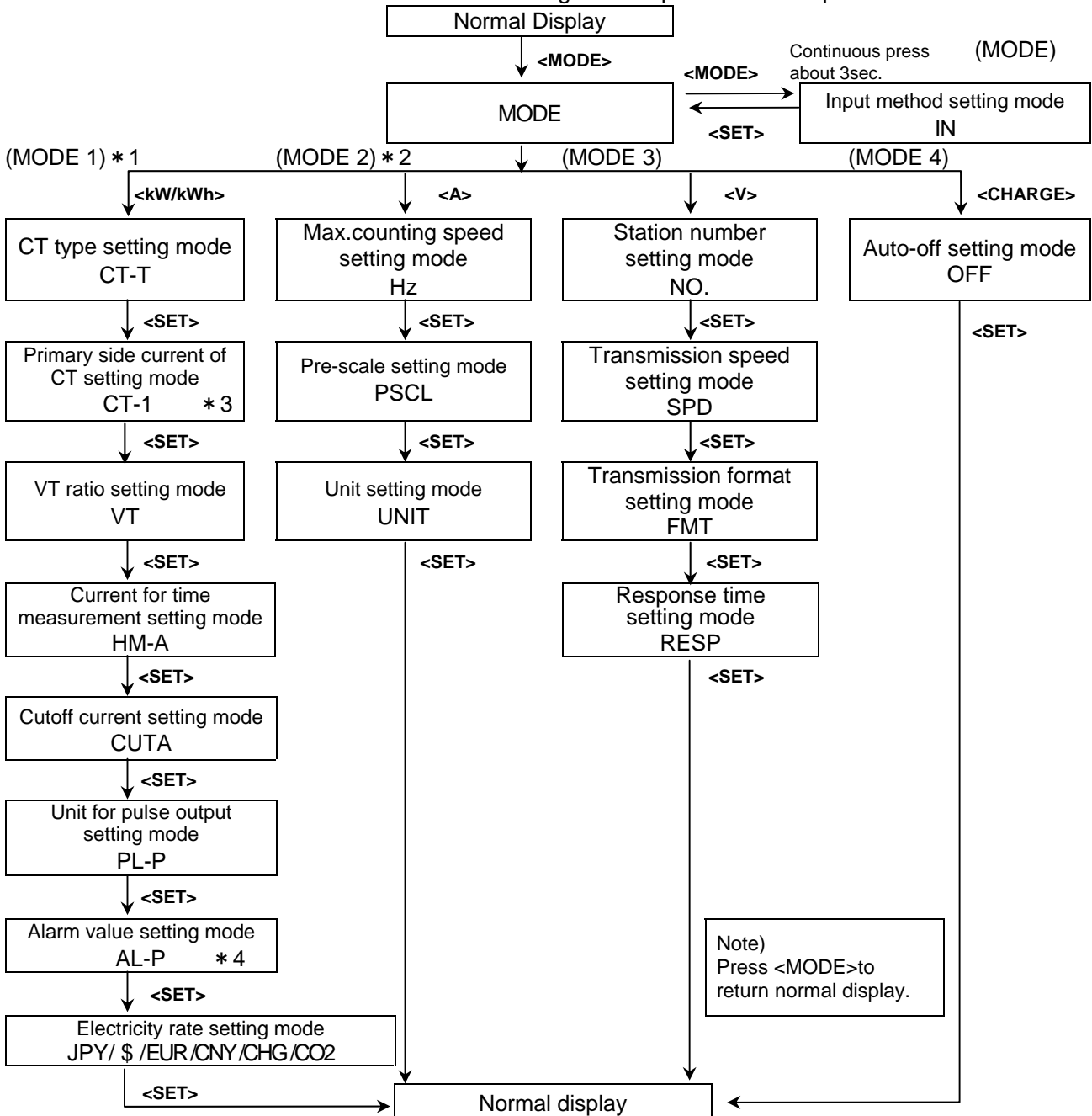

* 1 MODE1 is only for POWER measurement.

* 2 MODE2 is only for PULSE measurement.

* 3 Primary side current of CT setting mode is only for when '5A' is selected on CT type setting mode.

* 4 Alarm value setting mode is only for when 'ALARM' is selected on Unit for pulse output setting mode.

NOTE) Power measurement (Power meter) and Pulse measurement (Pulse counter) can not be used at the same time.

◆ Initial value list

Mode 1		Mode 2	
Item	Initial value	Item	Initial value
CT type	50	Max. counting speed	2000
Primary side current of CT	5		
VT	1.00		
Current for time measurement	1.0	Unit	CNT
Cutoff current	1.0	Mode 3	
Unit for pulse output	0.001	Item	Initial value
Power alarm	9999.99	Station number	1
Electricity rate JPY	10.00	Transmission speed	19200
Electricity rate \$	0.093	Transmission format	8bit-o
Electricity rate EUR	0.085	Response time	5
Electricity rate CNY	10.00	Mode 4	
Electricity rate CHG	10.00	Item	Initial value
CO ₂ Conversion factor	0.410	Auto-off	0

4.2 Setting Mode Explanation

■ The value with underline is initial setting among each setting value. ☆ Set before measurement.

4.2.1 MODE (Select input method)

<MODE>

Input method setting mode **IN**

Mode defines input method, power measurement or pulse measurement.

- Select from POWER / COUNT
- “POWER” is selected when using power measurement (Power meter).
- “COUNT” is selected when using pulse measurement (Pulse counter).

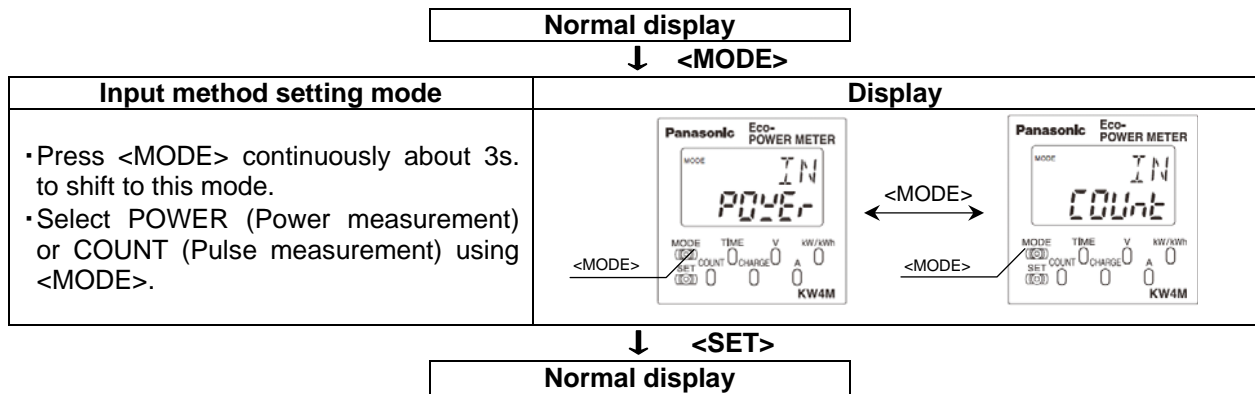

4.2.2 MODE1 (Mode for setting each parameter for power measurement)

This mode doesn't show when pulse measurement is selected.

<MODE>+<kW/kWh>

CT type setting mode **CT-T**

Mode defines input current type of the dedicated CT.

- Select from the type of 5A/50A/100A/250A/400A.
- When the secondary current of CT is 5A, select “5A”.

Primary side current of CT setting mode **CT-1**

*Only when “5A” is selected on CT type setting mode.

Mode defines primary current when measuring by combination with existing CT, its secondary current of 5A.

It is possible to use as the second step for combination with existing CT by selecting “5A” in the CT type setting mode. In this case, it is necessary to set the primary side current.

- It can be set the range of 1 to 4000.
- When connecting 5ACT directly and measure with 5A range, set to “5”.
ex) If measured CT is 400A/5A, set to “400”.

VT ratio setting mode **VT**

Mode defines voltage-input method to the main unit, input voltage directly or uses a voltage transformer (VT) (over 240VAC).

- It can be set the range of 1.00 to 99.99.
“1.00” should be set when voltage input directly without connecting VT.
“1.01 to 99.99” should be set when VT is used to input voltage.
ex) If the VT is 440V/110V, set to “4.00”.

Current for time measurement setting mode HM-A

Mode defines for time measured current. Unit measures ON-time and OFF-time by setting value.

• It can be set the range of 1.0% to 100.0%F.S.

ex) When 10.0 is set, the current exceeds 10.0%F.S is measured as ON-time, the current under 10.0%F.S is measured as OFF-time.

*Measured current is the current of L1(CT1)-phase.

Cutoff current setting mode CUTA

Mode defines load current that does not measured (Cutoff current).

Use to avoid miss-measurement by wiring or induction noise at no-load.

0.00kW is displayed for instantaneous electric power, 0.0A is displayed for current. Integral electrical energy is not measured.

• It can be set the range of 1.0% to 50.0%.

ex) When set to 10.0, current under 10.0%F.S is not measured.

Unit for pulse output setting mode (Power) PL-P

Mode defines unit used for pulse output.

• Select from 0.001/0.01/0.1/1/10/100kWh /Alarm.

When "ALARM" is set, alarm is output at the time when instantaneous electric power is over the setting value.

When one of the "0.001/0.01/0.1/1/10/100"[kWh] is set, one pulse is output at the setting value.

Alarm value setting mode AL-P

* Only when "Alarm" is selected on unit for pulse output setting mode.

Mode defines instantaneous electric power used for alarm output.

• It is set the range of 0.00 to 9999.99kW.

Electricity charge setting mode JPY/\$/EUR/CNY/CHG/CO2

Mode defines electricity charge ratio and conversion factor used as a standard per 1kWh.

The electricity charge ration of 5 kinds of currency (JPY, \$,EUR,CNY,CHG) and CO₂ conversion factor can be set.

• It can be set the range of 0.0 to 99.9 yen/1kWh. (Initial 10.0)

• It can be set the range of 0.000 to 9.999 dollars/1kWh. (Initial 0.093)

• It can be set the range of 0.000 to 9.999 euros/1kWh. (Initial 0.085)

• It can be set the range of 0.00 to 99.99 yuan/1kWh. (Initial 10.00)

• It can be set the range of 0.00 to 99.99 /1kWh. (Initial 10.00)

• CO₂ conversion factor can be set the range of 0.000 to 9.999 kg-CO₂ /1kWh. (Initial 0.410)

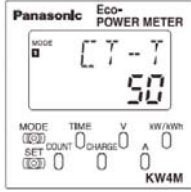
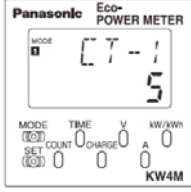
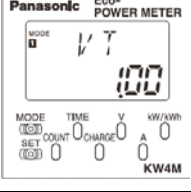
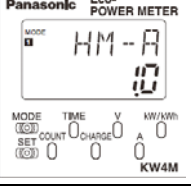
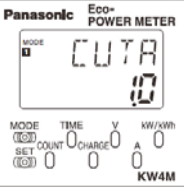
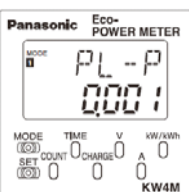
Monitoring display	
↓ <MODE>	
MODE display	
↓ <kW/kWh>	
CT type setting mode	Factory setting / Display
<ul style="list-style-type: none"> • Press <kW/kWh> to change CT type. • CT type is selected from 50→100→250→400→5. 	
↓ <SET>	
Primary side current of CT setting mode	Factory setting / Display
<ul style="list-style-type: none"> • Set primary side current of CT using <kW/kWh>, < A >, < V >. • If measured CT is 100A/5A, set to 100. • If 5A is measured, set to 5. It is only when "5A" is selected on CT type setting mode. 	
↓ <SET>	
VT ratio setting mode	Factory setting / Display
<ul style="list-style-type: none"> • Set VT ratio using <kW/kWh>, < A >, < V >, <CHARGE>. • If the VT is 440/110, set to "4.00". (1.00 to 99.99) 	
↓ <SET>	
Current for time measurement setting mode	Factory setting / Display
<ul style="list-style-type: none"> • Set current for time measurement using <kW/kWh>, < A >, < V >. • If you measure the current over 50.0%F.S, set to "50.0". (1.0 to 100.0) 	
↓ <SET>	
Cutoff current setting mode	Factory setting / Display
<ul style="list-style-type: none"> • Set cutoff current using <kW/kWh>, < A >, < V >. • If you don't measure the current under 10.0%F.S, set to "10.0". (1.0 to 50.0) 	
↓ <SET>	
Unit for pulse output setting mode	Factory setting / Display
<ul style="list-style-type: none"> • Press <kW/kWh> to change unit for pulse output. • Unit is selected from 0.001→0.01→0.1→1→10→100 →ALARM. 	
↓ <SET>	

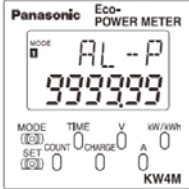
Alarm value setting mode	Factory setting / Display
<ul style="list-style-type: none"> • Set power for alarm using <kW/kWh>,< A >,< V >,<CHARGE>,<TIME>,<COUNT>. *It is only when "ALARM" is selected on unit for pulse output setting mode. (0 to 9999.99kWh) 	 <p>The image shows the display of a Panasonic Eco-POWER METER. The top line shows 'AL-P' and the bottom line shows '999999'. Below the display, there are labels for MODE, TIME, V, and kW/kWh, each with a corresponding button icon and the number '0'. The model number 'KW4M' is printed at the bottom right.</p>

↓ <SET>

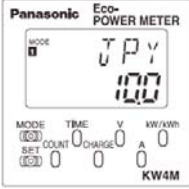
Electricity charge setting mode	Factory setting / Display
<ul style="list-style-type: none"> • Press <COUNT> to change JPY→\$→EUR→CNY→CHG→CO2. • Set the rate per 1kWh using <kW/kWh>,< A >,< V >,<CHARGE>. 	 <p>The image shows the display of a Panasonic Eco-POWER METER. The top line shows 'JPY' and the bottom line shows '100'. Below the display, there are labels for MODE, TIME, V, and kW/kWh, each with a corresponding button icon and the number '0'. The model number 'KW4M' is printed at the bottom right.</p>

↓ <SET>

Monitoring display

4.2.3 MODE2 (Mode for setting each parameter for pulse measurement)

This mode doesn't show when power measurement is selected.

<MODE>+< A >

Max. counting speed setting mode Hz

Mode defines max. counting speed.

- Select from 2kHz/30Hz

Pre-scale setting mode PSCL

Mode defines pre-scale value used for change count value.

- It can be set the range of 0.001 to 100.000. (Initial 1.000)
- The position of decimal point set with this mode is applied to count value and preset value.
ex) When 0.01 (Last 2-digit) is set, the decimal point of count value and preset value has 2 digit under decimal point.

Unit setting mode UNIT

Mode defines unit used for count value display.

- Select from CNT/l/kl/m³.

*Count value does not change even if the unit setting is changed during counting.

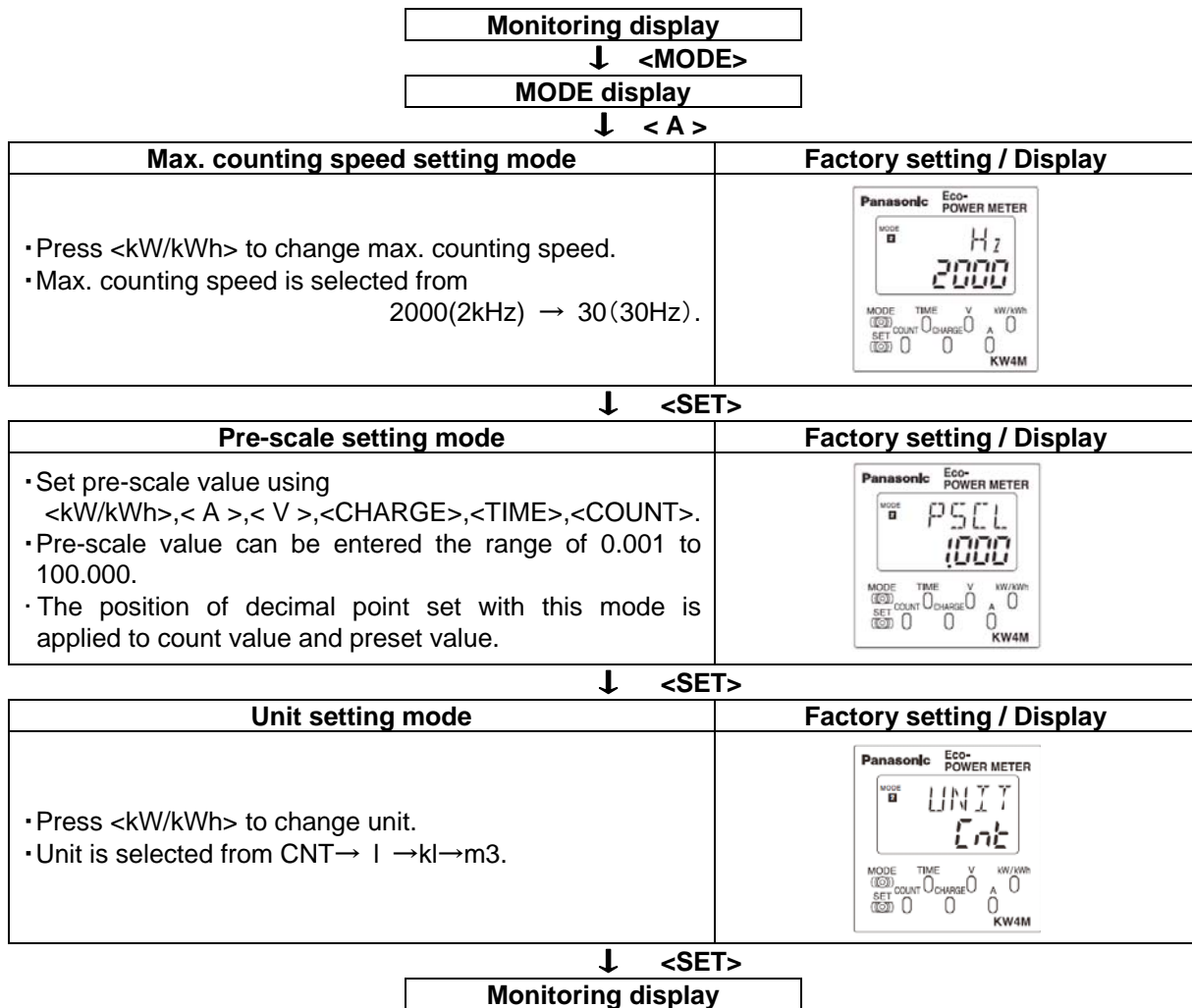

4.2.4 5-2-4 MODE3 (Mode for setting of each parameter for serial communication (RS-485))

<MODE>+< V >

Station number setting mode **NO.**

Mode defines an individual station no. for each unit when two or more units communicate via serial communication (RS-485).

- It can be set the range of 01 to 99.

Transmission speed (Baud rate) setting mode **SPD**

Mode defines serial communication (RS-485) transmission speed. Define the transmission speed according to the master's (PLC etc.).

- Select from 38400/19200/9600/4800/2400[bps].

Transmission format setting mode **FMT**

Mode defines serial communication (RS-485) transmission format (Data length, Parity). Define the transmission format according to the master's (PLC etc.).

- Select from 8bit-o/7bit-n/7bit-E/7bit-o/8bit-n/8bit-E for MEWTOCOL type.

- 8bit-o/8bit-n/8bit-E for MODBUS type.

“n(none)” means parity is not available.

“E(Even)” means parity is even number.

“o(odd)” means parity is odd number.

Response time setting mode **RESP**

MODE defines serial communication (RS485) response time of main unit.

When command is received, it sends response after setting response time passes.

- It can be set the range of 5 to 99ms.

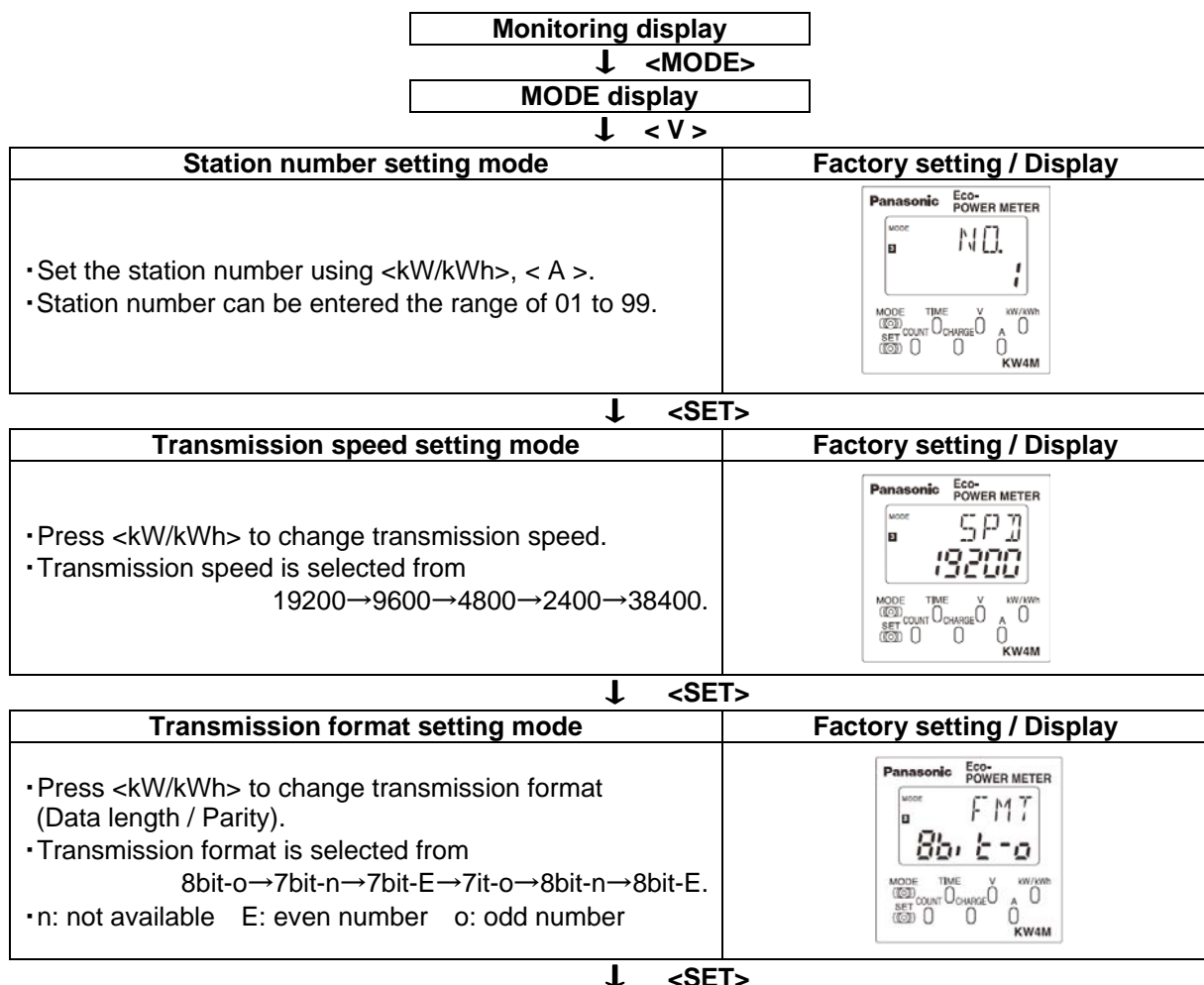

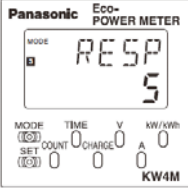
Response time setting mode	Factory setting / Display
<ul style="list-style-type: none"> Set the response time using <kW/kWh>, < A >. Response time can be entered the range of 05 to 99ms. 	

↓ <SET>

Monitoring display

4.2.5 MODE4 (Mode for setting of each parameter for optional function)

<MODE>+<CHARGE>

Auto-off setting mode	OFF
-----------------------	-----

Backlight LED turns off automatically when there is no key operation for a long time.

- Off time can be set the range of 0 to 99min.
- “0” should be set if you want to turn always light on.
- “1~99” should be set if you want to turn light off at setting time.
- After turns off the backlight, any key operation makes it turns on.

Monitoring display

↓ <MODE>

MODE display

↓ <CHARGE>

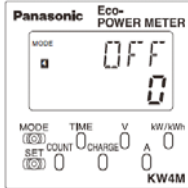
Auto-off setting mode	Factory setting / Display
<ul style="list-style-type: none"> Set auto-off time by minute using <kW/kWh>,< A >. Auto-off time can be entered the range of 0 to 99. “0” should be set to turn always light on. “1~99” should be set to turn light off at setting time (minute). While light off, press any key to light on. 	

↓ <SET>

Monitoring display

Chapter 5 Various Functions

5.1 LOCK mode

It is the mode makes <MODE>key and Select keys unable.

Use when you want to fix one of the measurement displays (For all displays).

When you press <SET>key continuously for about 3sec., the "LOCK" indicator lights and <MODE>key and Select keys become locked (pressing them will have no effect).

Press <SET>key continuously for about 3sec. again to release Lock mode. The "LOCK" indicator goes off and the lock mode is released (unlocked)

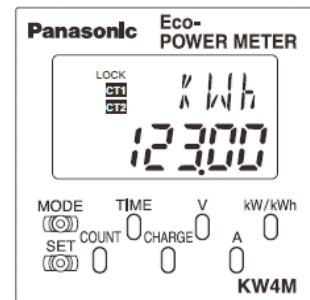

5.2 CT Direction Notification (POWER Measurement)

This shows the connection condition of CT and notices wrong voltage or wrong connection of CT wiring.

- "CT1(CT2)" lights if the input voltage is corresponding to the direction of the current.
- "CT1" lights if the voltage between 1 and 2 is corresponding to the direction of L1-phase current.
- "CT2" lights if the voltage between 2 and 3 is corresponding to the direction of L2-phase current.

*** It does not light if the load current is under the cutoff current (CUTA) or if there is some distortion by harmonic or waveform.**

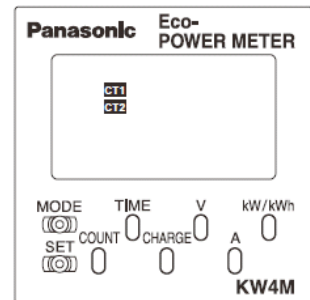

5.3 Counter function (PULSE measurement)

Refer to the mode 1 setting for the way to set.

"OP." is lighting when pulse output.

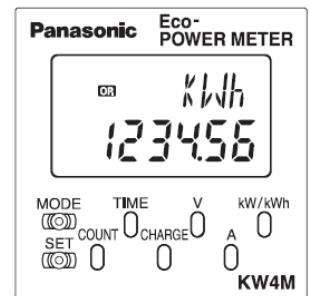

5.3.1 Output depends on integral electric power

Set the unit for pulse output (0.001/0.01/0.1/1/10/100kWh) and pulse output (transistor output) turns on every time when integral electric power reaches the unit. (Pulse width: about 100ms)

5.3.2 Output depends on count value

Set the preset value and pulse output (transistor output) turns on the time when count value reaches the preset value.

Refer to the next in detail.

5.4 Counter function (Pulse measurement)

5.4.1 Operation mode

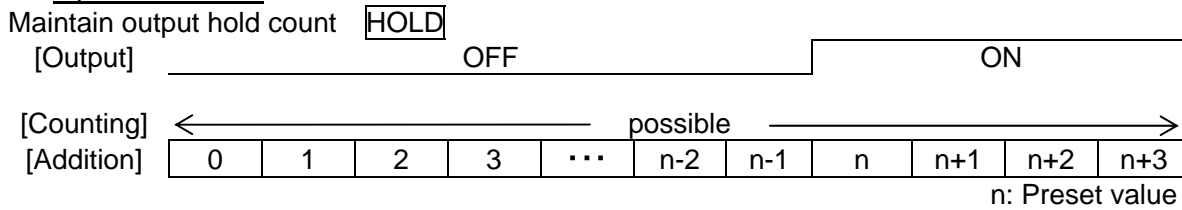

- (1) Output control is maintained after count-up completion and until reset. However counting is possible despite of count-up completion.
- (2) It reverts "0" after counting up full scale, but output control is maintained. However output is OFF if count value or preset value is changed.

5.4.2 Change the Preset Value

It is possible to change the preset value even during counting. However note the following points.

◇When the pre-scale value is "1.000". (PSCL=1.000)

- (1) If the preset value is changed to the value less than the count value, counting will continue until it reaches full scale, returns to "0" and then reaches the new preset value.
- (2) If the preset value is changed to "0", it will not count up at start with "0". It counts up when the counting value comes to "0" again (after reach to full scale). However output is OFF if count value or preset value is changed.
- (3) When the count value is fixed, output is changed according to the changing of preset value as below.
 - ① If the preset value is changed to the value less than the count value or same as count value, output is ON.
(Count value \geq Preset value)
 - ② If the preset value is changed to the value more than the count value, output is OFF.
(Count value $<$ Preset value)

◇When the pre-scale is not "1.000". (PSCL \neq 1.000)

Even if the preset value is changed after counting to full scale, output is not changed.

Chapter 6 Display of each Value

6.1 Instantaneous electric power / Integral Electrical energy

- Press <kW/kWh> to display the instantaneous electric power and integral electrical energy.
- Press <kW/kWh> to change the instantaneous electric power to integral electrical energy.
- *Displayed data is updated at every 1 second.

Instantaneous electric power(kW) → Integral electrical energy(kWh)

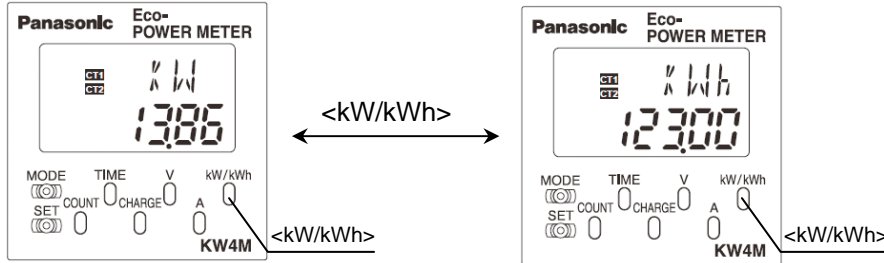

- Integral electrical energy is measured and displayed from 0.00kWh to 9999.99MWh.
- The decimal point and the unit are changed automatically.

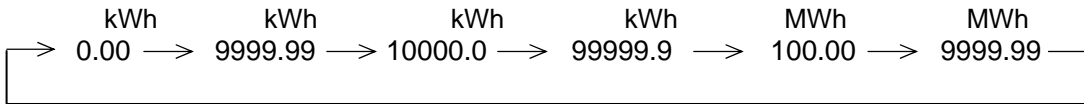

(After reaching the full scale (99999.9kWh), the value reverts to 0.00kWh but continues to measure.)

How to display with 9-digit

Integral electrical energy can be displayed with 9-digit.

- Continuous press <kW/kWh> for about 2sec. or more at the instantaneous electric power or integral electrical energy display, “kWh” shows for about 0.5sec. and integral electrical energy with 9-digit is displayed.

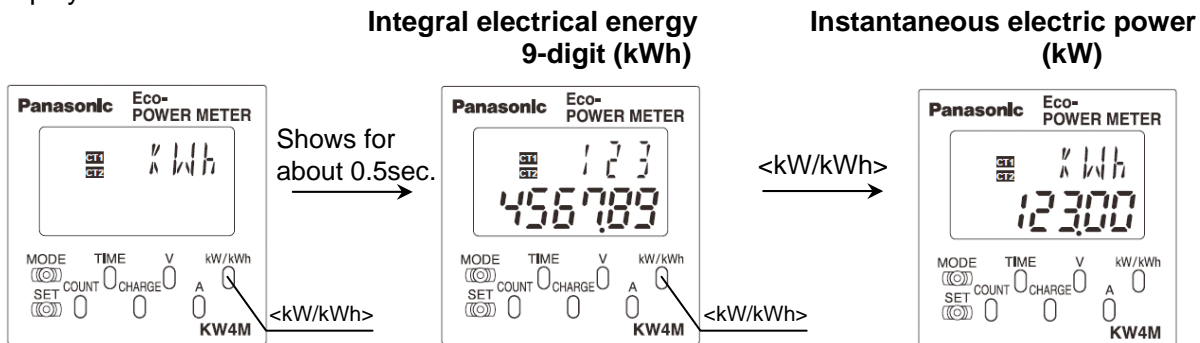

How to reset the integral electrical energy

- Press <MODE> while pressing <SET> makes integral electrical energy clear.

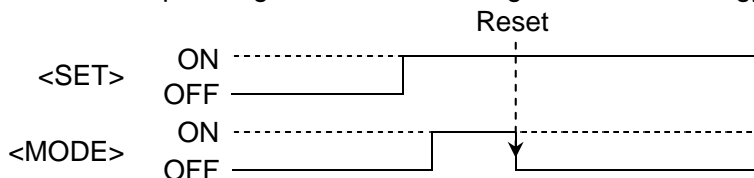

6.2 Current

- Press <A> to display the current value of the load.
- Press <A> to change L1(CT1)-phase current to L2(CT2)-phase current
- *Displayed data is updated at every 1 second.

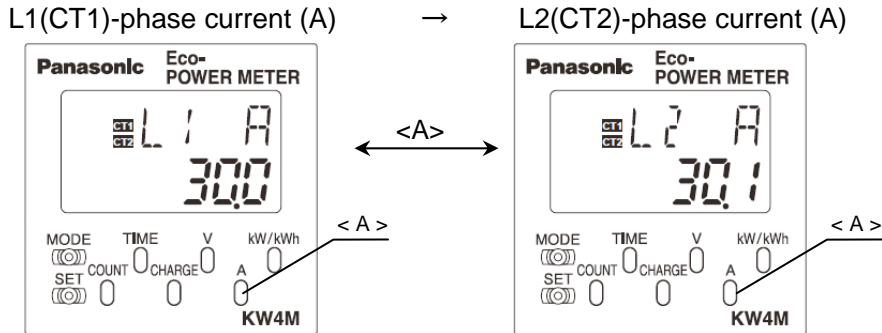

• When input current exceeds 150%F.S. at each range, 「— — — — —」 will be displayed in the lower line.

- Current measurement parts
Eco-POWER METER measures the current as below.

System \ Display	L1(CT1)A	L2(CT2)A
Single-phase two-wire	1(L1)-phase current	-
Single-phase three-wire	1(R)-phase current	3(T)-phase current
Three-phase three-wire	1(R)-phase current	3(T)-phase current

6.3 Voltage

- Press <V> to display the voltage value of the load.
- Press <V> to change voltage between 1 and 2(V) to 2 and 3(V).
- *Displayed data is updated at every 1 second.

Voltage between 1 and 2(V) → Voltage between 2 and 3(V)

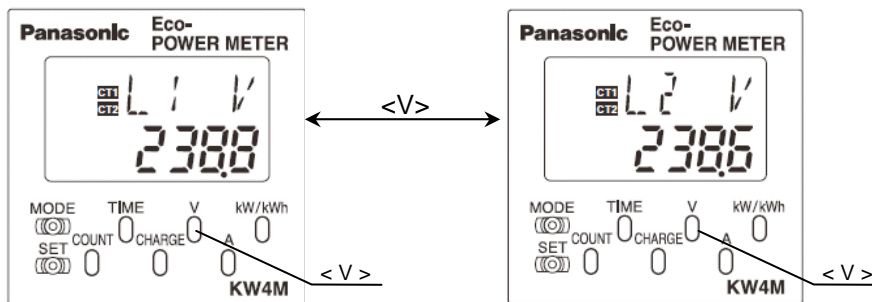

• When input voltage exceeds 150%F.S. at each range, 「— — — — —」 will be displayed in the lower line.

- Voltage measurement parts
Eco-POWER METER measures the voltage as below.

System \ Display	L1V	L2V
Single-phase two-wire	Voltage between 1 and 2 (R-phase)	—
Single-phase three-wire	Voltage between 1 and 2 (R-phase)	Voltage between 2 and 3 (T-phase)
Three-phase three-wire	Voltage between 1 and 2 (Between R and S line)	Voltage between 2 and 3 (Between S and T line)

6.4 Electricity Charge

It displays the standard electricity charge or corresponding value for the integral electrical energy.

- Press <CHARGE> to display the electricity charge and corresponding value.
- At electricity charge display, press <CHARGE> to change between JPY, \$, EUR, CNY, CHG and CO2.

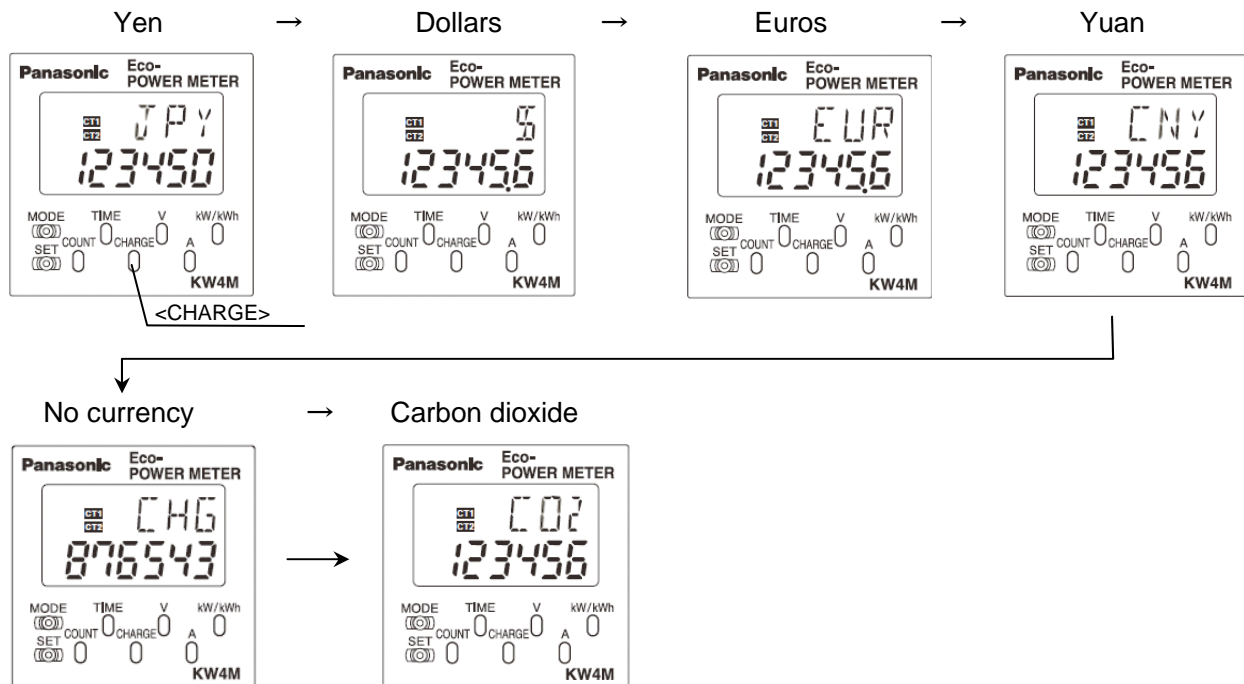

6.5 Hour Meter

- Press <TIME> to display the load ON-time or load OFF-time measured by CT1.
- Press <TIME> to change the load ON-time to load OFF-time.

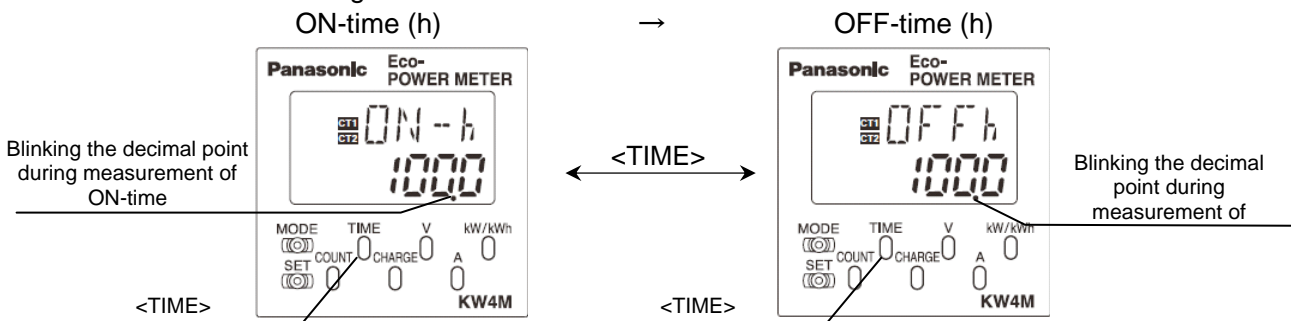

* When load current is under the setting current for time measurement(HM-A), it measures as OFF-time. When load current is exceeded to the setting current for time measurement(HM-A), it measures as ON-time. Current for time measurement (HM-A) is set to under cutoff current (CUTA), all current is measured as OFF-time.

* Current flow of CT1

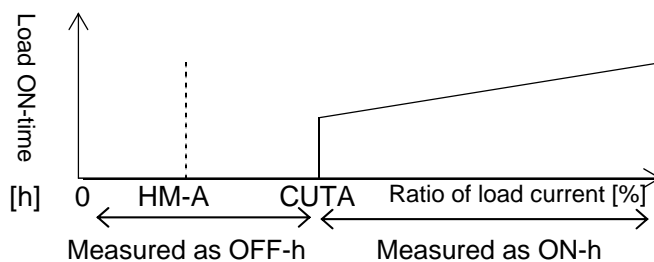

* After reaching the full scale (99999.9h), the value reverts to 0.0h but continues to measure.

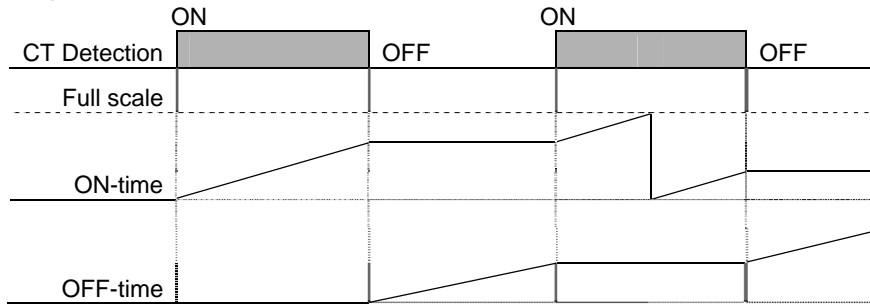

How to Reset ON/OFF-time

• Press <MODE> while pressing <SET>key makes ON / OFF-time clear.

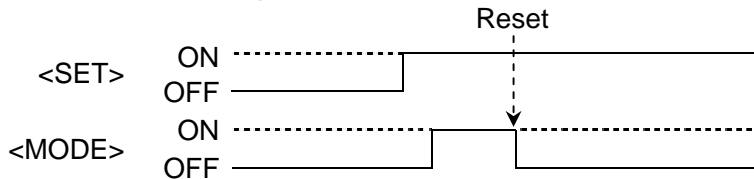

6.6 Count Value / Preset Value

It displays present count value (pulse input value) and preset value.

- Press <COUNT> to display count value (pulse input value).
- Press <COUNT> to change count value to preset value.

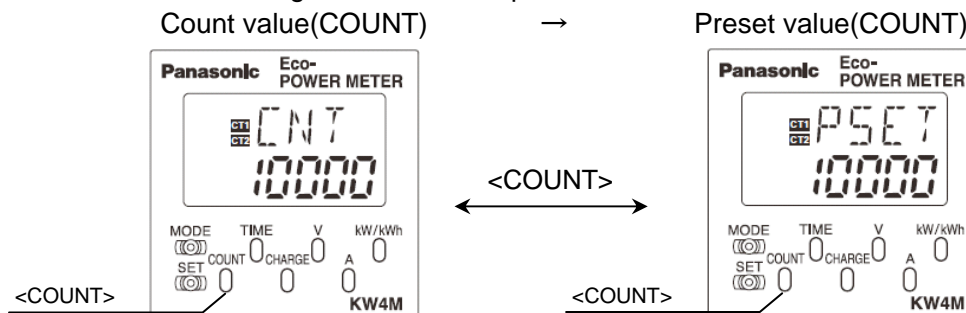

How to Enter the Preset Value

- Press <COUNT> continuously for about 3sec. at preset value display, "PSET" is blinking.
- Enter a preset value using <kW/kWh>, < A >, < V >, <CHARGE>, <TIME> and <COUNT>.
- Press <SET> to set the entered value. "PSET" stops blinking.

Position of Decimal Point

• The position of decimal point for count value and preset value is decided according to the setting at 'Pre-scale setting mode'.

Ex) When preset value set to 0.01, the decimal point is fixed the last 2 digit for count value and preset value.

How to Reset Count value

• Press <MODE> while pressing <SET>key makes count value clear.

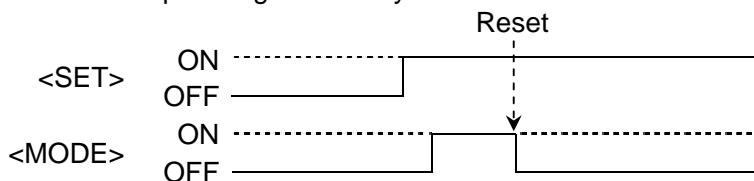

Chapter 7 Communications

7.1 Communication Procedures

Communication starts with command transmission from the host computer (hereafter Master) and ends with the response of Eco-POWER METER (hereafter Slave).

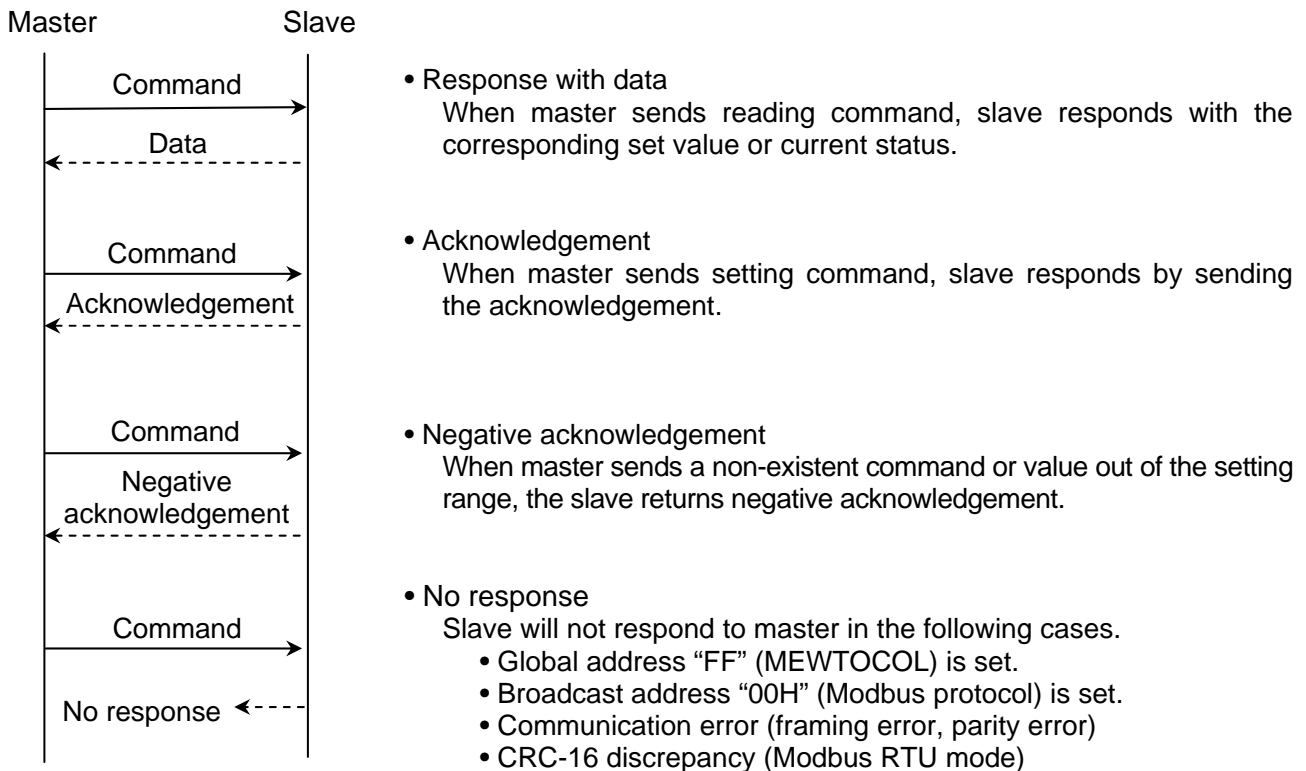

7.2 Communication timing

- ◆ The minimum access time from the master is 1 sec. (Minimum time for update the data)
Eco-POWER METER may not response due to noise and so on, be sure to check that it receives the response from Eco-POWER METER.
- ◆ In order to improve the communication quality, we recommend to send the transmission again.

Communication timing of RS-485

◇Eco-POWER METER (Slave) side

When Eco-POWER METER (Slave) starts transmission to RS-485 communication line, it is arranged so as to provide an idle status transmission period of about 5 to 99ms (setting available) before sending the response to ensure the synchronization on the receiving side.

And after sending the response, transmitter is cut within transmission period of about 20ms.

◇Master side (Cautions of setting a program)

At communication, keep the following conditions.

- 1) Set the program so that the master can disconnect the transmitter from the communication line within the transmission period of about 3ms after sending the command in preparation for reception of the response from Eco-POWER METER (Slave).
- 2) To avoid collision of transmissions between the master and Eco-POWER METER (Slave), send a next command after checking that the master received the response.

7.3 MEWTOCOL communication

7.3.1 Overview of MEWTOCOL-COM (RS-485)

◆Command and response functions

The computer sends commands (instructions) to Eco-POWER METER, and receives responses in return. This enables the computer and Eco-POWER METER to converse with each other, so that various kinds of information can be obtained and provided.

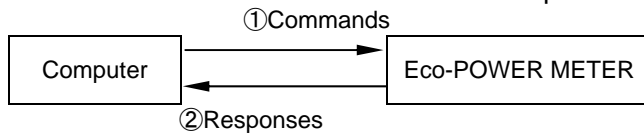

◆Command and response formats

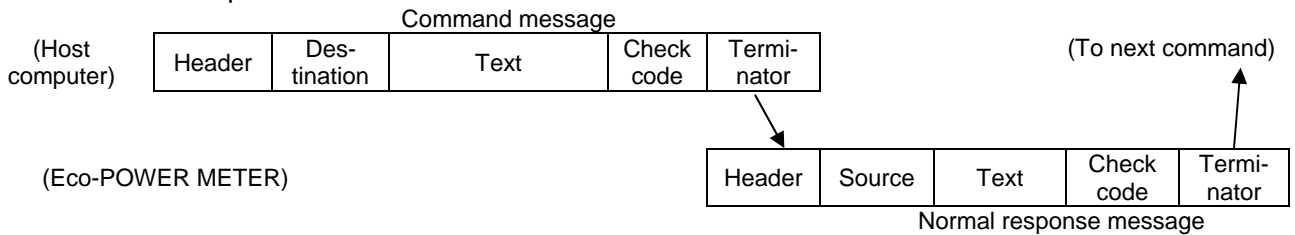

◇Control codes

Name	Character	ASCII code	Explanation
Header	%	25H	Indicates the beginning of a message.
Command	#	23H	Indicates that the data comprises a command message.
Normal response	\$	24H	Indicates that the data comprises a normal response message.
Error response	!	21H	Indicates that the data comprises a response message when an error occurs.
Terminator	CR	0DH	Indicates the end of a message.

◇Destination and source AD (H), (L)

Two-digit decimal 01 to 99 (ASCII codes)

Command messages contain a station number for Eco-POWER METER that receives the message. When FF (ASCII code table) is used, however, the transmission is a global transmission (sent to all stations at once).

Note) When a global transmission is sent, no response to the command message is returned.

◇Block check code Bcc (H), (L)

Two-digit hexadecimal 00 to FF (ASCII codes)

These are codes (horizontal parity) that are used to detect errors in the transmitted data.

If “**” is entered instead of “Bcc”, however, messages can be transmitted without the Bcc. In this case, the Bcc is included with the response

◇Error code Err (H), (L)

Two-digit hexadecimal 00 to FF (ASCII codes)

These indicate the content if an error occurs.

◆Bcc (Block Check Code)

-The Bcc is a code that carries out an error check using horizontal parity, to improve the reliability of the data being sent.

-The Bcc uses an exclusive OR from the header (%) to the final character of the text, and converts the 8-bit data into a 2-character ASCII code.

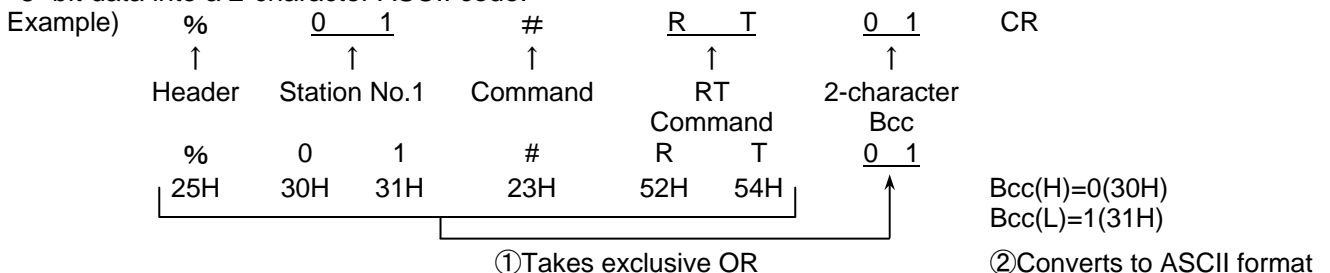

7.3.2 Data Register List

Data register	Name	Unit	Kind of data	Range	R/W
DT00050	Rate ¥ (JPY)	0.1¥	Unsigned 16bit	0 to 99.9	R/W
DT00051	Rate \$	0.001\$	Unsigned 16bit	0.000 to 9.999	R/W
DT00052	Rate €(EUR)	0.001€	Unsigned 16bit	0.000 to 9.999	R/W
DT00053	Rate yuan (CNY)	0.01 yuan	Unsigned 16bit	0.00 to 99.99	R/W
DT00054	Rate No currency (CHG)	0.01	Unsigned 16bit	0.00 to 99.99	R/W
DT00055	Conversion factor (CO ₂)	0.001 kg-CO ₂	Unsigned 16bit	0.000 to 9.999	R/W
DT00100	Integral electric power	0.01kWh	Unsigned 32bit	0 to 9999999.99	R/W
DT00101					
DT00107	L1(CT1)-phase current	0.1A	Unsigned 16bit	0.0 to 999.9	R
DT00109	L2(CT2)-phase current	0.1A	Unsigned 16bit	0.0 to 999.9	R
DT00060	CT type	Rated A (rms)	Unsigned 16bit	5,50,100,250,400	R/W
DT00061	Unit for Pulse output	—	Unsigned 32bit	1(0.001),10(0.01),100(0.1),1000(1),10000(10),100000(100)999(Instantaneous electrical energy: Values of DT00064 and 00065 are applied)	R/W
DT00062					
DT00063	Primary side current value when CT 5A	A	Unsigned 16bit	1 to 4000	R/W
DT00064	Alarm value (Instantaneous electric power)	0.01kW	Unsigned 32bit	0 to 9999.99	R/W
DT00065					
DT00066	VT ratio	0.01	Unsigned 16bit	1.00 to 99.99	R/W
DT00067	Threshold value current for time measurement	0.1%	Unsigned 16bit	1.0 to 100.0	R/W
DT00068	Cutoff current	0.1%	Unsigned 16bit	1.0 to 50.0	R/W
DT00150	Load ON-time	0.1h	Unsigned 32bit	0 to 99999.9	R/W
DT00151					
DT00152	Load OFF-time	0.1h	Unsigned 32bit	0 to 99999.9	R/W
DT00153					
DT00154	Pulse count value	—	Unsigned 32bit	0 to 999999	R/W
DT00155					
DT00158	Preset value	—	Unsigned 32bit	0 to 999999	R/W
DT00159					
DT00160	Pre-scale value	0.001	Unsigned 32bit	1 to 100000 (0.001 to 100.000) * Decimal point fixed	R/W
DT00161					
DT00162	Max.counting speed	Hz	Unsigned 16bit	30 or 2000	R/W
DT00163	Auto-off time	min	Unsigned 16bit	0 to 99(0 means always light on)	R/W
DT00164	Display unit	—	Unsigned 16bit	0:CNT, 1: l, 2: kl, 3: m3	R/W
DT00170	Voltage between 1 and 2	0.1V	Unsigned 32bit	0 to 9999.9	R
DT00171					
DT00172	Voltage between 2 and 3	0.1V	Unsigned 32bit	0 to 9999.9	R
DT00173					
DT00176	Instantaneous electric power	0.01kW	Unsigned 32bit	0 to 9999.99	R
DT00177					

Note1) R: Read W: Write

2) Data register except specified is 0.

3) DT00061,00062 (Unit for pulse output) and DT00160,00161 (Pre-scale value) is numerical value (in the range of data register).

- 4) If each setting value is written by communication, it is written to internal EEPROM at the same time. Therefore, changing settings frequently shortens the life of EEPROM. Avoid usage like this.
- 5) Write data within the range when you write it.

7.3.3 Error Codes

◇ Basic procedure errors

Error code	Error name	Explanation
40H	Bcc error	• A Bcc error occurred in the command data.
41H	Format error	• A command message was sent that does not fit the transmission format.
42H	No support error	• A command was sent that is not supported.
43H	Procedure error	• Delimiter with multiple frames was sent. • The response shall be multiple frames.

◇ Application error

Error code	Error name	Explanation
60H	Parameter error	• The data code is not "D".
61H	Data error	• Word No. was specified without decimal. (0000F etc.) • The starting word No. is bigger than the ending word No. • Writing data has a code that is not hexadecimal.
62H	Registration error	• Too many registrations have been entered (more than 17). • "MD" command was sent when some registration has been exist. • "MG" command was sent when registration has not been entered.

◇ Self-diagnostic error

Error code	Error name	Explanation
45H	Operation error	• At "WD" command, writing data is exceeded the range of data register.

7.3.4 Command

Eco-POWER METER has 5 kinds of commands.

Command name	Code	Explanation
Read data area	RD	Reads the contents of data area.
Write data to data area	WD	Writes data to a data area.
Register or Reset data monitored	MD	Registers the data to be monitored.
Monitoring start	MG	Monitors a registered data.
Read status	RT	Reads the specifications of Eco-POWER METER and error code if an error occurs.

◆[RD]: Read data area (Reads the contents of data area.)

◇Command

%	Destination x10 ¹ x10 ⁰	#	R	D	D	Starting word No. 5 characters x10 ⁴ x10 ³ x10 ² x10 ¹ x10 ⁰					Ending word No. 5 characters x10 ⁴ x10 ³ x10 ² x10 ¹ x10 ⁰					Bcc x16 ¹ x16 ⁰	CR
---	--	---	---	---	---	---	--	--	--	--	---	--	--	--	--	--	----

◇Normal response (Read successful)

%	Source x10 ¹ x10 ⁰	\$	R	D	First register contents 4 characters x16 ¹ x16 ⁰ x16 ³ x16 ²				Last register contents 4 characters x16 ¹ x16 ⁰ x16 ³ x16 ²				Bcc x16 ¹ x16 ⁰	CR
					(lower word) (higher word)				(lower word) (higher word)					

◇Error response

%	Source x10 ¹ x10 ⁰	!	Error code x16 ¹ x16 ⁰		Bcc x16 ¹ x16 ⁰		CR
(Common to each command)							

◆[WD]: Write data area (Writes data to a data area.)

◇Command

%	Destination x10 ¹ x10 ⁰	#	W	D	D	Starting word No. 5 characters x10 ⁴ x10 ³ x10 ² x10 ¹ x10 ⁰					Ending word No. 5 characters x10 ⁴ x10 ³ x10 ² x10 ¹ x10 ⁰					First writing data 4 characters x16 ¹ x16 ⁰ x16 ³ x16 ²				⇒
																(lower word) (higher word)				

◇Normal response (Write successful)

%	Source x10 ¹ x10 ⁰	\$	W	D	Bcc x16 ¹ x16 ⁰		CR							
								⇒ Last writing data 4 characters x16 ¹ x16 ⁰ x16 ³ x16 ²				Bcc x16 ¹ x16 ⁰		CR
								(lower word) (higher word)						

◆[MD]: Register or Reset data monitored (Registers the data to be monitored.) *Up to 16 points can be registered for one unit.

◇Command (Register)

%	Destination x10 ¹ x10 ⁰	#	M	D	D	Word No. 5 characters x10 ⁴ x10 ³ x10 ² x10 ¹ x10 ⁰					D	Word No. 5 characters x10 ⁴ x10 ³ x10 ² x10 ¹ x10 ⁰					Bcc x16 ¹ x16 ⁰	CR							
																Data specification ①					Data specification ②				

◇Command (Register reset)

%	Destination x10 ¹ x10 ⁰	#	M	D	F	F	F	F	F	F	Bcc x16 ¹ x16 ⁰		CR		
														16 points max.	

◇Normal response (Registration successful)

%	Source x10 ¹ x10 ⁰	\$	M	D	BCC x16 ¹ x16 ⁰		CR
Fixed (6 characters)							

◆[MG]: Monitoring start (Monitors a registered data.)

◇Command

%	Destination x10 ¹ x10 ⁰	#	M	G	Bcc x16 ¹ x16 ⁰		CR
---	--	---	---	---	--	--	----

◇Normal response (Monitoring successful)

%	Source x10 ¹ x10 ⁰	\$	M	G	0	0	0	No. of characters in data line 2 characters x16 ¹ x16 ⁰	Data ① 4 characters x16 ¹ x16 ⁰ x16 ³ x16 ²				Data ② 4 characters x16 ¹ x16 ⁰ x16 ³ x16 ²				Bcc x16 ¹ x16 ⁰	CR
									(lower word) (higher word)				(lower word) (higher word)					

◆[RT]: Read the status of Eco-POWER METER (Reads the specifications of Eco-POWER METER and error codes if an error occurs.)

◇Command

%	Destination x10 ¹ x10 ⁰	#	R	T	Bcc x16 ¹ x16 ⁰		CR
---	--	---	---	---	--	--	----

Operation mode
01: On operating
00: Stop

Error flag
01: abnormal
00: normal

◇Normal response (Read successful)

%	Source x10 ¹ x10 ⁰	\$	R	T	Model code 1 2 characters x16 ¹ x16 ⁰		Model code 2 2 characters x16 ¹ x16 ⁰		Version 4 characters x16 ³ x16 ² x16 ¹ x16 ⁰				Operation mode 2 characters x16 ¹ x16 ⁰		Error flag 2 characters x16 ¹ x16 ⁰		Self-diagnostic error No. 4 characters x16 ¹ x16 ⁰ x16 ³ x16 ²				Bcc x16 ¹ x16 ⁰	CR
																(lower word) (higher word)						

Model code 1: 99 Model code 2: 11

7.4 MODBUS (RTU) Communication

7.4.1 Overview of MODBUS (RTU)

◆8-bit binary data in command is transmitted as it is.

Data format	Start bit	: 1 bit
	Data bit	: 8 bits * 7bits is not available.
	Parity	: No parity, Even parity, Odd parity Selectable
	Stop bit	: 1 bit (Fixed)
	Error detection	: CRC-16 (Cyclic Redundancy Check)
	Data interval	: 3.5 character transmission time or more

◆Message configuration

RTU mode is configured to start after idle time processing of more than 3.5 character transmissions and end after idle time processing of more than 3.5 character transmissions.

3.5 idle characters	Slave address	Function code	Data	Error check CRC-16	3.5 idle characters
	8-bit	8-bit	* * bits	16-bit	

Master judges the transmission complete after no command for 4-characters idle time and process the command.

*Transmission speed and judgment time to complete transmission

Transmission speed (bps)	Judgment time to complete (ms)
38400	about 1.00
19200	about 2.00
9600	about 4.00
4800	about 8.00
2400	about 16.00

◇Slave address:

Slave address is an individual instrument number on the slave side and is set within the range 1 to 99 (01H to 63H). Master identifies slaves by the slave address of the requested message.

Slave informs master which slave is responding to master by placing its own address in the response message. Slave address 0 (00H, broadcast address) can identify all slaves connected. However slaves do not respond.

◇Function code: Function code is command code for the slave to undertake the following action types.

Function code	Contents
03(03H)	DT Read
06(06H)	DT1 word write
16(10H)	DT several data write

Function code is used to discern whether the response is normal (acknowledgement) or if any error (negative acknowledgement) has occurred when slave returns response message to master.

When acknowledgement is returned, slave simply returns original function code. When negative acknowledgement is returned, MSB of original function code is set as 1 for response.

For example, when the master sends request message setting 00H to function code by mistake, slave returns 80H by setting MSB to 1, because the former is an illegal function.

For negative acknowledgement, the exception codes below are set to data of response message and returned to master in order to inform it of what kind of error has occurred.

Exception code	Contents
1(01H)	Illegal Function (Non-existent function)
3(03H)	Illegal data value (Value out of the device numbers)

note1) Even if it commands to write (06H.10H) to non-existent data address, slave response with acknowledgement. However, it doesn't write.

note2) Even if it commands to write the value out of the setting range, slave response with acknowledgement. However, it doesn't write.

note3) The maximum number of reading slaves is 26 (57 bytes), the maximum number of writing slaves is 23 (55 bytes).

◇Data: Data depends on the function code.

A request message from the master side is composed of data item, number of data and setting data.

A response message from the slave side is composed of number of bytes, data and exception code in negative acknowledgement.

◇Error check: 16-bit data to detect communication errors. Refer to the next.

◇Acknowledgement response

When command is to write 1 point, same message of command is responded.

When command is to write several points, part of command message (6 bytes) is responded.

◆Error check

After calculating CRC-16 (Cyclic Redundancy Check) from slave address to the end of data, the calculated 16-bit data is appended to the end of message in sequence from low order to high order.

<How to calculate CRC>

In CRC system, the information is divided by the polynomial series. The remainder is added to the end of the information and transmitted. The generation of polynomial series is as follows.

(Generation of polynomial series: $X^{16} + X^{15} + X^2 + 1$)

- 1) Initialize the CRC-16 data (assumed as X) (FFFFH).
- 2) Calculate exclusive OR (XOR) with the 1st data and X. This is assumed as X.
- 3) Shift X one bit to the right. This is assumed as X.
- 4) When a carry is generated as a result of the shift, XOR is calculated by X of 3) and the fixed value (A001H). This is assumed as X. If a carry is not generated, go to step 5).
- 5) Repeat steps 3) and 4) until shifting 8 times.
- 6) XOR is calculated with the next data and X. This is assumed as X.
- 7) Repeat steps 3) to 5).
- 8) Repeat steps 3) to 5) up to the last data.
- 9) Set X as CRC-16 to the end of message in sequence from low order to high order.

◆Message example

<1> Reading electricity rate (0032H) of address 1

•Command

3.5 idle characters	Slave address (01H)	Function code (03H)	Data item (0032H)	Number of data (0001H)	Error check CRC-16 (25C5H)	3.5 idle characters
	1	1	2	2	2	←character number

•Response message from slave in normal status (When Rate=1000(10.00) [03E8H])

3.5 idle characters	Slave address (01H)	Function code (03H)	Number of response byte (02H)	Number of data (03E8H)	Error check CRC-16 (B8FAH)	3.5 idle characters
	1	1	1	2	2	←character number

<2> Setting electricity rate (0032H) of address 1 (When rate is set to 20.00(2000) [07D0H])

•Command

3.5 idle characters	Slave address (01H)	Function code (06H)	Data item (0032H)	Number of data (07D0H)	Error check CRC-16 (2BA9H)	3.5 idle characters
	1	1	2	2	2	←character number

•Response message from slave in normal status

3.5 idle characters	Slave address (01H)	Function code (06H)	Data item (0032H)	Number of data (07D0H)	Error check CRC-16 (2BA9H)	3.5 idle characters
	1	1	2	2	2	←character number

<3> Reset integral electric power (0064H, 0065H:2-word) of address 1

(When setting to 0 [0000, 0000H])

• Command

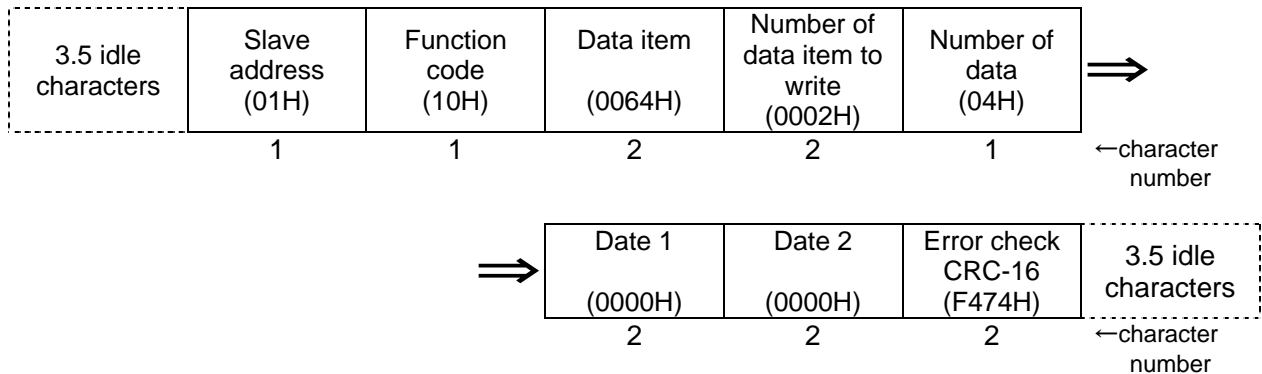

• Response message from slave in normal status

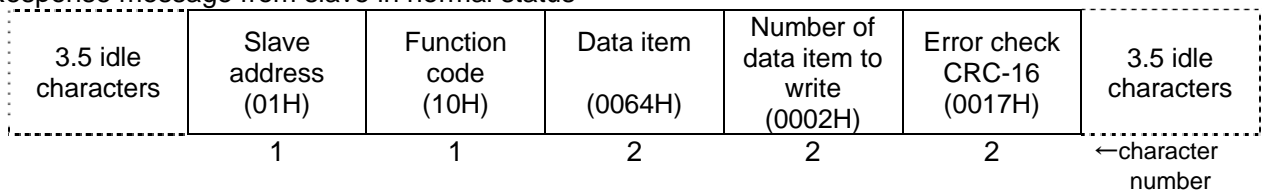

• A response message from the slave in exception (error) status

(When number of data has been mistaken.)

Function code MSB is set to 1 for the response message in exception (error) status (90H).

The exception code 03H (Value out of the device numbers) is returned as contents of error.

<Mistaken message example (Command)>

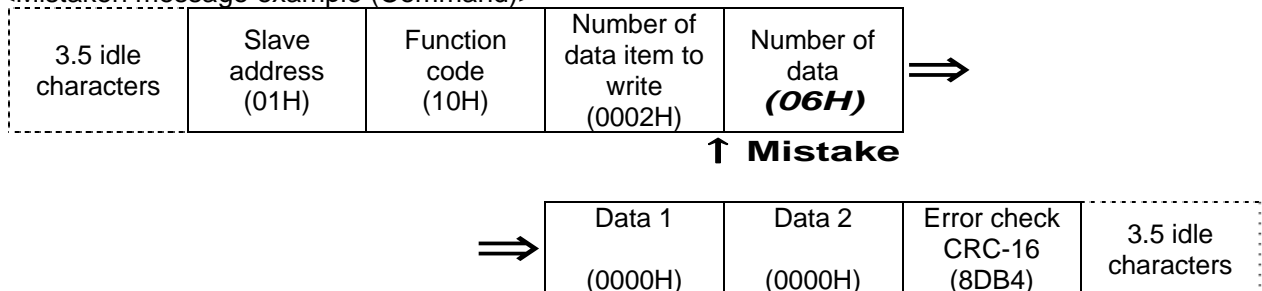

<Response message from slave to mistaken command

(Response message in exception (error) status)>

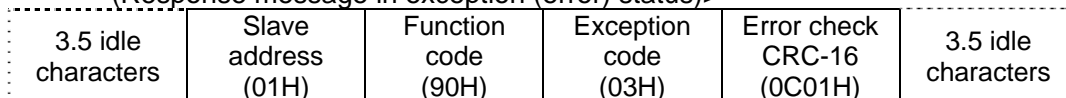

7.4.2 Data Register List

Data item (MEWTOCOL)	Name	Unit	Kind of date	Range: Hexadecimal (Range: Decimal)	MODBUS Function code
0032H (DT00050)	Rate ¥(JPY)	0.01	Unsigned 16bit	0H to 270FH (0 to 9999)	03H/06H/10H
0033H (DT00051)	Rate \$	0.001\$	Unsigned 16bit	0H to 270FH (0 to 9999)	03H/06H/10H
0034H (DT00052)	Rate €(EUR)	0.001€	Unsigned 16bit	0H to 270FH (0 to 9999)	03H/06H/10H
0035H (DT00053)	Rate yuan (CNY)	0.01CNY	Unsigned 16bit	0H to 270FH (0 to 9999)	03H/06H/10H
0036H (DT00054)	Rate No currency (CHG)	0.01	Unsigned 16bit	0H to 270FH (0 to 9999)	03H/06H/10H
0037H (DT00055)	Conversion factor (CO2)	0.001 kg-CO ₂	Unsigned 16bit	0H to 270FH (0 to 9999)	03H/06H/10H
0064H (DT00100)	Integral active power	0.01kWh	Unsigned 32bit	0H to 3B9AC9FFH (0 to 999999999)	03H/06H/10H
0065H (DT00101)					
006BH (DT00107)	Current L1A (CT1)	0.1A	Unsigned 16bit	0H to 270FH (0 to 9999)	03H
006CH (DT00108)	Current L2A (CT2)	0.1A	Unsigned 16bit	0H to 270FH (0 to 9999)	03H
003CH (DT00060)	CT type	Rated A (rms)	Unsigned 16bit	5H(5), 32H(50), 64H(100), FAH(250), 190H(400)	03H/06H/10H
003DH (DT00061)	Unit for Pulse output	—	Unsigned 32bit	1H(1)<0.001>, AH(10)<0.01>, 64H(100)<0.1>, 3E8H(1000)<1>, 2710H(10000)<10>, 186A0H(100000)<100>, 3E7H(999) <Instantaneous electric power: Values of 0040H, 0041H>	03H/06H/10H
003EH (DT00062)					
003FH (DT00063)	Primary side current value when CT 5A	1A	Unsigned 16bit	1H to FA0H (1 to 4000)	03H/06H/10H
0040H (DT00064)	Alarm value (Instantaneous active power)	0.01kW	Unsigned 32bit	0H to F423FH (1 to 999999)	03H/06H/10H
0041H (DT00065)					
0042H (DT00066)	VT ratio	0.01	Unsigned 16bit	64H to 270FH (100 to 9999)	03H/06H/10H
0043H (CT00067)	Current threshold for time measurement	0.1%	Unsigned 16bit	AH to 3E8H (10 to 1000)	03H/06H/10H
0044H (DT00068)	Cutoff current	0.1%	Unsigned 16bit	AH to 1F4H (10 to 500)	03H/06H/10H
0096H (DT00150)	Load ON-time	0.1h	Unsigned 32bit	0H to F423FH (0 to 999999)	03H/06H/10H
0097H (DT00151)					
0098H (DT00152)	Load OFF-time	0.1h	Unsigned 32bit	0H to F423FH (0 to 999999)	03H/06H/10H
0099H (DT00153)					

009AH (DT00154)	Pulse count value	—	Unsigned 32bit	0H to F423FH (0 to 999999)	03H/06H/10H
009BH (DT00155)					
009EH (DT00158)	Preset value	—	Unsigned 32bit	0H to F423FH (0 to 999999)	03H/06H/10H
009FH (DT00159)					
00A0H (DT00160)	Pre-scale value	0.001	Unsigned 32bit	1H to 186A0H (1 to 100000) * Decimal point is fixed.	03H/06H/10H
00A1H (DT00161)					
00A2H (DT00162)	Max. counting speed	Hz	Unsigned 16bit	1EH (30), 7D0H (2000)	03H/06H/10H
00A3H (DT00163)	Auto-off time	min	Unsigned 16bit	0H to 63H (0 to 99)	03H/06H/10H
00A4H (DT00164)	Display unit	—	Unsigned 16bit	0H(0):CNT, 1H(1): l, 2H(2): kl, 3H(3): m3	03H/06H/10H
00AAH (DT00170)	Voltage L1V (Between 1 and 2)	0.1V	Unsigned 32bit	0H to 1869FH (0 to 99999)	03H
00ABH (DT00171)					
00ACH (DT00172)	Voltage L2V (Between 2 and 3)	0.1V	Unsigned 32bit	0H to 1869FH (0 to 99999)	03H
00ADH (DT00173)					
00B0H (DT00176)	Instantaneous power	0.01kW	Unsigned 32bit	0H to F423FH (0 to 999999)	03H
00B1H (DT00177)					

note 1) 03H: Read 06H/10H: Write

note 2) Data register except specified is "0".

note 3) If each setting value is wrote by communication, it memories to internal EEP-ROM at the same time. Therefore, change setting frequently makes EEP-ROM's life short. Avoid to usage like this.

note 4) Write a data within the range when you write it.

Chapter 8 Specifications

8.1 Main unit

Rated operating voltage	100-120V AC / 200-240V AC	
Rated frequency	50/60Hz common	
Rated power consumption	8VA	
Allowable operating voltage range	85-132/170-264V AC (85 to 110% of rated operating voltage)	
Allowable momentary power-off time	10ms	
Ambient temperature	-10 to +50°C (-25 to +70°C at storage)	
Ambient humidity	30 to 85%RH (at 20°C) non-condensing	
Breakdown voltage (initial)	Between the isolated circuits: 2000V for 1min Cut-off current: 10mA	【Use as a Power meter】 • Insulated circuit (Between [A] - [B],[B] - [C],[A] - [C]) [A] Power terminal (1(R),2(N,S),3(T)), CT input terminal (CT1(+),CT2(+),CT1,2(-)) [B] RS-485 terminal(+,-) [C] Pulse output terminal(+,-) • Outer edge (enclosure) — all terminals
Insulation resistance (initial)	Between the isolated circuits: 100MΩ or more (measured with 500V DC)	【Use as a Pulse counter】 • Insulated circuit (Between [A]-[B], [B]-[C], [A]-[C]) [A] Power terminal (1(R),2(N)), Pulse input terminal (CT1 (+), 0V), [B] RS-485 terminal (+,-) [C] Pulse output terminal (+,-) • Outer edge (case) — all terminals
Vibration resistance	10 to 55Hz (1cycle/min) single amplitude: 0.75mm(1h on 3 axes)	
Shock resistance	Min. 294m/s ² (5 times on 3 axes)	
Display method	6-digit, 7-segment LCD with backlight (Setting value) 4-digit, 16-segment (Mode) LCD Upper section: Green, Lower section: Amber	
Power failure memory method	EEP-ROM (more than 100,000 overwrite)	
Protection	IEC Standard IP66 (only front panel with rubber gasket) Note) Mounted in a row, waterproofing property will be lost.	
Weight	approx.130g (11-pin type), approx.140g (Screw terminal type)	

8.2 Input Specifications

8.2.1 Power Input

Phase and wire system		Single-phase two-wire system Single-phase three-wire system (common) Three-phase three-wire system	
Input voltage	Rating	Single-phase two-wire : 100-120/200-240V AC (common) Single-phase three-wire : 100-120V AC Three-phase three-wire : 100-240V AC	
	Allowance	85 to 110% of rated input voltage	
	Allowable measurement voltage	Single-phase two-wire : 85-132/170-264V AC (common) Single-phase three-wire : 85-132V AC Three-phase three-wire : 85-264V AC	
	VT ratio	1.00 to 99.99 (Set with setting mode) *Voltage transformer (VT) is required when you measure a load with voltage over 240VAC (Allowable measurement voltage). *Secondary voltage rating of VT is 110V.	
Input current	Primary side rating	<Using the dedicated CT> ·5A/50A/100A/250A/400A (Select with setting mode) <Using a commercial CT with the secondary side current 5A> ·1 to 4000A (Set with setting mode) *Use a CT with secondary side current of 5A when measure 400A or more.	
Special functions	Cut-off current	1.0 to 50.0%F.S	
	Hour meter threshold current	1.0 to 100.0%F.S	
Accuracy (without error in CT and VT)	Basic accuracy	Instantaneous electric power / Integral electric power / Electricity charge / Conversion value ----- Within \pm (2.0 % F.S. + 1 digit) (at 20 °C, rated input, rated frequency, power factor 1) In case of 5 A CT mode, within \pm (2.5 % F.S. + 1 digit) *Accuracy coverage:5 to 100% of rated current	
		Current ----- Within \pm (1.0 % F.S. + 1 digit) In case of 5 A CT mode, within \pm (2.5 % F.S. + 1 digit) (at 20 °C rated input, rated frequency, power factor 1) *Accuracy coverage: 5 to 100 % of rated current	
		Voltage ----- Within \pm (1.0 % F.S. + 1 digit) (at 20 °C rated input, rated frequency, power factor 1)	
		Hour Meter ----- \pm 0.01% \pm 1digit (at 20°C) (In case power on start or current energizing, \pm 0.01%+1s \pm 1 digit)	
		Temperature characteristics	Within \pm (1.0 % F.S.+ 1 digit) In case of 5 A CT mode, within \pm (1.5 % F.S. + 1 digit) (Range of -10 to 50 °C 14 to 122 °F, rated input, power factor 1)
		Frequency characteristics	Within \pm (1.0 % F.S. + 1 digit) In case of 5 A CT mode, within \pm (1.5 % F.S. + 1 digit) (Frequency change \pm 5 % based on rated frequency, rated input, power factor 1)

8.2.2 Pulse input specifications

Input mode	Addition (Fixed)	
Max. counting speed	2kHz /30Hz (Select with setting mode)	
Pulse input	Min. input signal width: 0.25ms (When selected 2kHz) /16.7ms (When selected 30Hz) ON:OFF ratio = 1 : 1	
Input signal	Contact / No contact (open collector) • Impedance when shorted: 1kΩ • Residual voltage when shorted: Max. 2V • Impedance when open: 100kΩ	
Output mode	HOLD (Over count)	
Number of Digit	6-digit (0 to 999999) (Selectable with setting mode)	
Pre-scale setting	Decimal point	Set to 3rd decimal places (Auto-setting)
	Range	0.001 to 100.000 (Selectable with setting mode)
	Unit	「CNT」/「I」/「kI」/「m3」 (Selectable with setting mode) (Count value does not change even if the unit setting is changed during counting.)

8.3 Pulse output (Transistor output) Specifications

Number of output point	1 point	
Insulation method	Optical coupler	
Output type	Open collector	
Output capacity	100mA 30V DC	
Pulse width	approx. 10ms *	
ON state voltage drop	1.5V or less	
OFF state leakage current	100 μ A or less	
Pulse output unit	Power measurement	0.001/0.01/0.1/1/10/100kWh/Alarm (Selectable with setting mode)
	Pulse measurement	HOLD (Over count)

* We recommend the setting of minimum unit for pulse output for measurement shown as below.
Output pulse: 4 pulse or less per 1sec.

How to calculate

(Unit for pulse output: PL-P) > (Max. measurement power [kW]) / (3600[s] × 4 [pulse/s])

- Caution** (1) Improper unit setting may cause miss counting.
(2) If the OFF time is too short, there is a possibility of counting errors.

8.4 Communication Specifications

Interface	Conforming to RS-485	
Protocol	MEWTOCOL/MODBUS (RTU) (different model)	
Isolation status	Isolated with the internal circuit	
Number of connected units	99 (max.) ※1 ※2	
Transmission distance	1200m	
Transmission speed	38400/19200/9600/4800/2400bps (selectable with setting mode)	
Transmission Format	Data length	8bit/7bit (selectable with setting mode) (MEWTOCOL type) 7bit (fixed) (MODBUS type)
	Parity	Not available/Odd number/Even number (selectable with setting mode)
	Stop bit	1bit (fixed)
Communication method	Half-duplex	
Synchronous system	Synchronous communication method	
Ending resistance	Approx. 120 Ω (built-in) ※3	

- ※1 For RS-485 converter on the computer side, we recommend SI-35 (from LINE EYE Co.,Ltd.).
- ※2 When using SI-35, SI-35USB or PLC from our company (which can be connected up to 99 units), up to 99 Eco-POWER METER can be connected.
In case using this system with the other devices, up to 31 Eco-POWER METER can be connected.
- ※3 Change the sliding switch of main unit as a terminal station. (Factory setting; General side)

8.5 Self-diagnostic function

If an error occurs, the following indication will be given.

Indicator	Meaning	Output status	To recover
Err-00	CPU error	OFF	Turn the power off and then on again.
Err-01	Memory error*		EER-ROM life ended. Replace the unit.

*Includes the possibility that the EEP-ROM's life has expired.

8.6 Applicable standard

Safety standard	EN61010-1		
EMC	EMI EN61326-1	Radiation interference field strength Noise terminal voltage	CISPR11 class A CISPR11 class A
	EMS EN61326-1	Static discharge immunity RF electromagnetic field immunity EFT/B immunity Surge immunity Conductivity noise immunity Power frequency magnetic field immunity Voltage dip / Instantaneous stop / Voltage fluctuation immunity	EN61000-4-2 EN61000-4-3 EN61000-4-4 EN61000-4-5 EN61000-4-6 EN61000-4-8 EN61000-4-11

8.7 Dedicated Current Transformer Specifications

● Clamp-on type

Model No	AKW4801C	AKW4802C	AKW4803C	AKW4804C
Primary side rated current	5A / 50A	100A	250A	400A
Secondary side rated Current	1.67mA / 16.7mA	33.3mA	125mA	200mA
Transform ratio	3000:1	3000:1	2000:1	2000:1
Ratio error	±2.0% F.S.			
Hole Dia (mm)	φ 10	φ 16	φ 24	φ 36
Breakdown voltage (initial)	AC1000V/1min (Between through hole and output lead wire)		AC2000V/1min (Between through hole and output lead wire)	
Insulation resistance (initial)	Min. 100MΩ (at DC500V) (Between through hole and output lead wire)			
Vibration resistance	Functional	10 to 55Hz (1 cycle/ minute) single amplitude of 0.15mm (10 min. on X,Y and Z axes)		
	Destructive	10 to 55Hz (1 cycle/ minute) single amplitude of 0.375mm (1 hrs. on X,Y and Z axes)		
Shock resistance	Functional	Min. 98m/s ² (4 times on X,Y and Z axes)		
	Destructive	Min. 294m/s ² (5 times on X,Y and Z axes)		
Output protection level	±7.5V with clamp element		±3.0V with clamp element	
Permissible clamping frequency	Approx. 100 times			
Ambient temperature	-10 to +50°C (without frost and non-condensing)			
Storage temperature	-20 to +60°C (without frost and non-condensing)			
Ambient humidity	30 to 85%RH (at 20°C) non-condensing			
Weight (with relay cable)	Approx. 60g	Approx. 90g	Approx. 200g	Approx. 295g

● Through type

Model No		AKW4506C	AKW4507C
Primary side rated current		50A / 100A	250A / 400A
Secondary side rated Current		16.7mA / 33.3mA	125mA / 200mA
Transform ratio		3000:1	2000:1
Ratio error		±1.0%F.S.	
Hole Dia (mm)		φ 17	φ 36
Breakdown voltage (initial)		AC1000V/1min (Between through hole and output lead wire)	AC2000V/1min (Between through hole and output lead wire)
Insulation resistance (initial)		Min. 100MΩ (at DC500V) (Between through hole and output lead wire)	
Vibration resistance	Functional	10 to 55Hz (1 cycle/ minute) single amplitude of 0.15mm (10 min. on X,Y and Z axes)	
	Destructive	10 to 55Hz (1 cycle/ minute) single amplitude of 0.375mm (1 hrs. on X,Y and Z axes)	
Shock resistance	Functional	Min. 98m/s ² (4 times on X,Y and Z axes)	
	Destructive	Min. 294m/ s ² (5 times on X,Y and Z axes)	
Output protection level		±7.5V with clamp element	±3.0V with clamp element
Ambient temperature		-10 to +50°C (without frost and non-condensing)	
Storage temperature		-20 to +60°C (without frost and non-condensing)	
Ambient humidity		30 to 85%RH (at 20°C non-condensing)	
Weight (with relay cable)		Approx. 70g	Approx. 200g

Note) Dedicated current transformers (CT) are dedicated for low voltage under 440V. They can not be used for high voltage circuit. In case measuring high voltage circuit, make a 2-step construction by combination of a commercial CT of secondary side current 5A for high voltage and the dedicated CT for 5A.

Chapter 9 Mounting

9.1 Dimensions

(Unit: mm)
(Clearance: ±1.0)

9.1.1 Main unit

◆Screw terminal type (AKW5111)

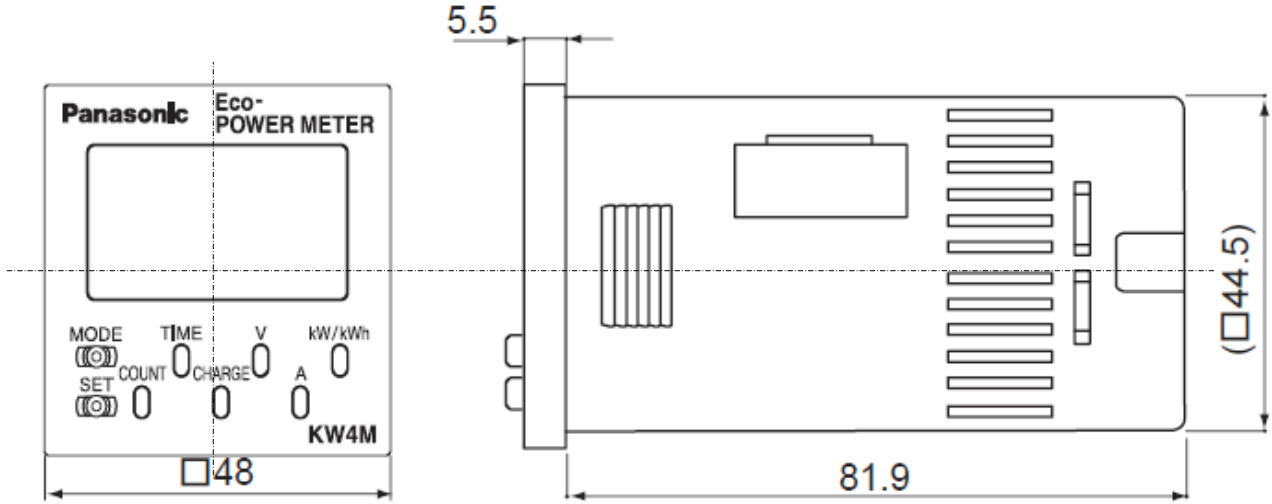

◆Pin type (AKW5211)

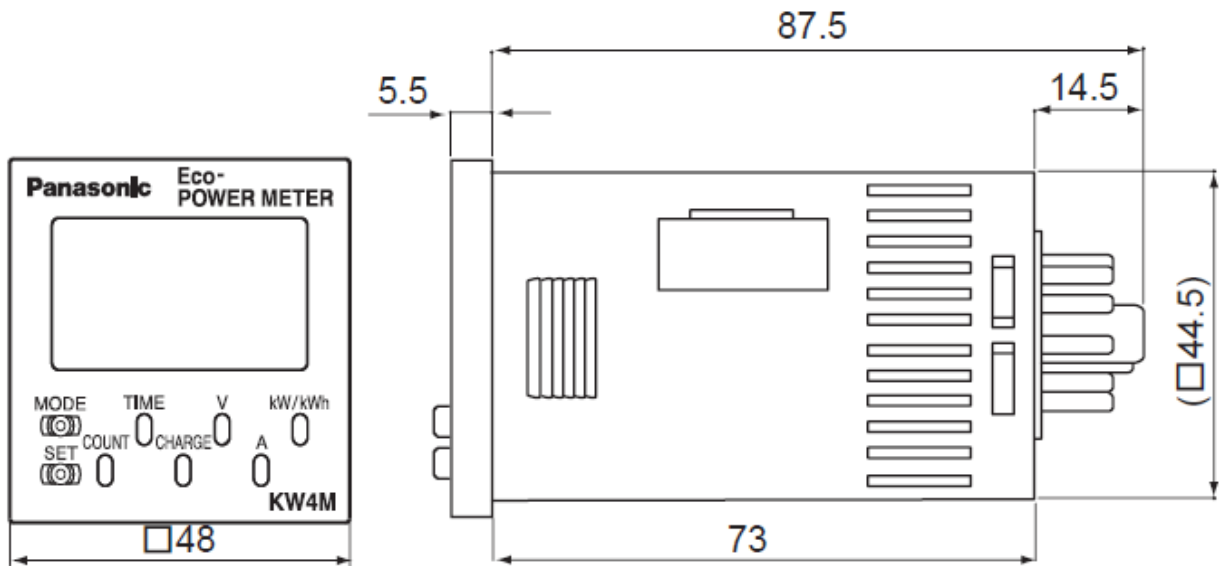

◆ Panel Cut-out dimensions

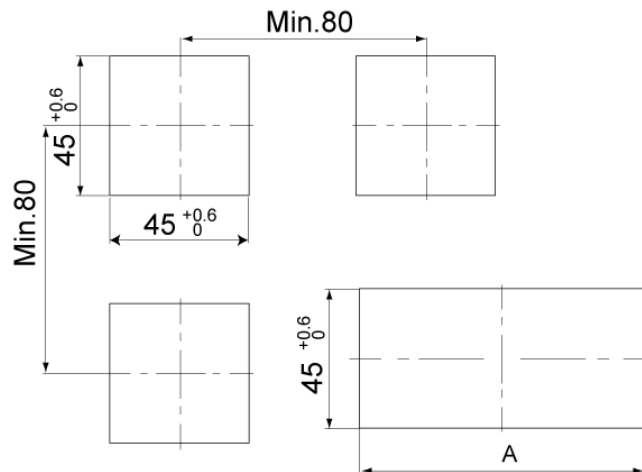

Dimension A when 'u' products are mounted in a row: $A = (48 * n - 2.5)^{+0.6}_0$
 If the products are mounted in a row, they lose their waterproofing properties.

◆ Panel mounting diagram

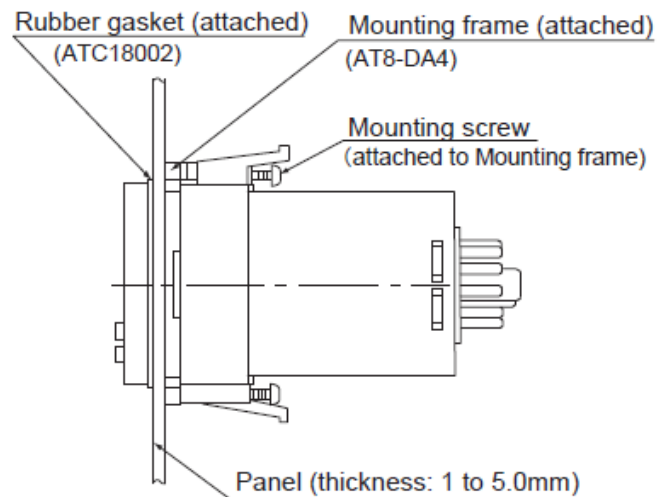

How to mount

From the panel front, pass the main unit through the square holes. Insert the mounting frame from the rear and push it in so that the gap between the mounting frame and the panel surface is minimized. Tighten the screws (2 places) equally tight and check that there is no rattling. If the screws are overly tightened, the frame may come off. In that case, loosen the screws and tighten them again pushing the frame in.

9.1.2 Dedicated CT

◆ For 5A/50A (AKW4801C)

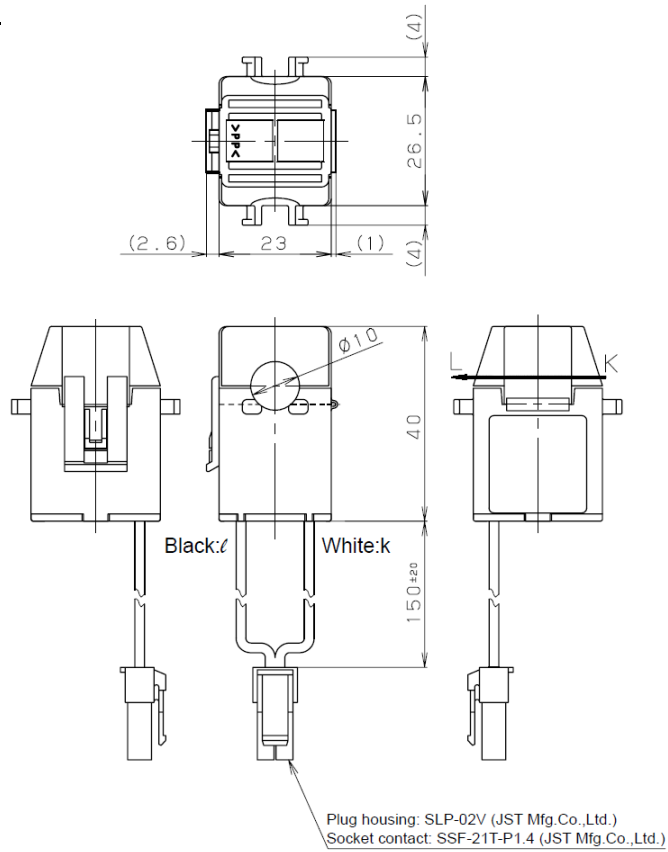

◆ For 100A (AKW4802C)

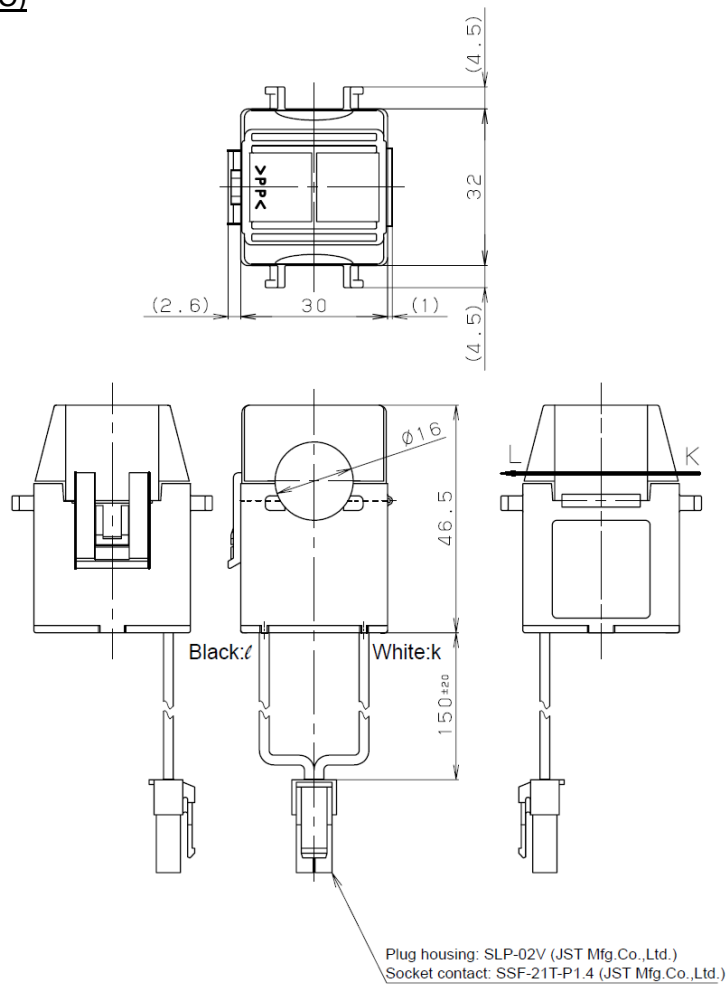

◆ For 250A (AKW4803C)

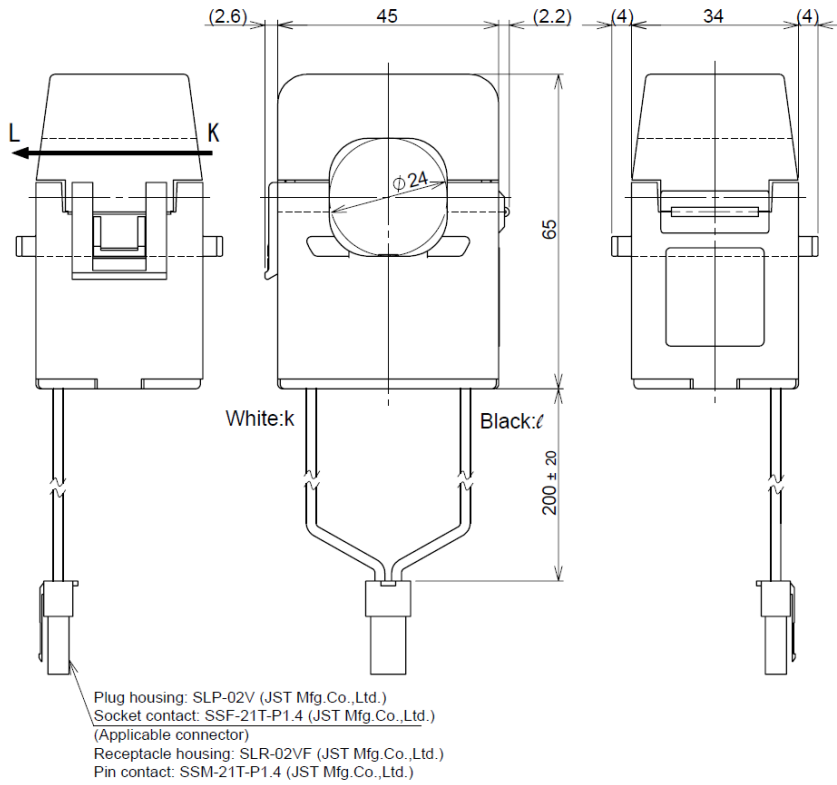

◆ For 400A (AKW4804C)

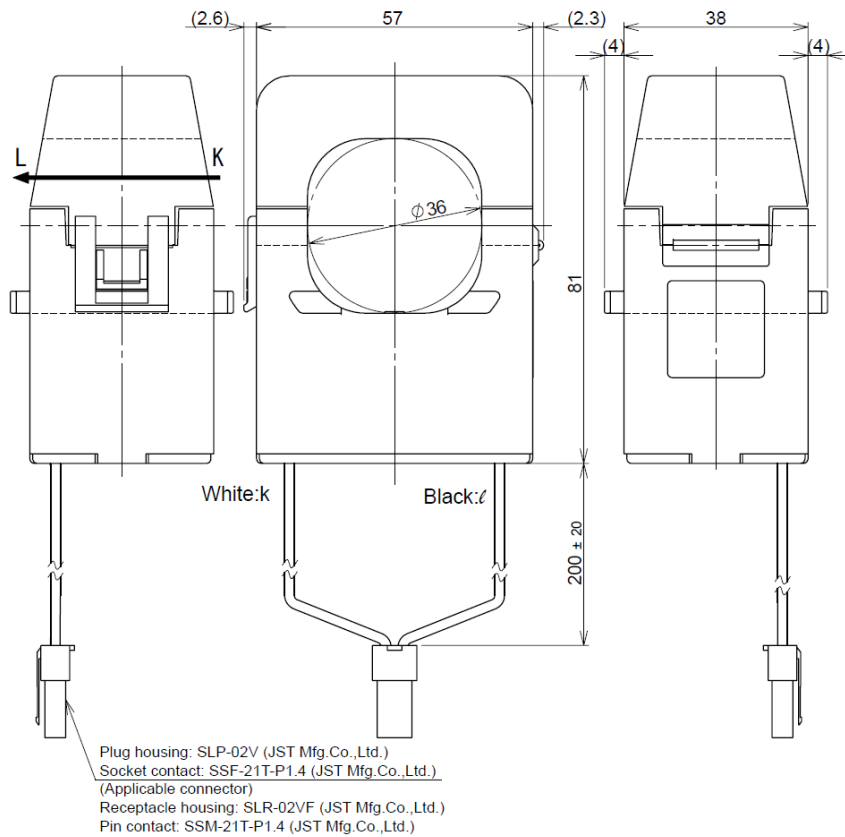

◆ For 50A/100A (AKW4506C)

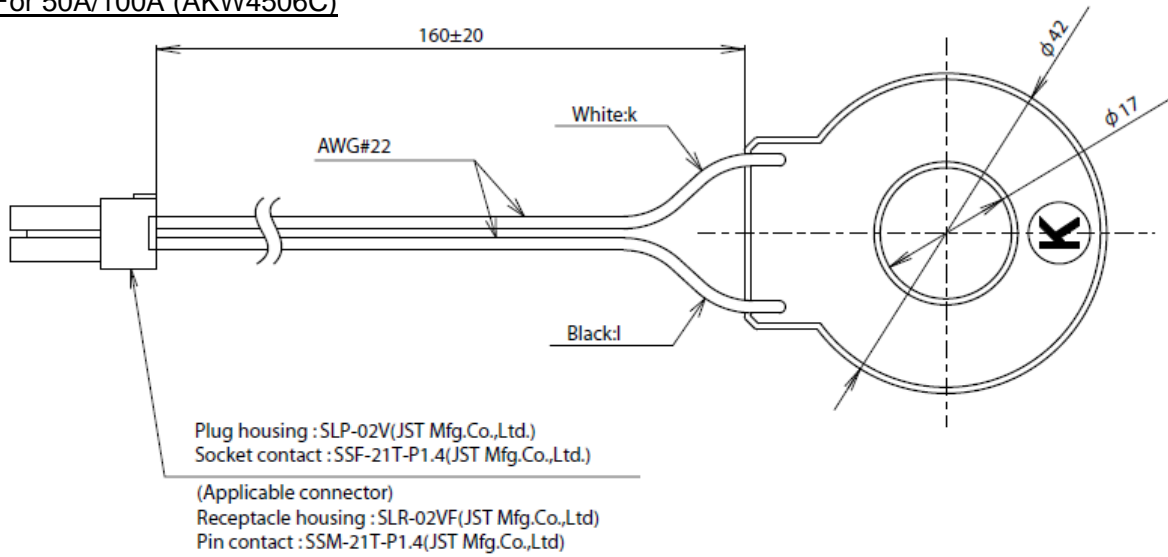

◆ For 250A/400A (AKW4507C), For 600A (AKW4508C)

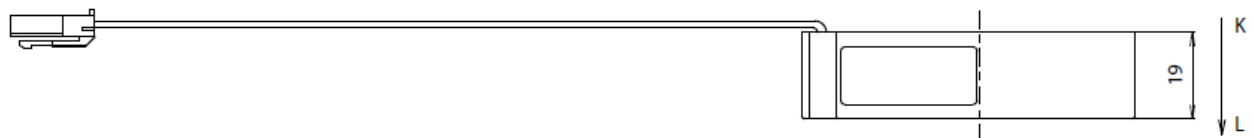
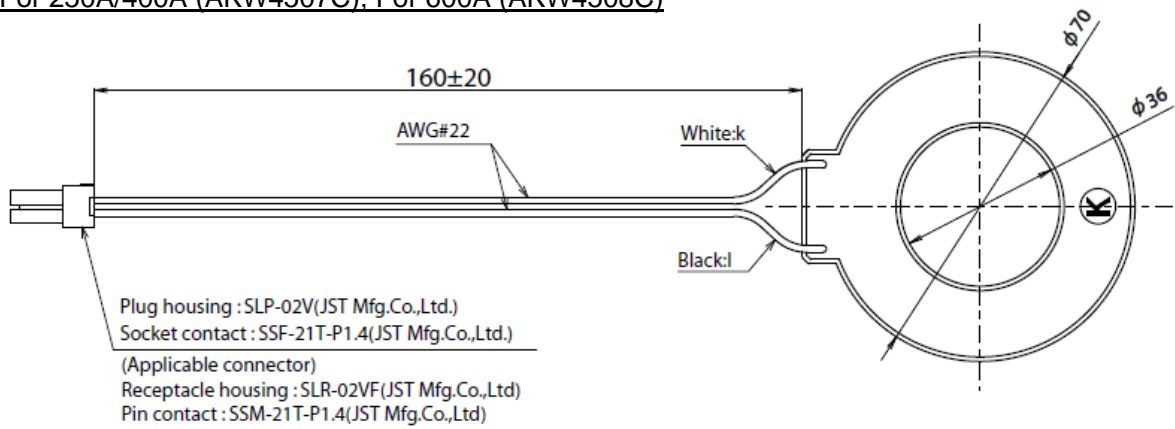

◆ Attached trunk cable (common)

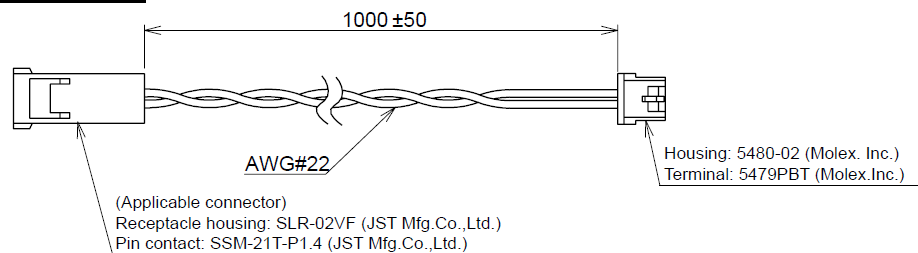

Chapter 10 Q&A

Q & A

Q1	I'd like to measure by Eco-POWER METER. Measured load is 50 to 60A in normal operation. But the inrush current is 130 to 140 A. Which CT is selected? (100A or 250A)
A1	Select 100ACT. Stable current more than 1 second is necessary to measure. The inrush current seems to be a few ms, therefore it can't measure it. In case there is current over 1 second (inrush current), it measures it and select 250A CT.
Q2	Current and voltage are displayed. But it can't measure an electric power.
A2	<ul style="list-style-type: none"> •Do you install CT to the correct position and correct direction? CT has directions. Install CT according to the direction marked. From power supply side (K) to load side (L). •Do you wire measurement voltage input correctly? When phases of voltage and current are not matched, it can't measure correctly. Please check the wiring.
Q3	How long do I extend CT cable?
A3	You can extend up to about 10 m with cable of AWG#22 or more. We can't guarantee the specifications if you extend more than 10m.
Q4	How do you guarantee the accuracy of measurement with low current range?
A4	Up to 5% for CT rating. In case of CT50A, it guarantees for an electric power with current 2.5A or more.
Q5	How long do I extend pulse input cable?
A5	You can extend up to 10m with shielded wire or a metallic electric wire tube individually.
Q6	What do I use the function of primary side current of CT for?
A6	It is assumed that the use for 2 nd stage CT with combination of CT. You set the primary side current of 1 st stage CT (refer to mode1). In order to measure a large capacity current such as 1000A, it converts to 5A (small current) and measures the load.
Q7	Are there any attachments in order to fix CT?
A7	Sorry but there is no attachment.
Q8	Eco-POWER METER measures only voltage and current. How is it measure an electric power? What is the reason why it can't measure when CT is connected wrong direction?
A8	Electric power is calculated using instantaneous voltage and instantaneous current. When CT is connected wrong direction, it measures minus value in fact, but it displays 0kW with Eco-POWER METER.

Revision History

Issue Date	Manual no.	Content of revision
June, 2005	ARCT1F413E	1 st edition
October, 2007	ARCT1F413E-1	2 nd edition 6-3 Wiring: Add the explanation in detail.
March, 2008	ARCT1F413E-2	3 rd edition MODBUS type series addition <ul style="list-style-type: none"> • Model No. • MODBUS communication • MODBUS specifications
October, 2008	ARCT1F413E-3	4 th edition <ul style="list-style-type: none"> • Change company name • New function addition Display of charge, CHG and CO2 Transmission speed (38400bps) • Optional parts addition AKW4822 Installation frame AKW4823 Terminal protective cover
January, 2012	ARCT1F413E-4	5 th edition <ul style="list-style-type: none"> [Improve spec.] Improve the accuracy [Correct error] output connection wiring
July, 2013	ARCT1F413E-5	6 th edition Company name change

Please contact

Panasonic Industrial Devices SUNX Co., Ltd.

■ Overseas Sales Division (Head Office): 2431-1 Ushiyama-cho, Kasugai-shi, Aichi, 486-0901, Japan

■ Telephone: +81-568-33-7861 ■ Facsimile: +81-568-33-8591

panasonic.net/id/piddsx/global

About our sales network, please visit our website.

© Panasonic Industrial Devices SUNX Co., Ltd. 2013

Specifications are subject to change without notice.

ARCT1F413E-5