

# RL2000

## REFERENCE LEAK



**User's manual**

## Contents

1. Safety .....	3
2. Contents of delivery .....	4
3. Quick guide for calibration of hand probes .....	5
3.1. Installing the leak .....	5
3.2. Setting pressure .....	7
3.3. Purging leak .....	7
3.4. Setting calibration parameters in the Sensistor ISH2000 Detector .....	7
3.5. Calibrating.....	7
4. Setting up your leak .....	8
4.1. The certificate .....	8
5. Caring for your leak .....	9
6. Recalibration of your reference leak.....	9
7. Trouble-shooting.....	10
8. Conversion Table for Pressure Units .....	11
9. Conversion Table for Flow Units .....	12
10. Specifications.....	13

## 1. Safety

Hydrogen is not flammable when diluted sufficiently with nitrogen. It is at this stage that the international standard ISO 10156 classifies the recommended tracer gas mix (5% Hydrogen / 95% Nitrogen) as non-flammable.

Three safety aspects, however, must be considered when working with the recommended tracer gas mix.

- Compressed gas contains large amounts of energy. Failure of connectors, hoses etc can result in serious personal injury. This warning is valid for all compressed gases, including air.
- The tracer gas mix contains no oxygen. Releasing large amounts of gas in a confined space can lead to asphyxiation and death. This warning is valid for all oxygen deficient gases including Nitrogen and Helium.
- Pure hydrogen mistakenly purchased is flammable! Check that your cylinder has a green label!



**Hazard**

The recommended tracer gas mixture contains no oxygen. Releasing large amounts of gas in confined spaces may displace the air and create a risk for asphyxiation.



**Hazard**

Compressed gases contain energy!  
Be very careful never to use higher pressures than specified for your coupling, hoses, regulators etc.

Maximum pressure for the leak itself is 3 MPa (30 bar).

## 2. Contents of delivery

Your delivery contains the following items (see figure below):

- Reference leak assembly comprising leak and purge valve assembly.
- Diffuser house (for hand probe calibration).
- Diffuser filter (2 off).
- White probe guide ring for calibration of probes with 8 mm tip.
- Black probe guide ring for calibration of probes with 10 mm tip.
- Red G1/8 gasket.
- Collet nut for connection to 1/4" tubing (marked red).
- 2.5 mm Allen key (hex drive) for purge valve and assembly of diffuser.
- Calibration certificate.
- Pressure correction curve.
- Delivery and storage box.
- This manual.

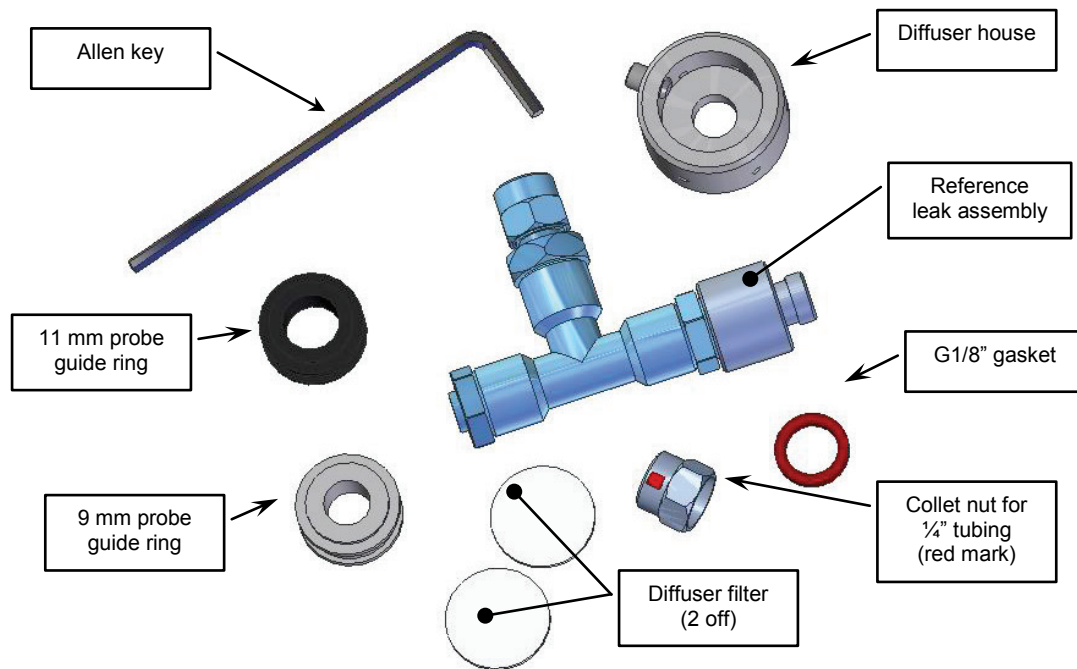

To use your leak you will also need the following:

- **Tracer gas.** This should be the identical to the gas as used for your leak test (typically 5% H<sub>2</sub> in 95% N<sub>2</sub>).
- **Pressure regulator** to set correct tracer gas pressure for feeding the leak.
- **Pressure gauge** (manometer) to monitor the setting of the pressure regulator. Remember that the calibration certificate is only valid if the correct pressure is fed to the leak! Use a gauge (or manometer) that reads correctly ( $\pm 2\%$  of reading or better).

### 3. Quick guide for calibration of hand probes

Below is a condensed step-by-step description in how to set up and use your reference leak to calibrate the range of hand held detector probes from INFICON.

If you have acquired the leak for other purposes, simply skip the non-applicable steps.

Detailed instructions for incorporating your leak in automated test systems etc are available from your supplier.

#### 3.1. Installing the leak

Before assembling the leak, we recommend that you make a copy of the certificate and the pressure correction curve. Keep the originals in a safe place.

- Choose the correct probe guide ring from the table below.

Probe configuration	Ring	Colour
Hand Probe H50 without tip protection cap.	9 mm	White
Hand Probe H50 with tip protection cap.	11 mm	Black
Sniffer Probe H55 (AP55 System)	11 mm	Black
Counter Flow Probe H57 (AP57 System)	11 mm	Black
Insertion Probe H65	9 mm	White
Other probes with 6 - 8.5 mm tip	9 mm	White
Other probes with 8.6 - 10.5 mm tip	11 mm	Black

- Assemble diffuser according to the figure below:

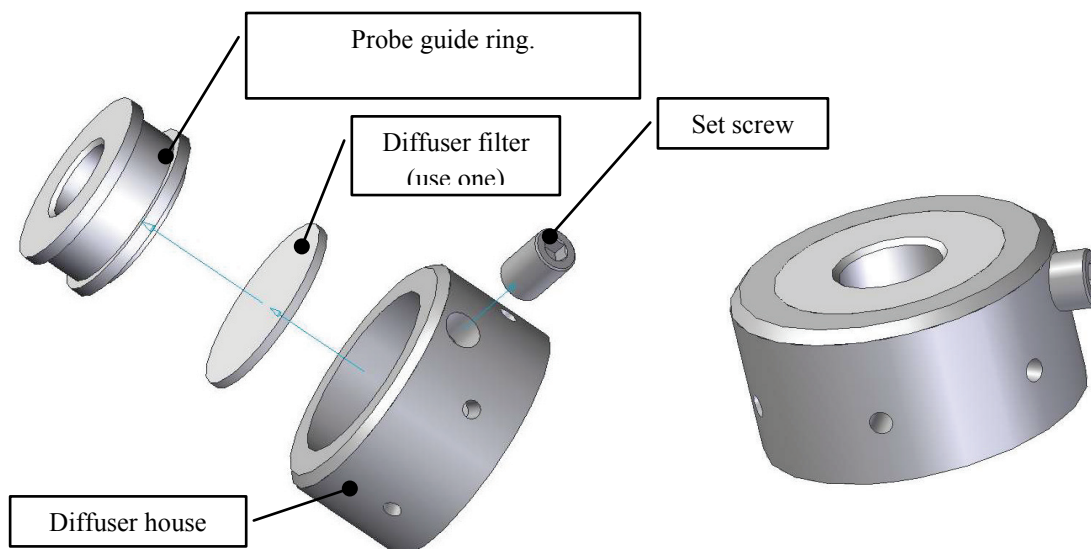

Install the leak in a panel if desired, or assemble diffuser and leak with red gasket as spacer. See figure below:

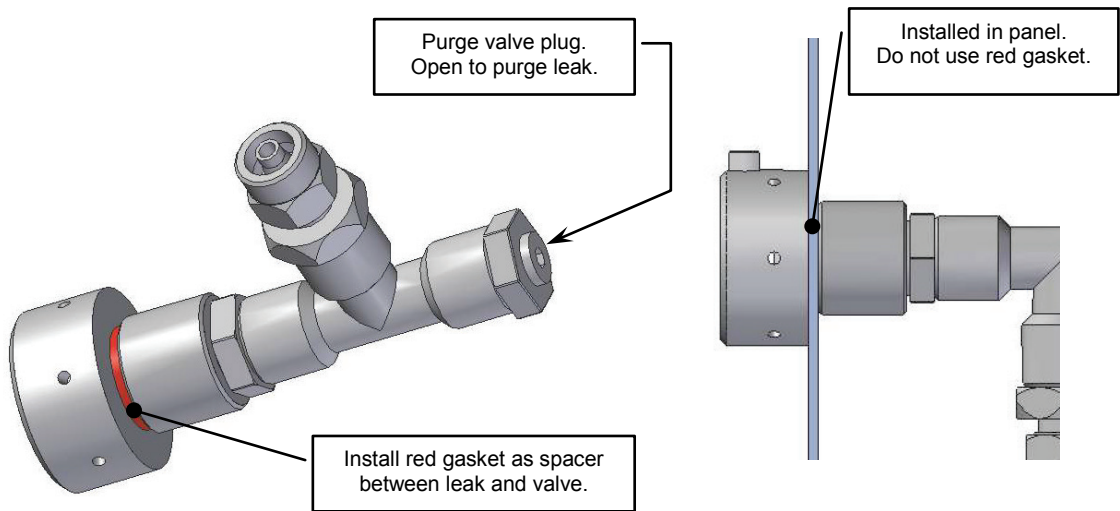

- Connect the leak to the tracer gas supply as shown in the figure below. Remember that the accuracy of your pressure regulator and gauge will directly influence the accuracy of your calibration.
- Use plastic pneumatic hose for tracer gas supply. The unmarked collet nut is for 6 x 4 mm hose. The nut with red mark is for 1/4" x 5/32" hose. Remove collet nut from coupling. Slide nut over end of hose with threads facing end of hose. Push hose fully on to connector, slide nut down and tighten by hand. Tighten the nut another 1/2 turn using a 12 mm key or adjustable spanner.

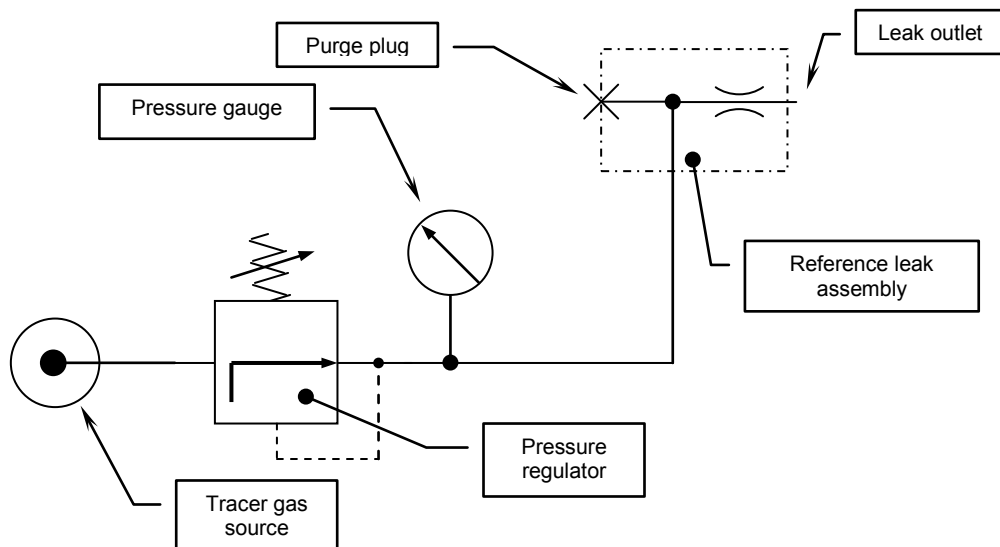

### 3.2. Setting pressure

- Set the regulator to the pressure indicated on the calibration certificate. See further under “*Setting up your leak*” below.

### 3.3. Purging leak

- Open the purge valve (see figure above) for a few seconds to bleed out all remaining air in the hoses.
- Close the purge valve firmly.
- Check the pressure gauge again and readjust pressure if necessary.

Leak is ready to use just a few seconds after it has been purged.

### 3.4. Setting calibration parameters in the Sensistor ISH2000 Detector

- Set *Calibration Time* to 10 s (standard value). For probes other than passive hand probes, refer to the respective probe manual.
- Set *Calibration Coefficient* to calibrated leak rate value stated on the calibration certificate.
- Set the *Leak rate unit* to that specified on the calibration certificate.  
(You may also use other flow units. Use the flow conversion table below. Remember though, to recalculate the leak rate value. The *Calibration Coefficient* must be changed to the new value.

See further in the “*Sensistor ISH2000 PLUS Use’sr Manual*”.

### 3.5. Calibrating

- Start the calibration from the Sensistor ISH2000 menu (or by operating switch on front of APC unit).
- When the bar on the display starts growing, quickly insert probe into diffuser , maintaining a straight connection. See figure below:

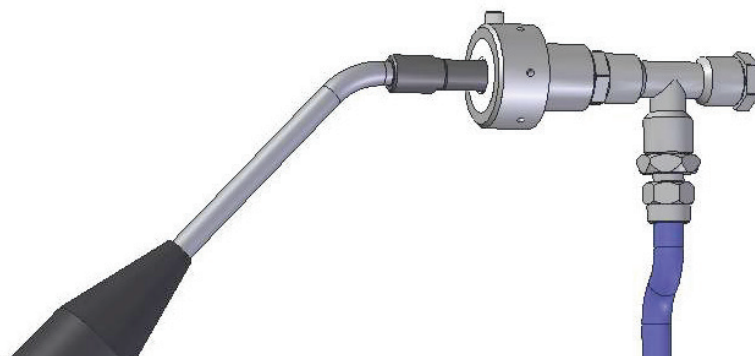

- Remove probe when detector has analysed the gas.
- If detector asks you to re-calibrate, wait > 30s and then calibrate again.
- If detector indicates “Calibration OK”, press Save.

## 4. Setting up your leak

### 4.1. The certificate

Page 1 of 1

**ION SCIENCE** INNOVATION  
**ION SCIENCE LIMITED** The Way, Fowlmere, Cambridge SG8 7UJ  
 Telephone: +44 (0) 1763 208503 Facsimile: +44 (0) 1763 208814

### CALIBRATION CERTIFICATE

Date of Calibration: - 8<sup>th</sup> January 2006 Certificate Number: - 206837  
 Calibrated by: - N O'Regan Signed: -  
 Customer: - Sensistor Technologies AB  
 Description: - Standard Calibrated Leak  
 Manufacturer: - ION Science Ltd  
 Type Number: - SCL  
 Serial Number: - **SCL1113**

Status of instrument upon receipt: -  
 Correct Working Condition  
 Minor Work Required  
 Incorrect Operation or Mechanically Broken

Measurement Standards are derived from volumetric and time sources, which are themselves traceable to UKAS (NAMAS). The relevant procedures are recorded and are available for inspection if required. The following list indicates the identification numbers of traceable items used during the calibration procedure.

THE66	D601	SCL01	258	FLOW01	ST02
BAR01					

The instrument has been calibrated at a temperature of 19.0°C ± 0.25°C and a barometric pressure of 1021.9 mbar ± 2 mbar.  
 ION Science hereby certify that on the day of calibration the instrument was working according to the manufacturer's original sales specification as checked by the calibration procedure, unless otherwise stated.

#### RESULTS AFTER ADJUSTMENT

Applied Pressure	Measured Flow
1 Bar Air	5.3 x 10 <sup>-3</sup> ml/sec

The estimated measurement uncertainty is ± 2.0%

Comments: -

**INNOVATION**  
 INDUSTRIAL LEAK DETECTION SOLUTIONS  
 Registered in England No. 2359036 VAT No. 532 2024 00  
 Email: calibration@ionscience.com Website: www.ionscience.com

The first thing you must look at when setting up your leak is the leak specification. This must be correctly correlated to the data on the calibration certificate.

- Check for what gas the leak limit is specified.
- Check that the certificate quotes this gas. If not you must recalculate the corresponding flow for this gas. Ask your supplier for assistance.
- Read the calibrated leak flow stated on the certificate.
- Check what upstream (inlet) pressure the leak is calibrated at.

**N.B.** The calibrated flow of the reference leak does not need to be exactly the same as the leak limit.

As long as the detector is set up correctly (see section 3.2 above) you will measure correctly within the leak limit.

We recommend that the flow of the reference leak is within 0.5 to 5 times the leak limit. However it should not be outside the range of 0.1 to 10 times the leak limit.



## 5. Caring for your leak

The leak is a precision instrument and a vital part of your quality assurance system. Handle it with care at all times. It is not necessarily sensitive to dust or dirt but we recommend that you follow the rules below to safeguard the function and accuracy of your leak.

- Do not expose the leak to liquids of any kind. Be particularly mindful of oil and other heavy, non-volatile compounds.
- Keep your probe tips clean so that you do not make the diffuser filter dirty. A dirty and partly clogged diffuser filter can reduce the leak flow.
- Change diffuser filter when it appears dirty.  
Extra filters can be ordered separately (part number T.B.A.).
- If you need to clean the exterior of the leak, use a lint free, textile cloth, wetted with pure alcohol (iso-propyl alcohol or ethanol). Make sure cloth is not too wet. It must not drip alcohol.
- Send in the leak for recalibration at regular intervals. See further below.



## 6. Recalibration of your reference leak

The type of sintered metal powder leaks delivered by INFICON is very stable and does not normally change with time unless they are contaminated with oil or dirt etc.

As it is not evident to the eye if such clogging has occurred, we recommend that you have the leak recalibrated at regular intervals.

Send the leak to your supplier or directly to INFICON, Sweden.

## 7. Trouble-shooting

Symptom	Cause	Remedy
No or low gas signal from leak.	Probe tip filter is clogged.	Replace external filter (white). Send in probe for service if bronze filter is clogged.
	Probe was not correctly inserted.	Insert probe according to section 3.5
	Residual air has not been purged out.	Purge leak. See section 3.3 above.
	Gas pressure is set too low.	Adjust gas pressure. See section 3.2
	Tracer gas is not connected.	Connect gas. See sections 3.1 through 3.3 above.
	Wrong gas connected.	Check that correct gas is connected. Gas should be identical to tracer gas used. Normally 5% H <sub>2</sub> / 95% N <sub>2</sub>
Detector calibration failed	Signal was different from last calibration.	Wait 30 s and try again. If failing more than 3 times see next symptom.
	Probe was not properly inserted	Insert probe according to section 3.5
	Probe tip filter is clogged.	Replace external filter (white). Send in probe for service if bronze filter is clogged.
Detector display shows: “Sensitivity too low for alarm level”.	Alarm level is set below detector or probe specification.	Set correct level. See User’s Manuals of Sensistor ISH2000 Detector and your AP unit (if not H50).
	Probe tip filter is clogged.	Replace external filter (white). Send in probe for service if bronze filter is clogged.
	Sensitivity of probe is too low.	Replace probe. Send defect probe for sensor replacement. Sensor in AP29 can be replaced by you.
Sensor status bar on detector display is shorter than earlier.	Probe tip filter is clogged.	Replace external filter (white). Send in probe for service if bronze filter is clogged.
	Sensor has lost some sensitivity.	This is normal after some time. Detector will let you know when sensitivity is too low.

## 8. Conversion Table for Pressure Units

**N.B.** A free physical unit converter software can be ordered from [reach.sweden@inficon.com](mailto:reach.sweden@inficon.com).

	bar	kp/cm <sup>2</sup> "kg/cm <sup>2</sup> "**	mwc** m H <sub>2</sub> O	PSI	inch Hg	MPa	inch H <sub>2</sub> O	mm Hg	mbar	cm H <sub>2</sub> O	mmwc** mm H <sub>2</sub> O
1 bar =	1	1.019	10.19	14.5	29.5	0.10	394	750	1000	1019	1.02x10 <sup>4</sup>
1 kp/cm <sup>2</sup> ="kg/cm <sup>2</sup> "*	0.981	1	10	14.2	28.9	0.0981	387	736	981	1000	10000
1mwc= 1 m H <sub>2</sub> O =	0.098	0.10	1	1.42	2.89	0.00981	38.7	73.6	98.1	100	1000
1 PSI =	0.069	0.070	0.70	1	2.04	0.00689	27.7	51.7	69	70.3	703
1 inch Hg =	0.0339	0.035	0.345	0.491	1	0.00339	13.6	25.4	33.9	34.5	345
1 MPa =	0.010	0.0102	0.102	0.145	0.295	1	4.02	7.5	10	10.2	102
1 inch H <sub>2</sub> O =	0.00249	0.0025	0.025	0.0361	0.0735	0.000249	1	1.87	2.49	2.54	25.4
1 mm Hg =	0.00133	0.00135	0.0135	0.0193	0.0394	0.000133	0.535	1	1.33	1.36	13.6
1 mbar =	0.001	0.00102	0.0102	0.0145	0.0295	0.0001	0.402	0.75	1	1.02	10.2
1 cm H <sub>2</sub> O =	0.00098	0.001	0.01	0.0142	0.029	9.81x10 <sup>-5</sup>	0.394	0.736	0.981	1	10
1 mmwc = 1 mm H <sub>2</sub> O =	0.000098	0.0001	0.001	0.00142	0.0029	9.81x10 <sup>-6</sup>	0.0394	0.0736	0.0981	0.1	1

\*The old unit kp/cm<sup>2</sup> is often referred to as "kilo per cm<sup>2</sup>", "kilos", "kg/cm<sup>2</sup>" or even "kilograms of pressure".

The correct unit should however be kp/cm<sup>2</sup> (kilo pond / square centimetre).

\*\* mwc and mmwc means meter water column and mm water column.

## 9. Conversion Table for Flow Units

**N.B.** A free physical unit converter software can be ordered from [reach.sweden@inficon.com](mailto:reach.sweden@inficon.com).

	g/a R <sub>134</sub>	mm <sup>3</sup> /s = µl/s	atm-cc/s = ml/s	mbar-l/s	Pa-m <sup>3</sup> /s
1 g/year of R <sub>134a</sub> =	1	8.0x10 <sup>-3</sup>	8.0x10 <sup>-6</sup>	7.9·10 <sup>-6</sup>	7.9x10 <sup>-7</sup>
1 mm <sup>3</sup> /s = 1 µl/s =	125	1	1.0x10 <sup>-3</sup>	9.87x10 <sup>-4</sup>	9.87x10 <sup>-5</sup>
1 atm-cc/s = 1 ml/s =	1.25x10 <sup>5</sup>	1000	1	0.987	0.0987
1 mbar-l/s =	1.27x10 <sup>5</sup>	1013	1.013	1	0.10
1 Pa-m <sup>3</sup> /s =	1.27x10 <sup>6</sup>	1.013x10 <sup>4</sup>	10.13	10	1

NOTE that it is not very common for pressure normalised flow units to be used. It is for instance common that cc/s is used in place of the more acceptable term, atm cc/s. It is, however, normally safe to assume that normalised units are implied.

## 10. Specifications

**Type:** Sintered metal powder.

**Connections:** *Inlet:* Compression connector for 6 x 4 mm and 1/4" x 5/32" tubing.  
ISO G1/8" internal behind connector.

*Outlet:* ISO G1/8" external.

*Purge valve:* Threaded plug to be opened with 2.5 mm Allen key. M5 internal behind plug. (Fits also male UNF10-32)

**Calibration methods:** Stated on the calibration certificated

**Traceability:** Traceable to UKAS, NAMAS, NIST, NMIJ, NPL, PTB etc through the Mutual Recognition Arrangement.

### Target flow for standard leaks:

Type	Part nr	Flow value	Flow unit	Gas	Upstream pressure (barg)	Downstream pressure
A	590-420	$5 \times 10^{-2} \pm 10\%$	atm ml/s	Air	1	1 atm
B	590-421	$5 \times 10^{-3} \pm 10\%$	atm ml/s	Air	1	1 atm
C	590-422	$5 \times 10^{-4} \pm 10\%$	atm ml/s	Air	1	1 atm