



GSM/GPRS/GPS Tracker **GV200G**

User Manual

TRACGV200GUM001

Revision: 1.01



<http://www.queclink.com>

sales@queclink.com

Document Title	GV200G User Manual
Version	1.01
Date	2012-07-23
Status	Release
Document Control ID	TRACGV200GUM001
Suitable Hardware Version	R101 or above

General Notes

Queclink offers this information as a service to its customers, to support application and engineering efforts that use the products designed by Queclink. The information provided is based upon requirements specifically provided to Queclink by the customers. Queclink has not undertaken any independent search for additional relevant information, including any information that may be in the customer's possession. Furthermore, system validation of this product designed by Queclink within a larger electronic system remains the responsibility of the customer or the customer's system integrator. All specifications supplied herein are subject to change.

Copyright

This document contains proprietary technical information which is the property of Queclink Limited., copying of this document and giving it to others and the using or communication of the contents thereof, are forbidden without express authority. Offenders are liable to the payment of damages. All rights reserved in the event of grant of a patent or the registration of a utility model or design. All specification supplied herein are subject to change without notice at any time.

Copyright © Shanghai Queclink Wireless Solutions Co., Ltd. 2012

Contents

Contents	2
Table Index.....	3
Figure Index	4
0. Revision History	5
1. Introduction.....	6
1.1. Reference.....	6
1.2. Terms and Abbreviations.....	6
2. Product Overview	7
2.1. Appearance.....	7
2.2. Parts List.....	8
3. Interface Description.....	9
3.1. SIM Card Interface.....	9
3.2. Antenna Interface	10
3.2.1. Install Antennas	10
3.2.2. GPS antenna specification.....	10
3.2.3. GSM antenna specification	11
3.3. User Interface	12
3.3.1. Interface Definition	12
3.3.2. Power Connection	13
3.3.3. 5V Output.....	14
3.3.4. Reset Key	14
3.3.5. Ignition Detect.....	15
3.3.6. Ignition Control.....	15
3.3.7. Electrical conditions for digital inputs	16
3.3.8. Digital Input without Interrupt	17
3.3.9. Digital Input with Interrupt	18
3.3.10. Analog Input.....	18
3.3.11. Digital Output.....	20
3.4. Indicator Light Description	22
3.5. Audio Interface.....	24
3.6. UART Interface	25
4. GV200G_RELAY_Cable.....	26

Table Index

TABLE 1: REFERENCE.....	6
TABLE 2: TERMS AND ABBREVIATIONS.....	6
TABLE 3: PART LIST	8
TABLE 4: GPS ANTENNA SPECIFICATION	10
TABLE 5: GSM ANTENNA SPECIFICATION	11
TABLE 6: THE DEFINITION OF 24 PIN CONNECTOR.....	12
TABLE 7: THE DESCRIPTION OF 24 PIN	13
TABLE 8: ELECTRICAL CONDITIONS OF IGNITION DETECT	15
TABLE 9: ELECTRICAL CONDITIONS OF IGNITION CONTROL	16
TABLE 10: ELECTRICAL CONDITIONS OF NEGATIVE TRIGGER DIGITAL INPUTS.....	16
TABLE 11: ELECTRICAL CONDITIONS OF POSITIVE TRIGGER DIGITAL INPUTS.....	17
TABLE 12: ELECTRICAL CONDITIONS OF DIGITAL OUTPUTS	20
TABLE 13: DESCRIPTION OF LEDS.....	23
TABLE 14: THE CHARACTERISTICS OF MICROPHONE	24
TABLE 15: THE CHARACTERISTICS OF SPEAKER.....	25

Figure Index

FIGURE 1: APPEARANCE OF GV200G	7
FIGURE 2: SIM CARD INTERFACE.....	9
FIGURE 3: SIM CARD INSTALLATION	9
FIGURE 4: THE ANTENNAS OF GV200G	10
FIGURE 5: THE SEQUENCE OF 24 PIN CONNECTOR.....	12
FIGURE 6: EXAMPLE OF POWER CONNECTION	14
FIGURE 7: THE KEY OF RESET.....	14
FIGURE 8: IGNITION DETECTION	15
FIGURE 9: EXAMPLE CONNECTION OF IGNITION CONTROL	16
FIGURE 10: EXAMPLE CONNECTION FOR NEGATIVE TRIGGER DIGITAL INPUTS	17
FIGURE 11: EXAMPLE CONNECTION FOR POSITIVE TRIGGER DIGITAL INPUTS	17
FIGURE 12: EXAMPLE CONNECTION OF PANIC BUTTON	18
FIGURE 13: AIN1 CONNECT TO NTC RESISTOR	19
FIGURE 14: AIN2/3 CONNECT TO CAPACITANCE-TYPE SENSOR	19
FIGURE 15: THE EXAMPLE CONNECTION TO DRIVE A LED	20
FIGURE 16: THE EXAMPLE CONNECTION TO DRIVE A RELAY	20
FIGURE 17: LEDS ON GV200G	22
FIGURE 18: EXAMPLE CONNECTION FOR AUDIO.....	24
FIGURE 19: THE CONNECTION OF UART1 WITH FEMALE DB-9	25
FIGURE 20: THE CONNECTION OF UART2 WITH EXTERNAL DEVICES.....	26
FIGURE 21: THE CONNECTION OF GV200G_RELAY_CABLE WITH EXTERNAL DEVICES..	26

0. Revision History

Revision	Date	Author	Description of change
1.00	2011-12-22	Leo LEI	Initial
1.01	2012-07-23	Leo LEI	1> Modify the introduction of chapter 1; 2> Modify the content of figure 9 and figure 16; 3> Add the description of the internal flyback diode in chapter 3.3.11; 4> Add Suitable Hardware Version.

1. Introduction

The GV200G is a powerful GPS Locator designed for vehicle tracking or assets tracking. With superior receiving sensitivity, fast TTFF (Time to First Fix) and Quad-Band GSM frequencies 850/900/1800/1900, its location can be monitored in real time or periodically tracked by a backend server or other specified terminals. The GV200G has multiple input/output interfaces which can be used for monitoring or controlling external devices. Based on the integrated @Track protocol, the GV200G can communicate with a backend server through the GPRS/GSM network to transfer reports of Emergency, Geo-fence boundary crossings, Lower Battery or scheduled GPS position along with many other useful functions. Users can also use GV200G to monitor the status of a vehicle and control the vehicle with its external relay output. System Integrators can easily setup their tracking systems based on the full-featured @Track protocol.

1.1. Reference

Table 1: Reference

SN	Document name	Remark
[1]	GV200G @Track Air Interface Protocol	The air protocol interface between GV200G and backend server.

1.2. Terms and Abbreviations

Table 2: Terms and abbreviations

Abbreviation	Description
AGND	Analog Ground
AIN	Analog Input
DIN	Digital Input
DOUT	Digital Output
GND	Ground
MIC	Microphone
RXD	Receive Data
TXD	Transmit Data
SPKN	Speaker Negative
SPKP	Speaker Positive

2. Product Overview

2.1. Appearance



Figure 1: Appearance of GV200G

2.2. Parts List

Table 3: Part List

Name	Picture
GV200G Locater	
User Cable	
GPS Antenna	
GSM Antenna	
12V DC power supply (Optional)	
USB-232 data cable (Optional)	
Uart Cable (Optional)	
Extend Cable (Optional)	

3. Interface Description

3.1. SIM Card Interface

To install the SIM card

Step 1: Press the yellow button on the right side of SIM card slot to eject the SIM card holder.

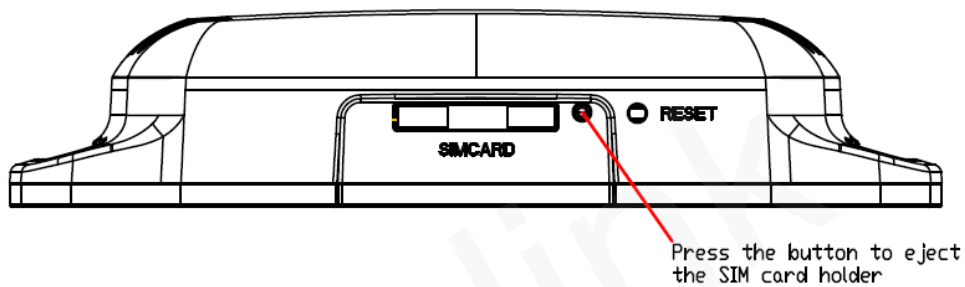

Figure 2: SIM Card Interface

Step 2: Put the SIM card on the SIM card holder.

Step 3: Install the SIM card holder to SIM card slot. Please pay attention to the direction.

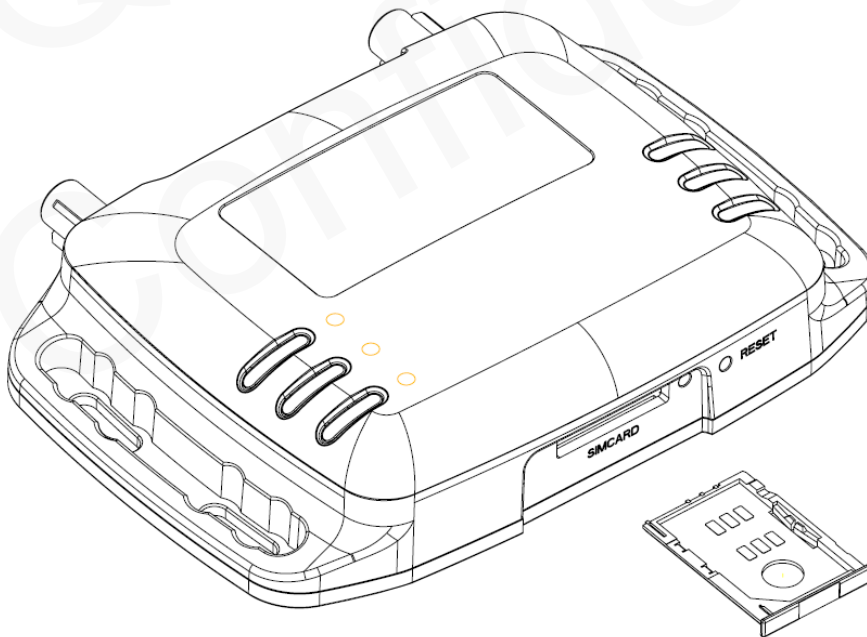

Figure 3: SIM Card Installation

3.2. Antenna Interface

3.2.1. Install Antennas

There are two Fakra antenna connectors on GV200G, the blue one for GPS and the purple one for GSM. Please find the GPS antenna and GSM antenna in package box. Install them to the correct Fakra connector as following.

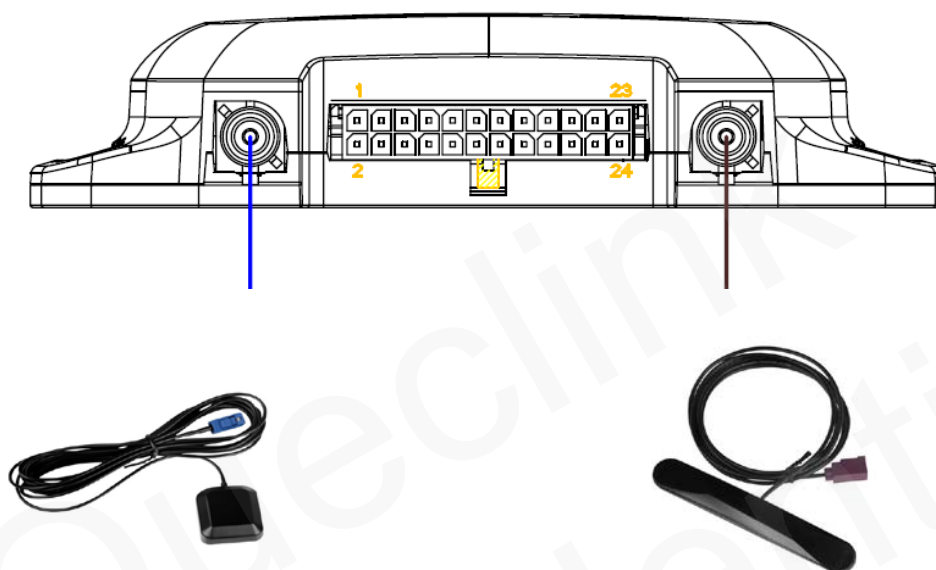

Figure 4: The Antennas of GV200G

3.2.2. GPS antenna specification

Table 4: GPS antenna specification

GPS antenna:	Frequency: 1575.42MHz
Bandwidth:	>5MHz
Beamwidth:	>120 deg
Supply voltage:	3.3V
Polarization:	RHCP
Gain:	Passive: 0dBi minimum Active: 15dB
Impedance:	50Ω
VSWR:	< 2
Noise figure:	< 3

3.2.3. GSM antenna specification

Table 5: GSM antenna specification

GSM antenna specification	
Frequency and bandwidth	GSM850: 824MHz to 894MHz EGSM900: 880MHz to 960MHz DCS1800: 1710MHz to 1885MHz PCS1900: 1850MHz to 1990MHz
Direction:	Omnidirection
Gain:	Passive: >0dBi
Impedance:	50Ω
VSWR:	<4
Efficient:	GSM850: >40% EGSM900: >40% DCS1800: >30% PCS1900: >30%

3.3. User Interface

3.3.1. Interface Definition

There is a 24 PIN connector on GV200G. It contains the interface of power, I/O, RS232, microphone, speaker, etc. The sequence and definition of the 24 PIN connector are showed in following figure:

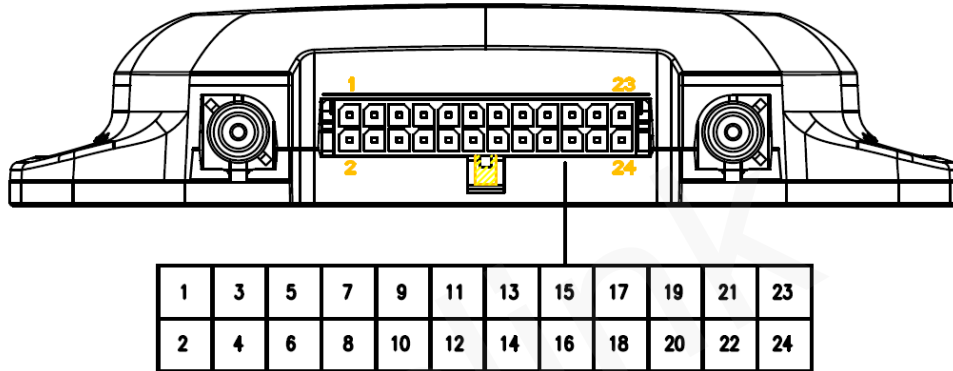

Figure 5: The sequence of 24 PIN connector

Table 6: The definition of 24 PIN connector

1	3	5	7	9	11	13	15	17	19	21	23
AGND	AIN1	AIN2	AIN3	RXD2	TXD2	DTR	RXD	TXD	VOUT	DOUT1	GND
2	4	6	8	10	12	14	16	18	20	22	24
MIC	SPKP	SPKN	DIN4	DIN3	DIN2	DIN1	DOUT4	GND	DOUT3	DOUT2	VIN

Table 7: The description of 24 PIN

Index	Color of User cable	Description	Comment
1	Black	Analog Ground	For microphone and analog inputs
2	Blue	Microphone Input	MIC+
3	Green	Analog Input 1 (Input range: 0 ~ 2.7V)	For resistance-type sensors
4	Blue	Speaker Output	Differential, Positive
5	Green	Analog Input 2	For capacitance-type sensors
6	Blue	Speaker Output	Differential, Negative
7	Green	Analog Input 3	For capacitance-type or resistance-type sensors
8	White	Digital Input 4	Negative Trigger
9	Orange	Receive Data (UART2, RS232)	Connect to TXD of external device
10	White	Digital Input 3	Positive Trigger, With interrupt
11	Orange/Gray	Transmit Data (UART2, RS232)	Connect to RXD of external device
12	White	Digital Input 2	Negative Trigger, with interrupt. Recommended for panic button
13	Orange/Brown	DTR	Data Terminal Ready. For waking up UART1 & UART2
14	White	Digital Input 1 (ACC Detect)	Positive Trigger, fixed for ignition detect
15	Orange	Receive Data (UART1, RS232)	Connect to TXD of external device
16	Yellow	Digital Output 4	Negative Trigger
17	Orange/Gray	Transmit Data (UART1, RS232)	Connect to RXD of external device
18	Black	Ground	For 5V output and UART
19	Purple	5V Output	VOUT
20	Yellow	Digital Output 3	Negative Trigger
21	Yellow	Digital Output 1	Negative Trigger
22	Yellow	Digital Output 2	Negative Trigger
23	Black	Ground	Power Ground
24	Red	Power (+8V ~ 32V)	Power (VIN)

3.3.2. Power Connection

PIN 24 is named as VIN which input voltage range is 8V to 32V DC and can be connected to vehicle's battery directly (12V or 24V DC).

Please install the power like following.

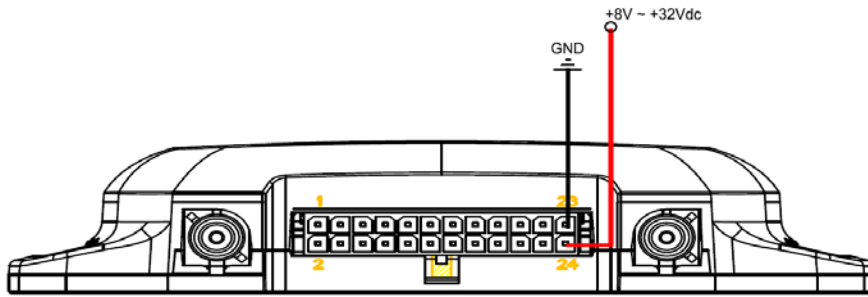

Figure 6: Example of power connection

3.3.3. 5V Output

PIN 19 is named as VOUT which can drive a controlled 5V output for user. Please note that if user wants to drive a 5V output, GV200G must be supplied by external power. In default, 5V output is disabled, user can use AT commend to enabled 5V output. The max drive current of VOUT is 0.25A.

3.3.4. Reset Key

There is a reset key on the right side of SIM Card interface. When the key is pressed, the device will reboot. Please note that reboot do not change any firmware parameter.

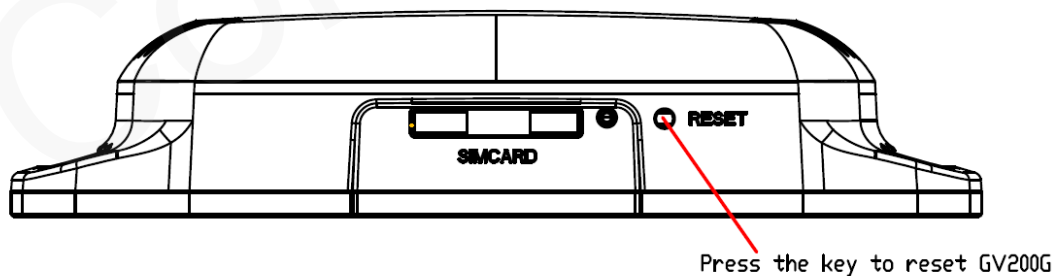

Figure 7: The key of reset

3.3.5. Ignition Detect

The PIN 14 is DIN1 (Positive trigger). Its electrical conditions are:

Table 8: Electrical conditions of ignition detect

Logical State	Electrical State
Active	5.0V to 32V
Inactive	0V to 3V or Open

It is strongly recommended to connect this pin to ignition key to support the power saving function when the vehicle is off.

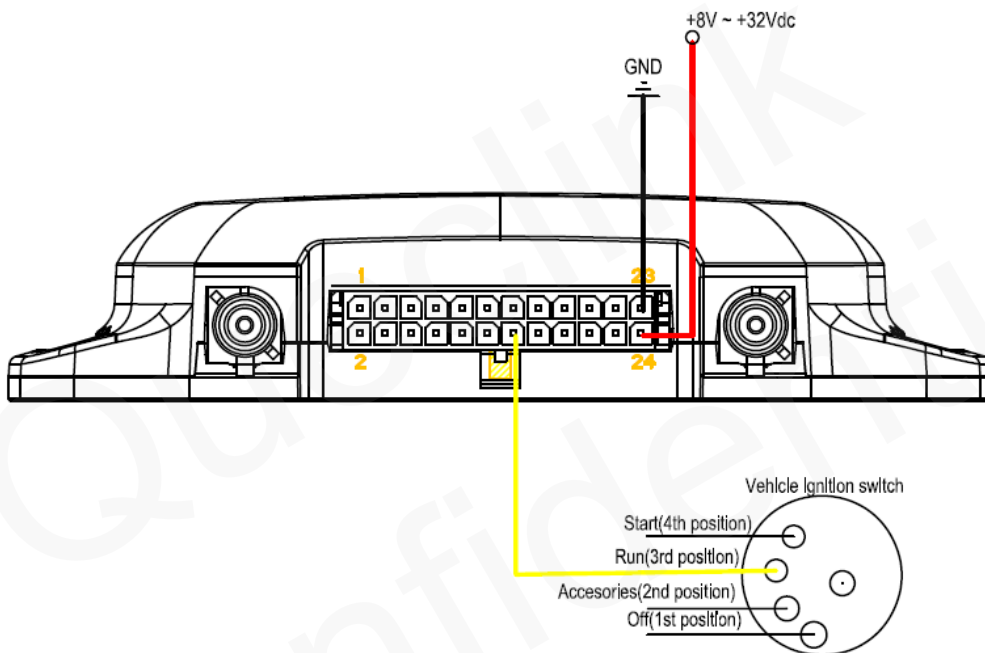

Figure 8: Ignition detection

Another easy way is to connect PIN14 to a power output in the fuse box of the vehicle which is only enabled after the vehicle is ignition on. For example: the power output for radio FM.

3.3.6. Ignition Control

DOUT1/2/3/4 can be used to control ignition key. They are Open-Drain type with no internal pull-up resistor which also be used to control a relay. It means that the user has to connect a pull-up resistor or a relay coil between the DOUT1/2/3/4 pin and any positive voltage (32V max.) to generate a correct output. The DOUT1/2/3/4 pin can drive a continuous current of 0.2A.

The electrical conditions of it are:

Table 9: Electrical conditions of ignition control

Logical State	Electrical State
Enable	<1.5V, drive current is 0.2A
Disable	Open or the pull-up voltage (max 32V)

User can use this pin to control a relay output. An example to control the ignition key is showed in following figure. Please refer to chapter 3.3.11 for the detail information on how to drive a relay with digital output.

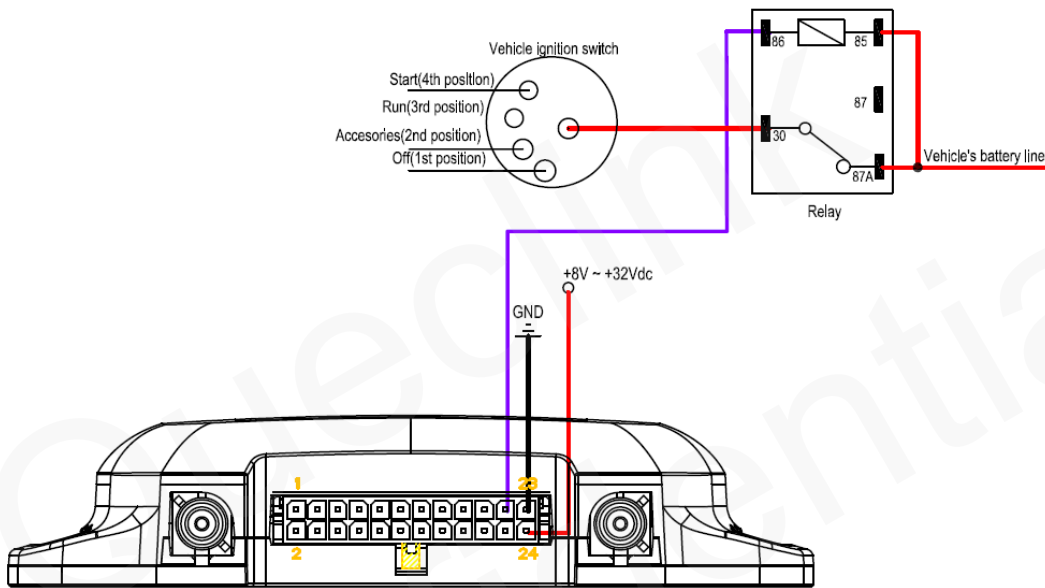

Figure 9: Example connection of ignition control

3.3.7. Electrical conditions for digital inputs

For negative trigger inputs the electrical conditions are:

Table 10: Electrical conditions of negative trigger digital inputs

Logical State	Electrical State
Active	0V to 0.8V
Inactive	1.7V to 32V or Open

The example connection is showed as follow:

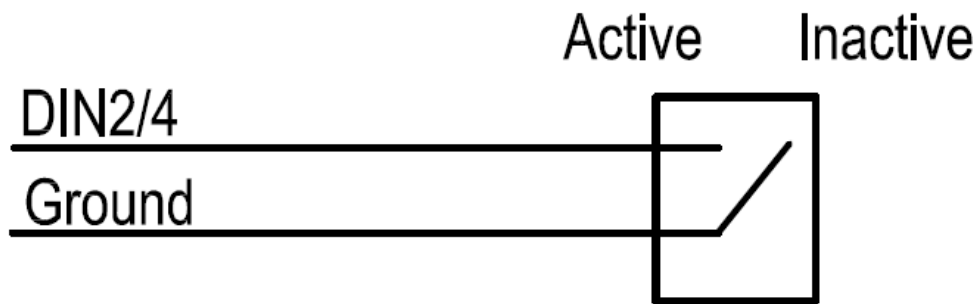

Figure 10: Example connection for negative Trigger digital inputs

For positive trigger inputs the electrical conditions are:

Table 11: Electrical conditions of positive trigger digital inputs

Logical State	Electrical State
Active	5.0V to 32V
Inactive	0V to 3V or Open

The example connection is showed as follow:

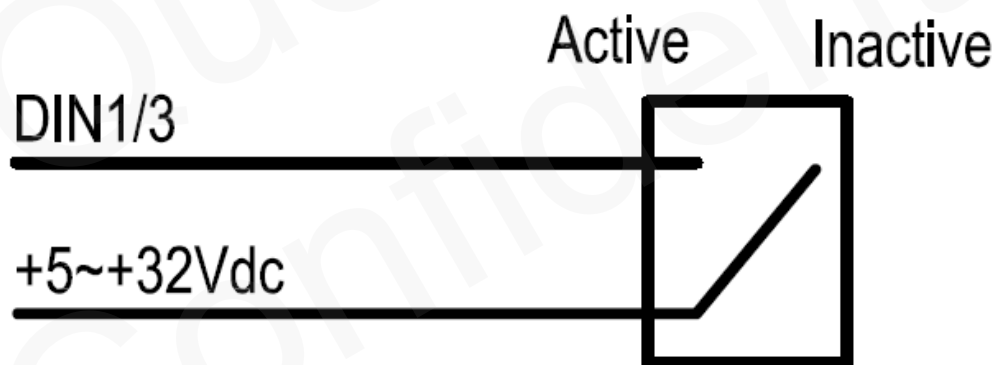

Figure 11: Example connection for positive trigger digital inputs

3.3.8. Digital Input without Interrupt

The DIN1 and DIN4 are digital inputs which do not have interrupt. DIN1 is positive trigger and DIN4 is negative trigger. The sample rate for this digital input is 2 to 24 seconds. Please note the high sample rate will also result in high power consumption.

3.3.9. Digital Input with Interrupt

DIN2 and DIN3 are digital inputs which have interrupt. DIN2 is negative trigger and DIN3 is positive trigger.

The example connections are same as showed in chapter 3.3.7.

DIN2 is also recommended to support panic button function and the connection is showed as follow.

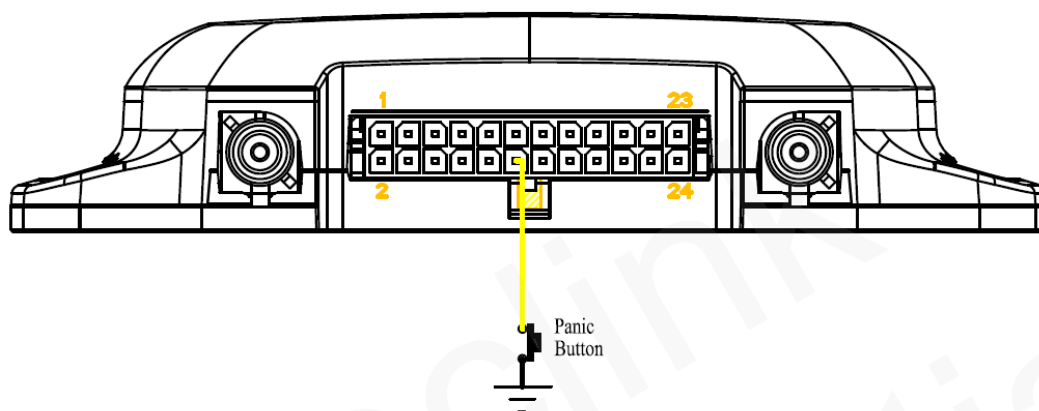

Figure 12: Example connection of panic button

3.3.10. Analog Input

The PIN 3/5/7 are used for analog to digital converter. GV200G can support different type sensors such as resistance-type and capacitance-type due to the differences between the three analog inputs. Please note it is an average value based on the sample rate from 2 to 24 seconds, which means the burst on voltage input may not be detected.

3.3.10.1. Resistance-type Sensor

AIN1 (PIN 3) is designed to support some resistance-type sensors and there is an internal pull-up resistor (100K Ohm) on its channel. Due to the internal pull-up resistor, user can connect resistance-type sensors directly between analog inputs and AGND. The follow figure is the example connection of AIN1 with NTC resistor. The recommended value of NTC resistor is 100K@25°C.

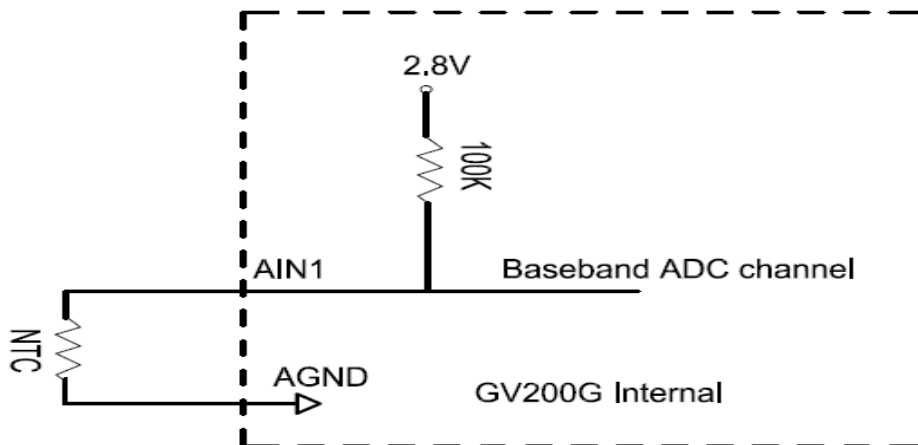

Figure 13: AIN1 connect to NTC resistor

3.3.10.2. Capacitance-type Sensor

AIN2 (PIN 5) and AIN3 (PIN 7) are designed to support capacitance-type sensors. In default GV200G only support capacitance-type sensors which voltage range is 0 ~ 2.7V. If user wants to use the capacitance-type sensors which voltage range is out of 0 ~ 2.7V, a level transfer board must be used between capacitance-type sensors and GV200G. The follow figure is the example connection of AIN2/3 with capacitance-type sensors.

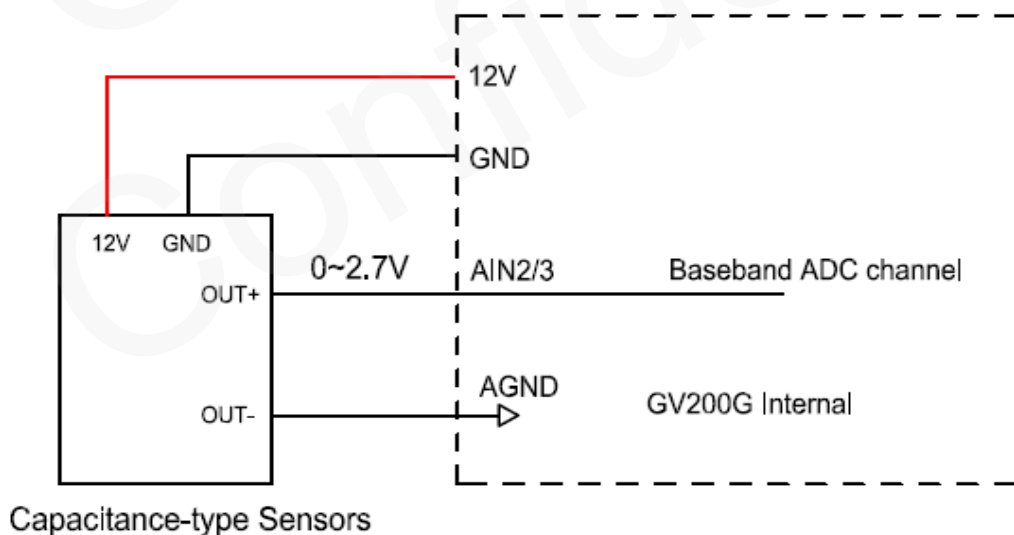

Figure 14: AIN2/3 connect to capacitance-type sensor

User also can connect a power source directly to AIN2/3, the voltage limitation is same as capacitance-type sensor.

3.3.11. Digital Output

The outputs are Open-Drain type with no internal pull-up resistor which also be used to control a relay. It means that the user has to connect a pull-up resistor or a relay coil between the output pin and any positive voltage (32V max.) to generate a correct output. Each output can drive a continuous current of 0.2A.

The electrical conditions are:

Table 12: Electrical conditions of digital outputs

Logical State	Electrical State
Enable	<1.5V, drive current is 0.2A
Disable	Open or the pull-up voltage (max 32V)

Digital outputs are used for cutting/restoring GND. The example connections are:

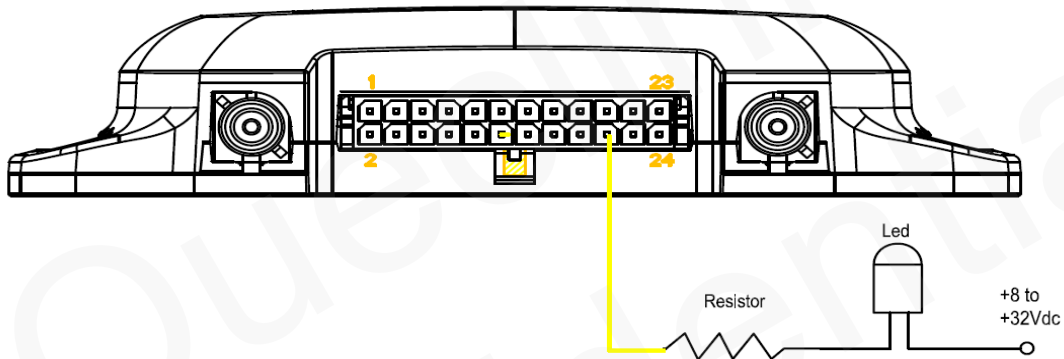

Figure 15: The example connection to drive a LED

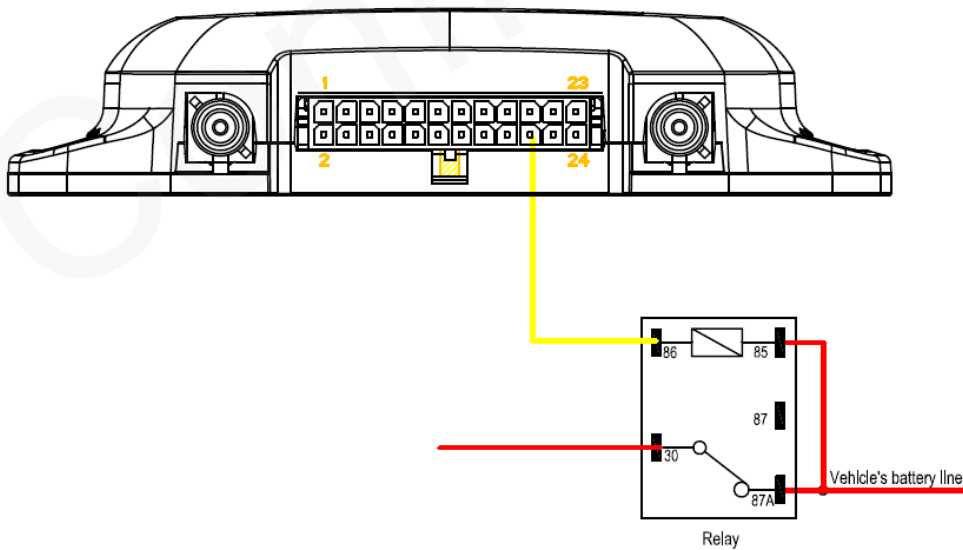

Figure 16: The example connection to drive a relay

Note: All outputs are internally pulled up to PWR pin by a diode. So no external flyback diode is needed when the output is connected to an inductive load.

Queclink
Confidential

3.4. Indicator Light Description

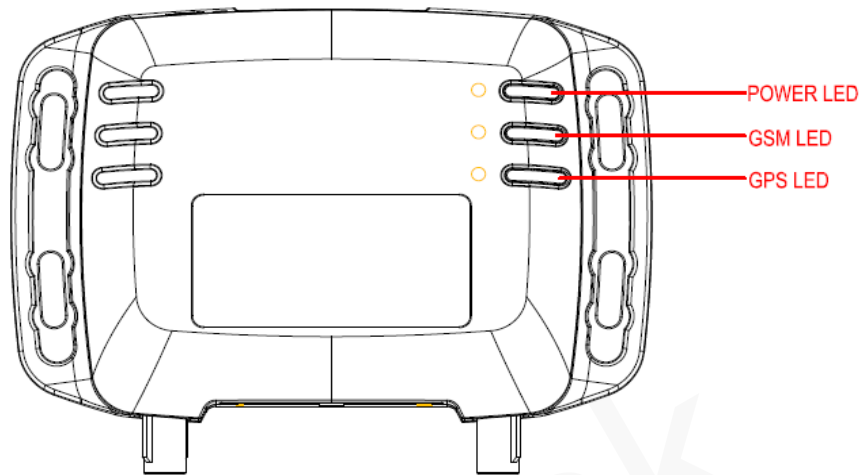

Figure 17: LEDs on GV200G

There are three LEDs in GV200G, the description as follow.

Table 13: Description of LEDs

Light	Case	State
GPS LED	If LED switch is set to off by AT+GTCFG, GPS LED will be off all the time after it has worked for 30 minutes maximum from GV200G was powered on. In this case, cases for GPS LED listed below will be ignored.	Always Off
	GPS LED will be off if GPS chip is closed.	Off
	Checksum of NEMA packet from GPS chip is invalid.	Slow flashing
	There is no data output from GPS chip when it is working.	
	GPS chip is trying to get valid GPS info.	Fast flashing
	GPS chip has been getting valid GPS info.	On
PWR LED	If LED switch is set to off by AT+GTCFG, PWR LED will be off all the time after it has worked for 30 minutes maximum from GV200G was powered on. In this case, cases for PWR LED listed below will be ignored.	Always Off
	Backup battery is enabled and its voltage is not low if external power supply is cut.	Off
	Backup battery is enabled and its voltage is low if external power supply is cut.	Slow flashing
	Backup battery is enabled and it is in charging by external power supply.	Fast flashing
	Backup battery is enabled and it is fully charged by external power supply.	On
	Backup battery is disabled and external power supply is connected.	
GSM LED	GV200G is in searching GSM network state.	Fast flashing
	GV200G has been registered to GSM network.	Slow flashing
	SIM card inserted to GV200G need pin code to unlock.	On

3.5. Audio Interface

There is a differential output for speaker and a signal-ended microphone on GV200G. Please note that the PIN 1 is analog ground and should not be used as a power ground. GV200G has an audio amplifier internally, so it can drive a louder speaker directly. It is recommended to connect an 8 Ohm speaker to speaker interface, and an electret microphone is also recommended.

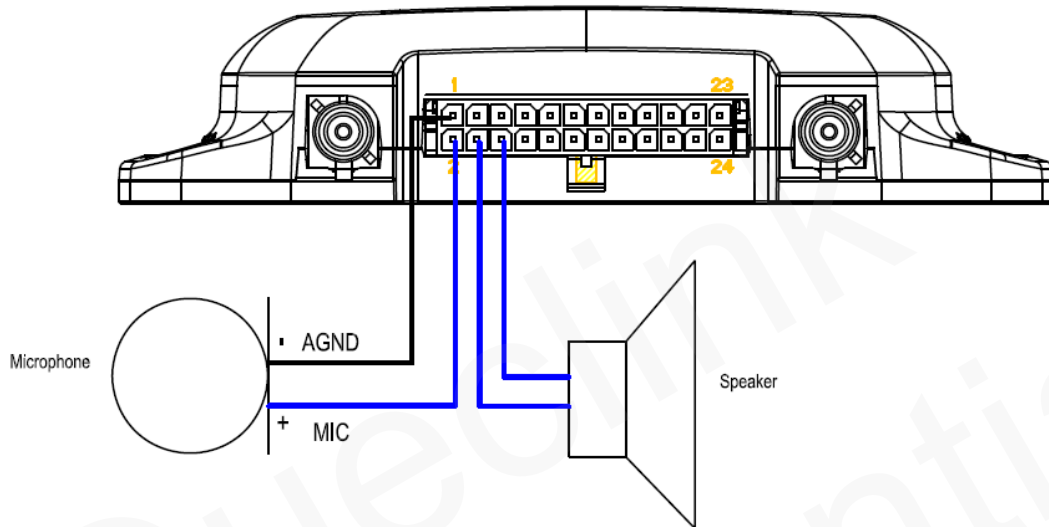

Figure 18: Example connection for audio

Microphone input characteristics

Table 14: The characteristics of Microphone

Parameter	Min	Typ	Max	Unit
Working Voltage	1.0	1.5	2.0	V
Working Current	200		500	uA
External Microphone Load Resistance		2.2		k Ohm

Please note there are some recommendations about microphone:

- 1: Use an electret microphone with a sensitivity of $-42\pm 3\text{dB/Pa}$ @ 2V (not less than $-44\pm 3\text{dB}$) and impedance of $2.2\text{k}\Omega$.
- 2: Two filter capacitors (10pF (0603) and 33pF (0603)) are recommended to build into microphone by vendor. These two capacitors could largely suppress coupling TDD noise from RF interference.
- 3: MIC /AGND should be a couple of differential traces, not be close to power supply signals.

Speaker output characteristics

Table 15: The Characteristics of Speaker

Parameter	Conditions	Min	Typ	Max	Unit
Load Resistance			8		Ohm
Differential output level (peak to peak)		0		8.8	V
Rms Output Power	$V_p = 4.4V$, $R_L = 8\text{ OHM}$ $THD + N < 0.1\%$			900	mW

3.6. UART Interface

There are two UART interfaces on GV200G which are named as UART1 and UART2. UART1 is used for configuration and firmware downloading. UART2 is used to communicate with external devices like CAN Bus module and RFID reader. PIN 13 is a control signal which is named as data terminal ready (DTR). When the GV200G is sleeping, a high level on DTR will wake up UARTs of GV200G.

Please note the UART interfaces are all RS232 level. For RS232 level, valid signals are plus or minus 3V to 15V and the -3V to +3V is not a valid level. 3V to 15V correspond with logic 0 of TTL level, -3V to -15V correspond with logic 1.

The example connections of UART1 with female DB-9 and UART2 with external devices are showed as follow.

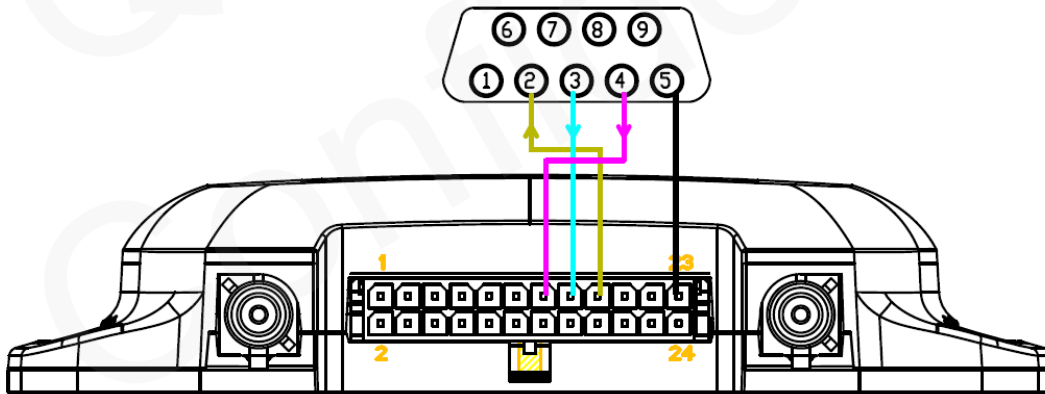

Figure 19: The connection of UART1 with female DB-9

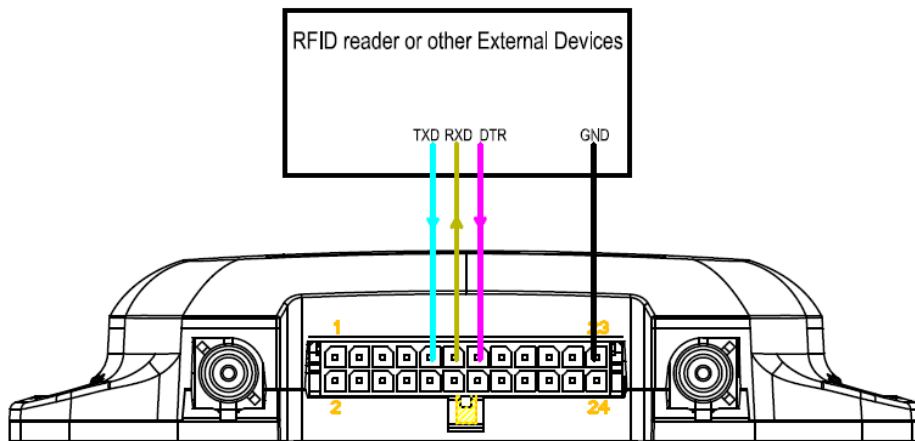

Figure 20: The connection of UART2 with external devices

4. GV200G_RELAY_Cable

GV200G_RELAY_CABLE is an assembled harness cable which contains a cut relay output and some digital input and outputs. It can easily help the user to install the GV200G in vehicle with engine cutting function. The diagram of the GV200G_RELAY_CABLE is showed in following:

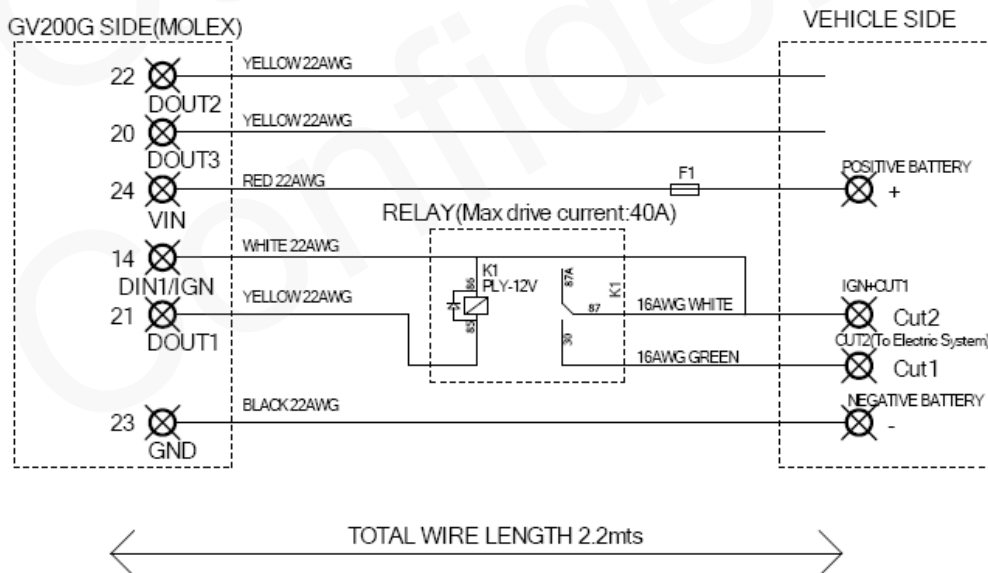

Figure 21: The connection of GV200G_RELAY_CABLE with external devices