

## 后续

本说明书中的资料均以最新产品为依据，由于改进或其他变化，本说明书的描述可能与实际情况稍有出入，我公司将保留随时修改的权利，修改之处恕难一一相告。

本说明书版权属于温州山度仪器有限公司。未经许可任何单位及个人不得以任何形式和手段复制或抄袭本说明书的局部或全部内容。

Data of the manual is equally had newest product as evidence, because of improvement or other change, description of manual may differ from practical situation. Our company will reserve the right corrected at any moment, it is difficult to list the corrected place one by one.

Copyright of manual belongs to WENZHOU SUNDOO Instrument Co., Ltd. Any unit and individual can't copy or plagiarize the part or full content.

制造商：温州山度仪器有限公司

**MANUFACTURER: WENZHOU SUNDOO INSTRUMENTS CO.,LTD**

地址：温州高新技术产业园区10区E幢

Add: Building E, No.10 High-tech Industrial Zone Wenzhou China

Zip: 325013

Tel: +86 577 88609903 88609730 Fax: +86 577 88390155

Http://www.sundoo.com E-mail:sundoo@sundoo.com

Ver:1.01 Con:20110121

SVM-208  
使用说明书

视频数码显微镜

**VIDEO DIGITAL MICROSCOPE**

温州山度仪器有限公司  
WENZHOU SUNDOO INSTRUMENT CO., LTD.

背面  
**Back View**

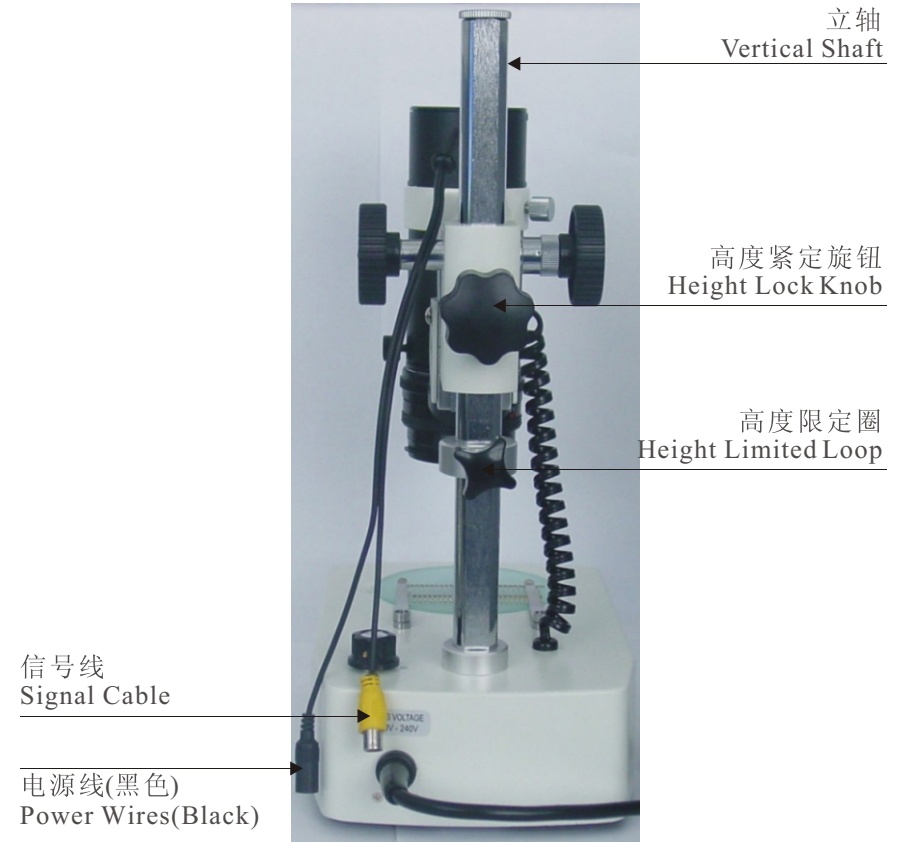

正面  
Front View

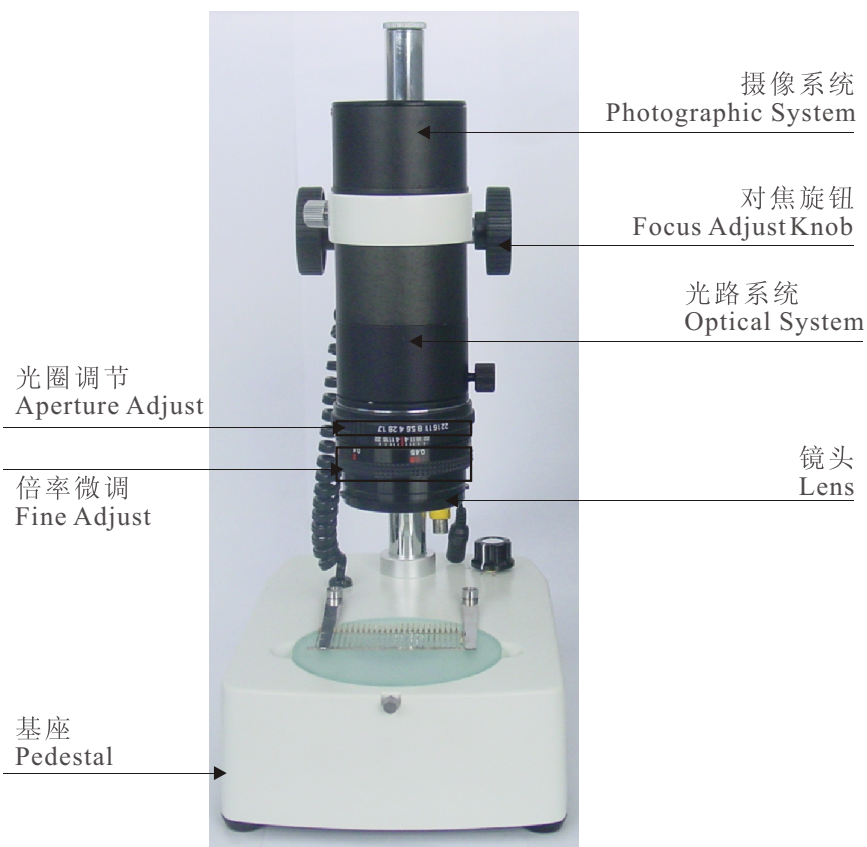

非常感谢购买SVM-208视频数码显微镜。

SVM-208系列视频数码显微镜是针对现代制造业的需要，为产品质量检测而研发。运用消杂光大景深技术，并采用优质CCD，能高清晰度成像。有上下两种光源，可在各种作业环境下工作。视频可直接输出观测，使观测人员真正远离直视疲劳。普及型价格定位，操作简单而简单，提高工作效率。配合配套软件可实现长/宽度、圆半径、角度等测量。在一定程度上可替代投影仪、工具显微镜和影像测量仪。

Thank you for your purchasing SVM-208 Video Digital Microscope. SVM-208 Video Digital Microscope is researched and designed for quality control of modern manufacture. It is applied with the unique technology of eliminating interferential beam and wide range depth of field meanwhile, It is adapted Hi-quality SONY CCD camera, Therefore it can provide the Hi-definite picture. Moreover the unit is equipped double illumination. The upper illumination is applied in surface inspection. And the background illumination is applied in profile inspection. The unit can be used in various inspected field. The microscope can be directly connected with video monitor, which helps inspector to avoid optic tiredness and reading from scale. Our microscope makes more efficiency and less, reduces working time. The optional mythologic software can be applied in the measurements of length & width, radius, angle, and so on. In some aspect, the microscope can replace profile projector, toolmaker measuring microscope and optical image measuring system.

## 规格参数

**Specification**

外型尺寸 Dimension	260×380×380 mm
净重量 N.W.	3.5kg
解析度 Resolution	0.5 Micron
精度 Accuracy	10 Micron
连续变倍 Continuously Zoom	15x-45x/20x-80x
工作距离 Working Distance	300mm
最大单帧视场范围 Field Of View	11×15mm
功率 Power Consumption	5w
显示方式 Display	监视器/电脑/液晶屏/电视机 Monitor/Computer/LCD/TV
计算机接口方式 Computer Mode	视频采集卡 Image Card
信号传输 Signal Transfer	视频信号线 AV Magic Card
电源供应 AC Power	220V/50Hz

**Packing List**

Number	Parts Name	Quantity
1	Pedestal( With two lightsource)	1
2	Sony CCD Image Lens + Optic Lens	1
3	Av Signal Cable	1
4	White& Black Background Board	1
5	12V Adaptor(supply the CCD power)	1
6	Dustproof Cover	1
7	User' Manual	1
8	Qualification certificate	1

**目 录**

产品概述.....2

外形结构.....2

规格参数.....2

注意事项.....2

操作实例.....3

配件选择.....4

产品保养.....5

包装清单.....6

## 产品概述

SVM-208系列视频数码显微镜是针对现代制造业的需要，为产品质量检测而研发。运用消杂光大景深技术，并采用优质CCD，能高清晰度成像。有上下两种光源，可在各种作业环境下工作。视频可直接输出观测，使观测人员真正远离直视疲劳。普及型价格定位，操作轻松简单，大大提高工作效率，节约人工成本，增加利润。配合配套软件可实现长度、宽度、圆半径、角度等测量。在一定程度上可替代投影仪、工具显微镜和影像测量仪。

本产品广泛应用于电子、弹簧、螺丝、模具、粉末冶金、精密机械、珠宝钟表、饰品、指纹、票证识别、印刷、光纤、手机维修、考古、技术监督等领域。

- 1、SONY高清晰度CCD;
- 2、超大工作平台;
- 3、超高工作距离(300mm);
- 4、背光、底光双光源;
- 5、AV视频输出。

## 外形结构（见页14、15）

## 规格参数（见页13）

## 注意事项

- 1、请不要随便拆卸本手册所提及的可拆卸部件之外的任何部件，自行拆卸容易触电或损坏仪器，如发现仪器有故障，请找有经验的专业修理人员修理，或直接与厂家联系。
- 2、显微镜是一种精密仪器，操作应谨慎，强烈震动和硬性操作都会导致仪器的严重损坏。
- 3、为了安全，本机备有三脚地线插头，如果您无此种插座，请安装，切勿使用任何适配插头以致降低其安全功能。
- 4、显微镜底座上标有额定输入电压值，注意当地供电电压必须与其

The Measuring Software can provide measuring function, which can measure width, radii, diameter, distance between two lines and angle.  
Connecting Step:

Please insert the Video Card into the PCI connector, install Video Card's drive program and measuring program. Insert the AV plug into the CCD output connector, connect another AV terminal with input connector of VAG.

- (3) The Motive Platform  
Installing the motive platform on the working-stage makes the measured objects move smoothly. There is a accessory scale on the motive platform, which has a resolution of 0.02mm.

Note: Above accessories should be purchased additionally.

## Maintenance

- (2) Lens Cleaning
  - 1) Use the soft brush or cotton cloth to clear the dust.
  - 2) Use the alcohol logged cotton clothe or paper to clear the oil on the lens.
  - 3) Do not use the methylbenzene.
  - 4) The alcohol is flammable, pay more attention when turn on or turn off the power.
- (3) How to stock  
If the microscope is not used, please cover it with dustproof cover and place it in a dry place.
- (4) Examination  
To keep the instrument in good condition, please examine it regularly.

- (5) Height adjust  
The higher you adjust, the lower times you choice, vice versa.



- (6) Local limitation  
Choice the height location you need, lathe this button to local the limitation of the height.



- (7) Times Change  
Loose the button, move the lens up and down. Choice the suitable times and lock it. Up moving reduce the megascopic times, down moving increase the megascopic times.



- (8) Reset Focus  
Adjust this button till the picture is clear.

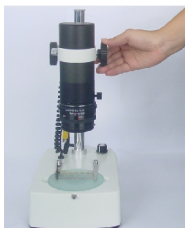

### Optional Accessories

- (1) AV/VGA, XGA- transfercard + CRT indicator  
The XGA-transfer card can provide hi-definition image, display on CRT, without flash and the picture is bright and flamboyant .  
Connecting Step:  
1) Attach the power, connect the CRT's signal plus with the transfer card's connector.  
2) Insert MMI signal provide with the instrument into the reciprocal connector on the transfer card, attach AV cable with Photographic lens' output connector, insert another AV terminal into the connector on the yellow MMI cable.  
(2) Monitor, Computer, Video Card, Measuring Software

相符。显微镜在非额定电压条件下使用将会严重损坏。

- 5、清洁本机之前，请从交流电源插座拔出本机的电源插头，勿使用液体或喷雾清洁剂擦拭电源部分。
- 6、在搬动显微镜前，要关闭电源开关。
- 7、工作环境要求：0℃-40℃。最大相对湿度：<80%。
- 8、勿将显微镜置于有粉尘的环境之中，应平放在无震动的地方。

### 操作实例

1. 将机身电源插头插入电源插座



2. 将配送AV信号线插入显微镜信号线输入口

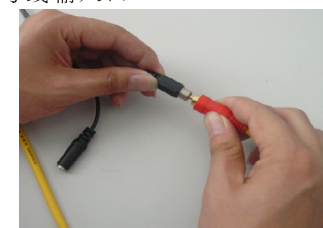

3. 将12V电源适配器的电源输出头插入显微镜电源输入口

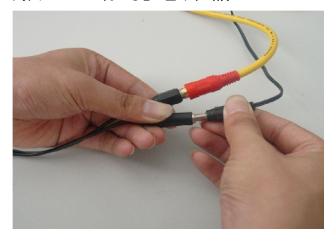

4. 将12V电源适配器插入电源插座



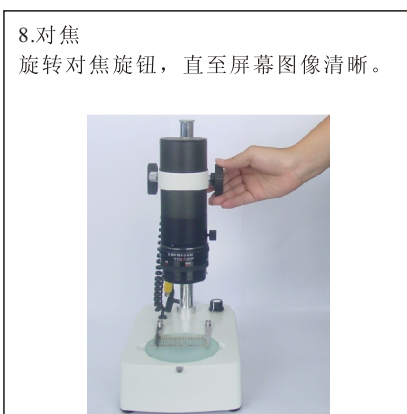

### 配件选择

#### 1、AV/VGA、XGA转换器+CRT显示器

采用此转换器可获得最高1024×768×75 Hz高质量图像，并在CRT上显示，无闪烁，色彩明亮艳丽。连接方法如下：

- (1)接通转换器电源，将CRT信号线插头和转换器上的母插头连接；
- (2)将转换器配套MMI线插入转换器相应接口，再将AV连接线一头插入摄像头AV输出接口，另一头插入MMI线引出的黄色接口，其它插头空闲。

will cause the damage of the machine.

3. You should use the special plus the machine need to make sure of your safety.
4. There is a rate input voltage on plinth, please use the proper voltage. Operation in the wrong voltage will damaged the microscope badly.
5. Before cleaning the machine, please cut down the plug. do not pour the fluid into the machine.
6. Before moving the machine, please turn off the mains.
7. Working Temperature: 0°C-40°C. The max relative humidity: <80%.
8. Avoid putting the machine in a dusty environment. should place the microscope in a non-shocking place

### Operation

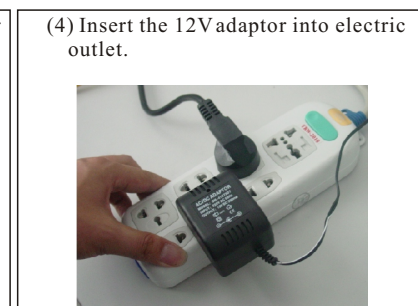
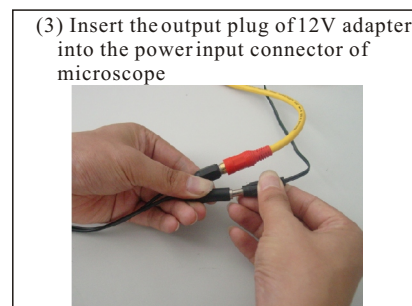
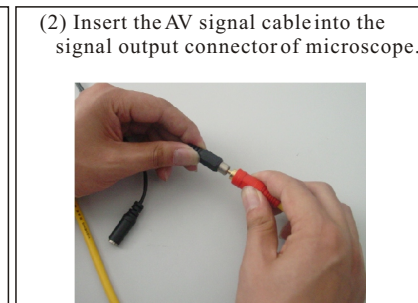
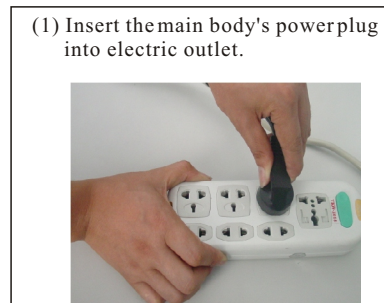

Finally, Connect another terminal of the AV signal cable with a monitor.



## Function

SVM-208 family of video digital microscope is researched and designed for quality control of modern manufacture. It is applied with the unique technology of eliminating interferential beam and wide range depth of field meanwhile. It is adapted Hi-quality SONY CCD camera, Therefore it can be provided the Hi-definite picture. Moreover the unit is equipped double illumination. The upper illumination is applied in surface inspection and the background illumination is applied in profile inspection. The unit can be used in various inspected field. The microscope can be directly connected with video monitor, which helps inspector to avoid optic tiredness and reading from scale. Our microscope makes more efficiency and less, reduces working time, and increases the profit. The optional metro logic software can be applied in the measurements of length & width, radius, angle, and so on. In some aspect, the microscope can replace profile projector, toolmaker measuring microscope and optical image measuring system.

The microscope is widely used in electric industry, spring, screw, die & mould manufacture, precious machinery, powder Metallurgy, jewel & clock, decoration industry, optic fibre industry, Quality Control Bureau, and so on.

SONY Hi-definition CCD Camera.

OverLarge Stage Version.

Sur-high Working Distance.

Upper and Background Illuminatio.

Video Signal Output.

## Structure(view Page 14 and 15)

## Specification(view Page 13)

## Attention

1. Do not dismantle any part that beyond what we had said in this brochure dismantle by yourself easily be hurt or damage the machine. If there is something wrong with your machine, please send for a repair man or contact with our company directly.
2. You should manage the instrument carefully, the fierce force and operation

## 2、显示器+电脑主机+视频采集卡+测量软件

使用测量软件可获得显微测量功能，可进行长度、宽度、圆半径/直径、线间距，线间角度等测量。连接方法如下：

将视频采集卡插在电脑主机PCI插槽上，并安装视频采集卡驱动程序和选配件测量软件。然后将AV连接线一头插入摄像头AV输出接口，另一头插入视频采集卡AV输入口。

## 3、移动平台

在工作台上增加移动平台，测量时使被测件移动更加平稳，移动平台上附带0.02mm分度的标尺。

## 产品保养

### 1、镜头清洁

(1)柔软的刷子或软棉布清洁灰尘。

(2)更多的较顽固的污迹如指纹、油脂等，可以用干净的软棉布，镜头纸或纱布蘸上无水酒精（纯酒精）轻轻地擦试。

(3)不要用二甲笨清洗。

(4)纯酒精易燃烧，再将电源开关打开或关闭时特别要当心着火。

### 2、显微镜的放置

显微镜不用时，请用塑料罩盖好，并贮放在干燥的地方。

### 3、定期检查

为保持显微镜的性能，建议进行定期检查。

**包装清单**

编号	名称	数量
1	机座(带上下光源)	1
2	CCD摄像头+镜头	1
3	Av信号线	1
4	黑白背景板	1
5	12V适配器(CCD供电用)	1
6	防尘罩	1
7	使用说明书	1
8	合格证及保修单	1

**CONTENTS**

Function.....8  
 Structure.....8  
 Specification.....8  
 Attention.....8  
 Operation.....9  
 Optional Accessories.....10  
 Maintenance.....11  
 Packing List.....12