

# HIGH VOLTAGE A.C. PROXIMITY DETECTOR HI-PROX

---

---



## INSTRUCTION MANUAL

<b>INDEX</b>	<b>PAGE</b>
Safety Rules.....	1
General Description.....	2
Low Voltage Testing.....	3
Front Panel Layout.....	4
Preparation for Use.....	5
Checking and Proofing the Tester.....	5
Typical Uses.....	6
Broken Wires in Cables .....	6
High Voltage Testing.....	7-8
Limitations of the Hi-Prox .....	9
Changing Batteries .....	10
Limited Warranty.....	11



**Caution, risk of electric shock.**



**Caution, refer to the user manual.**

## Safety Rules

The Hi-Prox has been designed with safety in mind. However, no design can completely protect against incorrect use.

**Electrical circuits are dangerous and lethal through lack of caution or poor safety practice. The following rules should reduce the danger:**

Read the user manual carefully and completely before using the tester. Fully understand the instructions before using this product. Follow the instructions for every test. Take all the necessary precautions. Do not exceed the limits of this instrument.

The Hi-Prox must never be in physical contact with any conductor higher than 1kV. This is a proximity detector, not a detector which works by contact.

Always use a fiber glass rod or any authorized stick.

A high voltage test is carried out with the tester attached to an operating stick, sometimes called "links stick".

Verify the rotary switch setting before measuring. Make sure it is on the correct setting for your application.

Always check that the Hi-Prox is working before and after the test.

Do not touch any exposed wiring, connections, or other "live" parts of an electrical circuit.

**This instrument should only be used by a competent, suitably trained person who understands this test procedure fully. Personnel working with high voltage should be trained regularly.**

## General Description

The **Hi-Prox** consists of an internal pickup sensor plate, a rotary switch as sensitivity selector, a sound annunciator (high pitch, high power buzzer), a visual indicator (high bright LEDs), and three "C" size batteries.

The Hi-Prox detects AC voltages using the sensor plate. The sensor plate collects part of the radiated electric field (V/M). The electric field is seen by the internal circuitry and triggers the input of a CMOS integrated circuit.

The integrated circuit charges a capacitor via a diode. Once that capacitor reaches a certain level, the buzzer and LEDs annunciator are turned "ON".

The trigger level is fixed (CMOS logical level change). The "self-test" inserts a voltage on the sensor plate, just like if the sensor would pick up a voltage. The Hi-Prox allows identification of AC voltages from 240Vac to 220kVac.

The enclosure is made out of industrial grade polyurethane.

The enclosure can be attached to a link stick. The small cylinder part of the Hi-Prox fits into most link stick adaptors.

## Low Voltage Testing

The Hi-Prox works by proximity. Physical contact with electrical conductors is not necessary when testing for live lines. Its sensor senses the radiated field which surrounds live conductors. It is recommended not to touch high voltage wires with the Hi-Prox.

Radiated field strength increases with voltage and decreases quickly with distance or earth shielding. The radiated field from a cable of closely bunched conductors supplied by three phase power, tends to cancel (See **"Limitations of the Hi-Prox"** on page 9 ).

Detecting distance of a 250Vac single live wire is about 10 cm and with a bunched neutral and earth cable, as seen in a flexible cable, the distance is reduced to 5 cm.



## Front Panel Layout

OFF	- Turn the pick-up sensor off
Self-Test	- Check if the entire circuitry is working
240Vac	- 240Vac selection
3.3kV	- 3.3kVac selection
6.6kV	- 6.6kVac selection
11kV	- 11kVac selection
22kV	- 22kVac selection
33kV	- 33kVac selection
66kV	- 66kVac selection
110kV	- 110kVac selection
220kV	- 220kVac selection
Buzzer	- High noise level buzzer
LEDs	- High bright low current LEDs
Battery Holder	

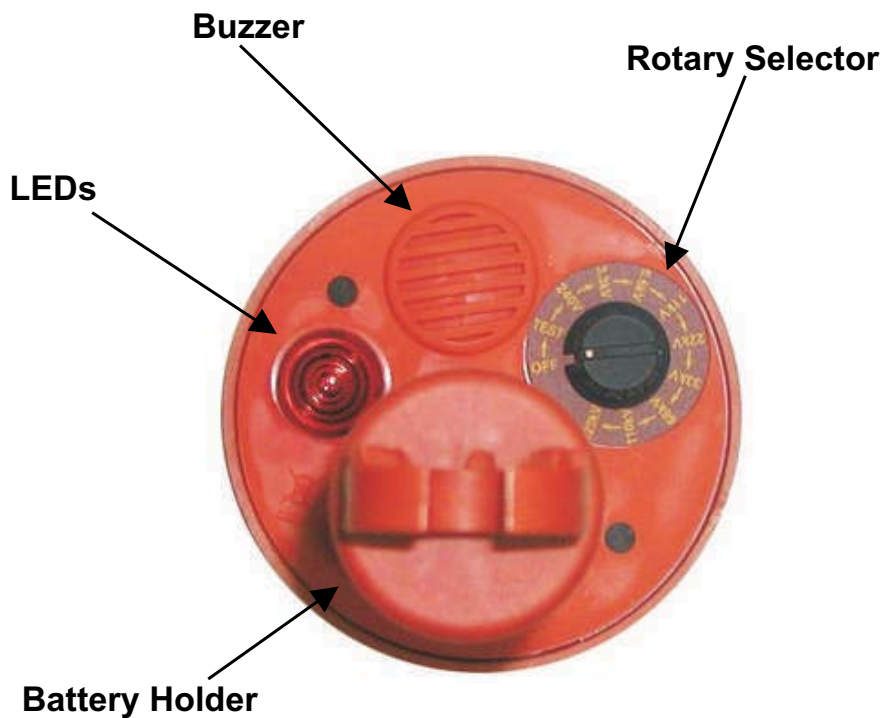

## Preparation for Use

When unpacked, the tester should be inspected for any visible signs of damage, and the preliminary checks described in the user manual should be performed to ensure that it is operating correctly. If there is any sign of damage, or if the instrument does not operate correctly, return it to your nearest supplier.

This instrument is powered by three "C" type batteries.

## Checking And Proofing The Tester

Switch the sensitivity to "SELF-TEST". The buzzer of the Hi-Prox should beep and the LEDs should light.

This indicates that the Hi-Prox is operational.

Verify the working of this unit by selecting 240Vac and place the dome against a low voltage live conductor or rub the dome with a cloth or against an item of clothing as this generates a static DC which triggers the detection of circuit. The light and beeper should go "on" as if a live wire is being approached.

Approaching the dome near a Computer screen or a TV screen (not liquid crystal display type) should also trigger the tester while on the 240V selection.

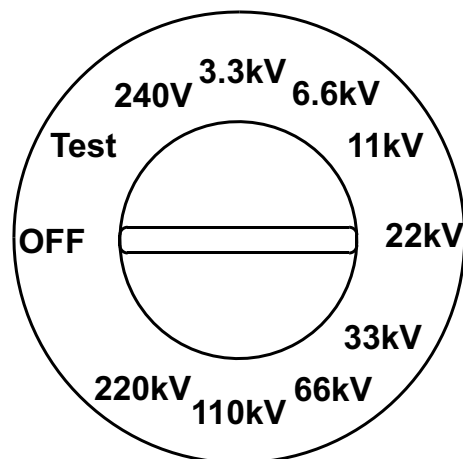

## Typical Uses

- Identify and check live cables.
- Check and detect live high voltage cables (using extension hot stick).
- Find fault in flexible cables.
- Check earth equipment.
- Service neon lighting.
- Trace live wires.
- Check high frequency radiation.
- Detect residual or induced voltages.

## Broken Wires In Cables

Faults in damaged flexible cables are found by applying low voltage to each conductor. Earthing the remainder (the wires that do not need to be traced. Do not earth the live wire, so that they can be detected by the Hi-Prox.) and moving the tester along the cable until the change in condition is obtained. (Flexible cables, as used in mining and building industries, are readily repairable when the break in the cable is located).



## High Voltage Testing

The rotary switch (attenuator) is used to identify and differentiate various HV live cables. **The tester must be used in conjunction with a long and insulating rod when measuring high voltage (kV).**

The Hi-Prox is a non-contact high voltage detector. The detector should never be in contact with live conductors. Live conductors emit a radiated field that can be detected by the detector's sensor.

**✘ When working under high voltage systems, please wear the insulation gloves and rubber shoes. Do not touch live conductors with this detector.**

An increase in voltage means an increase in its radiated field strength. The radiated field strength quickly decreases with distance and/or ground shielding. The radiated field from a cable where conductors supplying 3-phase power are close together tend to cancel out. The rotary switch, or attenuator, is used to identify and differentiate various HV live cables.

**✘ The detector should only be used in conjunction with an insulated rod or hot stick when measuring high voltage.**

Check to see if the detector is in good operating condition. Select the appropriate test range. It is advised that you start with a lower test range setting than the actual working voltage. Then perform the test again with the higher settings. The user may also opt to use a lower setting to check for lower voltages on a conductor.

With the hot stick, gradually move the detector towards the live conductor until its warning signal is triggered. Again, do not touch the live conductor with the detector.

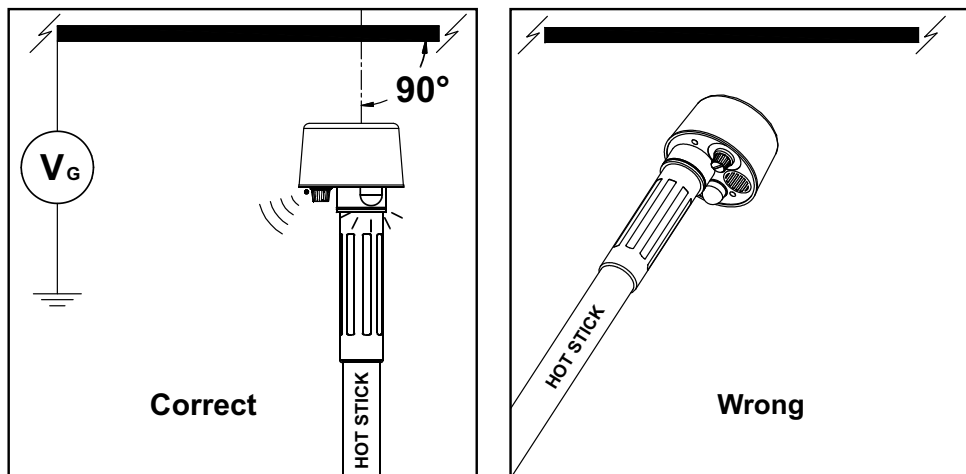

## Faults (Open) Cables

The Hi-Prox detector is capable of detecting faults in certain flexible cables. For a cable that is still energized, set the detector's sensitivity so that it triggers. Move the detector along the cable until you notice a change. An audible sound and LED will be on when the sensor is on the supply side of the open and will turn off when on the other side.

## Limitations Of The Hi-Prox

*It is recommended that this tester is not used in HV yards of mixed voltages. In the presence of mixed voltages, the tester can become unreliable.*

**Problems can arise when the tertiary circuit of a 275/133/11kV transformer is tested. The electric field of the HV and MV bus bars can trigger the detector when it is about 3m above the ground. This is common with most of the electric field voltage detectors. Users should be aware of it. The tester can pick up adjacent circuit to the one being tested and indicates the wrong information to the user.**

## Changing Batteries

The Hi-Prox uses 3 x1.5V "C" cells batteries. Open the battery cover (turn counter-clockwise) to remove the batteries. Ensure polarity is respected.

### General

- Operating Temperature : -15°C~55°C
- Storage Temperature : -20°C~65°C
- Humidity : 93% R.H. @ 40°C
- Case Height : 260mm
- Case Width : 96mm
- Weight : Approx. 550g(Batteries included)
- Power Source : 1.5V "C" x 3 Alkaline Batteries
- Safety Standard :
  - EN 61326-1
  - EN 61000-4-2
  - EN 61000-4-3
  - EN 55011

## Limited Warranty

We warrant the product to be free from defective materials or factory workmanship. We agree to repair or replace this product with no charge for parts and service, if used under normal operation and is a result of manufacturer defects. If we are unable to repair or replace this product, we will make a full refund of the purchase price. Consult the user manual for proper instruction regarding use of this instrument. Our obligation under this warranty is limited to repairing, replacing or making refund of this test equipment which proves to be defective within 36 months from the date of purchase.

This warranty does not apply to any of our products which have been repaired or altered by unauthorized persons in any way. In our sole judgement, if the stability or reliability of products are injured, or which have been subject to misuse, abuse, misapplication, negligence or accident, or the serial numbers have been altered, defaced or removed, this warranty will not apply.

All warranties implied by law are hereby limited to a period of 36 months, and the provisions of the warranty are expressed in lieu of any other warranties expressed or implied.

The purchaser agrees to assume all liability for any damages or bodily injury which may result from the use or misuse of the product by the purchaser, or its user, his employees, or others, and the remedies provided by this warranty are expressed in lieu of any other liability we may have included in incidental or consequential damages.

We reserve the right to discontinue models at any time, or change specification, price or design, without notice and without incurring any obligation.