



The user manual of LED display screen and RH-128A control card.

I Hardware parameters

1、The maximum number of points

P10 solid color: 64*1024 96*672 128*512 (4 pieces high and 32 pieces wide; 6 pieces high and 21 pieces wide; 8 pieces high and 16 pieces wide)

P10 bicolor: 64*512 (4 pieces high and 16 pieces wide)

P16 bicolor: 64*512 (8 pieces high and 32 pieces wide)

F3.75 F5 solid color: 128*512 96*672 64*1024 (4 pieces high and 8 pieces wide; 3 pieces high and 10 pieces wide; 2 pieces high and 16 pieces wide)

F3.75 F5 bicolor: 128*256 96*336 64*512 (4 pieces high and 4 pieces wide; 3 pieces high and 5 pieces wide ; 2 pieces high and 8 pieces wide)

2、Adaptive scope

Single primary color/ double primary colors LED display screens with various scanning specifications of 1/16, 1/8 and 1/4

3、Number of programs

256 programs are available, and each one could be set up with 8 free partitions.

4、Communication mode

usb Serial ports Communication (RS-232) GPRS

5、Communication distance

A USB extension cable should be no more than 8m (the cable of good shield quality can amount to 15m)

The baud rate is 115200: the length of serial wire can't be over 15m

The Baud Rate is 9600: the length of the serial line should be no more than 50 meters.

6、Supply voltage

Voltage range supported: 4.0V-5.5V (communication voltage best kept at about 5V)

II Status of indicator light

D5: The power supply lamp, always on with electricity (the light of the control card)

III Product advantages

- 1、Brightness is adjustable, with complementary length and width
- 2、Display Mode: 30 display effects + 28 special display effects
- 3、Supporting two-way communication, orderly play, fixed time play and fixed length play
- 4、In order to improve the reliability and feasibility of products, we adopted two-chip proposal instead of the mainstream single chip proposal, thus the reliability and recognition rate of USB communication has been greatly improved. The recognition rate of USB is up to 99%, and the repair rate of the whole series of products is less than 0.3%
- 5、Cost-effective, go smoothly, steady operation
- 6、Achieve wireless transmission through matching connection with GPRS, WIFI module



IV Connection of the control card and display screen

First: Schematic diagram of control card connector

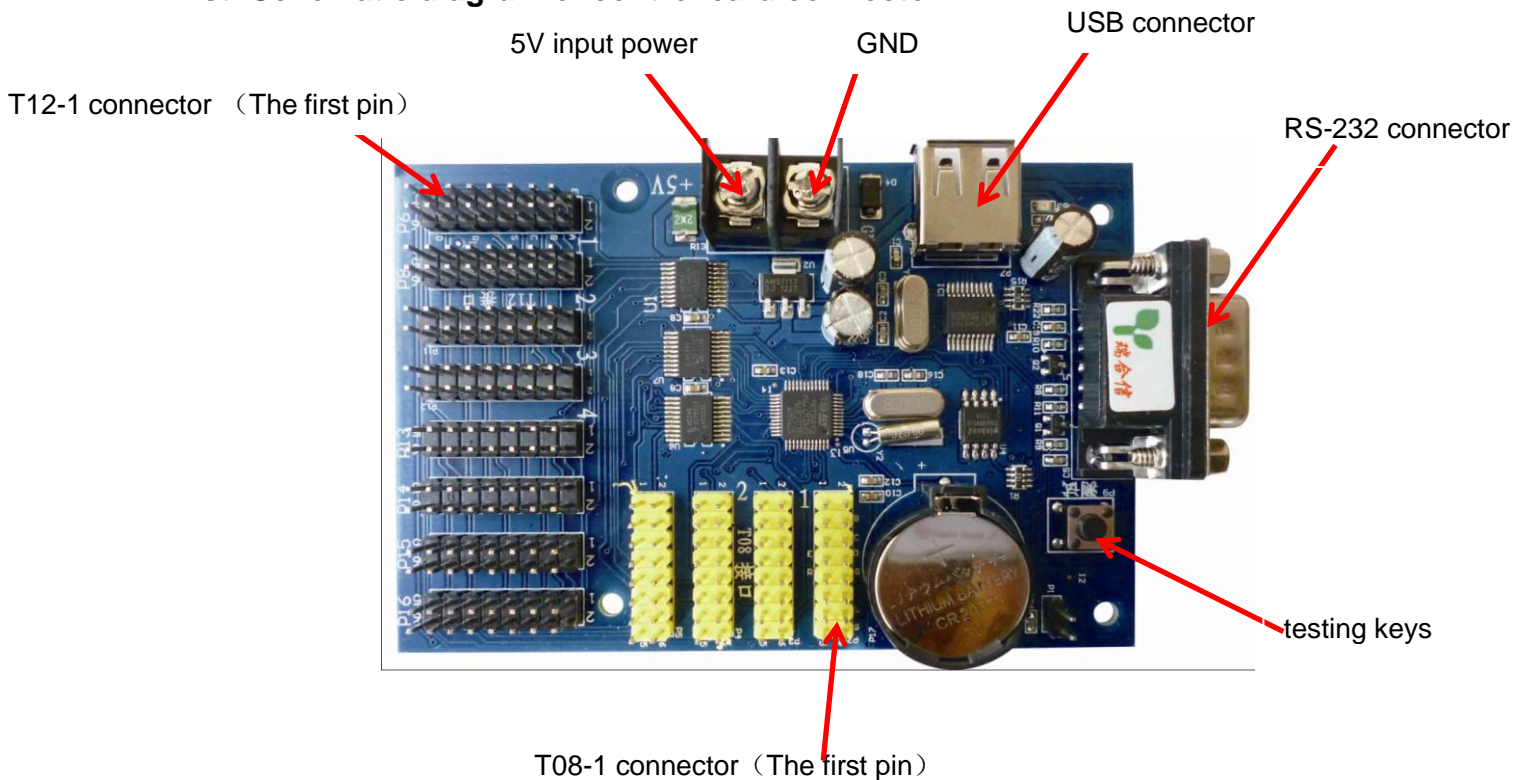

First, you can connect the end and power supply of the power module to the end and power supply of the control card, according to scanning mode of the display screen, If it is 1/4 scanning connect T12 connector and 1/16 (or 1/8) scanning connect T08 connector. if it is 1/4 scan then connect to T12 port, and if it is 1/16(or 1/8) scan then connect to T08 port. The first pin between the display screen and control card should correspond to each other when connecting winding displacement.

After connecting, please pay attention to check the cable connections. If there is no problem, then you can electrify it. After electrifying, the top right corner of screen will display the version of control card at first, then display corresponding program information when it leaves the factory.

If the display is confused or you need to test cell plate lights situation, please press test button which is on the control card, debugging screen, and the screen will switch a scanning mode after pressing test button.

Test states such as left-hand diagonal, black screen, full bright, right-hand diagonal appear successively

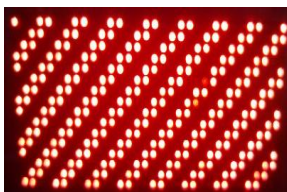

left-hand diagonal



black screen

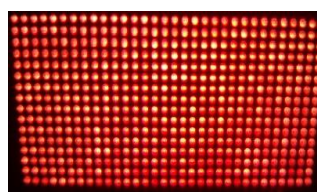

full bright



right-hand diagonal

If not, please check winding displacement connection and display screen.

V USB flash disk communication

USB flash disk communication setting steps



Step one: screen setting

If you choose the RH-128A USB communication, there is no need to use a data line to connect the control card and the computer. Open the software directly, click "Setting" to set the screen parameters, and input the password (168 or) 888. Enter the parameter interface of setting screen, select RH-128A for the control unit and USB flash disk for the communication mode, then based on the specification of current display screen to perform "quick setting", click "advanced setting" for detailed setting of OE polarity and length-height of the screen, and if data polarity and row order need adjusting in the "advanced setting" option, click "more functions" to modify. As the chart shows: the following chart is the interface of quick settings



After adjusting the display screen parameters, click "Save screen parameters" to complete setting the screen parameters of the control card.

Step two: Edit programs

First add the programs, and then add the corresponding subtitles, text, or time information etc. to edit the relevant program contents. (Please refer to the instruction of the software for specific operations.)

Step three: save the program to U disk

After the completion of program edition, press the "Send" button appeared on the right top corner of control software. The following dialog will appear. Select "U disk" and click "Save".



If you want to adjust time or adjust brightness, to set the timer switch etc. , you need to click the configuration button next to the send button. After finishing the amended contents, click "Save to U disk".

Step 4: the USB data can be read by the control card.

After the file is saved, insert U disk to the USB interface on the control card. After about 10 seconds, the control card will be restarted which will indicate version and then program.

Caution: After reading the U disk data, if the font on the viewing screen is abnormal or gibberish, please refer to the above steps to reset the screen parameter, etc.

If the U disk can't be read or the screen doesn't response after reading, please format the U disk and try again or change another U disk.

VI Serial ports Communication

The standard of serial communication:

- a、 the software version must be 3.1.555 or above (a version above 3.1.686 is recommended)
- b、 The baud rate is 115200: the length of serial wire can't be over 15m
The Baud Rate is 9600: the length of the serial line should be no more than 50 meters.
- c、 he serial thread is a through line which directly connects the control card and the computer

Connection method of through line:





Steps of setting the serial communication:

Step one: the connection of the computer and the control card

After connecting the power supply and flat cable of the control card with the display screen, one more straight serial line is required to be connected to the computer. If the computer's own serial port is in normal situation, it can be connected with it directly. Otherwise, a USB serial port line is required. If using USB, the USB drive needs to be installed, which can be downloaded from the www.rhxled.com "Data download".

Step two: Setting screen parameter

One difference from the USB flash disk setting is to transform the communication mode into serial communication (RS-232) and choose the relevant port number which subject to the one searched by the software automatically. Default of baud rate is 9600, which can be selected as 115200 and 38400. As shown in the figure below; if the serial port line is connected normally and the control card works normally, the computer will search the control card through serial port when the screen parameters setting is opened. On the interface of the screen parameters setting it will hint "Card is found connecting on: COM3, card type is: RH-128A, baud rate is : 9600". Screen parameters can be saved after adjusted



Step three: Edit programs

First add the programs, and then add the corresponding subtitles, text, or time information etc. to edit the relevant program contents. (Please refer to the instruction of the software for specific operations.)

Step four: Sending Program

Click send to send the program directly. The display screen will be restarted after sending the program, and it will display the card model and the version number. Then it will display the program content.

Note: if it hints "No Card Found", check whether the connection between the serial port line and the control card as well as the computer is well-connected at first and whether the serial port line is straight through or not. Whether the serial port of computer or USB to Serial port is normal or not.

VII Serial ports Communication

GPRS communication requirements: GPRS communication must use a direct-through line to connect GPRS module with 128A control card, and the detailed transmitting methods are shown in the method for using



Zhengzhou Ruihexin Electronic Technology Co., Ltd.

GPRS module.

Thank you for using "the RH-128A control card of Zhengzhou Ruihexin". If you have any technical questions with the control card that can't be resolved, please do not hesitate to contact us.

Technical support: 15238080525 18037131927 18037891691 18037891692