

# LAKWOOD INSTRUMENTS™ MODEL 150 BOILER WATER CONDUCTIVITY CONTROLLER

## ***INSTALLATION & OPERATION MANUAL***

SERIAL #: \_\_\_\_\_



### ***Lakewood Instruments***

7838 North Faulkner Road, Milwaukee, WI 53224 USA

Phone (800) 228-0839 • Fax (414) 355-3508

<http://www.lakewoodinstruments.com>



# Lakewood Instruments™ Model 150 Controller

## Quick Installation Sheet

1. Install the controller on a flat, non-vibrating surface. Use the four (4) supplied mounting feet. Do not mount the controller to a steel object that has a large temperature change (side of cooling tower, etc). This can cause water to condense inside the enclosure.
2. Install water meter, chemical pumps, plumbing assemblies and the conductivity sensor (see drawing on back for suggested installation).
3. Open the front cover of the Model 150 Controller.
4. Wire the flow switch (use jumper wire for no flow switch), conductivity sensor, water meter and 4-20 mA output, if applicable (see drawing in manual). Ensure wiring connections are correct or damage may occur.
5. If doing a conduit installation, remove receptacles, and wire pumps and blowdown valve. Refer to the instruction manual for more details.
6. Use a standard screwdriver to set the power selector switch to either 115 VAC or 230 VAC operation.
7. Reinstall the front cover keypad making sure the ribbon cable is properly attached.
8. Plug in chemical pumps and blowdown valve to controller (unless hardwired in step #5).
9. Apply power to the model 150 controller, press **CLR** twice, press **6** System setup, press **2** INITIALIZE, press **2** WHOLE CTRLR, press **1** Yes. After initialization, press the **CLR** key several times until you get to the main menu.
10. Press **1** Process, Press **ENT**. This screen allows manual control of the relay outputs to test the chemical pumps and blowdown valve. Press the number for the relay you want to operate; 1 for bleed, 2 for relay 2, and 3 for relay 3. The box will flash to show that that relay is in manual control. To restore automatic control press that number again. Press **CLR** to return to the Process screen.
11. To calibrate conductivity take a sample with a handheld conductivity meter, press the **PRO** button, type in conductivity value, press **ENT** (skip if not using conductivity sensor). For more details refer to appropriate section of this manual
12. Program the model 150 relays for blowdown, chemical feed schemes, water meter input, and 4-20 mA output. See instruction manual for more details.

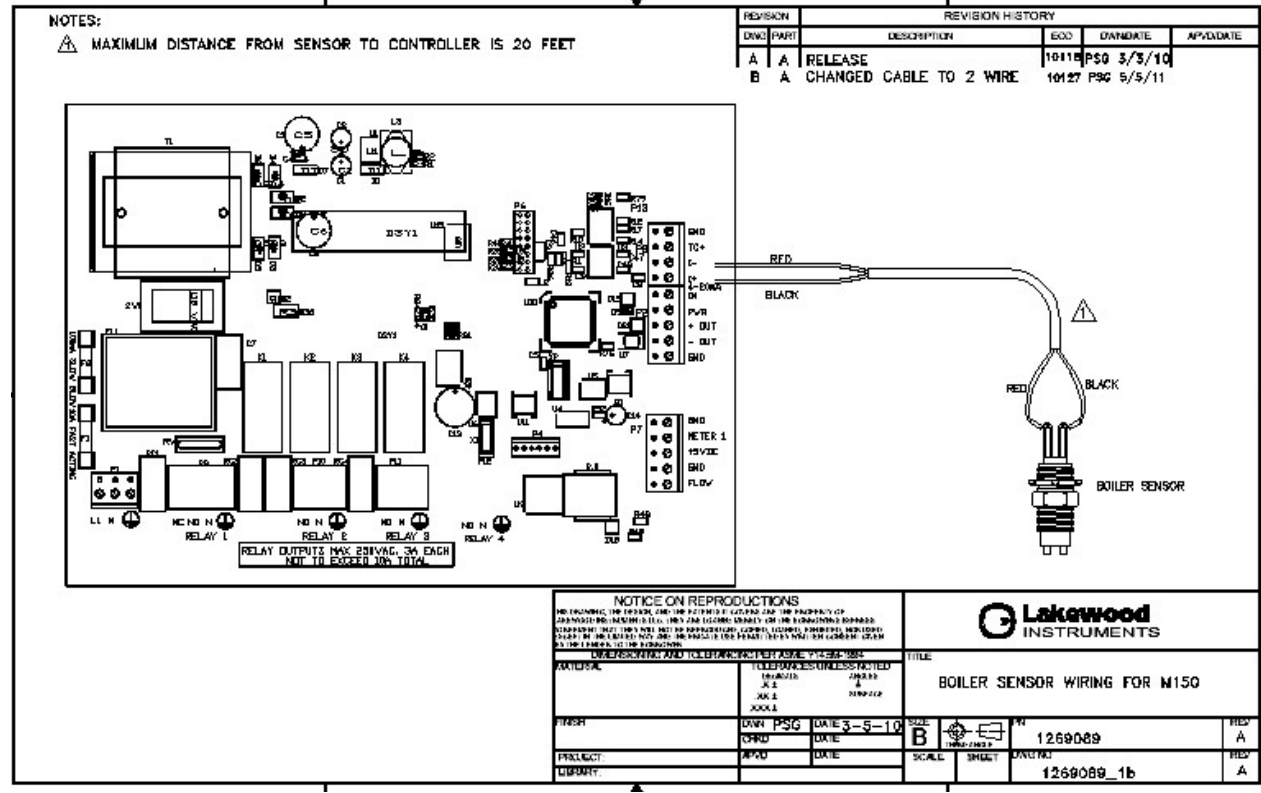
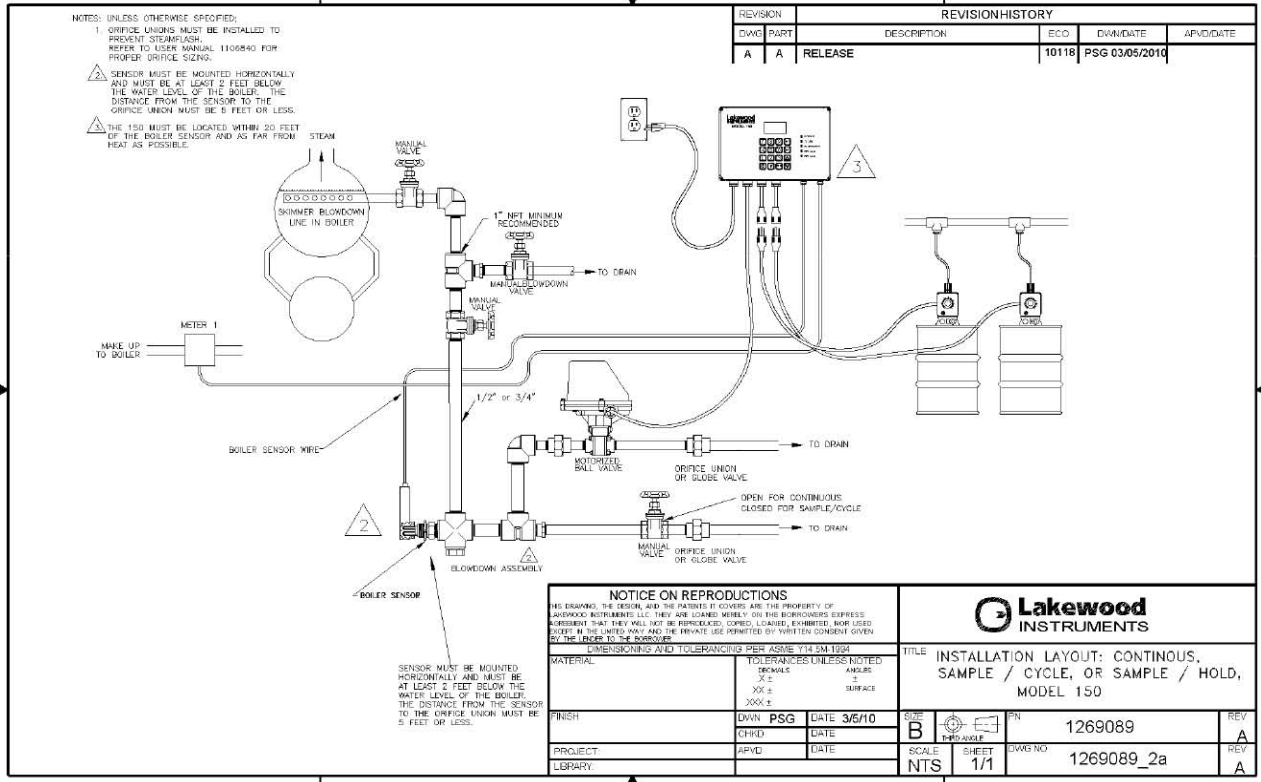

# **IMPORTANT NOTICE**

## **WARNING: CHEMICAL FEED**

All electromechanical devices are subject to failure from a variety of causes. These include mechanical stress, component degradation, electromagnetic fields, mishandling, improper setup, physical abuse, chemical abuse, improper installation, improper power feeds, and exposure.

While every precaution is taken to insure proper functioning, extra precautions should be taken to limit the ability of over-feeding by limiting chemical quantities available, secondary shut-downs, alarms, and redundancy or other available methods.

## **CAUTION: POWER SOURCE AND WIRING**

Low voltage wiring and high voltage (110 plus) should not be run in the same conduit. Always run separately. Even shielded low voltage is not a guarantee of isolation.

Every precaution should be taken to insure proper grounding and elimination of shorting or Electromagnetic field (EMF) interference.

## **WARNING: ELECTRICAL SHOCK**

To reduce the risk of electrical shock, this equipment has a grounding-type plug that has a third (grounding) pin. This plug will only fit into a grounding - type outlet. If the plug does not fit into the outlet, contact a qualified electrician to install the proper outlet. **DO NOT** change the plug in any way.



## ***Lakewood Instruments***

We thank you for your selection and purchase of a Lakewood Instruments product.

With proper care and maintenance, this device should give you many years of trouble-free service. Please take the time to read and understand this Installation and Operation Manual, paying special attention to the sections on **OPERATION** and **MAINTENANCE**.

If, in the future, any parts or repairs are required, we strongly recommend that only original replacement parts be used. Our Customer Service Department is happy to assist you with your parts or service requests.

 **Lakewood Instruments Customer Service and Technical Support Departments can be reached by calling (800) 228-0839 or faxing (414) 355-3508, Monday through Friday, 7:30 a.m. - 4:30 p.m. CST.**

 **Mail should be sent to:**

**Lakewood Instruments  
7838 North Faulkner Road  
Milwaukee, WI 53224 USA**





# MODEL 150

---

## Table of Contents

1.0 Introduction.....	7
2.0 Features, Benefits and Specifications.....	8
2.1 Features.....	8
2.2 Benefits.....	9
2.3 Specifications.....	9
2.4 Ordering Information .....	10
3.0 Unpacking, Mounting and Installation.....	11
3.1 Unpacking.....	11
3.2 Mounting the Enclosure.....	11
3.3 Plumbing Installation.....	12
3.3.1 Orifice Sizing chart.....	13
3.4 Electrical Installation.....	14
3.4.1 Incoming power 115/230 VAC.....	14
3.4.2 Relay Outputs.....	15
3.4.3 Flow Switch Wiring.....	15
3.4.4 Sensor Wiring.....	16
3.4.5 Water Meter.....	16
3.4.6 4-20 mA Output Wiring.....	16
4.0 Starting Up the Controller.....	17
5.0 Functional Overview.....	18
5.1 Front Panel.....	18
5.2 Display.....	19
5.3 Keypad.....	19
5.4 Menu.....	19
5.4.1 Menu Flow Chart .....	20
6.0 Operation of the Controller.....	21
6.1 Process Screen.....	21
6.2 Manual Operation of the Relays.....	22
6.3 Calibration of Conductivity.....	22
6.3.1 Calibration in Continuous Sample Boiler Control .....	22
6.3.2 Calibration in Sample/Cycle Boiler Control .....	23
6.3.3 Calibration in Sample Hold Boiler Control.....	23
6.4 Main Menu.....	24
6.4.1 Process Screen .....	24
6.4.2 Configuring the Relays .....	25
6.4.2.1 Configuring the Blowdown Relay .....	25
6.4.2.1.1 Setpoint Values.....	26
6.4.2.1.1.1 Deadband .....	26
6.4.2.1.1.2 Blow Alarm Time .....	27
6.4.2.1.2 When to Blow.....	27

6.4.2.1.3	Boiler Methods.....	27
6.4.2.1.3.1	Continuous Sample .....	28
6.4.2.1.3.2	Sample/Cycle .....	28
6.4.2.1.3.3	Sample Hold .....	29
6.4.2.1.4	Ball Valve Delay.....	31
6.4.2.2	Configuring Relays 2 and 3.....	31
6.4.2.2.1	Disabled.....	31
6.4.2.2.2	By Setpoint .....	32
6.4.2.2.2.1	Setpoint.....	32
6.4.2.2.2.2	Deadband .....	33
6.4.2.2.2.3	Timeout.....	33
6.4.2.2.2.4	When to Feed .....	34
6.4.2.2.3	By Water Meter.....	34
6.4.2.2.4	By % of Blowdown Time .....	34
6.4.2.2.5	By Percent of Time .....	35
6.4.2.2.6	As an Alarm Relay .....	36
6.4.3	Alarms.....	36
6.4.4	Water Meter .....	37
6.4.5	Setup of the 4-20 mA Out.....	38
6.4.5.1	Set the 4-20 mA Range.....	38
6.4.5.2	Manual Control.....	38
6.4.5.3	Calibrate the 4-20 mA Output.....	38
6.4.6	System Setup Menu.....	39
6.4.6.1	Process Parameters.....	39
6.4.6.1.1	Anti-Flashing.....	39
6.4.6.1.2	Enable/Disable the Conductivity Input .....	40
6.4.6.2	Initialize .....	40
6.4.6.3	Firmware Version .....	40
6.4.7	Setting the Clock.....	41
7.0	Maintenance.....	42
7.1	Sensor Maintenance.....	42
7.2	Replacing the Fuses.....	43
8.0	Troubleshooting.....	44
8.1	Error Messages.....	44
9.0	Factory Service.....	46
10.0	Drawings	
10.1	Wiring Boiler Sensor.....	1269089_1A
10.2	Suggested Installation Layout .....	1269089_2A
10.3	Wiring Water Meter.....	1269089_3A
10.4	Wiring Power Connections .....	1269089_5A
10.5	Wiring 4-20 mA Output.....	1269089_6A

## 1.0 Introduction

---

The Model 150 is a microprocessor based, menu driven, controller designed for use in boiler water applications. The Model 150 provides for conductivity tracking and control, flow monitoring and chemical injection. The Model 150 is NTL/CSA, and CE approved.

The Model 150 uses the latest in microprocessor capability, giving the user a high level of application flexibility. A digital display screen, multiple inputs, and an intuitive menu characterize this new technology.

The Model 150 is user-friendly with a graphical screen, numeric keypad, LEDs for power, alarm, flow, relay status, and display lighting. It accepts multiple inputs and is easily configured. It's a combination of reliability, accuracy, security and simplicity.

The model 150 is designed to control boiler water blowdown by use of any of the three boiler control methods; Continuous Sample, Sample/Cycle, or Sample Hold.

In the **Continuous Sample method**, the controller will continuously monitor the conductivity reading and control the blowdown relay based on setpoint.

In the **Sample/Cycle method**, the blowdown relay will energize for a user selected time called the Sample Time. At the end of the Sample Time the controller will compare the conductivity reading to the setpoint and if the conductivity is higher than the setpoint the Blowdown relay will stay energized until the conductivity reading is less than the setpoint. Once the setpoint is satisfied the blowdown relay will turn off for a user selected time called the Cycle Time. At the end of the Cycle Time the Blowdown relay will once again go into the Sample Time and repeat the above sequence.

In the **Sample Hold mode**, the blowdown relay will energize for a user selected time called the Sample Time. At the end of the Sample Time the blowdown relay will turn off and the controller will go into a 30 second Hold Time. The Hold Time allows time for the sample to stop flashing before actually reading the conductivity value. At the end of the Hold Time, the controller will go into a Reading Time of 15 seconds. At the end of the Reading Time, the controller will compare the conductivity reading to the setpoint. If the conductivity is higher than the setpoint, the controller will go into a user selected Blow to Resample Time and re-energize the blowdown relay repeat the above sequence. Once the setpoint is satisfied the controller will keep the blowdown relay turned off for a user selected time called the **Cycle Time**. At the end of the Cycle Time the Blowdown relay will once again go into the Sample Time and repeat the above sequence.

## 2.0 Features, Benefits, Specifications

---

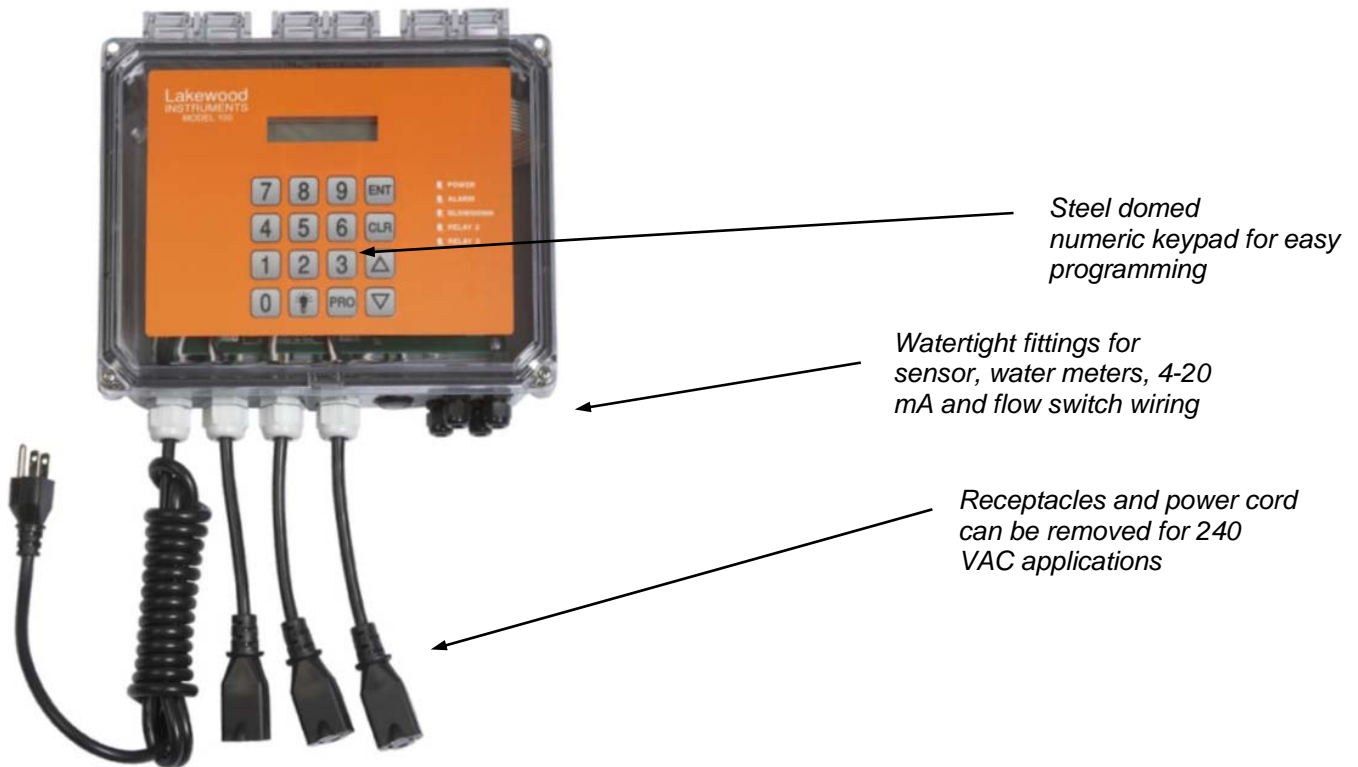

**Figure 1:**  
Model 150

### 2.1 FEATURES

---

- Controller is designed for use in boiler blowdown applications. The controller can operate in the continuous sample mode, sample/cycle mode, or sample/hold mode.
- Removable power cord and receptacles for conduit installations. Enclosure is rated NEMA 4X
- Three user configurable relays for conductivity control and chemical addition. These relays can be configured in multiple ways including by setpoint, by water meter, % of blowdown, % of time, and as a general alarm relay.
- One (1) water meter inputs, conductivity input, flow switch input, 4-20 mA output, are all standard features.
- Designed with a single circuit board for high reliability and lower cost.
- Large open shallow enclosure for easy wiring.
- Heavy-duty stainless steel domed numeric keypad and illuminated graphical display allow for quick and easy programming. Steel domed switches improve the tactile sensing and life expectancy of the keypad.
- The Model 150 controller stores all setpoints, calibration values, and relay configurations in an EEPROM. An EEPROM does not require a battery to retain information, so if power is lost these values will be retained for years. The 150 includes a capacitive backup device to retain information such as water meter total, and clock and calendar information. The capacitive backup device will never need to be replaced and will hold data approximately 1 day after each power failure.

## 2.2 BENEFITS

---

- Easy to program, the Model 150 Controller uses an intuitive menu and a numeric keypad for programming.
- No add-on options. Flow switch input, 4-20mA output, and three boiler conductivity control methods are standard.
- Multiple feed configuration methods available in a single controller.

## 2.3 Specifications

---

### **Conductivity range**

100-10,000  $\mu$ S

### **Conductivity sensor**

Two-electrode

### **Conductivity Resolution**

10  $\mu$ S

### **Accuracy & repeatability**

$\pm$  1.0% of scale

### **Deadband/Setpoint**

User programmable

### **Auto/Manual outputs**

Menu selectable

### **Keypad**

16 tactile steel-dome push buttons

### **Display**

16 X 2 Character

### **Enclosure**

NEMA 4x

### **Water meter input (1)**

Contact head, paddle wheel or Autotrol turbine

### **Timer**

Relay run time exceeded.

### **Output Signal**

One 4 – 20 mA, isolated or non-isolated optionally powered output for conductivity.

### **Output relays**

3 selectable use

### **Relay ratings**

3A each, 10A total

### **Power**

120/240 VAC 50/60 Hz 6W

### **Ambient temp**

32° - 150°F (0 - 60°C)

### **Storage temp**

-4° - 150°F (-20 - 65°C)

## 2.4 Ordering Information

---

### Controller Options

---

PART #	DESCRIPTION
1269089	Controller Model 150 controller only
1269092	Controller Model 150, w/SR2, MBV-1, 1/2" union, 1/16" orifice
1269093	Controller Model 150, w/SR2 and PLKT



### BOILER SYSTEM OPTIONS



SR2



PLKT



MBV1

1168374	SR2 Boiler water sensor with 20 ft cable and elbow. 3/4 NPT connection.
1233981	PLKT Plumbing Kit, 1/2 NPT
1166355	Orifice Plate, 1/2 NPT, 1/16".
1166354	Orifice Plate, 1/2 NPT, 1/8".
1167244	Orifice Union, 1/2 NPT.
1268608	MBV1 1/2 in NPT Motorized ball valve.
1268614	MBV2 3/4 in NPT Motorized ball valve.

### 3.0 Unpacking, Mounting and Installation

---

#### 3.1 Unpacking

---

Inspect the shipping carton for obvious external damage. Note on the carrier's bill-of-lading the extent of the damage, if any, and ***notify the carrier***. Save the shipping carton until your Model 150 controller is started up.

**☎** If shipping damage has occurred, call the Lakewood Instruments Customer Service Department at (800) 228-0839 and return the controller to the factory in the original carton.

#### 3.2 Mounting the Enclosure

---

The Model 150 can be mounted to a panel or to a flat non-vibrating wall. The Model 150 includes four removable mounting feet that can be attached in the horizontal or vertical position. The mounting feet are attached to the enclosure using four screws.

To change the position of the mounting feet: remove the screws from the feet and reposition either vertically or horizontally as desired and reattach the screws.

The dimensions of the enclosure in inches are:

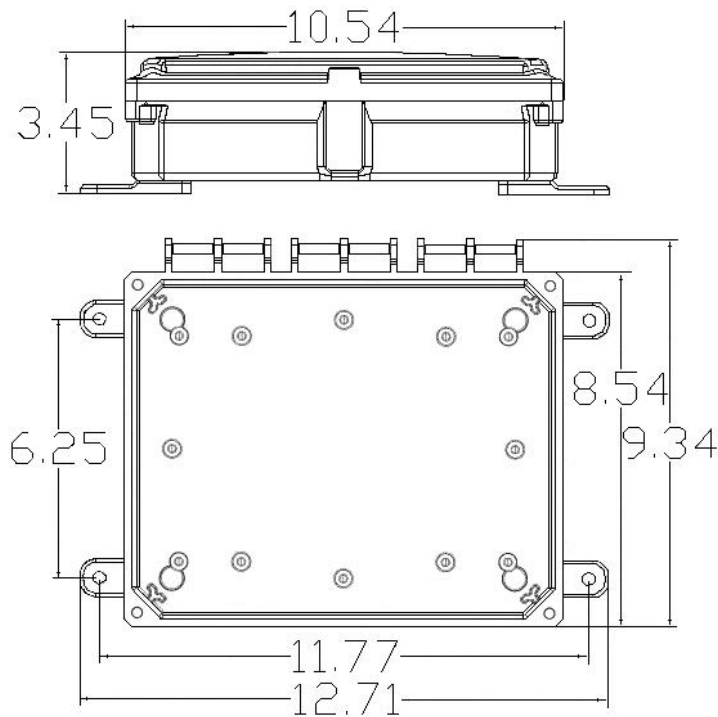

The model 150 has a shipping weight of less than 6 lbs.

### 3.3 Plumbing Installation

---

There are three methods of automatic control of the conductivity in a boiler; sample/cycle, continuous sample, and sample/hold. To decide if you should use continuous sample, or sample/cycle or sample/hold control, determine your blowdown rate requirement. If your boiler requires greater than 1000 pounds per hour of blowdown to maintain conductivity then the continuous sample method should be used. If your blowdown requirement is less than 1000 pounds per hour, the sample/cycle or sample/hold methods are appropriate.

The model 1575e can be used for either sample/cycle control, sample/hold control, or continuous sample control of the conductivity in the boiler. The installation drawing in the back of this manual shows how to plumb the boiler sample line so that it can be used as sample/cycle, sample/hold, or continuous sample.

To prevent steam flashing and damage to the sensor and controller refer to the installation drawings in the back of this manual and the notes below.

- Use piping from the boiler skimmer line as the sample and blowdown line.

***NOTE: DO NOT USE THE BOTTOM BLOWDOWN OF THE BOILER AS THE SAMPLE OR AUTOMATIC BLOWDOWN LINE.***

- The maximum allowed wire distance between the controller and the sensor is 20 ft.
- If using conduit between the sensor and controller, allow a place for water to escape if the sensor leaks. This will help prevent water damage to the controller.
- Use orifice plates or globe valves to prevent steam flash. The orifice plates or the globe valve should be mounted within 5 feet of the sensor. Orifice plates (or globe valve) and the sensor must be installed horizontally (as shown in the drawing).
- The sensor should be located at least two feet **below** the water level in the boiler.
- Ensure that there are no restrictions between the skimmer line and the orifice plates (or globe valve) and all valves upstream of the boiler sensor are fully open.
- Be sure to provide isolation valves in the sample line to allow for maintenance of the sensor.
- Refer to section 3.3.1 for the orifice sizing chart

***NOTE: DO NOT RUN THE SENSOR WIRING IN THE SAME CONDUIT AS THE MOTORIZED VALVE WIRING.***



### 3.3.1 Orifice Sizing Chart

Refer to the chart below to determine the orifice size that is required for a specific flow rate.

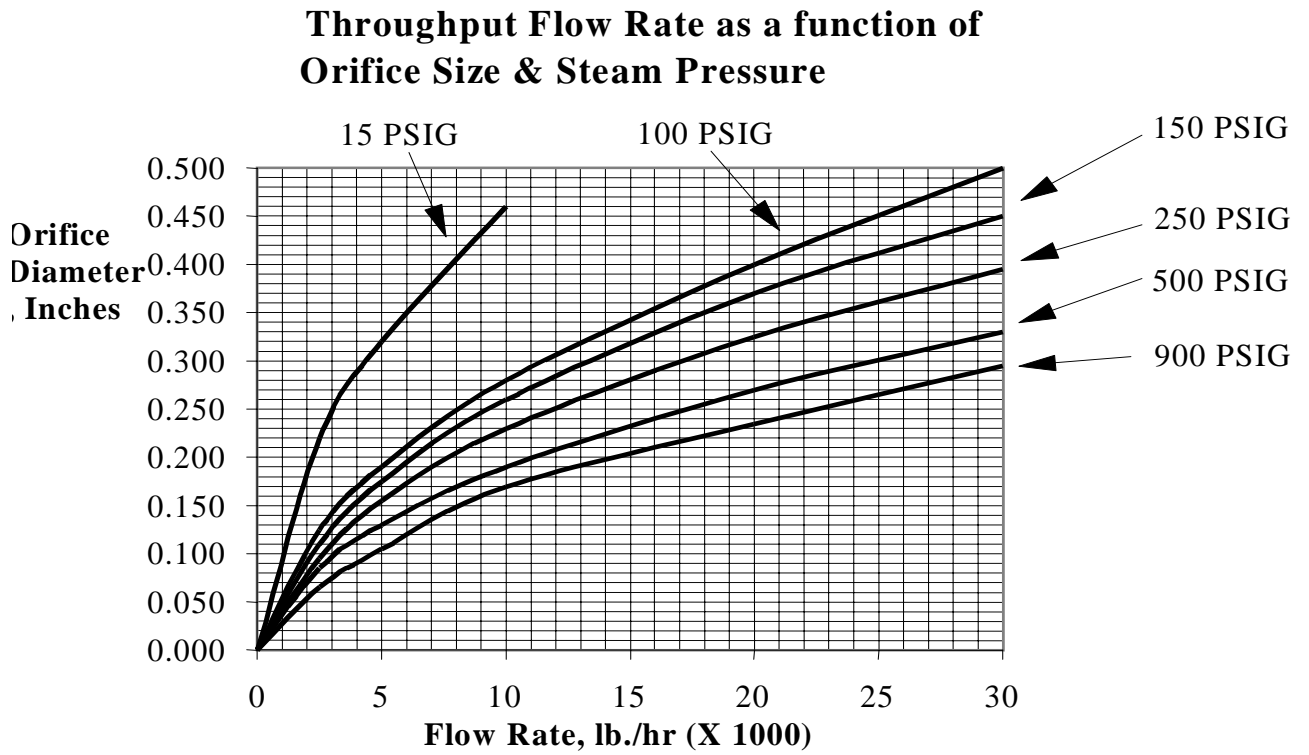

### 3.4 Electrical Installation

---

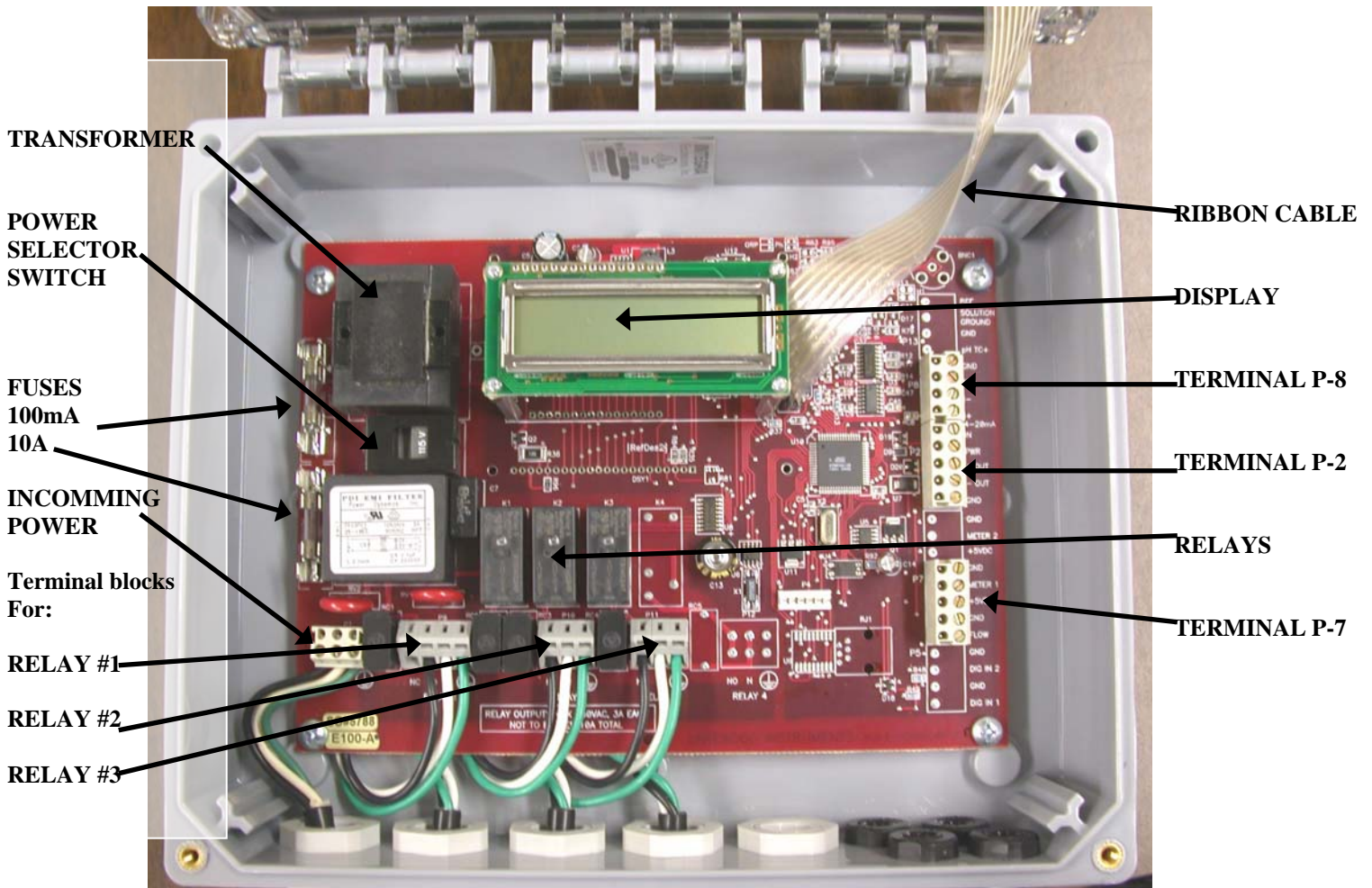

**Figure 2: Model 150 Electronics**

#### 3.4.1 Incoming Power 115/230 VAC

---

The Model 150 can be powered from either 115 VAC or 230 VAC at 50/60 Hz. There is a power selector switch located in the upper left-hand corner of the control board. To select the appropriate voltage, simply slide the switch from one position to the other with a standard screwdriver.

The Model 150 controller comes with a power cord and female molded receptacles for the blowdown valve and chemical pumps. The power cord and receptacles are rated for 115VAC. If the controller will be powered by 230 VAC, the power cord and receptacles will need to be removed and the incoming power and the relay outputs will need to be hard-wired.

The incoming power is connected to terminal block P1 at the bottom left corner of the control board. There is a hot or line input (L1), a neutral input (N) and an earth ground input ( $\oplus$ ). Refer to the drawing in the back of this manual for wiring instructions.

### 3.4.2 Relay Outputs

---

The relay outputs are of the same voltage as the power input. Ensure that the devices that are to be connected to the relay outputs are of the same voltage rating or damage will occur.

The relay outputs are wired to the female molded receptacles. The molded receptacle on the far left is relay #1 and the molded receptacle on the far right is relay #3. If 115 VAC is used simply plug your devices into the molded receptacles. If 230 VAC is used, remove the receptacles and hard-wire your devices to the relay outputs.

Relay #1 has both a normally open and normally closed contact. This is designed for use with any device that requires either or both types of contacts for operation, such as a motorized blowdown valve. The normally open (NO) contact energizes when the relay turns on and the normally closed (NC) contact is energized when the relay turns off. The other three relays only have a normally open contact. Each relay output has a neutral (N) connection and an earth ground connection (⊕) connection.



To operate the terminal blocks to remove or add wiring, insert a small screwdriver into the slot above each wiring connection and pry upward while removing or inserting the wire.

Refer to the drawing in the back of this manual for wiring instructions.

### 3.4.3 Flow Switch Wiring

---

The model 150 has a flow switch input. The purpose of the flow switch input is to disable the relay #2 and #3 outputs on a loss of flow in the system. Relay #1 is not controlled by the flow switch input. The flow switch input requires a dry1 contact. Any digital contact rated for 24 VDC and 500 mA may be used, such as a relay driven by the recirculating pump. The flow switch input is wired to terminal block P7 terminals 1 and 2.

If a flow switch is not used then a jumper must be installed across the flow switch connections in order for relays #2 and #3 to function. Refer to the drawings in the back of this manual for wiring instructions.

### 3.4.4 Sensor Wiring

The model 150 uses the Lakewood Instruments two-electrode conductivity boiler sensor. The maximum recommended wiring distance for sensor is 20 feet.

The conductivity sensor is wired directly to the P8 terminal block on the upper right corner of the control board. The black and white wires are wired to terminal # 1 (I+). The red and green wires are wired to terminal # 2 (I-). Terminals # 3 and # 4 are not used.

***NOTE: DO NOT RUN THE SENSOR WIRING IN THE SAME CONDUIT AS THE MOTORIZED VALVE WIRING.***

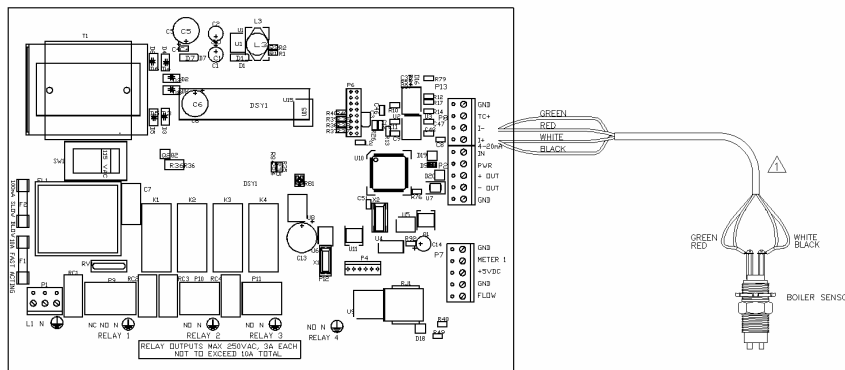

### 3.4.5 Water Meter

The Model 150 will accept one water meter input. Refer to the water meter manufacturer's manual for plumbing information.

The 150 series controller will work directly with the following types of meters: dry contacting head meters, Seametrics open collector output meters, Signet 2535 and 2540 paddle wheel meters, and the Autotrol 1 inch and 2 inch meters. Contact Lakewood Instruments for other types of water meters. The water meters are wired to terminal block P7 on the right-hand side of the control board. Refer to the drawing in the back of this manual for wiring instructions.

### 3.4.6 4-20 mA Output Wiring

The model 150 has one 4-20 mA output for conductivity. This output can be isolated or non-isolated, externally powered or internally powered. If the 4-20 mA output is internally powered then it is non-isolated. If the 4-20 mA output is externally powered then it is isolated.

The 4-20 mA output is wired to terminal block P2 on the right-hand side of the control board. Refer to the drawing in the back of this manual for wiring instructions.

## 4.0 Starting Up the Controller

---

Once the Installation is complete it is time to start up the controller.

Initiate sample flow to the controller by opening the sample line isolation valves. Check for leakage.

Power up the controller by turning on the circuit breaker or plugging the power cord into a 120 VAC receptacle.

For the initial startup it is best to initialize the whole controller to remove any settings that may be in the memory before programming the controller. Refer to section 6.4.6.2 of this manual to initialize the controller.

Set the clock by following section 6.4.7.

Configure the water meter input by following section 6.4.4.

Set the high and low conductivity alarms by following section 6.4.3.

Configure the relays for operation by following section 6.4.2.

Calibrate the conductivity by following section 6.3.

Configure the 4-20 mA output by following section 6.4.5.

Verify operation of the controller before leaving the area.

## 5.0 Functional Overview

---

### 5.1 Front Panel

---

**Figure 3:** Model 150 Front Panel with Display

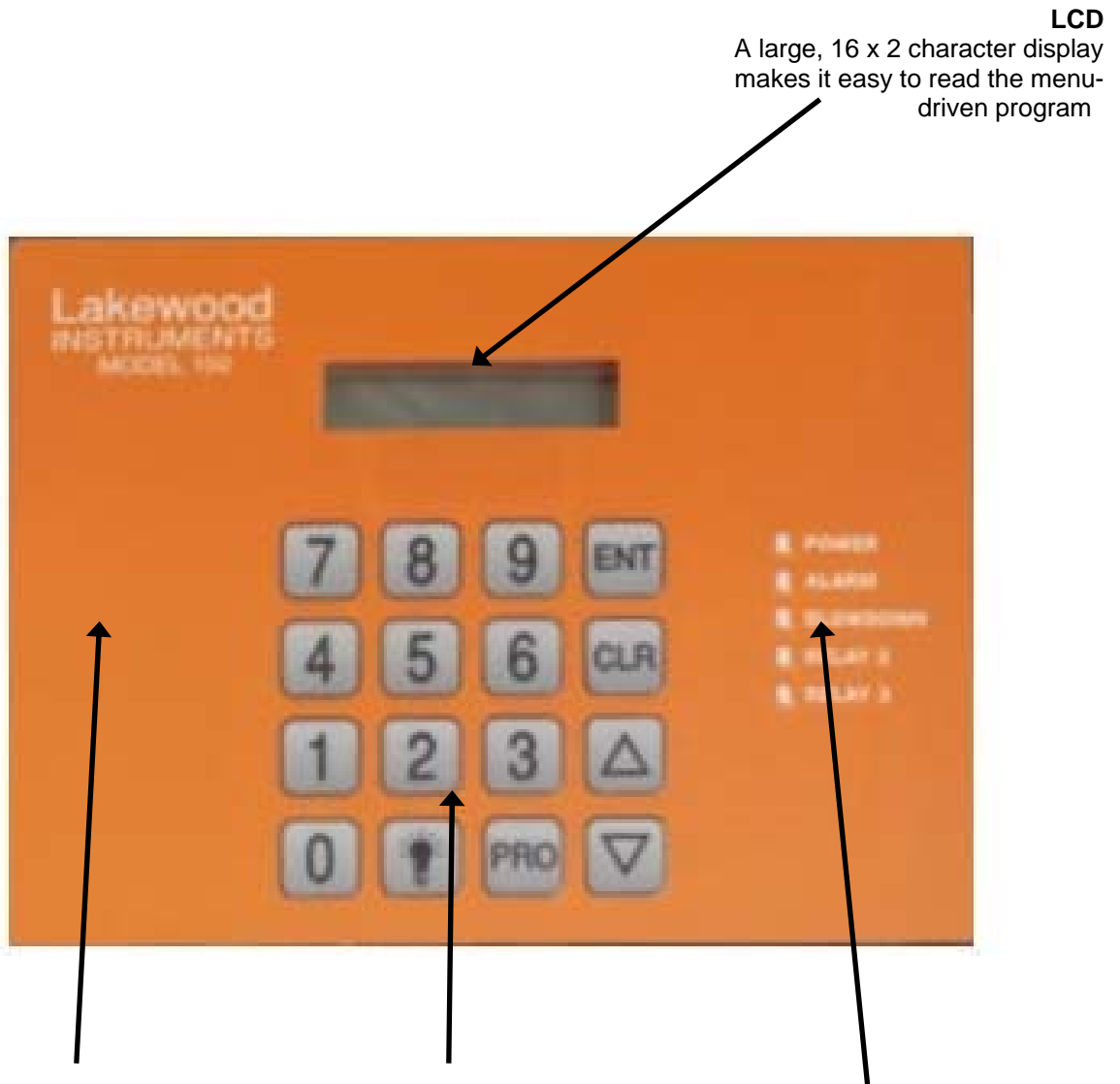

#### LCD

A large, 16 x 2 character display makes it easy to read the menu-driven program

#### ENCLOSURE

A sturdy NEMA 4X enclosure protects your controller. Make sure it is properly mounted on a flat, non-vibrating wall.

#### 16-BUTTON KEYPAD

**ENT** = For Menu selection and/or acceptance of selected values.  
**CLR** = To exit a Menu selection and/or skip input options.  
**PRO** = To program a Menu selection.  
**LIGHT BULB**= Display lighting on/off.

#### INDICATOR LIGHTS

LEDs for Power, Alarm, and Relay status. There are also LEDs that provide lighting to the display for 5 minutes when any button on the keypad is pressed.

## 5.2 Display

---

The model 150 uses a 16 x 2 LCD digital display for ease of viewing. It has two lines to display information such as the conductivity reading, alarms, relay status, relay configuration, clock, total flow, and menu selections.

## 5.3 Keypad

---

The model 150 uses a 16-key steel-domed numeric keypad for ease of programming. The keys have the following functions:

ENT	To accept a setting or to enter a screen.
CLR	To exit a screen or to access the main menu.
PRO	To calibrate the controller.
UP arrow	To move about in the menu.
DOWN arrow	To move about in the menu.
Number keys	To input a value or to select a menu item.
Light bulb	To turn on or off the display lighting LEDs.
Any Key	When any key on the keypad is pressed, the display lighting LEDs will turn on for five minutes. To manually turn off these LEDs, press the light bulb button.

## 5.4 Menu

---

The model 150 is programmed and calibrated by the use of a menu. The complete **Main Menu** has 7 available options that can be accessed. However, only one option can be viewed on the display at a time. Use the **↑** and **↓** keys to scroll through the options. Press **ENT** to enter the displayed programming option. As an introduction, here is a graphic overview of the first level of each option in the **Main Menu** to see how it operates. Complete details of each option are provided later in this manual. The entire menu is shown on the next page.

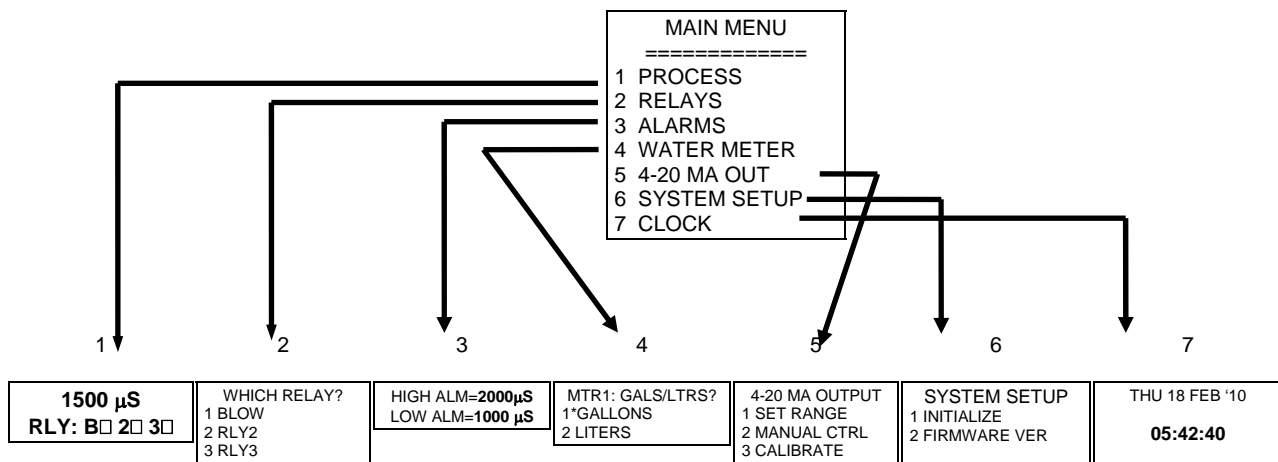

## 5.4.1 Menu Flow Chart

---

### MAIN MENU

#### 1 PROCESS

- DISPLAY DATE
- DISPLAY TIME
- DISPLAY ALARMS
- DISPLAY RELAY STATUS
- DISPLAY RLY 1 STATUS
- DISPLAY RLY1 SETTING
- DISPLAY RLY2 SETTING
- DISPLAY RLY3 SETTING
- DISPLAY WTR MTR TOTAL
- ENT**-MANUAL CONTROL OF RELAYS
- PRO**-CALIBRATION OF CONDUCTIVITY

#### 2 RELAYS

- 1 BLOW RELAY
  - 1 SETPOINT VALUES
    - SETPOINT
    - DEADBAND
    - BLOW ALARM TIME
  - 2 WHEN TO BLOW
    - ABOVE THE SETPOINT
    - BELOW THE SETPOINT
  - 3 BOILER METHODS
    - CONTINUOUS
    - SAMPLE/CYCLE
      - SET SAMPLE TIME
      - SET CYCLE TIME
      - SET RESAMPLE TIME
    - SAMPLE/HOLD
  - 4 BALL VALVE DELAY
    - SET DELAY TIME
- 2 RLY 2
  - 1 DISABLED
  - 2 SETPOINT
    - SETPOINT VALUES
    - WHEN TO FEED
  - 3 WATER METER
    - SET FEED TIME
  - 4 % BLOWDOWN
    - SET % BLOWDOWN
  - 5 % TIME
    - SET % ON-TIME
  - 6 ALARM RELAY
- 3 RLY 3
  - 1 DISABLED
  - 2 SETPOINT
    - SETPOINT VALUES
    - WHEN TO FEED
  - 3 WATER METER
    - SET FEED TIME
  - 4 % BLOWDOWN
    - SET % BLOWDOWN
  - 5 % TIME
    - SET % ON-TIME
  - 6 ALARM RELAY

#### 3 ALARMS

- HIGH ALARM
- LOW ALARM

#### 4 WATER METER

- GALLONS
  - CONTACT HEAD
    - ENTER GALS/CONTACT
    - RESET METER COUNTS
  - PADDLE WHEEL
    - ENTER K-FACTOR
    - RESET METER COUNTS
  - AUTOTROL 1 IN.
    - RESET METER COUNTS
  - AUTOTROL 2 IN.
    - RESET METER COUNTS
- LITERS
  - CONTACT HEAD
    - ENTER GALS/CONTACT
    - RESET METER COUNTS
  - PADDLE WHEEL
    - ENTER K-FACTOR
    - RESET METER COUNTS
  - AUTOTROL 1 IN.
    - RESET METER COUNTS
  - AUTOTROL 2 IN.
    - RESET METER COUNTS

#### 5 4-20 MA OUT

- SET RANGE
  - 4 MA VALUE
  - 20 MA VALUE
- MANUAL CONTROL
- CALIBRATE
  - 4 MA VALUE
  - 20 MA VALUE

#### 6 SYSTEM SETUP

- 1 PROCESS PARAMETERS
  - ANTI-FLASHING
  - ENABLE/DISABLE CONDUCTIVITY
- 2 INITIALIZE
  - CALIBRATION
  - WHOLE CONTROLLER
- 3 FIRMWARE VERSION

#### 7 CLOCK

- SET THE DATE AND TIME



## 6.0 Operation of the Controller

### 6.1 Process Screen

The screens that are used the most in the model 150 controller are the Process Screens. Below are the process screen views. The process screen has two sections. The top section shows the conductivity reading. The bottom section has user selectable readings as shown below.

<p><b>1 - DATE SCREEN</b></p> <div style="border: 1px solid black; padding: 5px; text-align: center;"> <p>1000 <math>\mu</math>S 25 FEB '10</p> </div>	<ul style="list-style-type: none"> <li>There are many different screens available in the <b>PROCESS</b> screen. These screens allow you to view the controller settings (incl. Date, time setting, relay set-ups, total flow, relay status, etc.) without the danger of altering them. Access these screens by using the <math>\uparrow</math> and <math>\downarrow</math> keys to scroll through the available screens.</li> <li>Press "<b>ENT</b>" to manually control a relay for testing or troubleshooting purposes.</li> <li>Press "<b>PRO</b>" to calibrate the conductivity.</li> </ul>	
<p><b>2 TIME SCREEN</b></p> <div style="border: 1px solid black; padding: 5px; text-align: center;"> <p>1000 <math>\mu</math>S 15:58:11</p> </div>	<p><b>3 ALL RELAY SCREEN</b></p> <div style="border: 1px solid black; padding: 5px; text-align: center;"> <p>1000 <math>\mu</math>S RLY: B <input type="checkbox"/> 2 <input type="checkbox"/> 3 <input type="checkbox"/></p> </div> <p>Note: A flashing box next to the relay number indicates that the relay is in manual control.</p>	<p><b>4 WATER METER SCREEN</b></p> <div style="border: 1px solid black; padding: 5px; text-align: center;"> <p>1000<math>\mu</math>S MTR: 100273 G</p> </div>
<p><b>5 BLOWDOWN RELAY SCREEN</b></p> <div style="border: 1px solid black; padding: 5px; text-align: center;"> <p>1000 <math>\mu</math>S <input type="checkbox"/>B: SET=99999 <math>\mu</math>S</p> </div>	<p><b>6 BLOWDOWN SAMPLE/CYCLE SCREEN</b></p> <div style="border: 1px solid black; padding: 5px; text-align: center;"> <p>1000 <math>\mu</math>S <input type="checkbox"/>B: SMPL 00:00:59</p> </div> <p>Note: This screen does not appear while in Continuous sample mode.</p>	<p><b>6 RELAY #2 SCREEN</b></p> <div style="border: 1px solid black; padding: 5px; text-align: center;"> <p>1000 <math>\mu</math>S <input type="checkbox"/>2: DISABLED</p> </div>
<p><b>7 RELAY #3 SCREEN</b></p> <div style="border: 1px solid black; padding: 5px; text-align: center;"> <p>1000 <math>\mu</math>S <input type="checkbox"/>3: BY WATER MTR</p> </div>	<p><b>8 ALARM SCREEN</b></p> <div style="border: 1px solid black; padding: 5px; text-align: center;"> <p>100 <math>\mu</math>S <b>LOW CONDUCTIVITY</b></p> </div> <p>NOTE: THE DISPLAYED ALARMS WILL ROTATE THROUGH ALL ACTIVE ALARMS.</p>	<p><b>Note:</b> The display lighting LEDs will turn on for five minutes when any button on the keypad is pressed. The display lighting can be turned off manually by pressing the light bulb button.</p>

## 6.2 Manual Operation of the Relays

---

All three of the relays can be operated manually. To manually operate the relays:

Go to the **Process** screen. Press “**ENT**”. You will be taken to a screen that looks like:

MANUAL-RLY 5 MIN  
RLY: B  2  3

**Note:** A flashing box next to the relay number indicates that the relay is in manual control.

Press “**1-3**” to manually change the state of a particular relay. If the relay is already on, pressing that number will turn it off. A five-minute countdown timer will start and the box next to the relay number will start to flash. After five minutes has expired the relay will return to automatic control. The relay will remain in manual control even if this screen is exited. A relay that is in manual control will stay in manual control until the five minutes expires or until that relay number is pressed again. The five-minute timer helps to prevent damage to the system if a relay is left in manual.

**WARNING: Manual control overrides all automatic control functions including the flow switch lockout. Use care when operating relays manually with no flow in the system.**

## 6.3 Calibration of Conductivity

---

The conductivity requires periodic calibration. Calibration is usually required after cleaning the sensor.

A calibration should always be performed with the sensor in the piping assembly with good flow past the sensor. It is necessary to have an accurate reading of the system water to properly calibrate the controller. A hand-held conductivity meter that tests the sample works well for this purpose.

**Note: The controller will allow up to one minute to enter a calibration value while the controller is in the calibration mode.**

### 6.3.1 Calibration in Continuous Sample Boiler Control

---

- Ensure that the controller is operating with good flow past the sensor.
- Take a sample of the water and measure with a hand-held conductivity tester.
- From the **PROCESS** screen, press “**PRO**” to enter the calibration screen. Use the keypad to input the conductivity reading from the hand-held. Press “**ENT**”.
- Take another hand-held sample to verify calibration.

**Note: The controller will remain in the calibration mode for only 1 minute before resuming normal operation.**

### 6.3.2 Calibration in Sample/Cycle Boiler Control

---

- Ensure that the controller is operating with good flow past the sensor.
- Take a sample of the water and measure with a hand-held conductivity tester.
- From the **PROCESS** screen, press “**PRO**” to enter the calibration mode. The controller will turn on the Blowdown relay for 30 seconds and display the following screen:

PLEASE WAIT  
OBTAINING SAMPLE

- At the end of the 30 second sample time, the Blowdown relay will turn off and the controller will display the following screen:

CALIBRATION:  
03200  $\mu$ S :59

- Use the keypad to input the conductivity reading from the hand-held. Press “**ENT**”.
- Take another hand-held sample to verify calibration.

**Note: The controller will remain in the calibration mode for only 1 minute before resuming normal operation.**

### 6.3.3 Calibration in Sample Hold Boiler Control

---

- Ensure that the controller is operating with good flow past the sensor.
- Take a sample of the water and measure with a hand-held conductivity tester.
- From the **PROCESS** screen, press “**PRO**” to enter the calibration mode and will start obtaining a sample. The controller will display the following message:

PLEASE WAIT  
OBTAINING SAMPLE

- After the sample is obtained, the controller will display:

CALIBRATION:  
03200  $\mu$ S :59

- Use the keypad to input the conductivity reading from the hand-held **before** the timer reaches **0:00**. Press “**ENT**”.
- The controller will respond with “**CALIBRATION COMPLETE**”.
- Take another hand-held sample to verify calibration.

**Note: It takes approx. 1 minute and 30 seconds to obtain a sample then the controller will remain in the calibration mode for only 1 minute before resuming normal operation.**

## 6.4 Main Menu

---

The **MAIN MENU** of the model 150 consists of 7 menu selections:

1. Process – Displays process conditions.
2. Relays – Relay configuration screens.
3. Alarms – Set the high and low conductivity alarms.
4. Water meter – Configure water meter type and reset total flow.
5. 4-20 MA Out – Set up and calibrate the 4-20 ma output.
6. System Setup – Initialize the controller and view firmware version.
7. Clock – Set the date and time.

Only one menu selection will appear on the screen at a time. Main Menu always appears in the top half of the screen. The bottom half of the display shows the selectable item in the menu. The screen will look like this:

MAIN MENU 1 PROCESS
------------------------

1. PROCESS
2. RELAYS
3. ALARMS
4. WATER METER
5. 4-20 MA OUT
6. SYSTEM SETUP
7. CLOCK

The **MAIN MENU** can be accessed from the **PROCESS** screen by pressing “**CLR**”.

To move about in the menu screens use the **↑** and **↓** keys to display the desired selection and press “**ENT**” or press the number key for the desired selection to access that selection.

Use the “**ENT**” key to accept a setting or to enter a screen. Use the “**CLR**” key to reject a setting or to exit a screen. From anywhere in the menu, pressing “**CLR**” will take you one step closer to the **MAIN MENU**.

Each of the **MAIN MENU** options is discussed in detail later in this manual.

### 6.4.1 The Process Screen

---

The process screen is where the conductivity value is displayed. The process screen is discussed further in section 6.1.

## 6.4.2 Configuring the Relays

---

To access the relay configuration screen from the **MAIN MENU**, press “2” or highlight **RELAYS** and press “ENT”. The following screen will appear.

WHICH RELAY? 1 BLOW	1 Blow 2 RLY2 3 RLY3
------------------------	----------------------------

### 6.4.2.1 Configuring the Blowdown Relay

---

The blowdown relay can be configured to operate in three different modes: Continuous Sample, Sample/Cycle, or Sample Hold. Each of these modes are explained further in the Boiler Methods section of this manual. **NOTE: The blowdown relay is not affected by the flow switch input.**

In **Continuous Sample mode**, the Blowdown relay works strictly by setpoint control.

In **Sample/Cycle mode**, the Blowdown relay will energize for a user selected time called the Sample Time. At the end of the Sample Time the controller will compare the conductivity reading to the setpoint and if the conductivity is higher than the setpoint the Blowdown relay will stay energized until the conductivity reading is less than the setpoint. Once the setpoint is satisfied the Blowdown relay will turn off for a user selected time called the Cycle Time. At the end of the Cycle Time the Blowdown relay will once again go into the Sample Time and repeat the above.

In the **Sample Hold mode**, the Blowdown relay will energize for a user selected time called the **Sample Time**. At the end of the Sample Time the Blowdown relay will turn off and the controller will go into a 30 second Hold Time. The **Hold Time** allows time for the sample to stop flashing before actually reading the conductivity value. At the end of the Hold Time, the controller will go into a **Reading Time** of 15 seconds. At the end of the Reading Time, the controller will compare the conductivity reading to the setpoint. If the conductivity is higher than the setpoint, the controller will go into a user selected **Blow to Resample Time** and re-energize the Blowdown relay repeat the above sequence. Once the setpoint is satisfied the controller will keep the Blowdown relay turned off for a user selected time called the **Cycle Time**. At the end of the Cycle Time the Blowdown relay will once again go into the Sample Time and repeat the above.

When the blowdown relay is selected for programming the following screen will appear.

BLOWDOWN SETUP: 1 SETPT VALUES	1 SETPNT VALUES 2 WHEN TO BLOW 3 BOILER METHOD 4 BALL VALVE DL
-----------------------------------	---

### 6.4.2.1.1 Setpoint Values

---

In the **SETPT VALUES** screen you will set the **SETPOINT**, the **DEADBAND** and the **BLOW ALARM TIME** alarm.

The **SETPOINT** is the conductivity value that you are trying to maintain. Check with your water treatment engineer to determine the conductivity setpoint for your system needs.

Follow these instructions to establish the controller's setpoint:

- Press "1" or highlight **SETPT VALUES** and press "ENT".

SETPOINT=  
4500  $\mu$ S

- Use the keypad numbers to enter the proper conductivity setpoint and press "ENT". When finished, you will automatically be moved down to the deadband.

### 6.4.2.1.1.1 DEADBAND

---

After the setpoint is established, the controller's deadband must also be set. "**Deadband**" refers to the amount of conductivity above and below the setpoint—a range within which the controller will not react. Due to continuous fluctuations in the conductivity level, it is necessary to have this deadband range or stable readings will be difficult to obtain. The Deadband should be a small percentage of the setpoint. Half the deadband amount will be automatically put above the setpoint, and the other half below it.

For example, a conductivity setpoint of 1,000  $\mu$ S with a deadband of 100  $\mu$ S would result in the BLOWDOWN relay opening at 1,050  $\mu$ S and closing at 950  $\mu$ S.

DEADBAND=  
000100  $\mu$ S

- Use the keypad numbers to enter the proper deadband setpoint and press "ENT". When finished, you will automatically be switched to the **BLOW ALARM TIME** alarm screen.

#### 6.4.2.1.1.2 BLOW ALARM TIME

---

The **BLOW ALARM TIME** alarm is designed to notify the operator of a problem in the blowdown system such as, a clogged strainer or the blowdown valve did not open. The blowdown timeout function is strictly a visual alarm feature displayed on the model 150 controller—it **will not close the blowdown valve**. If a relay is configured as an alarm relay, the **BLOW ALARM TIME** alarm will energize the alarm relay. To disable this function, simply program 0 hours, 0 minutes.

BLOW ALARM TIME=  
00:00

- Use the keypad numbers to enter the time in hours and minutes before this alarm will appear and press "ENT".

**Note:** The **BLOW ALARM TIME** alarm only applies to the **Continuous Sample control mode**.

#### 6.4.2.1.2 When to Blowdown

---

Most applications for boilers will blowdown *above* the setpoint. If desired, it is possible to configure the relay with a reverse setpoint. That is, blowdown occurs *below* the setpoint. If using this method be sure that the high conductivity alarm is set as high as possible.

- In the **BLOWDOWN SETPT** screen, press "2" or highlight **WHEN TO BLOW** and press "ENT".

WHEN TO BLOWDOWN  
1\*ABOVE SETPT

- In the **WHEN TO BLOWDOWN** screen, select either "1" **ABOVE SETPT** or "2" **BELOW SETPT**. Then press any key. An asterisk(\*) will appear next to the current selection.

#### 6.4.2.1.3 BOILER METHODS

---

The Blowdown relay can be configured for Continuous Sample, Sample/Cycle, or for Sample Hold mode. The Boiler Methods screen is selectable under the Blowdown setup screen:

BLOWDOWN SETPT:  
3 BOILER METHOD

- In the **BLOWDOWN Setup** screen, select "3" **BOILER METHOD**.

#### 6.4.2.1.3.1 CONTINUOUS SAMPLE

---

In **Continuous Sample** boiler applications, blowdown water is continuously flowing past the conductivity sensor and the controller is controlling the Blowdown relay based on a setpoint.

This mode is usually used for large boilers or boilers with very little condensate return. It is recommended that you use this mode if your blowdown rate requirement is greater than 1000 lbm/hr.

To configure the Blowdown relay for Continuous Sample mode:

<b>BOILER METHODS: 1 CONTINUOUS</b>
---

- In the BOILER METHODS screen, select "1" **CONTINUOUS**. The controller will respond with "CONTINUOUS SAMPLE press any key". Press any key to return to the BOILER METHODS SCREEN.

#### 6.4.2.1.3.2 SAMPLE/CYCLE

---

In **Sample/Cycle** boiler applications, the controller will sample the water on a timed basis and then control based on a conductivity setpoint. This mode is usually used for smaller boilers or boilers with a large amount of condensate return. It is recommended that you use this mode if your blowdown rate requirement is less than 1000 lbm/hr.

The Blowdown relay will energize for a user selected time called the **Sample Time** (the amount of time the blowdown valve will be open). At the end of the Sample Time the controller will compare the conductivity reading to the setpoint and if the conductivity is higher than the setpoint the Blowdown relay will stay energized until the conductivity reading is less than the setpoint. Once the setpoint is satisfied the Blowdown relay will turn off for a user selected time called the **Cycle Time** (the amount of time the blowdown valve will be closed). At the end of the Cycle Time the Blowdown relay will once again energize and go into the Sample Time and repeat the above sequence.

A typical **Sample Time** is 1 to 2 minutes with a Cycle time of up to 17 hours and 59 minutes. A short sample time is desired to prevent excessive loss of water and heat. Once the sample time is set, it should never have to be changed again.

The **Cycle Time** will need to be adjusted based on the steaming rate and make-up water quality. If using Sample/Cycle control and the conductivity does not rise to the setpoint, the Cycle time is probably set for too short of a time and will need to be adjusted to a longer period of time. If the conductivity is always above the setpoint, the Cycle time is probably set at too long of a time and will need to be adjusted to a shorter period of time.



The Sample time is set in minutes and seconds and the Cycle time is set in hours and minutes. Lakewood Instruments recommends that you consult your water treatment professional for more information on using these settings.

To configure the Blowdown relay for Sample/Cycle mode:

BOILER METHODS:  
2 SAMPLE/CYCLE

- In the BOILER METHODS screen, select "2" **SAMPLE/CYCLE**. The Sample Time screen will appear.

SAMPLE TIME=  
MM:00 SS:00

- In the Sample Time screen, use the number keys to input a minutes value, press "**ENT**", and use the number keys to enter a seconds value and press "**ENT**" to go to the Cycle Time screen. **Note:** The maximum time setting is 59 minutes and 59 seconds.

CYCLE TIME=  
HH:00 MM:00

- In the Cycle Time screen, use the number keys to input an hours value, press "**ENT**", and use the number keys to enter a minutes value and press "**ENT**". **NOTE:** The maximum allowed time is 17 hour and 59 minutes.

#### 6.4.2.1.3.3 SAMPLE HOLD

---

In the **Sample Hold** boiler applications, the controller will sample the water on a timed basis and then control based on a conductivity setpoint just like in the Sample/Cycle method above but with an added Hold feature.

The Blowdown relay will energize for a user selected time called the **Sample Time**. At the end of the Sample Time the Blowdown relay will turn off and the controller will go into a 30 second **Hold Time**. The Hold Time allows time for the sample to stop flashing before actually reading the conductivity value. At the end of the Hold Time, the controller will go into a **Reading Time** of 15 seconds. At the end of the Reading Time, the controller will compare the conductivity reading to the setpoint. If the conductivity is higher than the setpoint, the controller will go into a user selected **Blow to Resample Time** and re-energize the Blowdown relay to repeat the above sequence. Once the setpoint is satisfied the controller will keep the Blowdown relay turned off for a user selected time called the **Cycle Time**. At the end of the Cycle Time the Blowdown relay will once again go into the Sample Time and repeat the above sequence.

The sample time is set in minutes and seconds and the cycle time is set in hours and minutes. Lakewood Instruments recommends that you consult your water treatment professional for more information on using these settings.

To configure the Blowdown relay for Sample Hold mode:

**BOILER METHODS:  
3 SAMPLE HOLD**

- In the BOILER METHODS screen, select "3" **SAMPLE HOLD**. The Sample Time screen will appear.

**SAMPLE TIME=  
MM:00 SS:00**

- In the Sample Time screen, use the number keys to input a minutes value, press "**ENT**", and use the number keys to enter a seconds value and press "**ENT**" to go to the Cycle Time screen. **Note:** The maximum time setting is 59 minutes and 59 seconds.

**CYCLE TIME=  
HH:00 MM:00**

- In the Cycle Time screen, use the number keys to input an hours value, press "**ENT**", and use the number keys to enter a minutes value and press "**ENT**". **NOTE:** The maximum allowed time is 17 hour and 59 minutes.

**BLOW TO RESAMPL=  
MM:00 SS:00**

- In the Blow to Resample screen, use the number keys to input a minutes value, press "**ENT**", and use the number keys to enter a seconds value and press "**ENT**". **NOTE:** The maximum allowed time is 59 minutes and 59 seconds.

A typical **Sample Time** is 1 to 2 minutes with a Cycle time of up to 17 hours and 59 minutes. A short sample time is desired to prevent excessive loss of water and heat. Once the sample time is set, it should never have to be changed again.

The **Cycle Time** will need to be adjusted based on the steaming rate and make-up water quality. If using Sample/Cycle control and the conductivity does not rise to the setpoint, the Cycle time is probably set for too short of a time and will need to be adjusted to a longer period of time. If the conductivity is always above the setpoint, the Cycle time is probably set at too long of a time and will need to be adjusted to a shorter period of time.

The **Blow to Resample Time** is user selectable and is designed to allow the user to set the amount of time the blowdown relay will be re-energized for when the conductivity is higher than the setpoint after a sample is taken.

#### 6.4.2.1.4 BALL VALVE DELAY

---

Motorized ball valves require a few seconds to open and close. If the valve is commanded to close before it completes the process of opening, it may enter a state where it is half-open. The ball valve delay feature prevents this from occurring. To use this feature, determine how many seconds it takes to open and close the valve. Use the longest time and round up 1 second. Use this value as your Ball valve delay time. This delay time will also be observed when manually operating the BLOWDOWN relay.

#### 6.4.2.2 Configuring Relays 2 and 3

---

Both relays can be configured to operate based on: Disabled, Setpoint, Water Meter, Percent of blowdown, Percent of Time, or by Alarm. From the **WHICH RELAY?** screen select either relay #2 or relay #3. When relay 2(3) is selected for programming the **RELAY OPTIONS** screen will appear. The asterisk (\*) next to one of the options tells you how that relay is currently configured to feed. Use the **↑** and **↓** keys to view all of the relay options.

RELAY 2 (3) OPTIONS  
1 DISABLED

- 1 DISABLED
- 2 SETPOINT
- 3 WATER METER
- 4 % BLOWDOWN
- 5 % OF TIME
- 6 ALARM RELAY

##### 6.4.2.2.1 Disabled

---

Relays 2 and 3 can be disabled. When a relay is disabled, it will not energize automatically.

- From the **RELAY OPTIONS** screen press “1” **Disabled** to disable the relay.

### 6.4.2.2.2 By Setpoint

---

To set up a relay to operate based on a setpoint:

- Press or select “2” **SETPOINT**. The following screen will appear.

<b>BASED ON SETPT 1 SETPT VALUES</b>	1 SETPT VALUES 2 WHEN TO FEED
--	----------------------------------

#### 6.4.2.2.2.1 SETPOINT

---

In the **SETPT VALUES** screen you will set the **SETPOINT**, the **DEADBAND** and the amount of time for the **TIMEOUT** alarm.

The **SETPOINT** is the conductivity value at which you want the relay to operate. Check with your water treatment engineer to determine the conductivity setpoint for your system needs.

<b>WARNING: THE SETPOINT AND DEADBAND VALUES FOR THIS RELAY SHOULD BE SET AT THE SAME VALUES AS THE BLOW RELAY TO PREVENT OVER OR UNDER FEEDING OF CHEMICAL.</b>
--

From the **BASED ON SETPT** screen follow these instructions to establish the relay’s setpoint:

- Press “1” or highlight **SETPT VALUES** and press “**ENT**”.

<b>SETPOINT= 4500 <math>\mu</math>S</b>
---

- Use the keypad numbers to enter the proper conductivity setpoint and press “**ENT**”. When finished, you will automatically be prompted to set the deadband.

#### 6.4.2.2.2 DEADBAND

---

After the setpoint is established, the controller's deadband must also be set. "**Deadband**" refers to the amount of conductivity above and below the setpoint—a range within which the controller will not react. Due to continuous fluctuations in the conductivity level, it is necessary to have this deadband range or stable readings will be difficult to obtain. The Deadband should be a small percentage of the setpoint. Half the deadband amount will be automatically put above the setpoint, and the other half below it.

For example, a conductivity setpoint of 1,000  $\mu\text{S}$  with a deadband of 100  $\mu\text{S}$  would result in the relay turning on at 1,050  $\mu\text{S}$  and turning off at 950  $\mu\text{S}$ .

DEADBAND=  
000100  $\mu\text{S}$

- Use the keypad numbers to enter the proper deadband setpoint and press "**ENT**". When finished, you will automatically be switched to the **TIMEOUT** alarm screen.

#### 6.4.2.2.3 Timeout

---

The **TIMEOUT** alarm is designed to prevent overfeeding chemicals in case of a problem in the blowdown system such as, a clogged strainer or the blowdown valve did not open. The relay timeout function is an alarm feature that is displayed on the 150 series display process screen and **it will turn off the relay**. If a relay is configured as an alarm relay, the **TIMEOUT** alarm will energize the alarm relay. To disable the timeout function, simply program 0 hours, 0 minutes.

TIMEOUT=  
00:00

- Use the keypad numbers to enter the time in hours and minutes before this alarm will appear and press "**ENT**".

#### 6.4.2.2.2.4 When to feed

---

The relay can be configured to operate either **above the setpoint** or **below the setpoint**. When the relay is configured to operate **above the setpoint**, the relay will turn on when the conductivity rises above the setpoint plus one-half of the deadband. When configured to operate **below the setpoint**, the relay will turn on when the conductivity falls below the setpoint minus one-half of the deadband.

- In the **BASED ON SETPT** screen, press "2" or highlight **WHEN TO FEED** and press "ENT".

WHEN TO FEED  
1\*ABOVE SETPT

- In the **WHEN TO FEED** screen, select either "1" **ABOVE SETPT** or "2" **BELOW SETPT**. Then press any key.

#### 6.4.2.2.3 By Water Meter

---

Relays 2 and 3 can be configured to operate for a specified amount of time based on a specified amount of flow through the water meter input. The water meter total is used to activate the relay.

- From the **RELAY OPTIONS** screen press "3" **WATER METER**.
- Use the keypad to enter the amount of flow before the relay is activated. Press "ENT".
- Enter the amount of time that the relay will be activated. This time is in minutes and seconds. Press "ENT".

#### 6.4.2.2.4 By Percent of Blowdown Time

---

Relays 2, and 3 can be activated by a percent of the time that the blowdown was on. The relay will activate after the blowdown shuts off. For example, if 50% is entered and the blowdown relay is on for 10 minutes, the relay will be energized for 5 minutes.

- From the **RELAY OPTIONS** screen, press "4" **% BLOWDOWN**.
- Use the keypad to enter a percent of blowdown time to activate this relay. Press "ENT".

#### 6.4.2.2.5 By Percent of Time

---

The Percent of Time feature allows you to feed chemical strictly based by a percent of time. This relay control scheme works in patterns of 20-second time blocks. A relay is on for some multiple of 20 seconds and off for some multiple of 20 seconds. Below is a chart showing some of the operation times for Percent of Time.

Percent	On Time	Off Time
1%	20 Sec	<b>1980 Sec (33m)</b>
5%	20 Sec	<b>380 Sec (6m20S)</b>
10%	20 Sec	<b>180 Sec (3 m)</b>
25%	20 Sec	<b>60 Sec</b>
33%	20 Sec	<b>40 Sec</b>
50%	20 Sec	20 Sec
66%	<b>40 Sec</b>	20 Sec
75%	<b>60 Sec</b>	20 Sec
90%	<b>180 Sec (3 m)</b>	20 Sec
95%	<b>380 Sec (6m20S)</b>	20 Sec
99%	<b>1980 Sec (33m)</b>	20 Sec

Note: In the case of “33%”, once every 66 minutes, the “off” time would extend an extra 20 seconds to make up for the accumulation of the odd % value vs. a 24 hour clock, since the percent of time is based on a 24HR clock in 20 second increments. The same could be said for the “66%” timer, except it will remain “ON” for the additional 20 seconds every 66 minutes.

To determine the total amount of chemical fed over a 24 hour period, multiply the percent of time by the number of hours a day that your controller is operating, then multiply by your chemical pump flow rate per hour.

For example:

We select 10% of the time, our controller operates 24 hours a day and our chemical pump flow rate is 1 gallon per hour.

$$10\% \times \frac{24 \text{ hours}}{\text{Day}} \times \frac{1 \text{ gallon}}{\text{Hour}} = \frac{2.4 \text{ Gallons}}{\text{Day}}$$

- From the **RELAY OPTIONS** screen press **"5" PERCENT OF TIME**.
- Use the keypad to enter the percentage of time desired. Press **"ENT"**.

#### 6.4.2.2.6 As an Alarm Relay

---

Relays #2 and 3 can be configured as alarm relays. Any alarm will cause the relay to activate. These alarms include: HIGH Conductivity, LOW Conductivity, BLOW ALARM TIMEOUT, RELAY #2 TIMEOUT, RELAY #3 TIMEOUT, and the NO FLOW alarm.

- From the **RELAY OPTIONS** screen press "6" **ALARM RELAY**. The controller will respond with the following screen.

ACTIVE ON ANY ALM  
press any key

**NOTE:** A relay that is configured as an alarm relay will be activated any time any alarm including the "NO FLOW" alarm is present.

#### 6.4.3 Alarms

---

The Model 150 is equipped with both high and low conductivity alarms. This menu option allows you to program the specific values for these alarms. When a conductivity alarm is received, it will appear as a flashing message in the alarm screen and any configured alarm relays will be activated. Consult your water treatment specialist when determining the proper High and Low Alarm values for your system.

To get to the alarm settings:

- From the **MAIN MENU** press "3" **ALARMS**.

HIGH ALM= 5000 $\mu$ S  
LOW ALM= 100 $\mu$ S

- Use the keypad to enter a value for the high alarm. Press "ENT".
- Use the keypad to enter a value for the low alarm and press "ENT".



## 6.4.4 Water Meter

---

The model 150 controller will work directly with the following types of meters: dry contacting head meters, Seametrics open collector output meters, paddle wheel meters such as the Signet 2535 and 2540, and the Autotrol 1 inch and 2 inch turbine meters. Contact Lakewood Instruments for other types of water meters.

To get to the water meter configuration screen:

- From the **main menu**, press "4" **WATER METERS**.

MTR1: GAL/LTR?  
1 \*GALLONS

1 GALLONS  
2 LITERS

- The water meter can be configured for gallons or liters. Press "1" for **GALLONS** or press "2" for **LITERS**.
- This will take you to the **WATER METER TYPES** screen as shown below.

WATER MTR TYPES  
1 CONTACT HEAD

1 CONTACT HEAD  
2 PADDLE WHEEL  
3 AUTOTROL 1 IN  
4 AUTOTROL 2 IN

- Use the keypad to select the type of water meter that you are using.

If **CONTACTING HEAD** is selected:

- You will be taken to the **GALLONS OR LITERS PER CONTACT** screen. Use the keypad to enter the number of gallons or liters per contact for your specific meter then press "ENT". You will then be asked if you want to reset the meter count to zero. Press "1" for **YES** or press "2" for **NO**.

If **PADDLE WHEEL** is selected:

- You will be taken to the **K-FACTOR** screen. Use the keypad to enter the K-factor for your particular water meter then press "ENT". You will then be asked if you want to reset the meter count to zero. Press "1" for **YES** or press "2" for **NO**.

If **AUTOTROL TURB 1 IN.** is selected:

- You will be asked if you want to reset the meter count to zero. Press "1" for **YES** or press "2" for **NO**.

If the **AUTOTROL TURB 2 IN.** is selected:

- You will be asked if you want to reset the meter count to zero. Press "1" for **YES** or press "2" for **NO**.

## 6.4.5 Set Up of the 4-20 mA Output

---

The model 150 has one 4-20 mA output that is configured for conductivity. To set up the 4-20 mA output:

- From the **Main Menu**, press "5" **4-20 mA OUT**.

There are three things that can be done from the **4-20 mA Out Setup** screen; set the 4-20 mA range, take manual control of the 4-20 mA output and calibrate the 4-20 mA output. Below is the **4-20 mA Setup** screen.



### 6.4.5.1 Set the 4-20 mA Range

---

The 4-20 mA output range must be set for the output to be useful.

- From the **4-20 mA OUTPUT** screen, press "1" **Set the 4-20 mA RANGE**.
- Use the keypad to enter a conductivity value for the 4-mA point. Press "ENT".
- Use the keypad to enter a conductivity value for the 20-mA point. Press "ENT".

### 6.4.5.2 Manual Control

---

Manual control is used to temporarily change the 4-20 mA output.

- From the **4-20 mA Setup** screen, press "2" **MANUAL CONTROL**.
- Use the **up** and **down** arrow keys to raise or lower the 4-20 mA output. To exit this screen and restore automatic control of the 4-20 mA output press "CLR".

### 6.4.5.3 Calibrate the 4-20 mA Output

---

The 4-20 mA needs to be calibrated to the actual output to be accurate. A milliamp meter is necessary to calibrate the 4-20 mA output. Connect the milliamp meter in-line with one leg of the 4-20 mA output. Refer to the drawing in the back of this manual for wiring instructions.

- From the **4-20 mA OUTPUT** screen, press "3" **CALIBRATE**.
- Use the keypad to enter the milliamp reading from the milliamp meter for the 4-mA point. Press "ENT".
- Use the keypad to enter the milliamp reading from the milliamp meter for the 20-mA point. Press "ENT".

## 6.4.6 System Setup Menu

---

The system setup menu is used to initialize the controller or calibration, and check the firmware version.

To reach the **SYSTEM SETUP MENU**:

- From the **MAIN MENU** press “**6**” **SYSTEM SETUP**. The following screen will appear.



### 6.4.6.1 Process Parameters

---

The Process Parameters screens allow the user to enable the Anti-Flashing feature and to enable or disable the conductivity input.

To reach the **PROCESS PARAMETERS MENU**:

- From the **SYSTEM SETUP MENU** press “**1**” **PROCESS PARMS**. The following screen will appear.

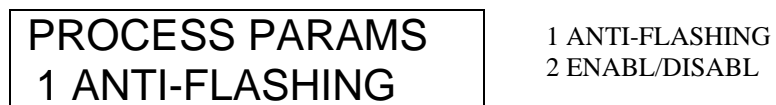

#### 6.4.6.1.1 Anti-Flashing

---

The anti-flashing menu selection inserts a damping circuit value into the conductivity circuit to slow down the rate of change of the conductivity when steam flashing is occurring.

To enable the anti-flashing feature:

- From the **Main Menu** press “**6**” **SYSTEM SETUP**.
- Press “**1**” **PROCESS PARMS**.
- Press “**1**” **ANTI-FLASHING**.
- Press “**1**” **YES** to enable anti-flashing, press “**2**” **NO** to disable anti-flashing.

#### **6.4.6.1.2 Enable/Disable the Conductivity Input**

---

The Model 150 can be used with or without the conductivity input. If conductivity is not being used, disable the conductivity input.

- From the **Main Menu** press **"6" SYSTEM SETUP.**
- Press **"1" PROCESS PARAMETERS.**
- Press **"2" ENABL/DISABL.**
- Press **"1" YES** to enable the conductivity input or press **"2" NO** to disable the conductivity input.

**NOTE:** When the conductivity is disabled, the Process screen will display the status of the three relays in the top section of the display in place of the conductivity reading.

#### **6.4.6.2 Initialize**

---

Initialization restores the factory default settings to the controller. The whole controller can be initialized or just the calibration. It is suggested that you initialize the whole controller before you program the controller for the first time. This will clear any random settings that may be in the controller. To do so, follow these instructions:

- From the **Main Menu**, press **"6" SYSTEM SETUP.**
- Press **"2" INITIALIZE.**
- Press **"2" WHOLE CTRLR.** You will then be asked **"ARE YOU SURE?"**. Press **"1" for YES** or press **"2" for NO.**

To initialize just the calibration:

- Press **"1" CALIBRATION** instead of **"2" WHOLE CONTROLLER** in the procedure above. The same message will appear.

#### **6.4.6.3 Firmware Version**

---

Sometimes it is necessary to verify the firmware version of the controller for troubleshooting purposes. To get to the firmware version:

- From the **Main Menu**, press **"6" SYSTEM SETUP.**
- Press **"3" FIRMWARE VER.**
- The firmware version will be displayed along with a checksum value. The checksum value is used to verify that the program has not been corrupted. To exit this screen, press any key.

### 6.4.7 Setting the Clock

---

The clock uses the 24 hour or military time. 06:00:00 is 6 a.m. 18:00:00 is 6 p.m. To set the clock:

- From the **Main Menu** press "7" **CLOCK**. The following screen will appear:

WED 24 FEB '10 15:02:41
----------------------------

- Press "**PRO**" to change the clock settings. The day will start flashing.
- Use the up and down arrow keys to change the day of the week. Press "**ENT**".
- Use the number keys to change the date. Press "**ENT**".
- Use the arrow keys to change the month. Press "**ENT**".
- Use the number keys to change the year. Press "**ENT**".
- Use the number keys to change the hour. Press "**ENT**".
- Use the number keys to change the minutes. Press "**ENT**".
- Use the number keys to change the seconds. Press "**ENT**".
- Press "**CLR**" to exit this screen.

You must press "**ENT**" all the way through this menu for the settings to take affect.

## 7.0 Maintenance

---

Periodic maintenance is required to ensure trouble free operation of the model 150 controller. The following sections cover the required maintenance.

### 7.1 Sensor Maintenance

---

Routine maintenance is necessary in order to maximize the efficiency and accuracy of your sensor. Clean the electrode end of the conductivity sensor at least once per month. Cleaning of the conductivity sensor may need to be performed more frequently if it is in a high fouling environment.

- Remove power from the controller and shut off the sample flow.
- Remove the sensor from its plumbing.
- Use a wire brush to lightly brush the sensor tips. Do not use cloth to clean the sensor tips. Cloth has oils that will foul the sensor.
- If there is oil on the sensor tips, use isopropyl alcohol to clean the tips.
- If there is scale on the sensor tips use a 10% Muriatic or HCL acid to clean the sensor.
- Wash the sensor off with tap water.
- Install the sensor in its plumbing.
- Restore sample flow and check for leaks.
- Restore power to the controller.
- Perform a calibration of the conductivity.
- Verify operation before leaving area.

## 7.2 Replacing the Fuses

---

The Model 150 contains a two 5 x 20 mm, European-style fuses. Replacement fuses must be a Schurter 0034.1526, Littlefuse 217.010, or equivalent 10A, 250V, fast blow type for Fuse F1 and a Littlefuse 218.100, Schurter 0034.3107, or equivalent 100mA, slow blow for Fuse F2. If a fuse is blown, the display will be blank when the unit is connected to power. Refer to the troubleshooting section of this manual for more information about blank displays.

115/230VAC power selector switch

100mA, 250V, slow blow fuse

10A, 250V, fast blow fuse

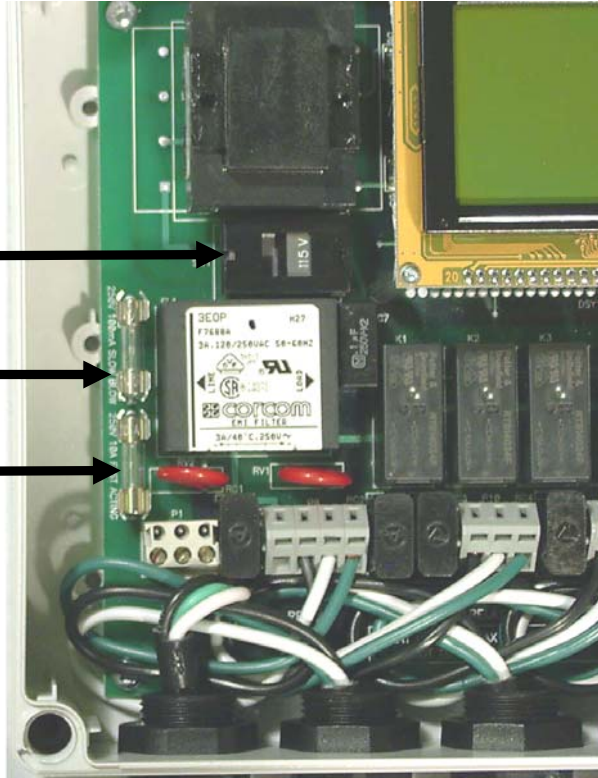

## 8.0 Troubleshooting

### 8.1 Error Messages

This section discusses some of the more common questions with the Model 150. These notes are not intended to be all-inclusive—only to cover the most common situations. If you have other questions or are need support, contact the Lakewood Instruments Technical Service Department toll free at (800) 228-0839.

PROBLEM	WHAT THIS MEANS	CORRECTIVE ACTION
{Alarm Flashing} “CONDUCTIVITY HIGH” OR “CONDUCTIVITY LOW”	Conductivity is too high or low with respect to the high or low alarm setpoint.	<ol style="list-style-type: none"> <li>1. See problem “RELAY TIMEOUT”.</li> <li>2. Check the chemical pump operation.</li> <li>3. The chemical drum is empty.</li> <li>4. Check the High or Low Alarm Value.</li> <li>5. Check relay setpoints and deadbands.</li> <li>6. Insure the system is not overflowing.</li> </ol>
Water meter not accumulating.	<p>There may be a problem with the wiring or the reed switch in the meter may be bad.</p> <p>For water meters other than the contacting head type, check the manufacturer’s user manual for that particular water meter.</p>	<ol style="list-style-type: none"> <li>1. Approximately 5 volts DC should be present at the input terminal when the water meter contact is closed. That should change to zero VDC when the contact opens. Check these voltages and for correct wiring.</li> <li>2. Is the controller configured for your type of water meter?</li> </ol>
Display is blank.	There may be a problem with the incoming power, the fuses or the circuit board. Open the front panel to troubleshoot.	<ol style="list-style-type: none"> <li>1. Check the fuse F1. Replace with 5 x 20 mm, 10A, 250V, fast blow fuse.</li> <li>2. Check the fuse F2. Replace with 5 x 20 mm, 100mA, 250V, slow blow fuse.</li> <li>3. Does the unit have power?</li> <li>4. If there is power to terminals AC and ACC on P1, call Lakewood Instruments Technical Service for more information.</li> </ol>
“NO FLOW” alarm.	Flow input switch is not closed.	<ol style="list-style-type: none"> <li>1. The flow switch float may be stuck or no flow is present.</li> <li>2. Flow switch may be bad. Replace reed switch in plumbing assembly.</li> </ol> <p>If no flow switch is used, a jumper wire should be installed across the flow switch input. Removing the jumper disables the relay outputs for relays 2 and 3 but, does not affect the Blow relay.</p>



PROBLEM	WHAT THIS MEANS	CORRECTIVE ACTION
<p><b>{Alarm Flashing}</b>  <b>“RELAY TIMEOUT”.</b></p>	<p>This indicates that the controller has been trying to operate a relay for longer than the user-programmed time and is unable to reach the setpoint.</p>	<ol style="list-style-type: none"> <li>1. Check for proper operation of the pump or valve. Use the manual relay control to help.</li> <li>2. Check the relay configuration and verify settings.</li> <li>3. Check chemical levels in the drums or totes.</li> <li>4. Verify operation of water meters.</li> <li>5. Momentarily shut off system flow to reset alarms.</li> </ol>
<p><b>Motorized ball valve functions, but will not remain “open” or “closed” as expected.</b></p>	<p>The motorized ball valve is not indicating to the 150 that it has actually reached the open or closed position.</p>	<p>Adjust the limit switch for the motorized ball valve.</p>

## 9.0 Factory Service

---



Technical Support for Lakewood Instruments can be reached by calling (800) 228-0839 or faxing (414) 355-3508, Monday through Friday, 7:30 a.m. - 4:30 p.m. CST.

***NOTE: IF YOU CALL FOR TROUBLESHOOTING HELP, PLEASE HAVE THE MODEL NUMBER, SERIAL NUMBER, AND ANY OPTIONS PERTAINING TO YOUR UNIT AVAILABLE FOR REFERENCE.***



Mail and returns should be sent to:

**Lakewood Instruments  
7838 North Faulkner Road  
Milwaukee, WI 53224 USA**

When any merchandise is to be returned to the factory, please call and obtain a Return Goods Authorization (RGA) number and have the following information available:

- Customer's name, address, telephone and fax numbers (shipping and billing).
- A hard copy purchase order number for cases where repairs or parts are required that are not under warranty.
- A contact person's name and telephone number to call if the equipment is beyond repair or to discuss any other warranty matter.
- Equipment model and serial numbers.
- Reason for return, e.g., repair, warranty, incorrect part, etc.

We will then fax to your attention an RGA form that must accompany the returned item.

***NOTE: THE RGA NUMBER MUST BE CLEARLY WRITTEN ON THE OUTSIDE OF THE PACKAGE(S) BEING RETURNED.***

**ANY ITEMS SENT BACK TO THE FACTORY  
WITHOUT AN RGA NUMBER WILL BE REFUSED  
AND RETURNED TO SENDER**

## **Service Guide**

When calling Lakewood Instruments, please have your controller's complete model number and serial number available, together with the firmware version so that the Technician can better assist you.

Refer to the Ordering Information section of this manual for part numbered replacement parts.

Write your controller's complete model number, serial number, and firmware version here so that you will have them available if you wish to contact a Lakewood Instruments technician.

Model Number:

Serial Number:

Firmware Version:

## 10.0 Drawings

---

NOTES:

⚠ MAXIMUM DISTANCE FROM SENSOR TO CONTROLLER IS 20 FEET

REVISION		REVISION HISTORY			
DWG	PART	DESCRIPTION	ECO	DATE	APV DATE
A	A	RELEASE	1011B	PSG 3/3/10	
B	A	CHANGED CABLE TO 2 WIRE	10127	PSG 5/5/11	

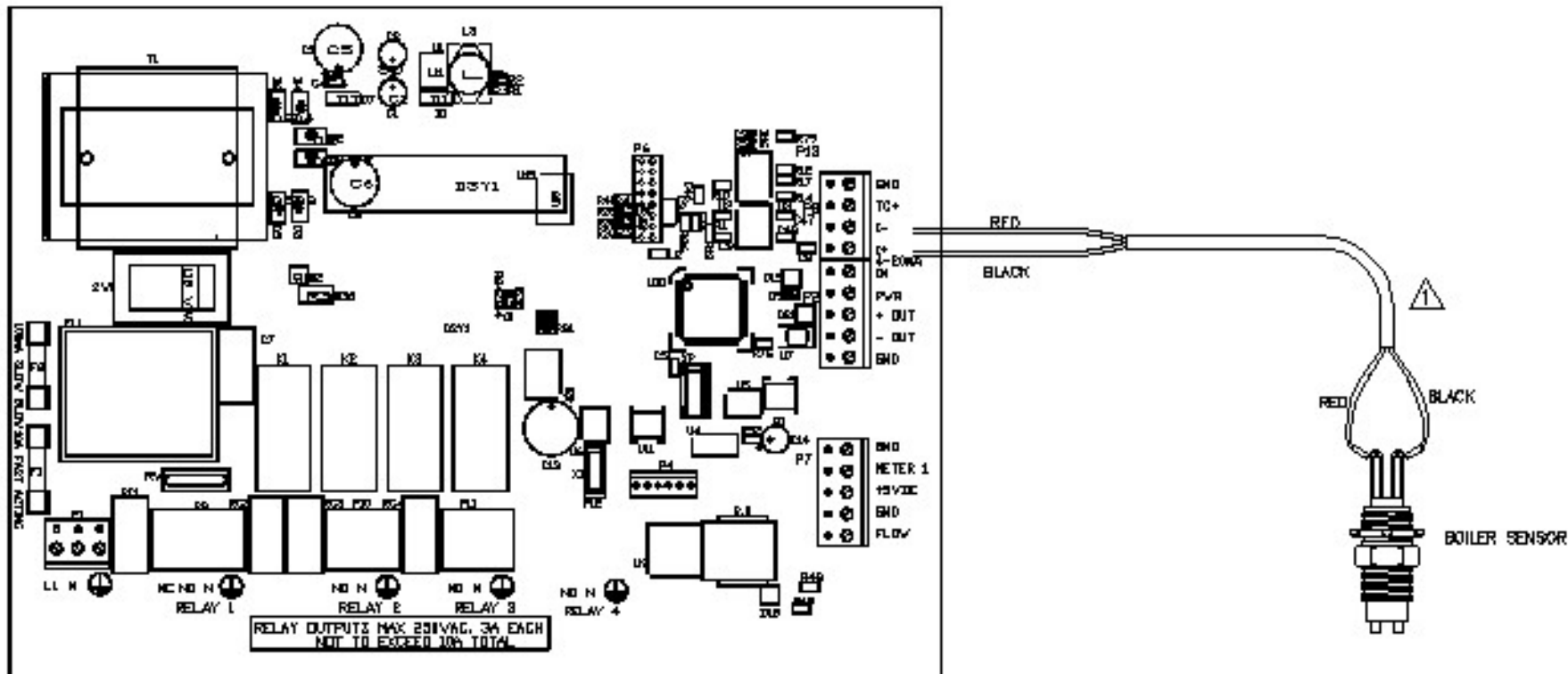

<p><b>NOTICE ON REPRODUCTIONS</b>          NO REPRODUCING, THE DESIGN, AND THE PATENTS IT CONTAINS ARE THE PROPERTY OF          LAKWOOD INSTRUMENTS (U.S.) INC. AND LOCATED SOLELY ON THE BOARDSHIPS SHOWN.          REPRODUCTION OF THIS DRAWING FOR ANY PURPOSES, WITHOUT THE WRITTEN PERMISSION,          SHALL BE HELD TO BE STRICTLY PROHIBITED. THE PENALTY THEREFOR SHALL BE ASSESSMENT          TO THE LIMITS OF THE LAW.</p>		<p><b>Lakewood INSTRUMENTS</b></p>	
<p><b>DIMENSIONS AND TOLERANCES UNLESS OTHERWISE SPECIFIED</b></p>		<p>TITLE  <b>BOILER SENSOR WIRING FOR M150</b></p>	
<p>MATERIAL</p>	<p>TOLERANCES UNLESS SPECIFIED          FRACTIONS: ±0.005          DECIMALS: ±0.005          ANGLES: ±0.005</p>	<p>FINISH</p>	<p>DATE 3-5-10</p>
<p>PROJECT</p>	<p>APVD</p>	<p>DATE</p>	<p>DATE</p>
<p>LIBRARY</p>	<p>DATE</p>	<p>DATE</p>	<p>DATE</p>
<p>SIZE <b>B</b></p>		<p>1269089</p>	<p>REV A</p>
<p>SCALE</p>		<p>SHEET</p>	<p>DWG NO          1269089_1b</p>

NOTES: UNLESS OTHERWISE SPECIFIED;

1. ORIFICE UNIONS MUST BE INSTALLED TO PREVENT STEAMFLASH. REFER TO USER MANUAL 1106840 FOR PROPER ORIFICE SIZING.

2. SENSOR MUST BE MOUNTED HORIZONTALLY AND MUST BE AT LEAST 2 FEET BELOW THE WATER LEVEL OF THE BOILER. THE DISTANCE FROM THE SENSOR TO THE ORIFICE UNION MUST BE 5 FEET OR LESS.

3. THE 150 MUST BE LOCATED WITHIN 20 FEET OF THE BOILER SENSOR AND AS FAR FROM HEAT AS POSSIBLE.

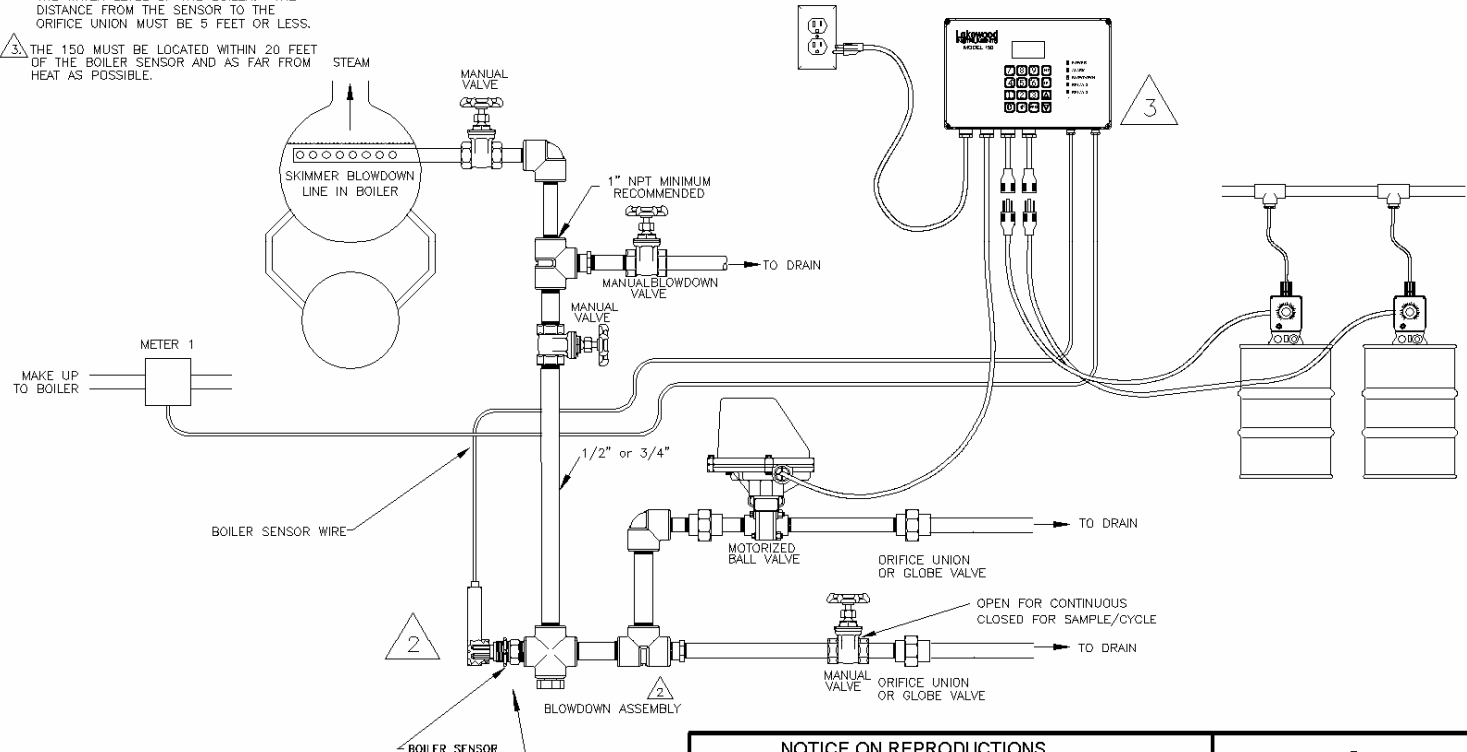

REVISION		REVISION HISTORY			
DWG	PART	DESCRIPTION	ECO	DWN/DATE	APVD/DATE
A	A	RELEASE	10118	PSG 03/05/2010	

**NOTICE ON REPRODUCTIONS**  
 THIS DRAWING, THE DESIGN, AND THE PATENTS IT COVERS ARE THE PROPERTY OF LAKEWOOD INSTRUMENTS LLC. THEY ARE LOANED MERELY ON THE BORROWER'S EXPRESS AGREEMENT THAT THEY WILL NOT BE REPRODUCED, COPIED, LOANED, EXHIBITED, NOR USED EXCEPT IN THE LIMITED WAY AND THE PRIVATE USE PERMITTED BY WRITTEN CONSENT GIVEN BY THE LENDER TO THE BORROWER.



DIMENSIONING AND TOLERANCING PER ASME Y14.5M-1994	
MATERIAL	TOLERANCES UNLESS NOTED
	DECIMALS ANGLES
	XX ± ±
	XXX ± SURFACE

TITLE: INSTALLATION LAYOUT: CONTINUOUS, SAMPLE / CYCLE, OR SAMPLE / HOLD, MODEL 150

FINISH	DWN	PSG	DATE	3/5/10
	CHKD		DATE	
PROJECT:	APVD		DATE	
LIBRARY:				

SIZE	B	THIRD ANGLE	PN	1269089	REV	A	
SCALE	NTS	SHEET	1/1	DWG NO	1269089_2a	REV	A

SENSOR MUST BE MOUNTED HORIZONTALLY AND MUST BE AT LEAST 2 FEET BELOW THE WATER LEVEL OF THE BOILER. THE DISTANCE FROM THE SENSOR TO THE ORIFICE UNION MUST BE 5 FEET OR LESS.

NOTES: UNLESS OTHERWISE SPECIFIED;  
 ⚠ IF NO FLOW SWITCH IS USED, SHORT OUT PINS 1 & 2 WITH WIRE.

REVISION HISTORY					
REV	DESCRIPTION	ECO	DWN	DATE	APVD
A	RELEASE	10118	PSG	3/5/10	

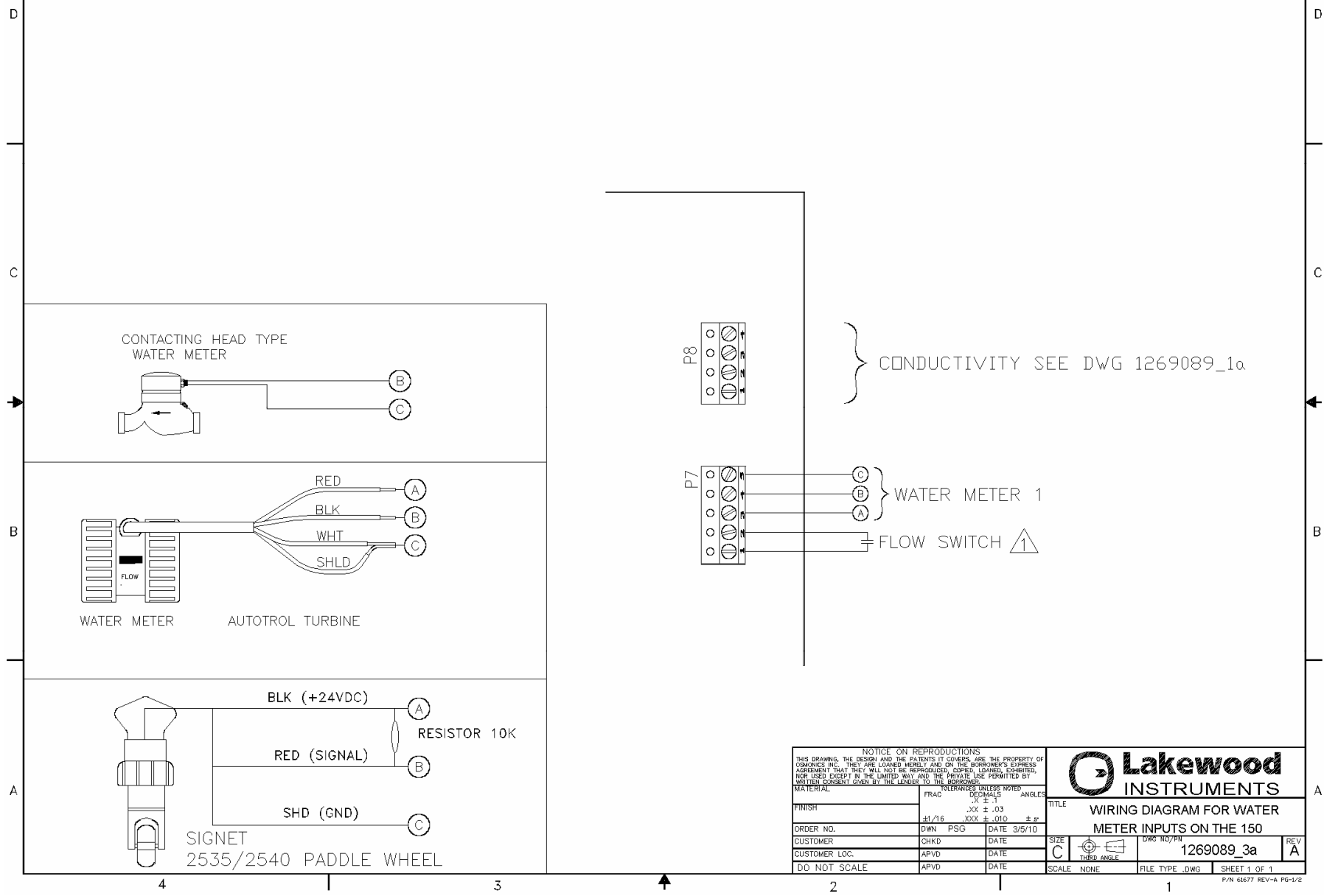

NOTICE ON REPRODUCTIONS  
 THIS DRAWING, THE DESIGN AND THE PATENTS IT COVERS, ARE THE PROPERTY OF  
 LAKWOOD INC. THEY ARE LOANED MERELY AND ON THE BORROWER'S EXPRESS  
 AGREEMENT THAT THEY WILL NOT BE REPRODUCED, COPIED, LOANED, EXHIBITED,  
 NOR USED IN ANY MANNER IN THE LIMITED WAY AND THE PRIVATE USE PERMITTED BY  
 WRITTEN CONSENT GIVEN BY THE LENDER TO THE BORROWER.

MATERIAL	TOLERANCES UNLESS NOTED	DECIMALS	ANGLES
FINISH	FRACTION	XX ± .1	
ORDER NO.	DWN PSG	.XX ± .03	
CUSTOMER	CHKD	.1/16 .XXX ± .010 ± .5°	
CUSTOMER LOC.	APVD	DATE 3/5/10	
DO NOT SCALE	APVD	DATE	

**Lakewood INSTRUMENTS**

TITLE: WIRING DIAGRAM FOR WATER METER INPUTS ON THE 150

DWG NO./PIN: 1269089\_3a

REV: A

SCALE: NONE

FILE TYPE: .DWG

SHEET 1 OF 1

P/N 61677 REV-A PG-1/2

REVISION		REVISION HISTORY			
DWG	PART	DESCRIPTION	ECO	DWN/DATE	APVD/DATE
A	A	RELEASE	10118	PSG 3/3/10	

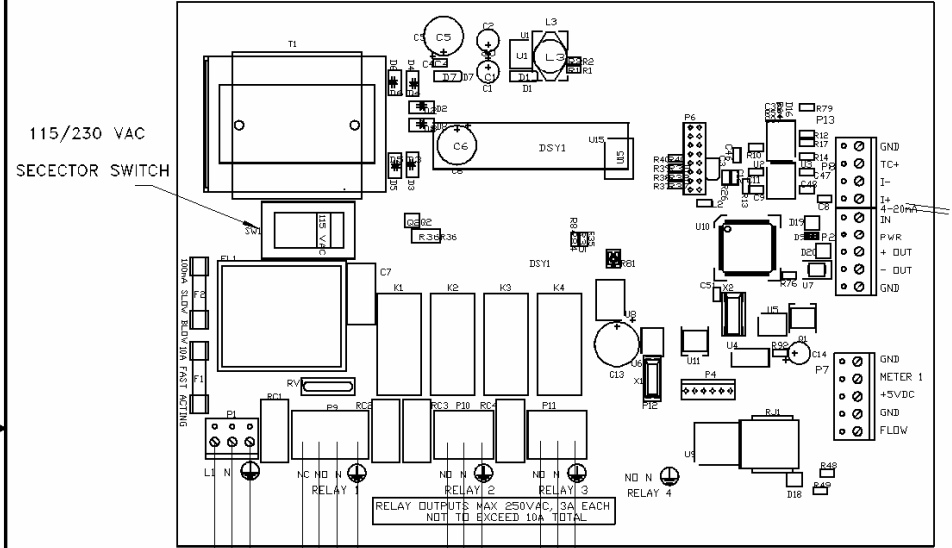

115/230 VAC / 50-60 Hz.  
(COM)  
(E GND)

RELAY1 HOT (NO)  
RELAY1 HOT (NO)  
(COM)  
(E GND)

RELAY2 HOT (NO)  
(COM)  
(E GND)

RELAY3 HOT (NO)  
(COM)  
(E GND)

RELAY4

MOTORIZED BALL VALVE OR SOLENOID VALVE

CHEM PUMPS / ALARM OUTPUTS

RELAY OUTPUTS: MAX 250VAC, 3A EACH  
NOT TO EXCEED 10A TOTAL

**NOTICE ON REPRODUCTIONS**  
THIS DRAWING, THE DESIGN, AND THE PATENTS IT COVERS ARE THE PROPERTY OF LAKEWOOD INSTRUMENTS LLC. THEY ARE LOANED MERELY ON THE BORROWER'S EXPRESS AGREEMENT THAT THEY WILL NOT BE REPRODUCED, COPIED, LOANED, EXHIBITED, NOR USED EXCEPT IN THE LIMITED WAY AND THE PRIVATE USE PERMITTED BY WRITTEN CONSENT GIVEN BY THE LENDER TO THE BORROWER.



DIMENSIONING AND TOLERANCING PER ASME Y14.5M-1994		TOLERANCES UNLESS NOTED	
MATERIAL	DECIMALS	ANGLES	SURFACE
	.X ±	±	±
	.XX ±		
	.XXX ±		

TITLE			
WIRING DIAGRAM FOR THE 150 POWER CONNECTIONS			
FINISH	DWN PSG	DATE 3-5-10	SIZE B
PROJECT:	CHKD	DATE	THIRD ANGLE
LIBRARY:	APVD	DATE	SCALE SHEET
PN 1269089		REV A	
DWG NO 1269089_5a		REV A	



NOTES:

⚠ FOR INTERNAL 24VDC JUMPER WIRE IS REQUIRED

REVISION		REVISION HISTORY			
DWG	PART	DESCRIPTION	ECO	DWDATE	APVD/DATE
A	A	RELEASE	10118	PSG 3/8/10	

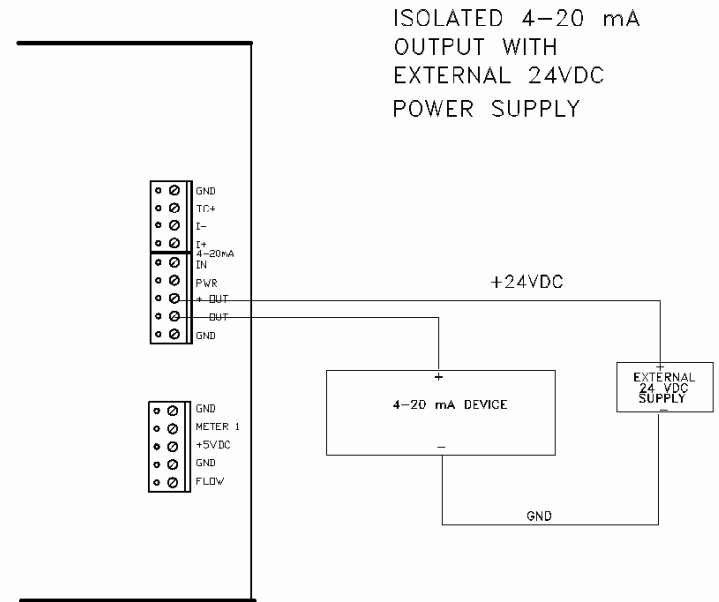
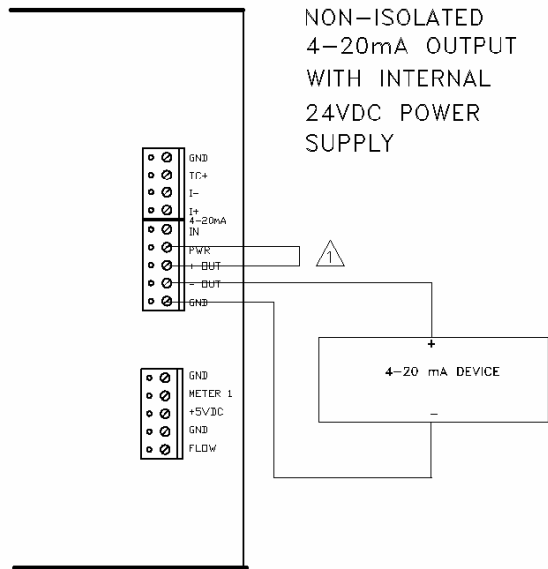

<p><b>NOTICE ON REPRODUCTIONS</b> THIS DRAWING, THE DESIGN, AND THE PATENTS IT COVERS ARE THE PROPERTY OF LAKEWOOD INSTRUMENTS LLC. THEY ARE LOANED MERELY ON THE BORROWERS EXPRESS AGREEMENT THAT THEY WILL NOT BE REPRODUCED, COPIED, LOANED, EXHIBITED, NOR USED EXCEPT IN THE LIMITED WAY AND THE PRIVATE USE PERMITTED BY WRITTEN CONSENT GIVEN BY THE LENDER TO THE BORROWER.</p>			
<p>DIMENSIONING AND TOLERANCING PER ASME Y14.5M-1994</p>		<p>TOLERANCES UNLESS NOTED</p> <p>DECIMALS            ANGLES</p> <p>XX ±                    ±</p> <p>XXX ±                  SURFACE</p>	
<p>MATERIAL</p>		<p>TITLE</p> <p>4-20mA WIRING FOR THE 150</p>	
<p>FINISH</p>	<p>DWN PSG    DATE 3-8-10</p> <p>CHKD        DATE</p>	<p>SIZE <b>B</b></p>	<p>PN 1269089</p> <p>REV <b>A</b></p>
<p>PROJECT:</p> <p>LIBRARY:</p>	<p>APVD        DATE</p>	<p>SCALE    SHEET</p>	<p>DWG NO 1269089_6a</p> <p>REV <b>A</b></p>





**For more information call toll free in the USA (800) 228-0839**

**Manufactured in the USA**

***LAKWOOD INSTRUMENTS***

*7838 North Faulkner Road, Milwaukee, WI 53224 USA  
Phone (800) 228-0839 • Fax (414) 355-3508  
<http://www.lakewoodinstruments.com>*