

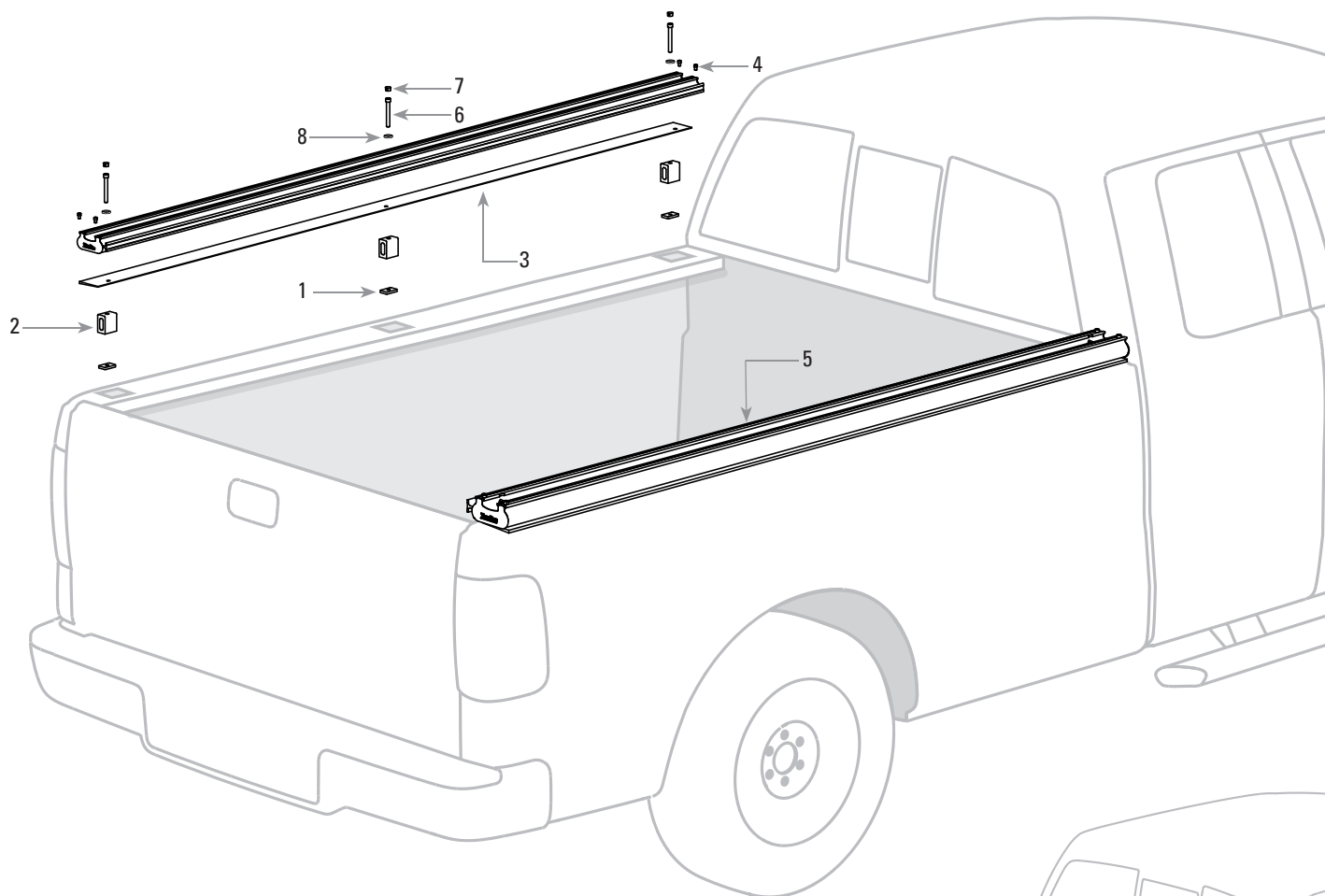

BASE RAIL ASSEMBLY



BASE RAIL ASSEMBLY:

Item	Description	Qty
1	Brass pocket nut	4/6
2	Rubber expansion block	4/6
3	Plastic wedge/shim	2
4	Safety bolt 3/8" long	8
5	Base rail (Left & Right)	2
6	Socket head cap screw 3" long	4/6
7	Plastic access plug	30
8	Nylon washer	6
9	1/8" rubber spacer (not shown) For trucks without stake pockets.	6

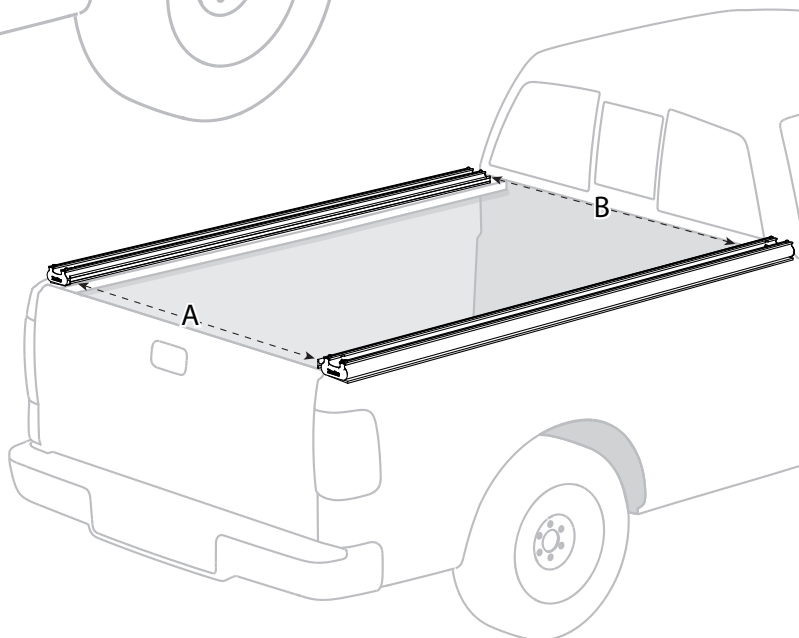

Note: Measurements "A" and "B" must be equal

BASE RAIL INSTALLATION

Trucks without bedliners

OVERVIEW:

TracRac installation is straightforward, and should take about an hour. You'll start by mounting the base rails to the truck, ensuring that they remain parallel and in plane. Then you'll assemble the overhead racks, sliding them onto the base rails.

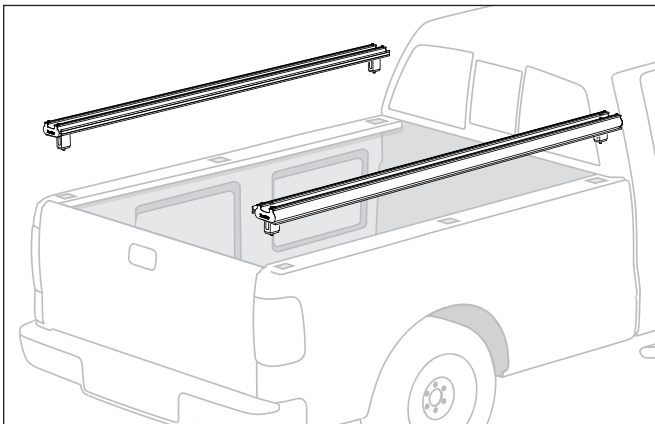

1. Verify that you have received the correct parts, and that the base rail part # corresponds to your pickup truck make, model, and year.
2. Locate the correct hole pattern in the base rails for your truck by referring to the enclosed base rail layout drawing. The holes will line up with the stakepockets.

Note: Some beds taper, so the truck bed side walls "curve" underneath the base rails – that's OK!

Note: Labels at the end of each base rail identify the front and side of the truck the rails must be placed on.

3. Use the plastic access plugs to cover the holes that do not correspond to your truck.

*Truck models not requiring plastic shims

Mfg. #	Description
21010	Ford Super Duty - Long Bed
21508	F-150 Super Crew
21510	Ford Super Duty - Short
21606	Nissan Titan Crew Cab
21607	Nissan Titan King Cab

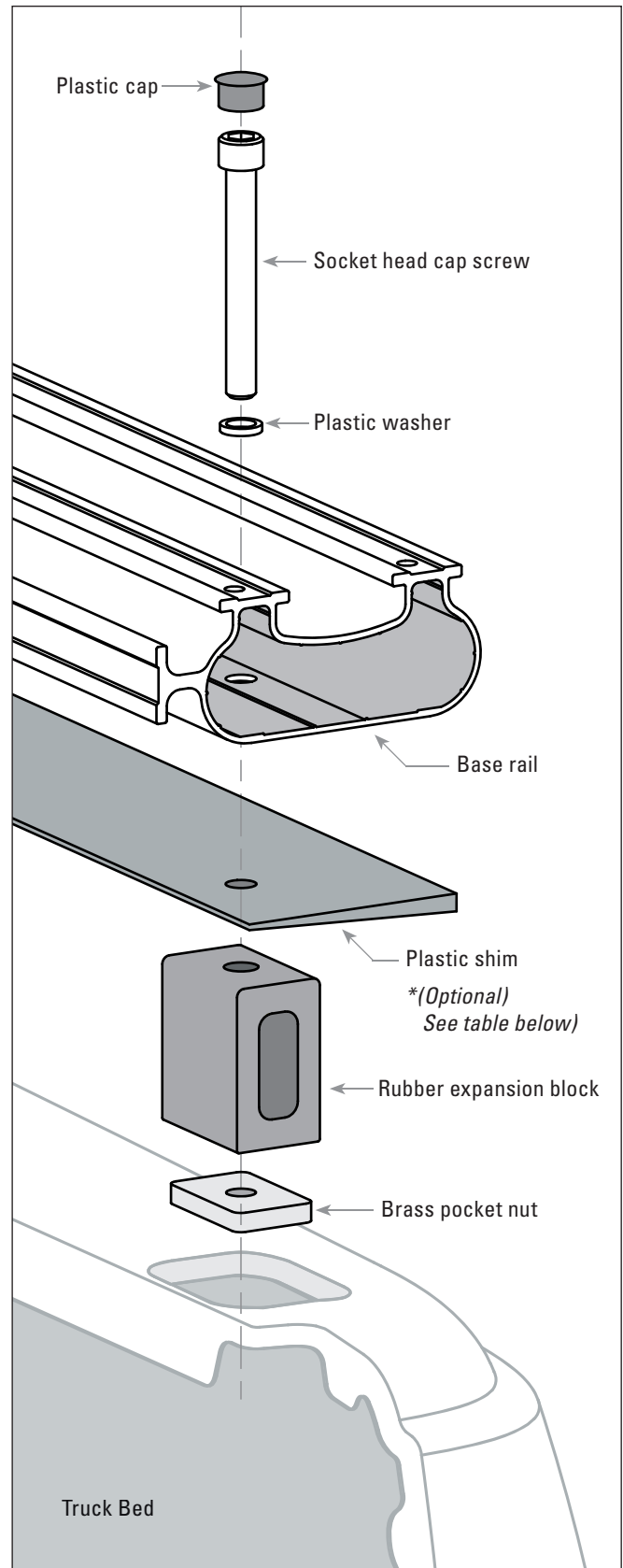

4. Line up the base rail and the plastic shim so that the holes line up – the thick side of the shim should face outwards. (*Certain truck models do not require the plastic shim. See table on page 5 for details.*) Insert one plastic washer onto each 3/8-16 x 3" socket head cap screw. Insert the socket head cap screws through the base rail holes, through the shim and through the rubber expansion blocks, *as shown below*. Hand tighten the brass pocket nuts just enough to hold the rubber expansion blocks in place against the shim (without compressing the rubber block).

Tip: Tape or glue the brass pocket nuts to the rubber expansion blocks before inserting them into the stake pockets of the truck. This will stop the nuts from dropping into the stake pockets if you ever need to loosen and remove the rails.

5. Insert the rubber block assembly into the stake pockets of the vehicle (the rubber blocks fit right into the stake pockets). Repeat the process for the other base rail.

NOTE: For trucks without stake pockets, refer to notes on page 7.

6. Base rails must be parallel and in plane.

Parallel (Straight): Before tightening, measure the inside width, from rail to rail, using the T-Tracks of each base rail at the same location front and rear. Measurements are to be equal within 1/16": adjust as required.

In plane (Flat): Use a straight edge or the crossbar to ensure base rails remain level. The straight edge should touch all four tracks, within 1/16". If not, adjust the shims, or use the supplied rubber tape strips to level out the base rails.

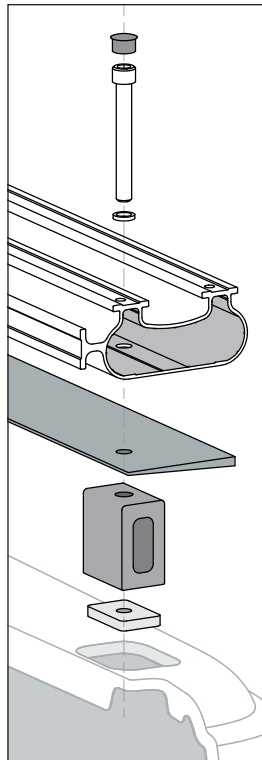

7. Partially tighten the block assemblies at the cab end of the truck, (left & right sides), using a 5/16" socket wrench on the ball point allen driver supplied. Press downwards to keep the rail in position as you tighten. (Note: The "ball" of the allen driver should be inserted into the socket of the bolt). Repeat steps 7 for the tailgate end.

8. Re-measure to verify that the base rails have remained parallel and flat, then fully tighten cab and tailgate assemblies to a torque specification of 9 ft. lbs.

(Note: To ensure the base rail remain Parallel and In Plane, keep straight edge on tracks until rails have been completely installed. The flatter and straighter they are, the better the slide!)

9. After the base rails are secured in the front and rear, tighten the middle stake pocket assembly. Middle stake pocket assemblies are required on 8' beds only.

10. Tighten all stake pocket assemblies to a torque specification of 9 ft. lbs.

CAUTION: For proper installation, use a torque wrench (not included) to verify the torque spec.

11. Thread and tighten (4) 1/4-20 x 3/8" safety bolts onto the "T"s at the cab end of the base rails.

CAUTION: All safety bolts must be installed, and all knobs tightened, prior to operating the vehicle on the road.

Now you're ready for the overhead rack assembly.

For good performance and safety, periodically check that the base rails remain parallel and secure. Re-torque all fasteners to the proper specification after the first 500 miles, and every 10,000 miles thereafter.

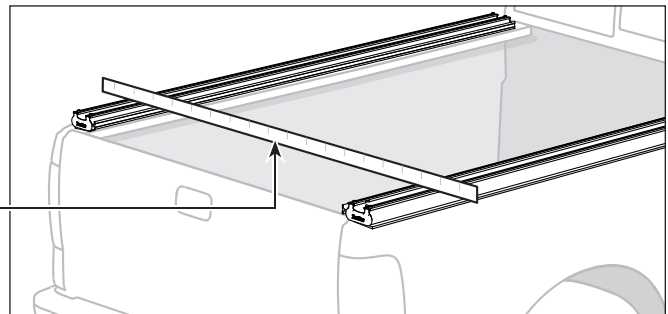

Please review the enclosed CAUTION sheet for additional guidelines.

BASE RAIL INSTALLATION:

For trucks without stake pockets

You'll be attaching the base rails to the side rails of the truck the old-fashioned way – by drilling 4 – 6 holes and bolting the rails in position.

C-clamp base rails onto the truck - making sure the rails are in correct position for drilling. Rails must remain parallel within 1/16". Use the holes specified for your truck and mark each center.

Drill 13/32" diameter holes at each marked point and fasten in place with the 3/8-16 x 3" socket head cap screws, the plastic washers, the 1/8" thick rubber spacers, and brass pocket nuts.

BASE RAIL INSTALLATION:

Trucks with bedliners "Over the Rail"

Make sure that the bedliner is straight and in proper position before drilling any holes!

TracRac works with over the rail bedliners – and even helps prevent the bedliner from slipping or shifting. Unless your bedliner comes with removable pocket tabs, you'll be drilling holes through the bedliner to secure the base rails into the stake pockets. The base rails themselves will rest on top of the bedliner.

1. Verify that you have received the correct parts, and that the base rails correspond to your pickup truck make, model, and year.
2. Locate the correct hole pattern in the base rails for your truck by referring to the enclosed base rail layout drawing. Note: Labels at the end of each base rail identify the front and side of the truck the rails must be placed on.
3. Use the plastic access plugs to cover the holes that do not correspond to your truck.
4. Place the base rails on the side rails of your truck in accordance with the layout drawing. If the bedliner flange is flat and in plane, you can mount the base rails directly onto the truck without using the plastic shim.

Otherwise, position the shim on the top of the bedliner to ensure that the base rails remain flat and parallel (the thick side of the shim should face outwards) and/or use the supplied rubber tape as a shim to correct the angle of the base rails.

5. Starting with the front two stake pockets (closest to the cab on the left and right), locate the center of each stake pocket and drill a 3/8" hole through the bedliner. Temporarily place the 3/8-16 x 3" socket head cap screws into the correct front hole on the base rails and into bedliner holes just drilled. Adjust the rear end of the base rails until the rails are parallel. Measure the width from rail to rail using the T-Tracks of each base rail at the same location front and rear. Measurements are to be equal within 1/16". C-clamp the baserails in place. Now using the baserail's rear hole as a template, drill a 3/8" diameter hole in the center of each rear stake pocket.
 6. Unbolt the bedliner, and lift it up to gain access to the stake pockets. We suggest you place a small wooden block (2" x 4" x 4") in between the bedliner flange and the side rail of the truck. This will permit you to access the stake pocket.
 7. Slide one plastic washer onto each 3/8-16 x 3" socket head cap screw. Insert the cap screws into the holes of the base rail, through the plastic shim (again, only use shim if needed), through the bedliner, through the rubber expansion block and into brass nut.
- Tip: Tape or glue the brass pocket nuts to the rubber expansion blocks before inserting them into the stake pockets of the truck. This will stop the nuts from dropping into the stake pockets if you ever need to loosen and remove the rails.*
8. Hand tighten the brass pocket nuts just enough to hold the rubber expansion blocks in place against the plastic shim or bedliner (without compressing the rubber block). Remove the wooden blocks, and insert the entire assembly into the stake pockets.
 9. Continue with steps 6 through 10 of the Base Rail Installation Instructions (*page 6*): Trucks without Bedliners.

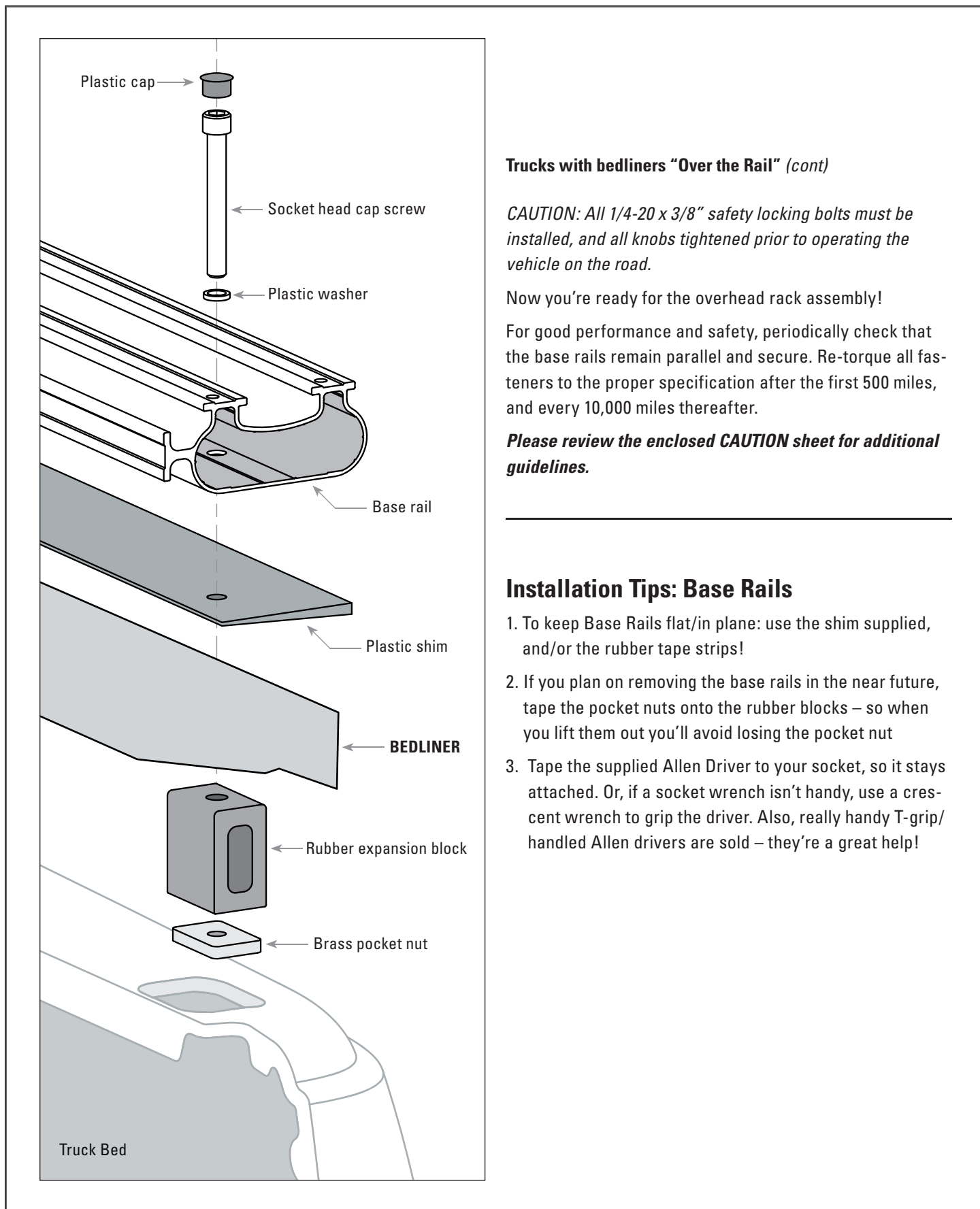

Trucks with bedliners "Over the Rail" (cont)

CAUTION: All 1/4-20 x 3/8" safety locking bolts must be installed, and all knobs tightened prior to operating the vehicle on the road.

Now you're ready for the overhead rack assembly!

For good performance and safety, periodically check that the base rails remain parallel and secure. Re-torque all fasteners to the proper specification after the first 500 miles, and every 10,000 miles thereafter.

Please review the enclosed CAUTION sheet for additional guidelines.

Installation Tips: Base Rails

1. To keep Base Rails flat/in plane: use the shim supplied, and/or the rubber tape strips!
2. If you plan on removing the base rails in the near future, tape the pocket nuts onto the rubber blocks – so when you lift them out you'll avoid losing the pocket nut
3. Tape the supplied Allen Driver to your socket, so it stays attached. Or, if a socket wrench isn't handy, use a crescent wrench to grip the driver. Also, really handy T-grip/handled Allen drivers are sold – they're a great help!



TIPS FOR CARE AND MAINTENANCE

If You Plan To Remove Your Rails

1. Place a thin strip of rubber tape or rubber membrane (roofer's tape) on the underside of the plastic shim before you position the base rails on the truck. A fresh coat of wax is also recommended. This will reduce friction/chafing over time.
2. Tape or glue the brass pocket nuts to the rubber expansion blocks before inserting them into the stake pockets of the truck. This will insure that you don't drop the nuts into the stake pockets if you loosen them to remove the rails.

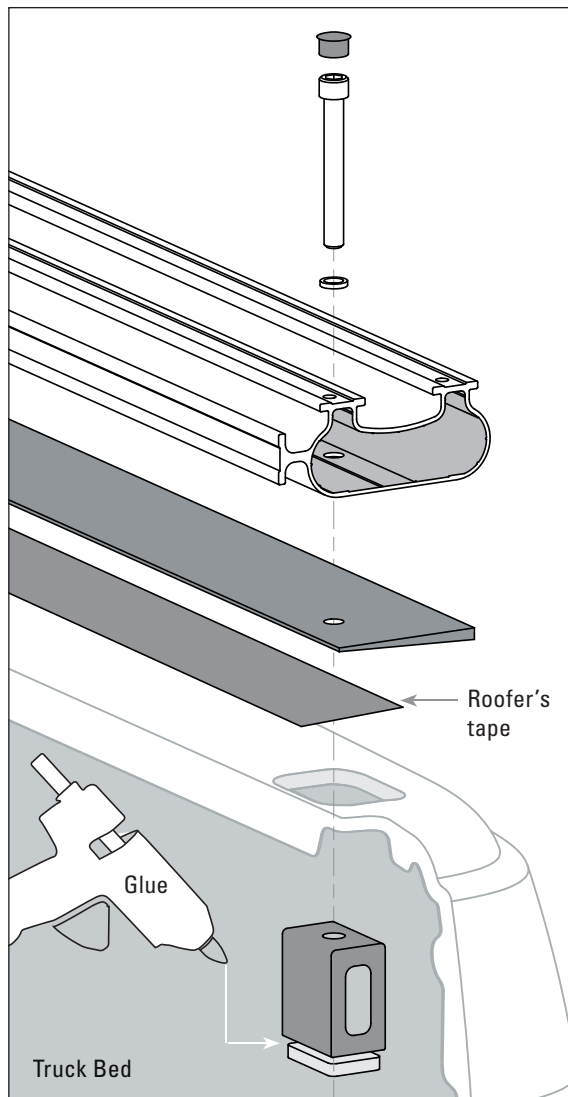

General Care

Periodically retighten all fasteners and check the torque on the rubber expansion blocks (we recommend checking every 4 months). Over time, with repeated use, the TracRac may loosen slightly.

2. Salt, soap scum, and other debris may inhibit the slide of the racks and accessories, over time.

We find that spraying the rails occasionally with *Armor-All* or *Son-Of-A-Gun* will enhance sliding.

3. If racks or accessories don't slide easily even after spraying/wiping down; there are two other likely solutions:

- a) Your rails are not parallel; re-measure, loosen, adjust and retighten carefully.
- b) Your overhead racks are unevenly tightened/out of position. To adjust, slide the base of the overhead rack up against the safety locking bolts at the rear of the base rails, left and right. Tighten the knobs, loosen fasteners, pull each rack corner to the outside (away from the bed), measure to confirm that the crossbar is centered, and tighten down again carefully.

4. The knobs on your TracRac are made from stainless steel. To prevent them from seizing up, we find that applying some *Never-Seize* type lubricant works wonders (common household *Vaseline* can suffice).

5. When mounting lights or other electrical systems to your TracRac, do not use any component of the system as a ground or to carry an electrical current. Always run 2 wires to the electrical unit - one positive lead to the switch for power and one ground lead to the frame of the vehicle. Make sure the power lead has an appropriate size fuse.