

Power ZG
w/air massage

Owners' Manual

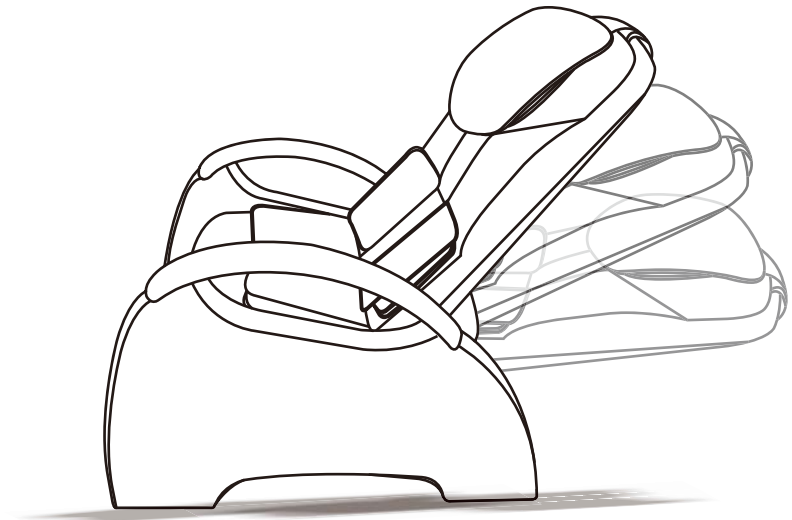

[www. ib-wellness.com](http://www.ib-wellness.com)
INNER BALANCE WELLNESS
A Division of Johnson Health Tech, NA.
2690 Research Park Drive - Suite A - Fitchburg, WI 53711

ZG-571

Please read this Owners' Manual thoroughly prior to using this product.

Thank you for purchasing the Inner Balance “Power ZG w/air Massage Chair”. Before using this product please read these instructions completely to ensure proper usage of this product.

Safety Instructions	02
Grounding Instructions	04
Important Safety Instructions	05
Proper Use of the Chair	06
Daily Maintenance of the Chair	07
Troubleshooting Guide	08
Components and Accessories	09
Setup Instructions	10
Moving the Chair Around	13
Function Keys	14
Function Descriptions	15
Features and Functions	20
Maintenance and Storage	21
Product Specifications	22
Standard Warranty Terms	23
Requesting Warranty Services	24



To prevent any injuries or accidents, children should not be allowed to use the chair.



Unplug the power cord and keep your hands dry before doing any maintenance.



Users must stop and turn the power off immediately, if they feel ill when using the chair.

Users with any of the following conditions must consult their physician prior to using the chair:



- a. People with heart diseases.
- b. People with malignant tumors.
- c. Women who are pregnant or menstruating.
- d. People with spinal abnormalities or curvature.
- e. People who are currently being treated for an ailment by a doctor or have just completed treatment.
- f. People with osteoporosis.

Warning

If the chair is functioning abnormally turn off the main power switch and unplug the unit. Contact the manufacturer immediately for assistance. Do not attempt to disassemble or repair the chair yourself.



Do not place the chair where it is directly exposed to sunlight and don't place the product near electric appliances.



Do not clean the chair with harsh cleaners containing alcohol or other solvents.



DO NOT

Do not use the chair in an environment that is dirty, greasy, smoggy, or excessively humid.

Immediately stop using the chair and **UNPLUG** the power cord if the upholstery is torn or worn-out exposing any of the mechanisms. Contact the manufacturer immediately for assistance.

This chair is intended for use by one person at a time, **DO NOT** use the chair for multiple people at a time.

People under the age of 16 should not use the chair unless under the close supervision of an adult guardian. Do not eat or drink while using the massage chair.

It is recommended to turn off the chair after 4 hours of use, also between massages a short break of several minutes is recommended.

This product must be grounded. If it should malfunction or breakdown, grounding provides a path of least resistance for electric current to reduce the risk of electric shock. This product is equipped with a cord having an equipment-grounding conductor and a grounding plug. The plug must be plugged into an appropriate outlet that is properly installed and grounded in accordance with all local codes and ordinances.

DANGER Improper connection of the equipment-grounding conductor can result in a risk of electric shock. Check with a qualified electrician if you are in doubt as to whether the product is properly grounded. Do not modify the plug provided with the product—if it will not connect to outlet, have a proper outlet installed by a qualified electrician.

This product is for use on a nominal 120-volt circuit and has a grounding plug that looks like the plug illustrated in sketch A in the figure below. Make sure that the product is connected to an outlet having the same configuration as the plug. No adapter should be used with this product.

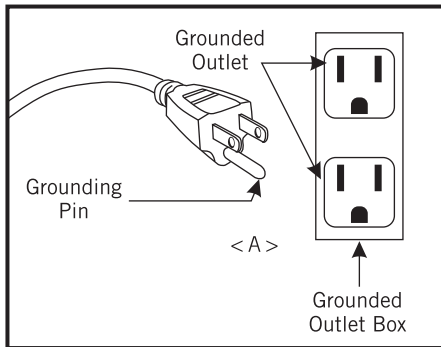

When using an electrical massage chair, basic precautions should always be followed, including the following:

Read all instructions before using the massage chair.

DANGER To reduce the risk of electric shock:

- 1) Always unplug this massage chair from the electrical outlet immediately after using and before cleaning.

WARNING To reduce the risk of burns, fire, electric shock, or injury to persons:

- 1) A massage chair should never be left unattended when plugged in. Unplug from outlet when not in use, and before putting on or taking off parts.
- 2) Do not operate under blanket or pillow. Excessive heating can occur and cause fire, electric shock, or injury to persons.
- 3) Close supervision is necessary when this massage chair is used by children, or disabled persons. Keep children away from the extended foot support and reclining backrest.
- 4) Use this massage chair only for its intended use as described in this manual. Do not use attachments not recommended by the manufacturer.
- 5) Never operate this massage chair if it has a damaged cord or plug, if it is not working properly, if it has been dropped or damaged, or dropped into water. Please contact the manufacturer directly for support if there are any issues with the chair.
- 6) Do not carry this appliance by supply cord or use cord as a handle .
- 7) Keep the cord away from heated surfaces .
- 8) Never operate the massage chair with the air openings blocked. Keep the air openings free of lint, hair, and the like.
- 9) Never drop or insert anything into any opening.
- 10) Do not use outdoors.
- 11) Do not operate where aerosol (spray) products are being used or where oxygen is being administered.
- 12) To disconnect, turn all controls to the off position, then remove the plug from the outlet.

WARNING Connect this massage chair to a properly grounded outlet only. See grounding instructions.

SAVE THESE INSTRUCTIONS



Warning

In order to protect the chair and extend its lifespan, please pay careful attention to and follow the instruction for use of the chair.

- 1A The motors, electronic components, and mechanisms in this massage chair are designed for 60-minute-non-stop use. Exceeding this length of time will result in automatic stoppage.
- 2A It is recommended that users do not exceed 30 minutes of massage at a time. Exceeding the recommended time may result in users feeling unwell or uncomfortable.
- 3A Between massages it is important to let both the user and chair rest for several minutes.
- 4A Do not leave the chair unattended while it is operating. Switch it off while not in use.
- 5A Please be patient with the program reaction time of the controller. Most of the buttons take about 2 to 3 seconds to react for your input, but some of the buttons may take about 5 seconds to react for input, especially for the changes of the default programs.
- 6A Do not sit or stand on the leg rest when it is in the up or reclined position.
- 7A If the chair is placed in a cold environment (Under 5°C/41°F) for an extended period of time, it is suggested to increase the surrounding temperature to a normal room temperature (15°C~20°C/59°F~68°F), and wait for about 1 hour before use.
- 8A It is suggested to drink approx. 250cc of water after using the chair, this could also help with better blood circulation.

Damage caused by the user attempting to disassemble the chair themselves or modify the chair will void the warranty.

1. Long Term Storage

It is recommended to place the chair in a low humidity environment and cover it with cloth to prevent dust and scratches to the upholstery. Do not place the chair where it is directly exposed to sunlight and don't place the product near electric appliances.

2. Maintenance

Switch the power off and unplug the product before beginning cleaning. Only use non-abrasive cleaners on the product, and make sure product is polished dry with a cloth. Do not use heated devices like an iron or hair dryer on the chair. Do not clean the upholstery with a washer or dryer. Not following these recommendations will result in damage to the product.

3. Remote Control

Use only a dry cloth to wipe the remote control. To avoid damage to the controller do not pull, stretch; or place heavy objects on the controller or its cord. Please use the remote control with care. Please avoid dropping the controller in order to prevent it being damaged.

Whenever the chair is performing abnormally, or won't operate, please unplug the power cord and contact the manufacturer directly for service.

STATUS	POSSIBLE REASON
<ul style="list-style-type: none">● The chair wont operate	<ul style="list-style-type: none">● Confirm that it is plugged firmly into the wall socket● Is the power on?

- Do not use the chair if the Back Pad or Seat Pad is damaged.

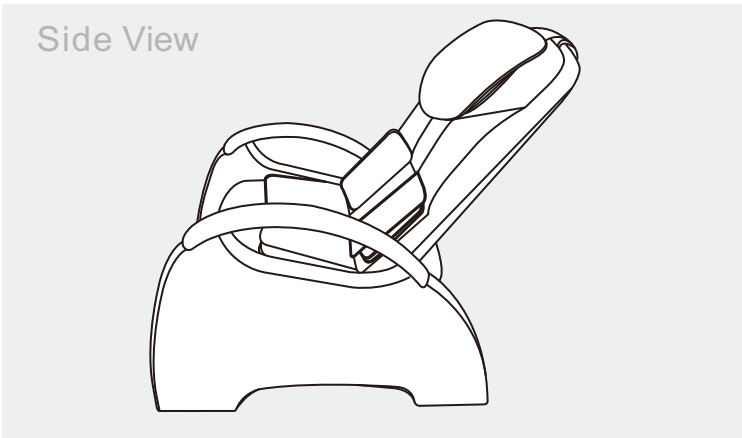
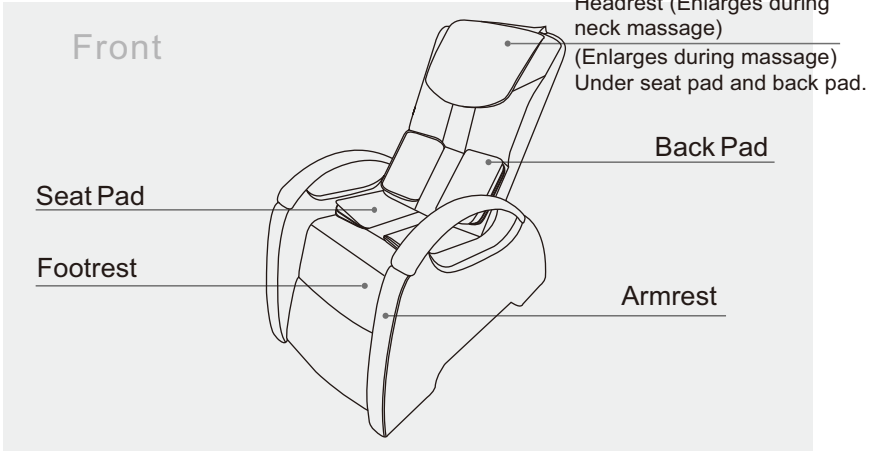

Accessories

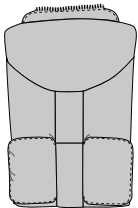

Back Pad

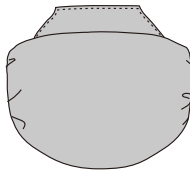

Headrest



Power Cord



Manual



STEP 1: Removing the Massage Chair

- Remove the chair from box.
- More than one person is needed to lift and remove the chair, below areas are shown to use as hand holds.

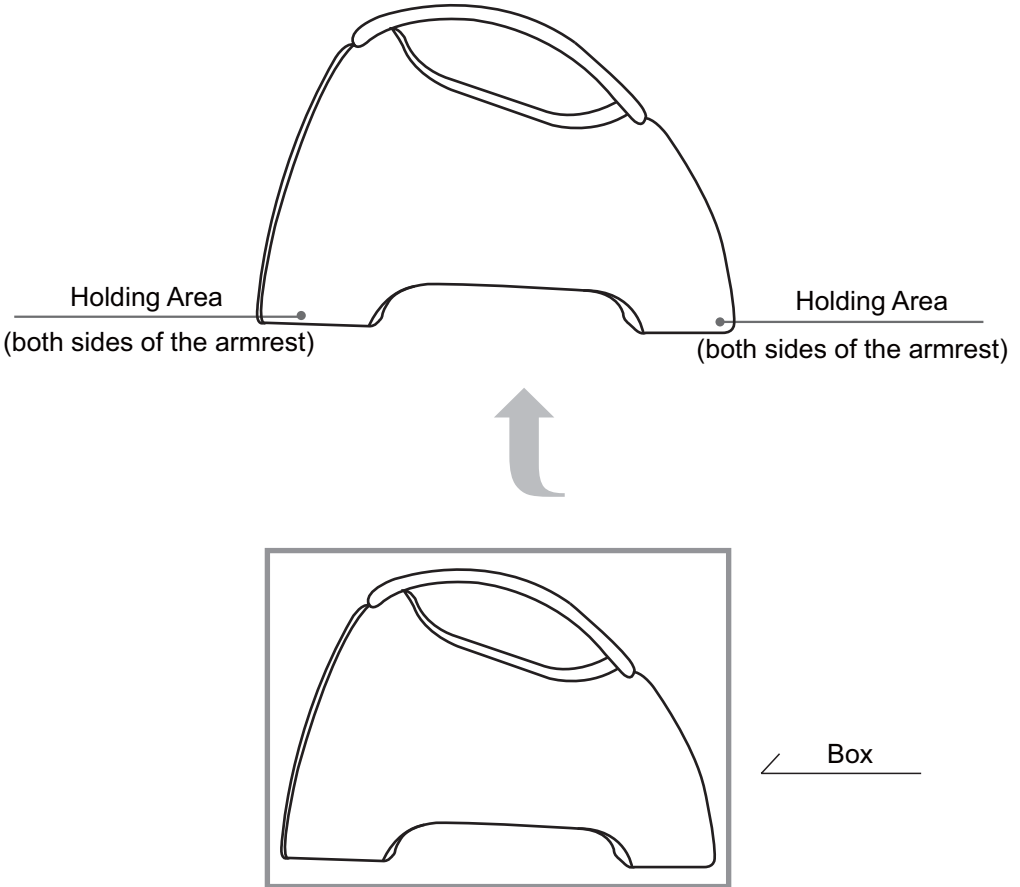

STEP 2: Setting up the Massage Chair

- When the massage chair is removed from the box, place the backrest in an upright position.
- Move the backrest to an upright position (to approx. 120 degrees) until a “CLICK” sound is heard. This will indicate that the backrest is locked into place.

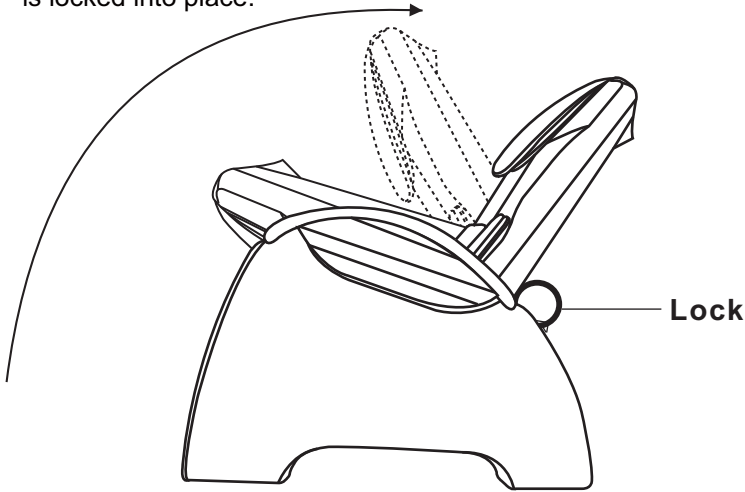

STEP 3: Setting up the Back Pad

Place the back pad at the position where the zipper is on the backrest.

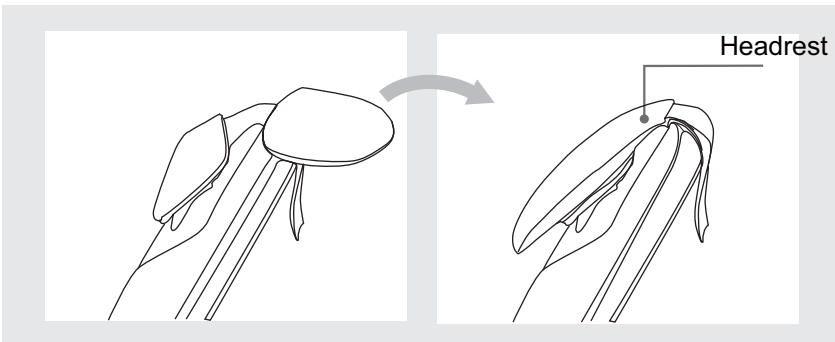



STEP 4: Setup completed

When the above assembling is completed as recommended, attach the power as in the picture and turn on the power. The chair is now ready to be used, and to serve you with a relaxing and comfortable massage.

If the chair is plugged in and can't be operated, check the switch.

Note: Please check for obstacles when adjusting the Backrest / Footrest Up/ Down.

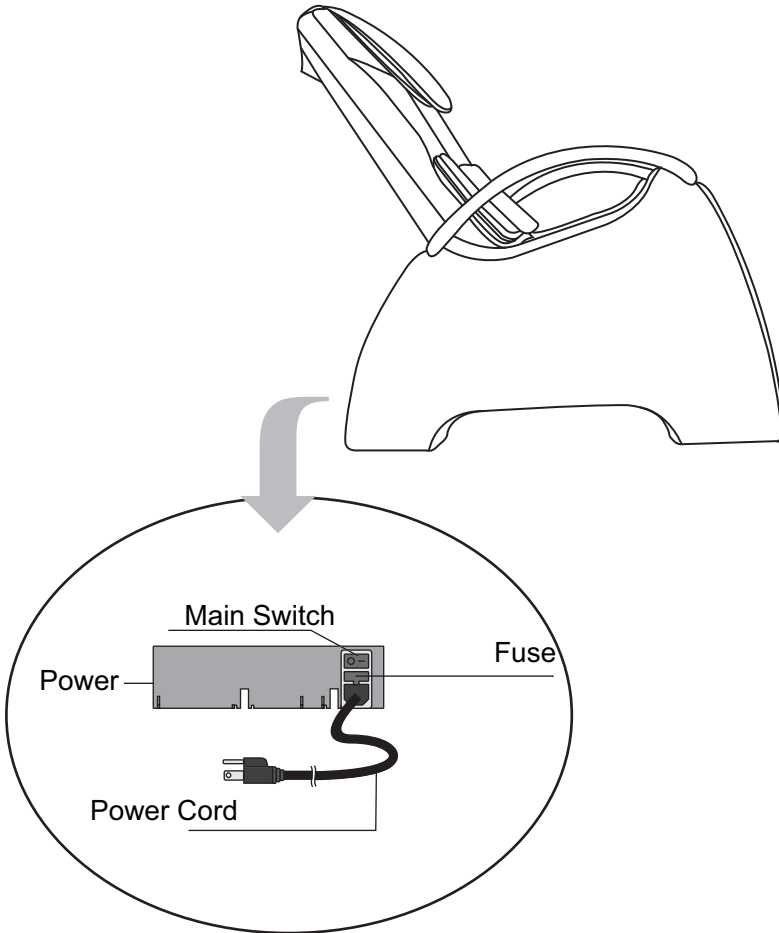



Moving Way 1

Unplug the power cord and lift the chair a little using proper lifting technique, then push the chair forward.

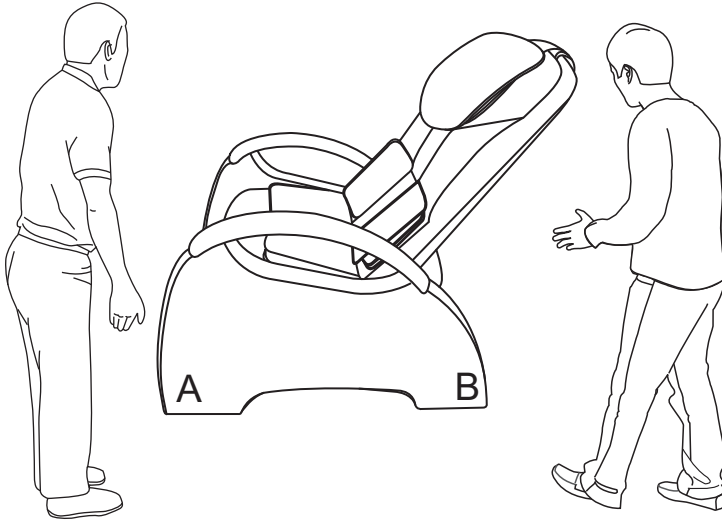

Moving Way 2

Please unplug the power cord before moving.

Using proper lifting technique handle the chair using the hand holds and lift in accordance with step 1's set-up instructions, you will need multiple parties for this.

Note: Do not move the chair when it is in use.

Please read the instruction manual carefully, in order to operate the chair proficiently. Refer to the information below for the function keys.

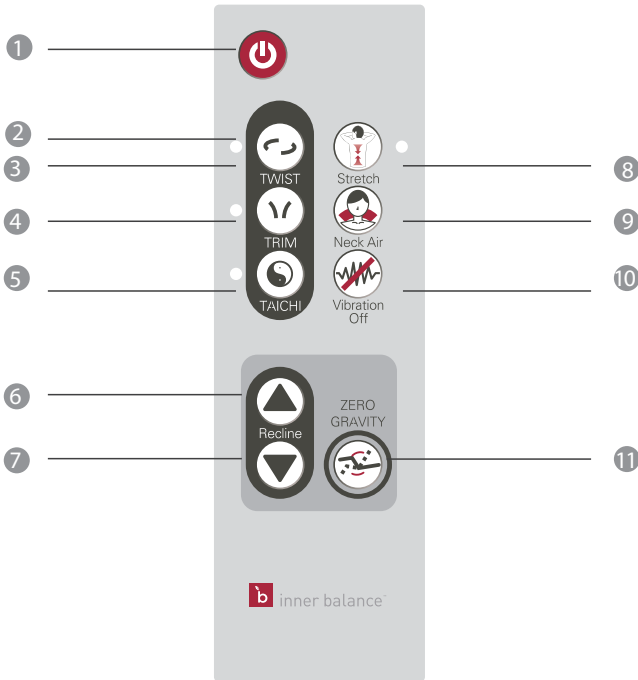

NOTE:

- Do not use foreign or hard objects to press the controller's buttons, including fingernails. Improper use will result in damaging the controller.
- Do not drop the controller. Keeps hands dry while using the controller.
- Do not sit or step on the controller.
- Do not press the buttons too hard.
- Turn off the power after you are finished using the chair and put it into the pocket after usage.

- ① Power (Start/Stop)
- ② LED Display
- ③ Massage Program I
TWIST Massage
- ④ Massage Program II
TRIM Massage
- ⑤ Massage Program III
TAICHI(Soft) Massage
- ⑥ Backrest Adjustment
Concurrent adjustment
on backrest (Up) and
footrest angle (Down)
- ⑦ Backrest Adjustment Concurrent
adjustment on backrest (Down)
and footrest angle (Up)
- ⑧ Air Massage
Back &Waist Stretch Massage
- ⑨ Air Massage
Neck Massage
- ⑩ Vibration (Stop)
- ⑪ Zero Gravity Angle Recliner
Zero gravity angle/Return to
home position.



- To prevent injury or damage to the chair, please ensure that there are no obstructions in front of or behind the unit when adjusting reclining angles.
- Do not sit on, drop or exert extreme pressure on the control panel.
- Please ensure hands are dry during operation of the unit and controller.
- The controller may be affected by your watch, ring, or other metallic equipment; please remove during use.

Power(Start/Stop)

Press this button to turn the chair on/off.

When the power switch is on the chair is in standby mode.

If the LED is inoperative the power switch is not on.

Press the power button to turn on the chair, use alternate buttons to control the chair, press the power button again to return to an upright idle position.

StandBy

When the power button has been pressed the LED light will begin cycling and the chair is ready for use.

Recline Motor Overloading

If the recline motor has overloaded all LED's will light up at the same time.

Auto Program

The chair features 3 default programs.

Choose your preferred program under I/II/III to perform the default techniques.

All are preset with reclining angles but you can always adjust your preferred angle.

Massage Program I: TWIST Massage

Press the button to turn on/off the function.

Principal massage are a moderate twist massage to relax tired muscle.

The preset time is 15 minutes.

Massage Program II: TRIM Massage

Press this button to turn this function on/off.

The principle of this massage is to promote a soft rhythmic technique to refresh the user. The preset time is 15 minutes, and the LED shows the functioning massage.



- The preset time is about 15 minutes.
- Press the button to turn on the function, double-click to turn off the function, but the chair will not return to home position.

Massage Program III: Taichi (soft) Massage

Press this button to turn this function on/off.

The beginning of this massage starts slow and soft, then will increase in speed and strength. This program will automatically increase the massage as it goes along for overall relaxation of fatigued body muscles. The preset time is 15 minutes, and the LED shows the functioning massage.

Backrest Adjustment

Press the button to adjust the angle of the backrest, press and hold the up or down button to adjust the angle of the backrest. Continuously holding the up or down button can synchronize the movement of the backrest and footrest.



- If you press the recline button 20 times in a row all the LED's will light up and the chair will cease any activity. Please turn off the main power, after turning the main power back on the chair can be used again.
- This is designed for protecting against child use.

Air Massage

Press the Stretch/Neck Air button to turn on the air massage function, the chair will automatically perform inflation and deflation of air bag.

Massage program: Stretch Massage

Press this button to turn this function on/off.

The purpose of this massage is to focus on the lower back and waist to stretch the waist and release body fatigue. The preset time is 15 minutes. The program will automatically adjust the strength and speed of the air bag for the user.



- The preset time is about 15 minutes.
- Focus:Waist stretch, stretch like action.

Massage Program : Neck Massage

Press this button to turn this function on/off.

The purpose of this massage is to use mild techniques to relax neck fatigue and tired muscles. The preset time is 15 minutes.The program will automatically adjust the strength and speed of the air bag for the user.



- The preset time is about 15 minutes.
- Focus: Relax tired and fatigued muscles caused by working and reading.

Vibrate (Stop)

Massage Program: Vibration Massage

Press this button to turn this function on/off.

This program focuses on the overall body massage. The massage incorporates mild techniques to dispel the fatigue of the shoulders, neck, and back.



- This function is able to work with auto programs and can't be operated separately.
- Press the button to stop auto program and double clicking it will restart the auto program.
- This function is mainly for relaxing total body muscle tension and the release of tired muscles.

Zero Gravity Recline

Press this button to recline into the Zero Gravity position and return to the upright position.

This is a therapeutic position for your body to be in having your legs above the heart helps reduce pressure on the spine.

When you execute zero gravity reclining the back, buttocks, and legs can be synchronized to reach the full recline position. The pressure will be relieved and fatigue will be dispelled by reclining in different positions.

This function is able to work with the 3 auto massage programs and air massage.

- 3 Pre-programmed massage courses to gently twist and stretch muscles surrounding the back waist and neck.
- 3 Manual massage functions including Stretch, Neck Massage and Vibration.
- Power recline to full Zero Gravity position to decompress spine, stimulate blood circulation and relax muscles in the back.
- Fully adjustable, power recline and rise function with one touch “Zero G” positioning.
- 15 minute auto shut-off timer.

- If the chair is placed in a cold environment (Under 5°C/41°F) for an extended period of time, it is suggested to increase the surrounding temperature to a normal room temperature(59°F~68°F), and wait for about 1 hour before use.
- Please switch off the chair and unplug its power cord from the wall outlet when cleaning the chair.
- Never use thinner, benzene or alcohol to clean the unit.
- Use a dry cloth thoroughly wrung out, and do not wipe the product with a wet cloth.
- Do not place the unit near exposed heaters, heat sources, or direct sunlight.
- If you do not use the unit for a period of time it is suggested to unplug the unit and store it in a clean and dry environment.
- Do not eat or drink on the unit.

Product Name : Power ZG w/air massage

Model Number : ZG-571

Voltage : AC110-120V~, 50-60Hz
AC220-240V~, 50-60Hz

Max. Consumption : 120W

Timer range : 15 minutes

Lying Angle : Approx. 123-170 degrees

Measurement : Approx. 119 x 75 x 112cm

Weight : Approx. 62 KG

Code Number :

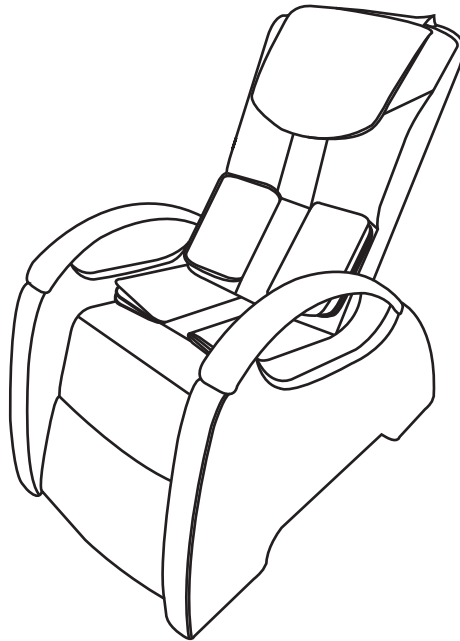

STANDARD WARRANTY TERMS

Inner Balance Wellness products are backed by limited warranties against defects in materials and workmanship. For information related to your product, contact Customer Service at (877) 217-2862 or email us at service@ib-wellness.com.

- Warranty coverage begins on the date the consumer purchases the product.
- This warranty only applies to the original end user/owner of the chair and is non-transferable.
- This product is intended for home use only. Any use in a commercial setting will void the warranty of this product.
- Warranties are only valid within the United States & Canada, provided the product has been operated according to the enclosed instructions.

Product	In-Home Service	Parts	Frame
Massage Chairs	1 Year	2 Years	5 Years
Zero Gravity Chairs	1 Year	2 Years	3 Years
Accessories	1 year hassle free replacement warranty*		

* To be eligible for the hassle free replacement warranty the product must be in possession of original owner and have receipt or other valid proof of purchase.

NOT COVERED BY WARRANTY

Any loss or damage resulting from: improper installation, unauthorized repairs, alterations or modifications of original condition, improper use of electrical power supply, loss of power, power surges, failure to follow operating instructions, transportation damage, abuse, misuse or environmental conditions, loss of use during repairs, and products purchased from unauthorized dealers.

All returns for issues other than the aforementioned are subject to a 20% restocking fee. Goods are required to be packaged in original un-opened packaging and the user is responsible for the cost of the freight shipping the parcel back to us.

Damage incurred due to shipping and handling does not constitute a defect under this warranty.



REQUESTING WARRANTY SERVICES

All warranty service requires approval and au-thorization by Inner Balance Wellness. Con-sumers can contact the Inner Balance Wellness Customer Service department between the hours of 9:00 AM and 5:00 PM CST, Monday through Friday, at (877) 217-2862 or via email at service@ib-wellness.com.

Products require a Return Authorization num-ber (RA) for any returns. Products received with-out a valid RA number will be refused. Inner Balance Wellness will not issue RA numbers for “Buyer’s Remorse” or freight damage for ship-ments to consumer, except for drop shipments direct from Inner Balance Wellness.

During the In-Home service and Parts warranty period, Inner Balance Wellness, at its sole dis-cretion, will repair or replace any defective part within a reasonable length of time. If a particu-lar part is not available, reasonable efforts will be madeto locate a compatible replacement part. If a compatible part is not available, Inner Balance Wellness may replace your product with the same or a similar product of equal value.

For In-Home Service, Inner Balance Wellness will arrange for all covered parts deemed necessary for repairs to be sent to the consumer. Once the parts are received by the consumer, they will be contacted by an authorized service provider to schedule repair of the product at the customer’s residence at no charge to the consumer. In-home service is available within 150 miles of the nearest authorized Service Provider (mileage beyond 150 miles from an authorized service center is the responsibility of the consumer).

Any repairs needed during the Parts warranty coverage, Inner Balance Wellness will provide parts at no cost and contact information for a service provider in their area. The labor fees af ter the first year of ownership are the responsi-bility of the consumer as the labor warranty will have expired.