



Allen-Bradley

Technical Data



PowerFlex[®] 700 Adjustable Frequency AC Drives



PowerFlex® 700 Adjustable Frequency AC Drives Technical Data

The PowerFlex 700 AC drive offers outstanding performance in an easy-to-use drive that you have come to expect from Rockwell Automation. This world-class performance comes in a small and competitively priced package. The PowerFlex 700 AC drive is designed to control three-phase induction motors in applications with requirements ranging from the simplest speed control to the most demanding torque control. Two configurations are available: Standard Control which includes volts per hertz and sensorless vector control; and Vector Control which includes volts per hertz, sensorless vector and vector control. The Vector Control option includes Allen-Bradley's patented Force Technology™ which provides world class motor control.



Table of Contents

Description	Page
Standard Drives Program	3
Catalog Number Explanation	5
PowerFlex 700 Drives	6
Option Selection	7
Accessories	11
PowerFlex 700 Standard Packaged Drives	14
Power Wiring	17
Power Terminals	18
Control Terminals	21
Cable Recommendations	25
Power Ratings, Circuit Branch Protection and Power Dissip.	26
Maximum Lead Lengths	31
Approximate Dimensions	33
Control and Performance	39
Voltage Tolerance	41
Parameter List	42

Standard Drives Program

Flexible Packaging and Mounting

- **IP20, Type 1** — For conventional mounting inside or outside a control cabinet. Conduit plate is removable for easy installation and replacement without disturbing conduit.
- **Zero Stacking™** — Drives can be mounted next to each other with no reduction of surrounding air temperature rating (50°C). This unique bookshelf design also allows access to one drive without disturbing another.



Space Saving Hardware Features

- **Integral EMC Filtering** plus built-in common mode cores and common mode capacitors provides a compact, all-in-one package solution for meeting EMC requirements, including CE in Europe.
- **Internal Communications** allow the user to integrate the drive into the manufacturing process. Status indicators for all internal communication options are visible on the cover for easy setup and monitoring of drive communications. Users can easily manage information from shop floor to top floor and seamlessly integrate their complete system as they control, configure and collect data.
- **Integral Dynamic Brake Transistor** delivers a cost effective means of switching regenerative energy without costly external chopper circuits.
- **Internal Dynamic Brake Resistor** (up to 25 HP) requires no extra panel space, and supplies a large amount of braking torque for short periods.

Easy to Use Human Interface Tools

The PowerFlex 7-Class AC drives provide common Human Interface tools that are familiar and easy to use. These include the LCD Human Interface modules and PC-based configuration tools.

LCD Human Interface modules provide:

- Large and easy to read 7 line x 21 character backlit display
- Variety of languages (English, French, German, Italian, Spanish, Portuguese, Dutch)
- Alternate function keys for shortcuts to common tasks
- “Calculator-like” number pad for fast and easy data entry (Full Numeric version only)
- Control keys for local start, stop, speed, and direction
- Remote versions for panel mount application

PC-based Configuration tools include:

- DriveExplorer™ and DriveExplorer Lite
 - A simple and flexible “On-line” tool for monitoring and configuration while connected to a drive.
- DriveTools™ SP
 - A suite of software tools which provide an intuitive means for programming, troubleshooting and maintaining Allen-Bradley AC & DC drives.

Standard Drives Program, Cont'd

Outstanding Control and Performance

Allen-Bradley drive's Vector Control utilizes patented Force Technology which provides excellent low-speed performance - whether it is operated with or without feedback. While this industry-leading control provides the highest level of drive performance, it is as easy to use as any general purpose drive available. **Multiple motor control** algorithms allow performance matched to the application need:

- **Volts/Hertz** for simple Fan and Pump applications
- **Sensorless Vector** for high torque production over a wide speed range
- **Vector** for outstanding torque regulation and excellent low speed / zero speed performance (with Vector control cassette).

Drives Features

- Fast-acting **Current Limit** and **Bus Voltage Regulation** result in maximum acceleration and deceleration without tripping.
- **High speed analog inputs** improve drive response to torque or speed commands.
- **Programming flexibility** allows parameters to be linked within the drive.
- **Flying Start** delivers smooth connection into rotating loads, regardless of commanded direction, without the need for any speed feedback.
- **Integral Process PI Control** can eliminate the need for a separate process loop controller.
- **Inertia Ride-Through** offers tripless operation during a prolonged power outage by using the rotating energy stored in high inertia, low-friction loads.
- Speed Regulation as required:
 - **Open Loop Frequency** regulation when speed regulation is not required.
 - **Slip Compensation** delivers a minimum .5% speed regulation without feedback hardware.
 - **Droop** allows drives to load share without fighting each other.
 - **Encoder Feedback** provides up to .001% speed regulation for the tightest application requirements.

Unsurpassed Capability in Network Communications

PowerFlex drives are fully compatible with the wide variety of Allen-Bradley DPI™ communication adapters, offering the following benefits:

DeviceNet™	ControlNet™	EtherNet/IP	Remote I/O	RS-485 - DF1	Profibus	Interbus - S	Description
✓	✓	✓					(Unconnected Messaging) permits other network devices (e.g. PanelView™) to communicate directly to a drive without routing the communication through the network scanner.
✓	✓	✓		✓			Adapter Routing - Plug PC into one drive and talk to all other Allen-Bradley drives on same network, without being routed through network scanner.
✓	✓	✓	✓	✓	✓	✓	Access to 100% of all parameters over the network.
✓		✓			✓		AutoBaud capability makes initial connections less problematic.
✓							Change of State significantly reduces network traffic by configuring control messages to be sent only upon customer defined states. Very flexible configuration for each node (Example: "reference must change by more than 5%.")
✓		✓					Peer Control provides master-slave type control between drives, where one or more slave drives (consumers) can run based on the status of a master drive (producer), which can also significantly reduce network traffic.
✓							ADR (Automatic Device Replacement) saves significant time and effort when replacing a drive, by allowing the scanner to be configured to automatically detect a new drive and download the required parameter settings.
✓	✓	✓	✓	✓	✓	✓	Flexible Fault Configuration - Adapters can be programmed to take fault based actions as ramp to stop, coast-to-stop and hold last state, as well as send user configurable logic control and speed reference values. In addition, different actions can be taken based on whether the network experienced a serious problem (broken cable etc.) versus network idle condition (PLC set to "Program").

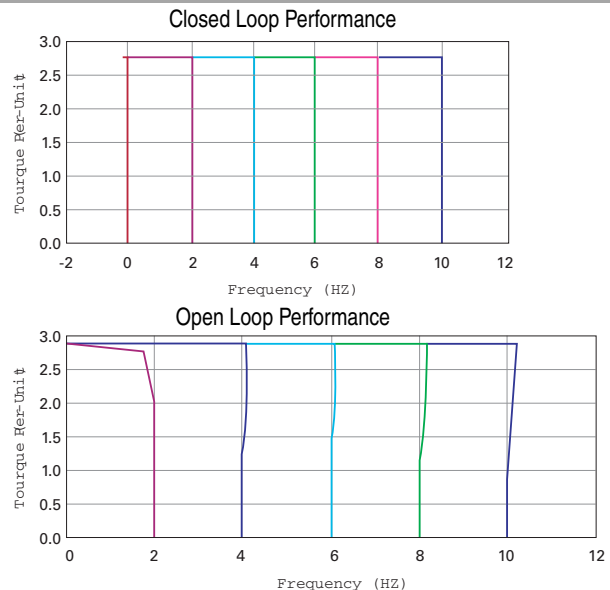

Product Overview

Catalog Number Explanation

Positions 1-8 Base Drive Selection

20B	D	2P1	A	3	A	Y	N	A	R	A	0
Drive	Voltage Rating	Rating	Enclosure	HIM	Documentation	Brake	Brake Resistor	Emission	Comm Slot	I/O	Feedback

Code Type
20B 700

Code Enclosure
A IP 20, NEMA Type 1
N Open

Code	Voltage	Ph.	Prechg.
B	240V AC	3	-
C	400V AC	3	-
D	480V AC	3	-
E	600V AC ⁽³⁾	3	-
F	690V AC	3	-
H	540V DC ⁽⁴⁾	-	N
J	650V DC ⁽⁴⁾	-	N
P	540V DC ⁽⁴⁾	-	Y
R	650V DC ⁽⁴⁾	-	Y

208/240V 60Hz Input				400V 60Hz Input				480V 60Hz Input				600V 60Hz Input ⁽³⁾				690V 60Hz Input			
Code	Amps	Amps	kW (HP)	Code	Amps	kW (HP)		Code	Amps	kW (HP)		Code	Amps	kW (HP)		Code	Amps	kW (HP)	
208	2.5	2.2	0.37 (0.5)	1P3	1.3	0.37 (0.5)		1P1	1.1	0.37 (0.5)		0P9	0.9	0.37 (0.5)		052	52	45 (50)	
2P2	2.5	2.2	0.37 (0.5)	2P1	2.1	0.75 (1.0)		2P1	2.1	0.75 (1.0)		1P7	1.7	0.75 (1.0)		060	60	55 (60)	
4P2	4.8	4.2	0.75 (1.0)	3P5	3.5	1.5 (2.0)		3P4	3.4	1.5 (2.0)		2P7	2.7	1.5 (2.0)		082	82	75 (75)	
6P8	7.8	6.8	1.5 (2.0)	5P0	5.0	2.2 (3.0)		5P0	5.0	2.2 (3.0)		3P9	3.9	2.2 (3.0)		098	98	90 (100)	
9P6	11	9.6	2.2 (3.0)	8P7	8.7	4.0 (5.0)		8P0	8.0	4.0 (5.0)		6P1	6.1	4.0 (5.0)		119	119	110 (125)	
015	17.5	15.3	4.0 (5.0)	015	15.4	7.5 (10)		014	14	7.5 (10)		9P0	9.0	5.5 (7.5)		142	142	132 (150)	
022	25.3	22	5.5 (7.5)	022	22	11 (15)		022	22	11 (15)		011	11	7.5 (10)					
028	32.2	28	7.5 (10)	030	30	15 (20)		027	27	15 (20)		017	17	11 (15)					
042	48.3	42	11 (15)	037	37	18.5 (25)		034	34	18.5 (25)		022	22	15 (20)					
052	56	52	15 (20)	043	43	22 (30)		040	40	22 (30)		027	27	18.5 (25)					
070	78.2	70	18.5 (25)	056	56	30 (40)		052	52	30 (40)		032	32	22 (30)					
080	92	80	22 (30)	072	72	37 (50)		065	65	37 (50)		041	41	30 (40)					
104	120	104	30 (40)	085	85	45 (60)		077	77	45 (60)		052	52	37 (50)					
130	130	130	37 (50)	105	105	55 (75)		096	96	55 (75)		077	77	55 (75)					
154	177	154	45 (60)	125	125	55 (75)		125	125	75 (100)		099	99	75 (100)					
192	221	192	55 (75)	140	140	75 (100)		140	140	75 (100)		125	125	90 (125)					
				170	170	90 (125)		156	156	90 (125)		144	144	110 (150)					
				205	205	110 (150)		180	180	110 (150)									

- (1) Not available for Frame 3 drives or larger.
 (2) Brake IGBT is standard on Frames 0-3 and optional on Frames 4-6.
 (3) Note: CE Certification testing has not been performed on 600V class drives.
 (4) Frames 5 & 6 Only.
 (5) Vector Control Option utilizes DPI Only.

208/240V AC, Three-Phase Drives

Output Amps						Nominal Power Ratings				IP20, NEMA Type 1		Frame Size
240V AC Input ①			208V AC Input			Normal Duty		Heavy Duty		Catalog Number		
Cont.	1 Min.	3 Sec.	Cont.	1 Min.	3 Sec.	kW	HP	kW	HP	20B . . .		
2.2	2.4	3.3	2.5	2.8	3.8	0.37	0.5	-	0.33	B2P2A0AYNBNA0		0
4.2	4.8	6.4	4.8	5.6	7.0	0.75	1.0	0.37	0.75	B4P2A0AYNBNA0		0
6.8	9.0	12	7.8	10.4	13.8	1.5	2.0	0.75	1.5	B6P8A0AYNBNA0		1
9.6	10.6	14.4	11	12.1	17	2.2	3.0	1.5	2.0	B9P6A0AYNBNA0		1
15.3	16.8	23	17.5	19.3	26.3	4.0	5.0	2.2	3.0	B015A0AYNBNA0		1
22	24.2	33	25.3	27.8	38	5.5	7.5	4.0	5.0	B022A0AYNBNA0		1
28	33	44	32.2	38	50.6	7.5	10	5.5	7.5	B028A0AYNBNA0		2
42	46.2	63	48.3	53.1	72.5	11	15	7.5	10	B042A0AYNBNA0		3
52	63	80	56	64	86	15	20	11	15	B052A0AYNBNA0		3
70	78	105	78.2	86	117.3	18.5	25	15	20	B070A0ANNANA0		4
80	105	136	92	117.3	156.4	22	30	18.5	25	B080A0ANNANA0		4
104 (80) ②	115 (120)	175 (160)	120 (92)	132 (138)	175 (175)	30	40	22	30	B104A0ANNANA0		5
130 (104) ②	143 (156)	175 (175)	130 (104)	143 (156)	175 (175)	37	50	30	40	B130A0ANNANA0		5
154 (130) ②	169 (195)	231 (260)	177 (150)	195 (225)	266 (300)	45	60	37	50	B154A0ANNANA0		6 ③
192 (154) ②	211 (231)	288 (308)	221 (177)	243 (266)	308 (308)	55	75	45	60	B192A0ANNANA0		6 ③

- ① Catalog number corresponds to output amps in these columns. Drive must be programmed to lower voltage to obtain higher currents shown at right.
 ② Frame 4, 5 and 6 drives have dual current ratings; one for normal duty applications, and one for heavy duty applications (in parenthesis). The drive may be operated at either rating.
 ③ Preliminary data – check for availability before ordering.

PowerFlex® 700 Drives

380-480V AC, Three-Phase Drives

Output Amps						Nominal Power Ratings				IP20, NEMA Type 1	Frame Size
480V AC Input ❶			380-400V AC Input			Normal Duty		Heavy Duty		Catalog Number 20B . . .	
Cont.	1 Min.	3 Sec.	Cont.	1 Min.	3 Sec.	kW	HP	kW	HP		
1.1	1.2	1.6	1.3	1.4	1.9	0.37	0.5	0.25	0.33	D1P1A0AYNANA0	0
2.1	2.4	3.2	2.1	2.4	3.2	0.75	1	0.55	0.75	D2P1A0AYNANA0	0
3.4	4.5	6	3.5	4.5	6	1.5	2	0.75	1.5	D3P4A0AYNANA0	0
5	5.5	7.5	5	5.5	7.5	2.2	3	1.5	2	D5P0A0AYNANA0	0
8	8.8	12	8.7	9.9	13.2	4	5	2.2	3	D8P0A0AYNANA0	0
11	12.1	16.5	11.5	13	17.4	5.5	7.5	4	5	D011A0AYNANA0	0
14	16.5	22	15.4	17.2	23.1	7.5	10	5.5	7.5	D014A0AYNANA0	1
22	24.2	33	22	24.2	33	11	15	7.5	10	D022A0AYNANA0	1
27	33	44	30	33	45	15	20	11	15	D027A0AYNANA0	2
34	40.5	54	37	45	60	18.5	25	15	20	D034A0AYNANA0	2
40	51	68	43	56	74	22	30	18.5	25	D040A0AYNANA0	3
52	60	80	56	64	86	30	40	22	30	D052A0AYNANA0	3
65	78	104	72	84	112	37	50	30	40	D065A0AYNANA0	3
77 (65)❷	85 (98)	116 (130)	85 (72) ❸	94 (108)	128 (144)	45	60	37	50	D077A0ANNANA0	4
96 (77)❷	106 (116)	144 (154)	105 (85)	116 (128)	158 (170)	55	75	45	60	D096A0ANNANA0	5
125 (96)❷	138 (144)	163 (168)	125 (96)	138 (144)	163 (168)	75	100	55	75	D125A0ANNANA0	5
156 (125)❷	172 (188)	233 (250)	170 (140)	187 (210)	255 (280)	90	125	75	100	D156A0ANNANA0	6
180 (156)❷	198 (234)	270 (312)	205 (170) ❹	220 (255)	289 (313)	110	150	90	125	D180A0ANNANA0	6

600-690V AC, Three-Phase Drives

Output Amps						Nominal Power Ratings				IP20, NEMA Type 1	Frame Size
600V AC Input ❶			690V AC Input			Normal Duty		Heavy Duty		Catalog Number 20B . . .	
Cont.	1 Min.	3 Sec.	Cont.	1 Min.	3 Sec.	kW	HP	kW	HP		
1.7	2.0	2.6	N/A	–	–	0.75	1	0.37	0.5	E1P7A0AYNANA0	0❺
2.7	3.6	4.8	N/A	–	–	1.5	2	0.75	1	E2P7A0AYNANA0	0❺
3.9	4.3	5.9	N/A	–	–	2.2	3	1.5	2	E3P9A0AYNANA0	0❺
6.1	6.7	9.2	N/A	–	–	4	5	2.2	3	E6P1A0AYNANA0	0❺
9.0	9.9	13.5	N/A	–	–	5.5	7.5	4	5	E9P0A0AYNANA0	0❺
11	13.5	18	N/A	–	–	7.5	10	5.5	7.5	E011A0AYNANA0	1❺
17	18.7	25.5	N/A	–	–	11	15	7.5	10	E017A0AYNANA0	1❺
22	25.5	34	N/A	–	–	15	20	11	15	E022A0AYNANA0	2
27	33	44	N/A	–	–	18.5	25	15	20	E027A0AYNANA0	2
32	40.5	54	N/A	–	–	22	30	18.5	25	E032A0AYNANA0	3
41	48	64	N/A	–	–	30	40	22	30	E041A0AYNANA0	3
52	61.5	82	N/A	–	–	37	50	30	40	E052A0AYNANA0	3
62	78	104	N/A	–	–	45	60	37	50	E062A0ANNANA0	4
77 (63)❷	85 (94)	116 (126)	82 (60)	90 (90)	120 (123)	75	75	55	60	E077A0ANNANA0	5
99 (77)❷	109 (116)	126 (138)	98 (82)	108 (123)	127 (140)	90	100	75	75	E099A0ANNANA0	5
125 (99)❷	138 (149)	188 (198)	119 (98)	131 (147)	179 (196)	110	125	90	100	E125A0ANNANA0	6❺
144 (125)❷	158 (188)	216 (250)	142 (119)	156 (179)	213 (238)	132	150	110	125	E144A0ANNANA0	6❺

- ❶ Catalog number corresponds to output amps in these columns. Drive must be programmed to lower voltage to obtain higher currents shown at right.
- ❷ Frame 4, 5 and 6 drives have dual current ratings; one for normal duty applications, and one for heavy duty applications (in parenthesis). The drive may be operated at either rating.
- ❸ 380-400V, 85 A rating is limited to 45°C surrounding air.
- ❹ 380-400V, 205 A rating is limited to 40°C surrounding air.
- ❺ Preliminary data – check for availability before ordering.

Option Selection

Position 9 — Human Interface Modules (HIM)

Position 9 of the catalog string specifies the Human Interface Module (HIM). Four LCD styles are available as well as a blank plate. These HIMs can be factory or user installed.

20B	D	2P1	A	0	N	Y or N	N	A or B	N	N	O
Drive	Voltage Rating	Rating	Enclosure	HIM	Documentation	Brake	Brake Resistor	Emission	Comm Slot	I/O	Feedback

Default Value "0" — HIM Not Used (Blank Cover Included)

Choose User Installed Kit — Leave Default Value "0"

User Installed Kit ①

Description	Handheld/Local (Drivemount) Catalog Number
Blank Plate	20-HIM-A0
LCD Display, Digital Speed	20-HIM-A2
LCD Display, Full Numeric Keypad	20-HIM-A3
LCD Display, Analog Speed Potentiometer	20-HIM-A4
LCD Display, Programmer Only	20-HIM-A5

① Separately-Mounted HIMs can be found on page 11, Accessories.

Choose Catalog Code— Factory Installed Option

Factory Installed Options



Catalog Code: 0
No HIM (Blank Cover)



Catalog Code: 2
LCD Digital Speed



Catalog Code: 3
LCD Full Numeric



Catalog Code: 4
LCD Analog Speed



Catalog Code: 5
LCD Programmer Only

Position 10 — Documentation

Position 10 specifies documentation. Documentation set includes "Language" User Manual, multi-language Quick Start and a CD.

20B	D	2P1	A	0	A	Y or N	N	A or B	N	N	O
Drive	Voltage Rating	Rating	Enclosure	HIM	Documentation	Brake	Brake Resistor	Emission	Comm Slot	I/O	Feedback

Default Value "A" — English Manual

Choose Catalog Code — Factory Installed Option

Description	Catalog Code
English Documentation Set	A
No Documentation Set	N

Option Selection, Cont'd

Position 11 — Internal Brake IGBT

Position 11 specifies the Internal Dynamic Brake IGBT. It is standard on Frames 0-3.

20B	D	2P1	A	0	A	Y or N	N	A or B	N	N	O
Drive	Voltage Rating	Rating	Enclosure	HIM	Manuals	Brake	Brake Resistor	Emission	Comm Slot	I/O	Feedback

Frames 0-3

Default Value “Y” — Internal Dynamic Brake IGBT Installed

No User Kit Available — Leave Default Value “Y”

No Catalog Code Option — Standard Installation

Factory Installed Option

Drive Input Voltage	Brake IGBT	Frame	Catalog Code
208-480V AC	Standard	0-3	Y

Frames 4-6

Default Value “N” — Dynamic Braking Not Used

No User Kit Available — Leave Default Value “N”

Choose Catalog Code — Factory Installed Option

Factory Installed Option

Drive Input Voltage	Brake IGBT	Frame	Catalog Code
208-480V AC	Optional	4	Y
208-480V AC	Optional	5	Y
208-480V AC	Optional	6	Y

Position 12 — Dynamic Brake Resistors

Position 12 specifies the Internal Dynamic Brake resistor. It is available on all drives below 100 HP. This option provides limited dynamic without increasing the drive “footprint.”

Important: These resistors have a limited duty cycle. Refer to the PowerFlex Dynamic Braking Selection Guide to determine if an internal resistor will be sufficient for your application. An external resistor may be required.

20B	D	2P1	A	0	A	Y or N	N	A or B	N	N	O
Drive	Voltage Rating	Rating	Enclosure	HIM	Manuals	Brake	Brake Resistor	Emission	Comm Slot	I/O	Feedback

Default Value “N” — No Dynamic Brake Resistor Included

Choose User Installed Kit — Leave Default Value “N”

User Installed Kit

Drive Input Voltage	Brake Resistance	Frame	Catalog Number
208-240V AC	62 Ohms	0	20BB-DB1-0
	62 Ohms	1 (2-5 Hp)	20BB-DB1-1
	22 Ohms	1 (7.5 HP)	20BB-DB2-1
380-480V AC	22 Ohms	2	20BB-DB1-2
	115 Ohms	0	20BD-DB1-0
	115 Ohms	1	20BD-DB1-1
	62 Ohms	2	20BD-DB1-2

Choose Catalog Code — Factory Installed Option

Factory Installed Option

Drive Input Voltage	Frame	Brake Resistance	Catalog Code
208-240V AC	0	62 Ohms	Y
	1 (2-5 Hp)	62 Ohms	Y
	1 (7.5 HP)	22 Ohms	Y
	2	22 Ohms	Y
380-480V AC	0	115 Ohms	Y
	1	115 Ohms	Y
	2	62 Ohms	Y

Option Selection, Cont'd

Position 13 — EMC Filter

Position 13 identifies the presence of the internal EMC filter (meets second environment CE standards) and provides the option of noise reducing common mode cores. Cores are standard on all drives below 100 HP.

Note: CE certification testing has not been performed on 600V class drives.

20B	D	2P1	A	0	A	Y or N	N	A or B	N	N	O
Drive	Voltage Rating	Rating	Enclosure	HIM	Manuals	Brake	Brake Resistor	Emission	Comm Slot	I/O	Feedback

380-480V AC

No User Installed Kit Available — Leave Default Value “A”

No Catalog Code Option — Standard Installation

Factory Installed Option

Drive Input Voltage	CE Filter	Frame	Common Mode Core	Catalog Code
380-480V AC	0-6	Yes	Yes	A

208-240V AC

No User Installed Kit Available — Leave Default Value “B”

No Catalog Code Option — Standard Installation

Factory Installed Option

Drive Input Voltage	CE Filter	Frame	Common Mode Core	Catalog Code
208-240V AC	Yes	3	Yes	A
208-240v AC	Yes	0-3	No	B
208-240V AC	Yes	4-6	Yes	A
380-480V AC	Yes	0-6	Yes	A

Position 14 — Communication Adapter

Position 14 selects a communications adapter for the drive. Adapters are available for most industrial networks and can be supplied factory installed or as field kits.

20B	D	2P1	A	0	A	Y or N	N	A or B	N	N	O
Drive	Voltage Rating	Rating	Enclosure	HIM	Manuals	Brake	Brake Resistor	Emission	Comm Slot	I/O	Feedback

Default Value “N” — Communication Adapters Not Used

Choose User Installed Kit — Leave Default Value “N”

User Installed Kit

Description	Catalog Number
ControlNet Communication Adapter	20-COMM-C
DeviceNet Communication Adapter	20-COMM-D
Ethernet/IP Communication Adapter	20-COMM-E
Interbus Communication Adapter	20-COMM-I
Profibus Communication Adapter	20-COMM-P
Remote I/O Communication Adapter	20-COMM-R
RS-485 DF1 Communication Adapter	20-COMM-S
Serial Null Modem Adapter	1203-SNM
Smart Self-powered Serial Converter (RS-232) - includes 1203-SFC and 1202-C10 Cables	1203-SSS

Choose Catalog Code — Factory Installed Option

Factory Installed Option

Description	Catalog Code
ControlNet	C
DeviceNet	D
Ethernet/IP	E
HVAC	H
Remote I/O	R
RS-485 DF1	S

Option Selection, Cont'd

Position 15 — I/O Option Card

Position 15 specifies I/O voltage. For Standard Control, user kits include a separate I/O board. For Vector Control, user kits include the entire cassette, including the main control board.

20B	D	2P1	A	0	A	Y or N	N	A or B	N	N	O
Drive	Voltage Rating	Rating	Enclosure	HIM	Manuals	Brake	Brake Resistor	Emission	Comm Slot	I/O	Feedback

Standard Cassette

Choose User Installed Kit — Leave Default Value “N”

Description	Catalog No.
24V DC/AC	20-DA1-A0
115V AC	20-DA1-B0

Choose Catalog Code — Factory Installed Option

Control	Description	Catalog Code
Standard	No I/O	N
Standard	24V DC/AC	A
Standard	115V AC	B

Vector Option

Choose User Installed Kit — Leave Default Value “N”

Control	Description	Catalog Code
Vector with 24V DC	24V DC	20B-VECT-C0
Vector with 115V AC	115V DC	20B-VECT-D0

Choose Catalog Code — Factory Installed Option

Control	Description	Catalog Code
Vector	24V DC	C
Vector	115V DC	D

Note: The Vector Control option utilizes DPI only

Position 16 — Input Cards for Feedback Devices (For Vector Control Only)

Position 16 specifies the input card for the desired feedback device.

20B	D	2P1	A	0	A	Y or N	N	A or B	N	N	O
Drive	Voltage Rating	Rating	Enclosure	HIM	Manuals	Brake	Brake Resistor	Emission	Comm Slot	I/O	Feedback

Default Value “O” — Feedback Option Not Used

Choose User Installed Kit (Vector Control Only) — Leave Default Value “O”

Description	Catalog No.
12V Encoder	20B-ENC-1

Choose Catalog Code — Factory Installed Kit (Vector Control Only)

Factory Installed Kit	
Description	Catalog Code
No Encoder	0
12V Encoder	1

Accessories

Accessory kits are available to supplement the drive installation or tailor the drive to the particular requirements. These may include installation issues, communications structure or others.

Separately-Mounted Human Interface Module (HIM)

Description	Remote (Panel Mount) IP 66, UL Type 4x12 ❶
	Catalog Number
Blank Plate	—
LCD Display, Digital Speed	—
LCD Display, Full Numeric Keypad	20-HIM-C3 ❷
LCD Display, Analog Speed Potentiometer	—
LCD Display, Programmer Only	20-HIM-C5 ❷

- ❶ For indoor use only.
- ❷ Includes a PowerFlex HIM Interface Cable (20-HIM-H10).

Human Interface Module Interface Cables

Description	Catalog Number
Bezel Kit for LCD HIMs, NEMA 1 ❶	20-HIM-B1
PowerFlex HIM Interface Cable, 1 m (39 in.) ❷	20-HIM-H10
Cable Kit (Male-Female) ❸	
0.33 Meters (1.1 Feet)	1202-H03
1 Meter (3.3 Feet)	1202-H10
3 Meter (9.8 Feet)	1202-H30
9 Meter (29.5 Feet)	1202-H90
DPI/SCANport™ One to Two Port Splitter Cable	1203-S03

- ❶ Includes an interface cable (1202-C30) for connection to drive.
- ❷ Required only when HIM is used as handheld or remote.
- ❸ Required in addition to 20-HIM-H10 for distances to a total maximum of 10 Meter (32.8 Feet).

Isolation Transformers

For installations that have specific types of AC supply configurations or require drive protection due to AC line disturbances, isolation transformers are available.

Motor Rating (HP)	240V, 60 Hz, Three-Phase 240V Primary & 240V Secondary	460V, 60 Hz, Three-Phase 460V Primary & 460V Secondary
	IP 32(Nema Type 3R) Catalog Number	IP 32(Nema Type 3R) Catalog Number
0.33	1321-3TH005-AA	1321-3TH005-BB
0.5	1321-3TH005-AA	1321-3TH005-BB
0.75	1321-3TH005-AA	1321-3TH005-BB
1	1321-3TH005-AA	1321-3TH005-BB
1.5	1321-3TH005-AA	1321-3TH005-BB
2	1321-3TH005-AA	1321-3TH005-BB
3	1321-3TH005-AA	1321-3TH005-BB
5	1321-3TH007-AA	1321-3TH007-BB
7.5	1321-3TH011-AA	1321-3TH011-BB
10	1321-3TH014-AA	1321-3TH014-BB
15	1321-3TH020-AA	1321-3TH020-BB
20	1321-3TH027-AA	1321-3TH027-BB
25		1321-3TH034-BB
30		1321-3TH040-BB
40		1321-3TH051-BB
50		1321-3TH063-BB
60		1321-3TH075-BB
75		1321-3TH093-BB
100		1321-3TH118-BB
125		1321-3TH145-BB
150		1321-3TH175-BB

Accessories, Cont'd

Line/Load Reactors

For impedance matching, protection from AC line disturbances or motor protection, reactors are available for both the input and output sides of the drive.

Input and Output Line Reactors[®] - 480V, 60 Hz, Three-Phase

Standard Drive Catalog Number	HP Rating		3% Impedance		5% Impedance	
	Normal Duty	Heavy Duty	IP 00 (Open Style)	IP 11 (Nema Type 1)	IP 00 (Open Style)	IP 11 (Nema Type 1)
			Catalog Number	Catalog Number	Catalog Number	Catalog Number
20BD1P1 ④	0.5	0.33	1321-3R1-C	1321-3RA1-C	1321-3R1-B	1321-3RA1-B
20BD1P1 ⑤	0.5	0.33	1321-3R2-B	1321-3RA2-B	1321-3R2-C	1321-3RA2-C
20BD2P1	1	0.75	1321-3R2-A	1321-3RA2-A	1321-3R2-B	1321-3RA2-B
20BD3P4 ②	2	1.5	1321-3R4-B	1321-3RA4-B	1321-3R4-C	1321-3RA4-C
20BD3P4 ③	2	1.5	1321-3R4-C	1321-3RA4-C	1321-3R4-D	1321-3RA4-D
20BD5P0 ④	3	2	1321-3R4-B	1321-3RA4-B	1321-3R4-C	1321-3RA4-C
20BD5P0 ⑤	3	2	1321-3R8-C	1321-3RA8-C	1321-3R8-D	1321-3RA8-D
20BD8P0 ②	5	3	1321-3R8-B	1321-3RA8-B	1321-3R8-C	1321-3RA8-C
20BD8P0 ③	5	3	1321-3R4-B	1321-3RA4-B	1321-3R4-C	1321-3RA4-C
20BD011 ②	7.5	5	1321-3R12-B	1321-3RA12-B	1321-3R12-C	1321-3RA12-C
20BD011 ③	7.5	5	1321-3R8-B	1321-3RA8-B	1321-3R8-C	1321-3RA8-C
20BD014 ②	10	7.5	1321-3R18-B	1321-3RA18-B	1321-3R18-C	1321-3RA18-C
20BD014 ③	10	7.5	1321-3R12-B	1321-3RA12-B	1321-3R12-C	1321-3RA12-C
20BD022 ②	15	10	1321-3R25-B	1321-3RA25-B	1321-3R25-C	1321-3RA25-C
20BD022 ③	15	10	1321-3R18-B	1321-3RA18-B	1321-3R18-C	1321-3RA18-C
20BD027 ②	20	15	1321-3R35-B	1321-3RA35-B	1321-3R35-C	1321-3RA35-C
20BD027 ③	20	15	1321-3R25-B	1321-3RA25-B	1321-3R25-C	1321-3RA25-C
20BD034	25	20	1321-3R35-B	1321-3RA35-B	1321-3R35-C	1321-3RA35-C
20BD040 ③	30	25	1321-3R35-B	1321-3RA35-B	1321-3R35-C	1321-3RA35-C
20BD040 ⑤	30	25	1321-3R45-B	1321-3RA45-B	1321-3R45-C	1321-3RA45-C
20BD052 ③	40	30	1321-3R45-B	1321-3RA45-B	1321-3R45-C	1321-3RA45-C
20BD052 ⑤	40	30	1321-3R55-B	1321-3RA55-B	1321-3R55-C	1321-3RA55-C
20BD065 ③	50	40	1321-3R55-B	1321-3RA55-B	1321-3R55-C	1321-3RA55-C
20BD065 ②	50	40	1321-3R80-B	1321-3RA80-B	1321-3R80-C	1321-3RA80-C
20BD096 ③	75	60	1321-3R80-B	1321-3RA80-B	1321-3R80-C	1321-3RA80-C
20BD096 ⑦	75	60	1321-3R100-B	1321-3RA100-B	1321-3R100-C	1321-3RA100-C
20BD125 ③	100	75	1321-3R100-B	1321-3RA100-B	1321-3R100-C	1321-3RA100-C
20BD156	100		1321-3R130-B	1321-3RA130-B	1321-3R130-C	1321-3RA130-C
20BD156		125	1321-3R160-B	1321-3RA160-B	1321-3R160-C	1321-3RA160-C
20BD180	125		1321-3R160-B	1321-3RA160-B	1321-3R160-C	1321-3RA160-C
20BD180		150	1321-3R200-B	1321-3RA200-B	1321-3R200-C	1321-3RA200-C

- ① Note the discount schedule difference between 1321 and PowerFlex 700 products.
- ② Normal Duty Input/Output and Heavy Duty Output
- ③ Heavy Duty Input
- ④ Normal Duty/Heavy Duty Input
- ⑤ Normal Duty/Heavy Duty Output
- ⑥ Heavy Duty Input/Output
- ⑦ Normal Duty Input/Output
- ⑧ Input line reactors were sized based on the NEC fundamental motor amps.
Output line reactors were sized based on the VFD rated output currents.

Accessories, Cont'd

Reflected Wave Reduction

Reflected Wave Reduction Device with Common Mode Choke

Description	Used with	Catalog Number (Loose Kit)
380-600V AC, 17.5A IP20 (NEMA Type1)	3.7-7.5 kW (5-10HP)	1204-RWC-17-A

Reflected Wave Reduction Device

Description	Used with	Catalog Number (Loose Kit)
380-575V AC, 9A IP 20 (NEMA Type1)	0.37-3.7 kW (0.5-5HP) 380-460V & 500-600V A Frame Devices	1204-RWR2-09-B

Terminator

Description ❶	Used with	Catalog Number (Loose Kit)
IP65 (NEMA Type4x) Connection Cable Included	0.37-1.5 kW (0.5-2HP) 460V Drives 0.75-597 kW (1-800 HP) 575V Drives	1204-TFA1
	1.5-597 kW (2-800 HP) 460V Drives 0.75-597 kW (1-800 HP) 575 Drives	1204-TFB2

❶ Correct terminator selection is dependent on motor characteristics, cable type and cable length. Refer to publication 1204-1.0 for application details before ordering.

PowerFlex® 700 Standard Packaged Drives

Product Description

PowerFlex 700 Standard Packaged Drives are ideal for global Original Equipment Manufacturers (OEM) and end users with special installation needs. This program simplifies installation and start-up by allowing users to order drive packages that combine operator interface, control, communications and power options in pre-configured assemblies. Designed to meet customer demands for space savings, application flexibility and reliability, Standard Packaged PowerFlex 700 AC drives offer a number of commonly requested pre-engineered options, as well as more complex custom-engineered packages.

Benefits

- Simplified installation and start-up by use of common options assembled at the factory.
- Drive functionality exceeds options offered with a standard drive.
- Multiple packaging options specific to customer needs.
- Pre-engineered options for easy order entry, consistent manufacturing, high quality and reduced deliveries.
- Selectable configurations to meet application requirements.

Features

- Standard PowerFlex 700 AC drives and drive-related options.
- Six pulse and multi-pulse.
- Enclosure options: Type 1, Type 12 (fan and filter or convection/AC), and Type 4 (indoor).
- Pre-engineered options.
- Custom/engineered solutions.
- UL panel recognition from the factory for pre-engineered options.

Options

- Drive Input Protection
- Input/Output Contactors
- Input/Output Line Reactors
- Bypass
- Control Power
- Control Interface and Feedback
- Communication
- Human Interface Module (HIM)
- Motor Interface
- Door Mounted Operator Devices

Please contact your local distributor or sales office for product availability. Standard Packaged Drives offers Quick Ship and pre-engineered programs.

Standard Packaged Drives

Quick Ship Program

Standard Features Include:

- Top of frame 480V PowerFlex 700 Drive (Frames 0-3)
- NEMA Type 1 Enclosure (IP20) — position 8 -A
- Full Numeric LCD HIM - Door Mounted — position 9 -6
- Standard Drive User Manual — position 10 -A
- With Brake IGBT (Frames 0-3) — position 11 -Y
- No Brake Resistor — position 12 -N
- Filter with Common Mode Choke — position 13 -A
- No Communication Module — position 14 -N
- Standard 115V AC I/O — position 15 -B
- No Feedback — position 16 -0
- Quick Ship Option — positions 19 & 20 -QS
- Normal Duty -ND
- No Bypass -B0
- Drive Fault Control Relay -J2
- Drive Run Control Relay -J4
- 115V AC Control Power Transformer -C1
- Fused Disconnect Switch -P6
- Hand/Off/Auto Selector Switch -S1
- Drive Fault Pilot Light -S10
- Control Power On Pilot Light -S13
- Drive Run Pilot Light -S9



Quick Ship Catalog Entry

	Frame	Normal Duty HP	Heavy Duty HP	Type in Catalog Number	Name Plated Catalog Number	Dimensions HxWxD
Type 1 (IP20)	0	7.5	5	21BD011A6AYNANB0NNQS	21BD011A6AYNANB0NNQS-ND-B0-C1-J2-J4-P6-S1-S10-S13-S9	813 x 610 x 422 mm (32 x 24 x 16.6 in.)
	1	15	10	21BD022A6AYNANB0NNQS	21BD022A6AYNANB0NNQS-ND-B0-C1-J2-J4-P6-S1-S10-S13-S9	813 x 610 x 422 mm (32 x 24 x 16.6 in.)
	2	25	20	21BD034A6AYNANB0NNQS	21BD034A6AYNANB0NNQS-ND-B0-C1-J2-J4-P6-S1-S10-S13-S9	965 x 610 x 422 mm (38 x 24 x 16.6 in.)
	3	50	40	21BD065A6AYNANB0NNQS	21BD065A6AYNANB0NNQS-ND-B0-C1-J2-J4-P6-S1-S10-S13-S9	965 x 762 x 422 mm (38 x 30 x 16.6 in.)

Note: Initially, each customer ID is limited to 3 units per week, per catalog string.

Additional Options

- Drive Mounted ControlNet™ Communication Module -GC
- Drive Mounted DeviceNet™ Communication Module -GD
- Drive Mounted Profibus Communication Module -GP
- Drive Mounted RIO -GR
- Panel Mounted Analog Input Isolator 0-10V -N1
- Panel Mounted Analog Input Isolator 4-20 mA -N2
- Panel Mounted Analog Isolator 0-10V -N3

Option Notes:

Lead time increases from 5 business day to 10 business days.

Orders requiring selection options should be entered the same as a pre-engineered Passport string:
21BD011A6AYNANCB0NNNN-ND-B0-C1-J2-J4-N1-P6-S1-S10-S13-S9

Standard Packaged Drives

Pre-Engineered Program

NEMA Type 1

- Panel Mount Drive
- Welded Construction for Wall Mount
- Modular Construction for Floor Standing
- 240V/480V/600V Ratings

NEMA Type 12 Fan & Filter

- Panel Mount Drive
- Welded Construction for Wall Mount
- Modular Construction for Floor Standing
- 240V/480V/600V Ratings

All Enclosure Types

- Drive Input Protection Options
- Input/Output Contactors
- Bypass Options
- Input/Output Line Reactor Options
- 115V Control Power Options
- Control Interface and Feedback Options
- Human Interface Modules
- Motor Interface Options
- Operator Devices
- Drawing and Test Options



Description and Approximate Dimensions

Frame			Approximate Dimensions H x W x D	Style
Catalog Code "A" without Line Reactors	Catalog Code "A" with Line Reactors	Catalog Code "H" with or without Line Reactors		
0 & 1	—	—	813 x 610 x 422 mm (32 x 24 x 16.6 in.)	Wall Mount
2	0	0	965 x 762 x 422 mm (38 x 30 x 16.6 in.)	Wall Mount
3	—	—	965 x 762 x 422 mm (38 x 30 x 16.6 in.)	Wall Mount
4	—	—	1270 x 762 x 422 mm (50 x 30 x 16.6 in.)	Wall Mount
—	1 & 2	1 & 2	1118 x 610 x 523mm (44 x 24 x 20.6 in.)	Wall Mount
—	3	3	1270 x 762 x 523 mm (50 x 30 x 20.6 in.)	Wall Mount
—	4	4	1422 x 914 x 622 mm (56 x 36 x 24.5 in.)	Wall Mount
5	5	5	2200 x 800 x 600 mm (86.6 x 31.5 x 23.6 in.)	Floor Standing
6	6	6	2200 x 1000 x 600 mm (86.6 x 39.5 x 23.6 in.)	Floor Standing

Custom/OEM Specific Package Program

- Meets customer-specific specifications
- All voltage ratings are available

The Allen-Bradley Standard Packaged Drives Program allows users to order PowerFlex 700 drive packages that exceed the options offered with a standard drive product. Users can choose from an option list that includes control, power, packaging and documentation to meet unique application demands. The program provides different physical pre-engineered package sizes based upon environmental and option mounting requirements.

Installation Considerations

Power Wiring

The PowerFlex 700 has the following built in protective features to help simplify installation:

- Ground fault protection during start up and running ensures reliable operation
- Electronic motor overload protection increases motor life
- Removable MOV to ground and common mode capacitors to ground ensure compatibility with ungrounded systems
- 6 kV transient protection provides increased robustness for 380-480V system voltages

There are many other factors that must be considered for optimal performance in any given application. The block diagram below highlights the primary installation considerations. Consult the *PowerFlex Reference Manual* available online at www.ab.com/manuals/dr, for detailed recommendations on input power conditioning, CE conformance (EMC filtering), dynamic braking, reflected wave protection, motor cable types and motor cable distances.

The block diagram below also provides direction on other installation issues and concerns.

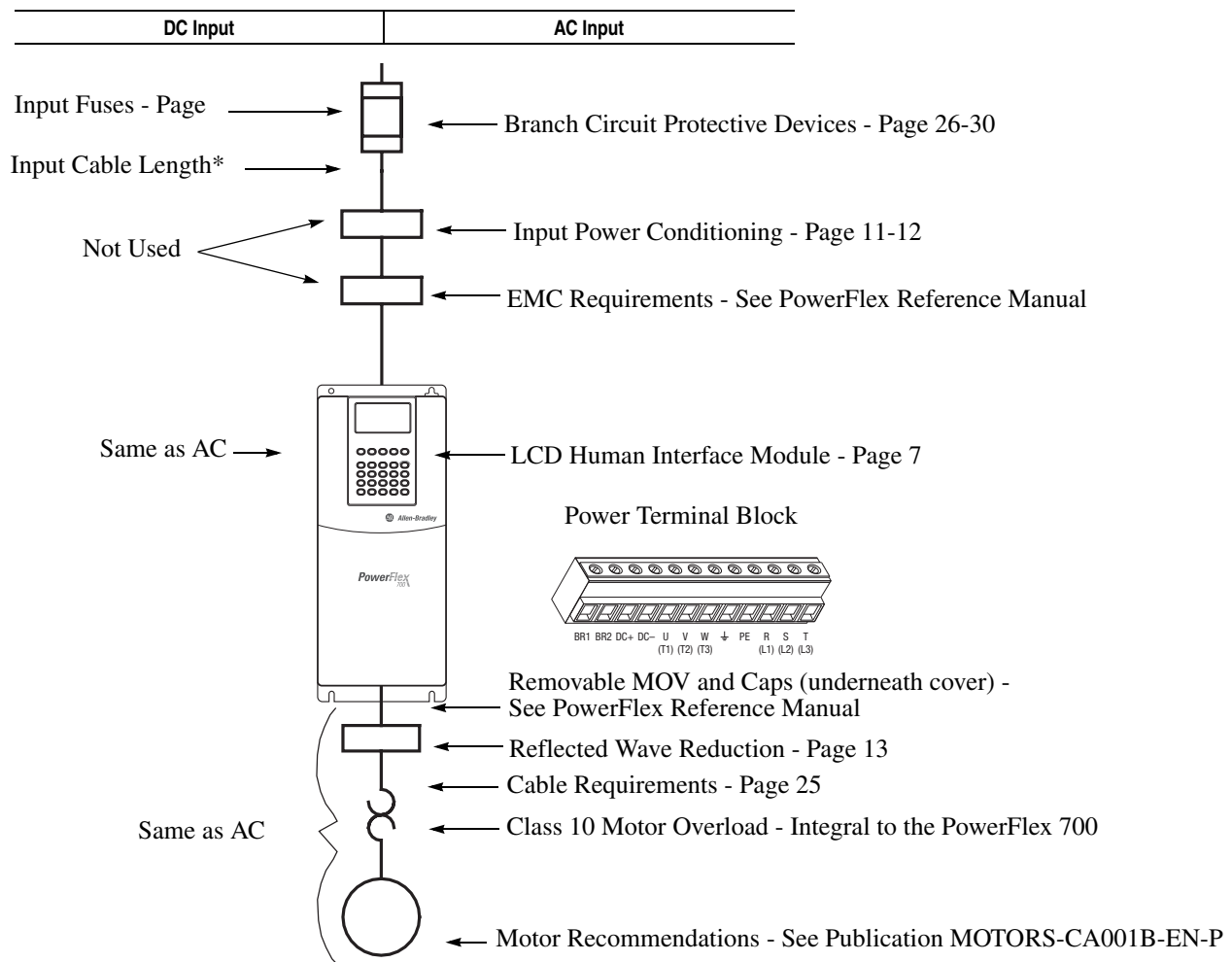

* Input Cable Length is limited. See Publication 20B-UM001x-EN-P for further details.

Installation Considerations

Terminals

Terminal Block Specifications

No.	Name	Frame	Description	Wire Size Range (1)		Torque	
				Maximum	Minimum	Maximum	Recommended
①	Power Terminal Block	0 & 1	All power terminals	4.0 mm ² (10 AWG)	0.5 mm ² (22 AWG)	1.7 N-m (15 lb.-in.)	0.8 N-m (7 lb.-in.)
		2	All power terminals	10.0 mm ² (6 AWG)	0.8 mm ² (18 AWG)	1.7 N-m (15 lb.-in.)	1.4 N-m (12 lb.-in.)
		3	All power terminals	25.0 mm ² (3 AWG)	2.5 mm ² (14 AWG)	3.6 N-m (32 lb.-in.)	1.8 N-m (16 lb.-in.)
			All power terminals	10.0 mm ² (6 AWG)	0.8 mm ² (18 AWG)	1.7 N-m (15 lb.-in.)	1.4 N-m (12 lb.-in.)
		4	All power terminals	35.0 mm ² (1/0 AWG)	10 mm ² (8 AWG)	2.9 N-m (24 lb.-in.)	2.9 N-m (24 lb.-in.)
		5 (75 HP)(2)	PS-, PS+	35.0 mm ² (1/0 AWG)	2.5 mm ² (14 AWG)	3.6 N-m (32 lb.-in.)	3.6 N-m (32 lb.-in.)
			PE	35.0 mm ² (1/0 AWG)	16.0 mm ² (6 AWG)	5 N-m (44 lb.-in.)	5 N-m (44 lb.-in.)
		5 (100 HP) (2)	PS-, PS+	70.0 mm ² (3/0 AWG)	16.0 mm ² (4 AWG)	15 N-m (133 lb.-in.)	15 N-m (133 lb.-in.)
			BR1, 2, terminals	35.0 mm ² (1/0 AWG)	2.5 mm ² (14 AWG)	3.6 N-m (32 lb.-in.)	3.6 N-m (32 lb.-in.)
			PE	35.0 mm ² (1/0 AWG)	16.0 mm ² (6 AWG)	5 N-m (44 lb.-in.)	5 N-m (44 lb.-in.)
6	DC+, DC-, BR1, BR2, PE and motor connections	70.0 mm ² (250 MCM)	2.5 mm ² (14 AWG)	6 N-m (52 lb.-in.)	6 N-m (52 lb.-in.)		
②	SHLD Terminal	0-6	Terminating point for wiring shields	—	—	1.6 N-m (14 lb.-in.)	1.6 N-m (14 lb.-in.)
③	AUX Terminal Block	0-4	Auxiliary Control Voltage (3)	1.3 mm ² (16 AWG)	0.2 mm ² (24 AWG)	—	—
		5-6		4.0 mm ² (10 AWG)	0.5 mm ² (22 AWG)	0.6 N-m (5.3 lb.-in.)	0.6 N-m (5.3 lb.-in.)
④	I/O Terminal Block	5-6	Signal and control connections	2.1 mm ² (14 AWG)	0.30 mm ² (22 AWG)	1.36 N-m (12 lb.-in.)	1.36 N-m (12 lb.-in.)
⑤	Encoder Terminal Block (4)	5-6	Encoder power and signal connections	0.75 mm ² (18 AWG)	0.196 mm ² (24 AWG)	1.36 N-m (12 lb.-in.)	1.36 N-m (12 lb.-in.)
⑥	Fan Terminal Block	5-6	User Supplied Fan Voltage	4.0 mm ² (10 AWG)	0.5 mm ² (22 AWG)	0.6 N-m (5.3 lb.-in.)	0.6 N-m (5.3 lb.-in.)

Notes:

- (1) Maximum/minimum sizes that the terminal block will accept - these are not recommendations.
- (2) Not all terminals present on all drives.
- (3) External control power:
UL Installation - 300V DC, ±10%, Non UL Installation - 270-600V DC, ±10%.
0-3 Frame - 40 W, 165 mA, 5 Frame - 80 W, 90 mA
- (4) Maximum/minimum sizes that the terminal block will accept - these are not recommendations.

Terminal	Description	Notes
BR1	DC Brake (+)	Dynamic Brake Resistor Connection (+)
BR2	DC Brake (-)	Dynamic Brake Resistor Connection (-)
DC+	DC Bus (+)	DC Input Power or Dynamic Brake Chopper
DC-	DC Bus (-)	DC Input Power or Dynamic Brake Chopper
PE	PE Ground	Refer to page 19 for location on 3 Frame drives
⊕	Motor Ground	Refer to page 19 for location on 3 Frame drives
U	U (T1)	To motor
V	V (T2)	To motor
W	W (T3)	To motor
R	R (L1)	AC Line Input Power
S	S (L2)	AC Line Input Power
T	T (L3)	AC Line Input Power

Installation Considerations

Terminals, Cont'd

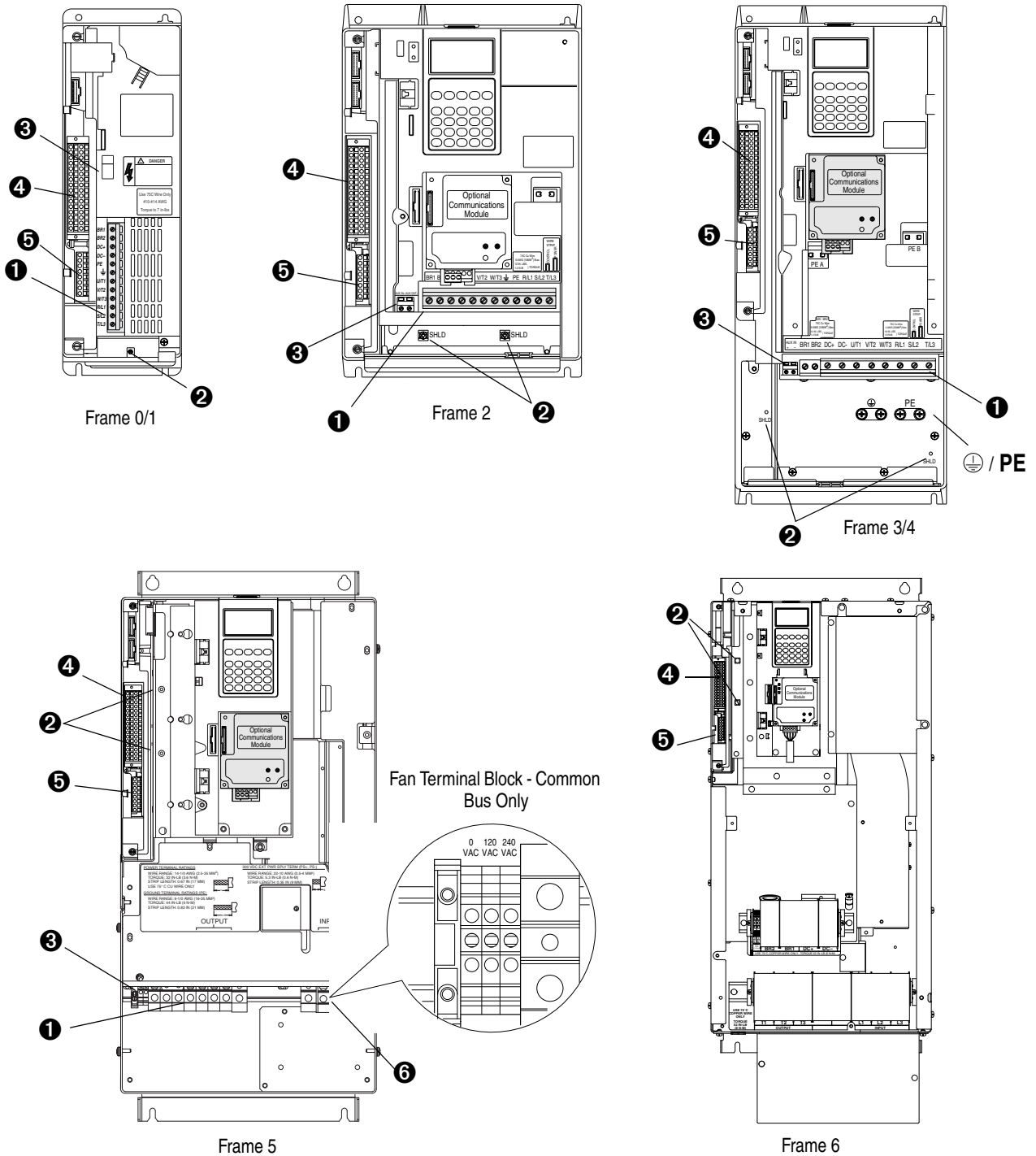

Fan VA Rating - Common Bus Only

Frame	Rating (at any voltage)
5	100 VA
6	138 VA

Installation Considerations

Terminals, Cont'd

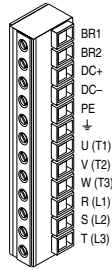

Frames 0 & 1

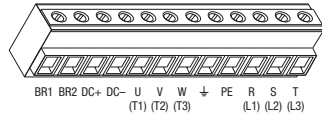

Frame 2

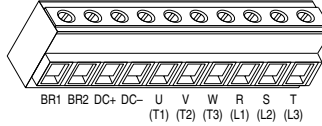

Frame 3 & 4

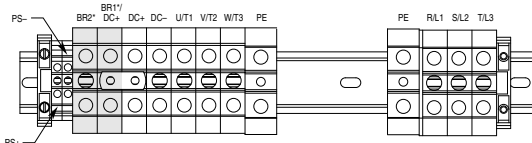

Frame 5 - 75 HP, 480V (55kW, 400V) Normal Duty Drive

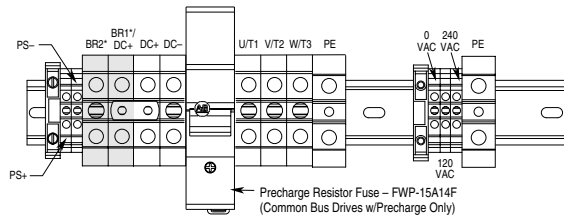

Frame 5 - 100 HP, 480V Normal Duty Drive

* Terminals BR1 & BR2 will only be present on drives ordered with the Brake Option.

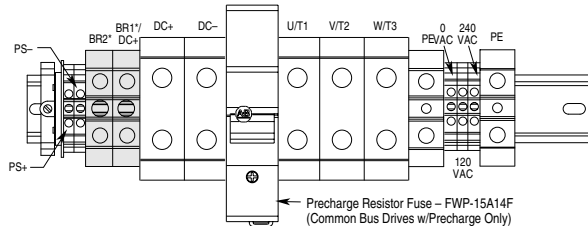

Frame 5 - Common Bus

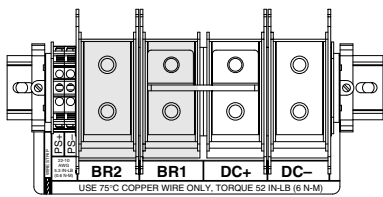

Terminals BR1 & BR2 will only be present on drives ordered with the Brake Option.

Common Mode Capacitor
MOV Jumpers

Input Filter Capacitor

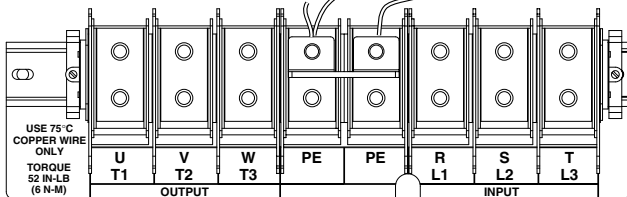

Frame 6

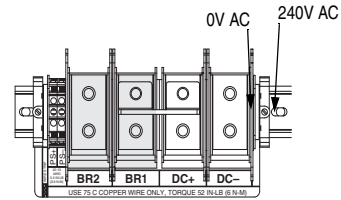

Frame 6 - Common Bus

Installation Considerations

Control Terminals

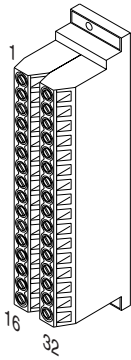
Standard Control Option	No.	Signal	Factory Default	Description	Related Param.		
	1	Anlg Volts In 1 (-)	(2)	Isolated (3), bipolar, differential, $\pm 10V$, 11 bit & sign, 88k ohm input impedance.	320 - 327		
	2	Anlg Volts In 1 (+)					
	3	Anlg Volts In 2 (-)	(2)	Isolated (4), bipolar, differential, $\pm 10V$, 11 bit & sign, 88k ohm input impedance.			
	4	Anlg Volts In 2 (+)					
	5	Pot Common	-		For (+) and (-) 10V pot references.		
	6	Anlg Volts Out 1 (-)	(2)		Bipolar, $\pm 10V$, 11 bit & sign, 2k ohm minimum load.	340 - 344	
	7	Anlg Volts Out 1 (+)					
	8	Anlg Current Out 1 (-)	(2)		4-20mA, 11 bit & sign, 400 ohm maximum load.		
	9	Anlg Current Out 1 (+)					
	10	Reserved for Future Use					
	11	Digital Out 1 - N.C. (1)		Fault	Max. Resistive Load: 240V AC/30V DC - 1200VA, 150W Max. Current: 5A, Min. Load: 10mA Max. Inductive Load: 240V AC/30V DC - 840VA, 105W Max. Current: 3.5A, Min. Load: 10mA	380 - 387	
	12	Digital Out 1 Common					
	13	Digital Out 1 - N.O. (1)		NOT Fault			
	14	Digital Out 2 - N.C. (1)		NOT Run			
	15	Digital Out 2 Common					
	16	Digital Out 2 - N.O. (1)		Run			
	17	Anlg Current In 1 (-)	(2)		Isolated (3), 4-20mA, 11 bit & sign, 124 ohm input impedance.	320 - 327	
	18	Anlg Current In 1 (+)					
	19	Anlg Current In 2 (-)	(2)		Isolated (4), 4-20mA, 11 bit & sign, 124 ohm input impedance.		
	20	Anlg Current In 2 (+)					
	21	-10V Pot Reference	-		2k ohm minimum.		
	22	+10V Pot Reference	-				
	23	Reserved for Future Use					
	24	+24VDC (5)	-		Drive supplied logic input power. (5)		
	25	Digital In Common	-				
	26	24V Common (5)	-		Common for internal power supply.		
	27	Digital In 1		Stop - CF	115V AC, 50/60 Hz - Opto isolated	361 - 366	
	28	Digital In 2		Start	Low State: less than 30V AC		
	29	Digital In 3		Jog	High State: greater than 100V AC		
	30	Digital In 4		Speed Sel 1	24V AC/DC, 50/60 Hz - Opto isolated		
	31	Digital In 5		Speed Sel 2	Low State: less than 5V AC/DC		
	32	Digital In 6		Speed Sel 3	High State: greater than 20V AC/DC 11.2 mA DC		

Notes:

- (1) Contacts in unpowered state. Any relay programmed as Fault or Alarm will energize (pick up) when power is applied to drive and deenergize (drop out) when a fault or alarm exists. Relays selected for other functions will energize only when that condition exists and will deenergize when condition is removed.
- (2) These inputs/outputs are dependant on a number of parameters. See "Related Parameters."
- (3) Differential Isolation - External source must be maintained at less than 160V with respect to PE. Input provides high common mode immunity.
- (4) Differential Isolation - External source must be less than 10V with respect to PE.
- (5) 150mA maximum Load. Not present on 115V versions.

Installation Considerations

Control Terminals, Cont'd

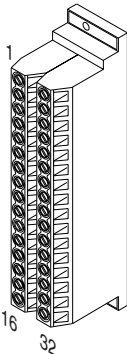
Vector Control Option	No.	Signal	Factory Default	Description	Related Param.		
	1	Analog In 1 (-) (1)	(2)	Isolated (3), bipolar, differential, $\pm 10V/4-20mA$, 11 bit & sign, 88k ohm input impedance. For 4-20mA, a jumper must be installed at terminals 17 & 18 (or 19 & 20).	320 - 327		
	2	Analog In 1 (+) (1)					
	3	Analog In 2 (-) (1)					
	4	Analog In 2 (+) (1)					
	5	Pot Common	-		For (+) and (-) 10V pot references.		
	6	Analog Out 1 (-)	(2)	Bipolar (current output is not bipolar), $\pm 10V/4-20mA$, 11 bit & sign, voltage mode - limit current to 5 mA. Current mode - max. load resistance is 400 ohms.	340 - 347		
	7	Analog Out 1 (+)					
	8	Analog Out 2 (-)					
	9	Analog Out 2 (+)					
	10	Reserved for Future Use					
	11	Digital Out 1 - N.C. (4)	Fault	Max. Resistive Load: 240V AC/30V DC - 1200VA, 150W Max. Current: 5A, Min. Load: 10mA	380 - 391		
	12	Digital Out 1 Common					
	13	Digital Out 1 - N.O. (4)	NOT Fault				
	14	Digital Out 2 - N.C. (4)	NOT Run	Max. Inductive Load: 240V AC/30V DC - 840VA, 105W Max. Current: 3.5A, Min. Load: 10mA			
	15	Digital Out 2/3 Com.					
	16	Digital Out 3 - N.O. (4)	Run				
	17	Current In Jumper (1) - Analog In 1			Placing a jumper across terminals 17 & 18 (or 19 & 20) will configure that analog input for current.		
	18	Current In Jumper (1) - Analog In 2					
	19	Current In Jumper (1) - Analog In 2					
	20						
	21	-10V Pot Reference	-		2k ohm minimum load.		
	22	+10V Pot Reference	-				
	23	Reserved for Future Use					
	24	+24VDC (5)	-		Drive supplied logic input power. (5)		
	25	Digital In Common	-				
	26	24V Common (5)	-		Common for internal power supply.		
	27	Digital In 1	Stop - CF	Speed Sel 1	115V AC, 50/60 Hz - Opto isolated Low State: less than 30V AC High State: greater than 100V AC 24V DC - Opto isolated Low State: less than 5V DC High State: greater than 20V DC 11.2 mA DC	361 - 366	
	28	Digital In 2	Start				
	29	Digital In 3	Jog				
	30	Digital In 4	Speed Sel 1				
	31	Digital In 5	Speed Sel 2				
	32	Digital In 6/Hardware Enable	Speed Sel 3				

Notes:

- (1) **Important:** 4-20mA operation requires a jumper at terminals 17 & 18 (or 19 & 20). Drive damage may occur if jumper is not installed.
- (2) These inputs/outputs are dependant on a number of parameters (see "Related Parameters").
- (3) Differential Isolation - External source must be maintained at less than 160V with respect to PE. Input provides high common mode immunity.
- (4) Contacts in unpowered state. Any relay programmed as Fault or Alarm will energize (pick up) when power is applied to drive and deenergize (drop out) when a fault or alarm exists. Relays selected for other functions will energize only when that condition exists and will deenergize when condition is removed.
- (5) 150mA maximum Load. Not present on 115V versions.

Installation Considerations

Control Terminals Cont'd

Encoder Terminal Block (Vector Control Option Only)

Encoder Terminal Designations

No.	Description (refer to page 40 for encoder specifications)	
8	+12V DC Power	Internal power source 250 mA.
7	+12V DC Return (Common)	
6	Encoder Z (NOT)	Pulse, marker or registration input. (1)
5	Encoder Z	
4	Encoder B (NOT)	Quadrature B input.
3	Encoder B	
2	Encoder A (NOT)	Single channel or quadrature A input.
1	Encoder A	

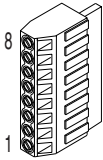

(1) Z channel can be used as a pulse input while A & B are used for encoder.

Sample Encoder Wiring

I/O	Connection Example	I/O	Connection Example
Encoder Power –Internal Drive Power Internal (drive) 12V DC, 250mA		Encoder Power –External Power Source	
Encoder Signal –Single-Ended, Dual Channel		Encoder Signal –Differential, Dual Channel	

I/O Wiring Examples – Standard & Vector Control Options

Input/Output	Connection Example	Required Parameter Changes
Potentiometer Unipolar Speed Reference (1) 10k Ohm Pot. Recommended (2k Ohm Minimum)		² Adjust Scaling: Parameters 91/92 and 325/326 ² View Results: Parameter 002
Joystick Bipolar Speed Reference (1) ±10V Input		² Set Direction Mode: Parameter 190 = "1, Bipolar" ² Adjust Scaling: Parameters 91/92 and 325/326 ² View Results: Parameter 002
Analog Input Bipolar Speed Reference ±10V Input		² Set Direction Mode: Parameter 190 = "1, Bipolar" ² Adjust Scaling: Parameters 91/92 and 325/326 ² View Results: Parameter 002
Analog Voltage Input Unipolar Speed Reference 0 to +10V Input		² Configure Input with parameter 320 ² Adjust Scaling: Parameters 91/92 and 325/326 ² View results: Parameter 002

Specifications

Input/Output	Connection Example	Required Parameter Changes
Analog Current Input Unipolar Speed Reference Standard 4-20 mA Input		² Configure Input for Current: Parameter 320, Bit 1 = "1, Current" ² Adjust Scaling: Parameters 91/92 and 325/326 ² View Results: Parameter 002
Analog Current Input Unipolar Speed Reference Vector 4-20 mA Input		² Configure Input for Current: Parameter 320 and add jumper at appropriate terminals ² Adjust Scaling: Parameters 91/92 and 325/326 ² View results: Parameter 002
Analog Output ±10V, 4-20 mA Bipolar +10V Unipolar (shown) <u>Standard Control</u> 4-20 mA Unipolar (use term. 8 & 9)		² Configure with Parameter 340 ² Select Source Value: Parameter 384, [Digital Out1 Sel] ² Adjust Scaling: Parameters 343/344
2-Wire Control Non-Reversing (2) 24V DC internal supply		² Disable Digital Input:#1: Parameter 361 = "0, Unused" ² Set Digital Input #2: Parameter 362 = "7, Run" ² Set Direction Mode: Parameter 190 = "0, Unipolar"
2-Wire Control Reversing (2) External supply (I/O Board dependent)		² Set Digital Input:#1: Parameter 361 = "8, Run Forward" ² Set Digital Input #2: Parameter 362 = "9, Run Reverse"
3-Wire Control Internal supply		² No Changes Required
3-Wire Control External supply (I/O Board dependent). Requires 3-wire functions only ([Digital In1 Sel]). Using 2-wire selections will cause a type 2 alarm.		² No Changes Required
Digital Output Relays shown in powered state with drive faulted. See pages 20 & 21. <u>Standard Control</u> 1 relay at terminals 14-16. <u>Vector Control</u> 2 relays at terminals 14-16.		² Select Source to Activate: Parameters 380/384
Enable Input		² <u>Standard Control</u> Configure with parameter 366 ² <u>Vector Control</u> Configure with parameter 366 For dedicated hardware Enable: Remove Jumper J10 (see page 20)

Notes:

- (1) Refer to *PowerFlex 700 User Manual* for more information on bipolar wiring.
- (2) **Important:** Programming inputs for 2 wire control deactivates all HIM Start buttons.

Specifications

Cable Recommendations

Cable Types Acceptable for 200-600 Volt Installations

A variety of cable types are acceptable for drive installations. For many installations, unshielded cable is adequate, provided it can be separated from sensitive circuits. As an approximate guide, allow a spacing of 0.3 meters (1 foot) for every 10 meters (32.8 feet) of length. In all cases, long parallel runs must be avoided. Do not use cable with an insulation thickness less than or equal to 15 mils (0.4mm/0.015 in.). See table below.

Unshielded

THHN, THWN or similar wire is acceptable for drive installation in dry environments provided adequate free air space and/or conduit fill rates limits are provided. **Do not use THHN or similarly coated wire in wet areas.** Any wire chosen must have a minimum insulation thickness of 15 Mils and should not have large variations in insulation concentricity.

Shielded/Armored Cable

Shielded cable contains all of the general benefits of multi-conductor cable with the added benefit of a copper braided shield that can contain much of the noise generated by a typical AC drive. Strong consideration for shielded cable should be given in installations with sensitive equipment such as weigh scales, capacitive proximity switches and other devices that may be affected by electrical noise in the distribution system. Applications with large numbers of drives in a similar location, imposed EMC regulations or a high degree of communications/ networking are also good candidates for shielded cable.

Shielded cable may also help reduce shaft voltage and induced bearing currents for some applications. In addition, the increased impedance of shielded cable may help extend the distance that the motor can be located from the drive without the addition of motor protective devices such as terminator networks. Refer to *Reflected Wave* in “Wiring and Grounding Guidelines for PWM AC Drives,” publication DRIVES-IN001.

Consideration should be given to all of the general specifications dictated by the environment of the installation, including temperature, flexibility, moisture characteristics and chemical resistance. In addition, a braided shield should be included and be specified by the cable manufacturer as having coverage of at least 75%. An additional foil shield can greatly improve noise containment.

A good example of recommended cable is Belden® 295xx (xx determines gauge). This cable has four (4) XLPE insulated conductors with a 100% coverage foil and an 85% coverage copper braided shield (with drain wire) surrounded by a PVC jacket.

Other types of shielded cable are available, but the selection of these types may limit the allowable cable length. Particularly, some of the newer cables twist 4 conductors of THHN wire and wrap them tightly with a foil shield. This construction can greatly increase the cable charging current required and reduce the overall drive performance. Unless specified in the individual distance tables as tested with the drive, these cables are not recommended and their performance against the lead length limits supplied is not known.

Location	Rating/Type	Description
Standard (Option 1)	600V, 90° C (194° F) XHHW2/RHW-2 Anixter B209500-B209507, Belden 29501-29507, or equivalent	<ul style="list-style-type: none">• Four tinned copper conductors with XLP insulation.• Copper braid/aluminum foil combination shield and tinned copper drain wire.• PVC jacket.
Standard (Option 2)	Tray rated 600V, 90° C (194° F) RHH/RHW-2 Anixter OLF-7xxxx or equivalent	<ul style="list-style-type: none">• Three tinned copper conductors with XLPE insulation.• 5 mil single helical copper tape (25% overlap min.) with three bare copper grounds in contact with shield.• PVC jacket.
Class I & II; Division I & II	Tray rated 600V, 90° C (194° F) RHH/RHW-2 Anixter 7V-7xxxx-3G or equivalent	<ul style="list-style-type: none">• Three bare copper conductors with XLPE insulation and impervious corrugated continuously welded aluminum armor.• Black sunlight resistant PVC jacket overall.• Three copper grounds on #10 AWG and smaller.

Power Ratings, Branch Circuit Protection and Power Dissipation

208 Volt AC Input Recommended Protection Devices (See page 29 for Notes)

Drive Catalog Number	HP Rating ND	Input Ratings kVA Amps	Output Amps		Dual Element Time Delay Fuse		Non-Time Delay Fuse	Circuit Breaker (3) Max. (10)	Motor Circuit Protector (4) Max. (10)	140M Motor Starter with Adjustable Current Range (5) (6) Available Catalog Numbers (7)					
			Cont.	1 Min.	3 Sec.	Min. (1)					Max. (2)				
208 Volt AC Input															
20BB2P2	0	0.5	0.33	1.9	0.7	2.5	2.8	3	3	10	15	3	140M-C2E-B25	140M-D8E-B25	-
20BB4P2	0	1	0.75	3.7	1.3	4.8	5.6	7.0	6	10	15	7	140M-C2E-B63	140M-D8E-B63	-
20BB6P8	1	2	1.5	6.8	2.4	7.8	10.4	13.8	10	15	30	15	140M-C2E-C10	140M-D8E-C10	140M-F8E-C10
20BB9P6	1	3	2	9.5	3.4	11	12.1	17	12	20	40	15	140M-C2E-C16	140M-D8E-C16	140M-F8E-C16
20BB015	1	5	3	15.7	5.7	17.5	19.3	26.3	20	35	70	30	140M-C2E-C20	140M-D8E-C20	140M-F8E-C20
20BB022	1	7.5	5	23.0	8.3	25.3	27.8	38	30	50	100	30	140M-C2E-C25	140M-D8E-C25	140M-F8E-C25
20BB028	2	10	7.5	29.6	10.7	32.2	38	50.6	40	70	125	50	-	-	140M-F8E-C32
20BB042	3	15	10	44.5	16.0	48.3	53.1	72.5	60	100	60	100	-	-	140M-F8E-C45
20BB062	3	20	15	51.5	17.1	56	64	86	80	125	200	100	-	-	140M-CMN-6300
20BB070	4	25	20	72	25.9	78.2	93	124	90	175	300	100	-	-	140M-CMN-9000
20BB080	4	30	25	84.7	30.5	92	117	156	110	200	350	150	-	-	140M-CMN-9000
20BB104	5	40	-	113	40.7	120	132	175	150	250	475	350	-	-	-
				30	84.7	30.5	92	138	175	200	350	150	-	-	140M-CMN-9000
20BB130	5	50	-	122	44.1	130	143	175	175	275	500	250	-	-	-
				40	98	35.3	104	156	175	225	400	300	-	-	-
20BB154	6	60	-	167	60.1	177	195	266	225	350	500	250	-	-	-
				50	141	50.9	150	225	300	300	500	450	-	-	-
20BB192	6	75	-	208	75.0	221	243	308	300	450	600	400	-	-	-
				60	167	60.1	177	266	308	350	500	250	-	-	-

240 Volt AC Input Recommended Protection Devices (See page 29 for Notes)

Drive Catalog Number	HP Rating ND	Input Ratings kVA Amps	Output Amps		Dual Element Time Delay Fuse		Non-Time Delay Fuse	Circuit Breaker (3) Max. (10)	Motor Circuit Protector (4) Max. (10)	140M Motor Starter with Adjustable Current Range (5) (6) Available Catalog Numbers (7)					
			Cont.	1 Min.	3 Sec.	Min. (1)					Max. (2)				
240 Volt AC Input															
20BB2P2	0	0.5	0.33	1.7	0.7	2.2	2.4	3	3	10	15	3	140M-C2E-B25	140M-D8E-B25	-
20BB4P2	0	1	0.75	3.3	1.4	4.2	4.8	6.4	5	8	15	7	140M-C2E-B63	140M-D8E-B63	-
20BB6P8	1	2	1.5	5.9	2.4	6.8	9	12	10	15	25	15	140M-C2E-C10	140M-D8E-C10	140M-F8E-C10
20BB9P6	1	3	2	8.3	3.4	9.6	10.6	14.4	12	20	35	15	140M-C2E-C10	140M-D8E-C10	140M-F8E-C10
20BB015	1	5	3	13.7	5.7	15.3	16.8	23	20	30	60	30	140M-C2E-C16	140M-D8E-C16	140M-F8E-C16
20BB022	1	7.5	5	19.9	8.3	22	24.2	33	25	50	80	30	140M-C2E-C25	140M-D8E-C25	140M-F8E-C25
20BB028	2	10	7.5	25.7	10.7	28	33	44	35	60	100	50	-	-	140M-F8E-C32
20BB042	3	15	10	38.5	16.0	42	46.2	63	50	90	150	50	-	-	140M-F8E-C45
20BB052	3	20	15	47.7	19.8	52	63	80	60	100	200	100	-	-	140M-CMN-6300
20BB070	4	25	20	64.2	26.7	70	78	105	90	150	275	100	-	-	140M-CMN-9000
20BB080	4	30	25	73.2	30.5	80	105	140	100	180	300	100	-	-	140M-CMN-9000
20BB104	5	40	-	98	40.6	104	115	175	125	225	400	150	-	-	-
				30	73	30.5	80	120	160	100	300	100	-	-	140M-CMN-9000
20BB130	5	50	-	122	50.7	130	143	175	175	275	500	250	-	-	-
				40	98	40.6	104	156	175	225	400	300	-	-	-
20BB154	6	60	-	145	60.1	154	231	308	200	300	600	250	-	-	-
				50	122	50.7	130	195	260	175	375	250	-	-	-
20BB192	6	75	-	180	74.9	192	211	288	225	400	600	250	-	-	-
				60	145	60.1	154	308	200	300	600	450	-	-	-

Specifications

Power Ratings, Branch Circuit Protection and Power Dissipation, Cont'd

400 Volt AC Input Recommended Protection Devices (See page 29 for Notes)

Drive Catalog Number	kW Rating	Input Ratings		Output Amps		Dual Element Time Delay Fuse		Non-Time Delay Fuse		Circuit Breaker (3)	Motor Circuit Protector (4)	140M Motor Starter with Adjustable Current Range (5) (6)	Power Dissipation Watts	
		ND	HD	Cont.	1 Min.	3 Sec.	Min. (1)	Max. (2)	Min. (1)					Max. (2)
400 Volt AC Input														
20BC1P3	0	0.37	0.25	1.1	0.77	1.3	1.4	1.9	3	3	3	140M-C2E-B16	53	
20BC2P1	0	0.75	0.55	1.8	1.3	2.1	2.4	3.2	3	3	3	140M-C2E-B25	63	
20BC3P5	0	1.5	0.75	3.2	2.2	3.5	4.5	6.0	6	7	7	140M-C2E-B40	76	
20BC5P0	0	2.2	1.5	4.6	3.2	5.0	5.5	7.5	6	10	6	140M-C2E-B63	93	
20BC8P7	0	4	2.2	7.9	5.5	8.7	9.9	13.2	15	17.5	15	140M-C2E-C10	164	
20BC011	0	5.5	4	10.8	7.5	11.5	13	17.4	15	25	15	140M-C2E-C16	194	
20BC015	1	7.5	5.5	14.4	10.0	15.4	17.2	23.1	20	30	20	140M-C2E-C20	218	
20BC022	1	11	7.5	20.6	14.3	22	24.2	33	30	45	30	140M-C2E-C25	326	
20BC030	2	15	11	28.4	19.7	30	33	45	35	60	35	140M-F8E-C32	394	
20BC037	2	18.5	15	35.0	24.3	37	45	60	45	80	45	140M-F8E-C45	441	
20BC043	3	22	18.5	40.7	28.2	43	56	74	60	90	60	140M-F8E-C45	459	
20BC056	3	30	22	53	36.7	56	64	86	70	125	70	140M-F8E-C45	610	
20BC072	3	37	30	68.9	47.8	72	84	112	90	150	90	140M-F8E-C45	717	
20BC085 (8)	4	45	—	81.4	56.4	85	94	128	110	200	110	140M-F8E-C45	717	
				37	68.9	47.8	72	108	144	90	175	90	140M-F8E-C45	974
20BC105	5	55	—	100.5	69.6	105	116	158	125	225	125	140M-F8E-C45	974	
				45	81.4	56.4	85	128	170	110	175	110	140M-F8E-C45	1060
20BC125	5	55	—	121.1	83.9	125	138	163	150	275	150	140M-F8E-C45	1021	
				45	91.9	63.7	96	144	168	125	200	125	140M-F8E-C45	1146
20BC140	6	75	—	149	103	140	154	210	200	300	200	140M-F8E-C45	1060	
				55	111	76	105	158	210	150	225	150	140M-F8E-C45	NA
20BC170	6	90	—	164	126	170	187	255	250	375	250	140M-F8E-C45	NA	
				75	136	103	140	210	280	200	300	200	140M-F8E-C45	NA
20BC205 (9)	6	110	—	199	148	205	220	289	250	450	250	140M-F8E-C45	NA	
				90	164	126	170	255	313	250	375	250	140M-F8E-C45	NA

Power Ratings, Branch Circuit Protection and Power Dissipation, Cont'd

480 Volt AC Input Recommended Protection Devices (See page 29 for Notes)

Drive Catalog Number	HP Rating		Input Ratings		Output Amps		Dual Element Time Delay Fuse		Non-Time Delay Fuse		Circuit Breaker (3) Amps	Motor, Circuit Protector (4) Amps	140M Motor Starter with Adjustable Current Range (5) (6) Available Catalog Numbers (7)	Power Dissipation Watts			
	Frame	ND	HD	Amps	kVA	Cont.	1 Min.	3 Sec.	Min. (1)	Max. (2)							
480 Volt AC Input																	
20BD1P1	0	0.5	0.33	0.9	0.7	1.1	1.2	1.6	3	3	6	15	3	140M-C2E-B16	-	-	53
20BD2P1	0	1	0.75	1.6	1.4	2.1	2.4	3.2	3	3	8	15	3	140M-C2E-B25	-	-	63
20BD3P4	0	2	1.5	2.6	2.2	3.4	4.5	6.0	4	4	12	15	7	140M-C2E-B40	140M-D8E-B40	-	76
20BD5P0	0	3	2	3.9	3.2	5.0	5.5	7.5	6	10	6	20	7	140M-C2E-C63	140M-D8E-B63	-	93
20BD8P0	0	5	3	6.9	5.7	8.0	8.8	12	10	15	10	30	15	140M-C2E-C10	140M-F8E-C10	140M-F8E-C16	164
20BD011	0	7.5	5	9.5	7.9	11	12.1	16.5	15	20	15	40	15	140M-C2E-C16	140M-D8E-C16	140M-F8E-C16	194
20BD014	1	10	7.5	12.5	10.4	14	16.5	22	17.5	30	17.5	50	20	140M-C2E-C16	140M-D8E-C16	140M-F8E-C16	218
20BD022	1	15	10	19.9	16.6	22	24.2	33	25	50	80	80	30	140M-C2E-C25	140M-D8E-C25	140M-F8E-C25	326
20BD027	2	20	15	24.8	20.6	27	33	44	35	60	35	100	50	-	140M-F8E-C32	140M-F8E-C32	394
20BD034	2	25	20	31.2	25.9	34	40.5	54	40	70	40	125	50	-	140M-F8E-C45	140M-F8E-C45	441
20BD040	3	30	25	36.7	30.5	40	51	68	50	90	50	150	50	-	140M-F8E-C45	140M-F8E-C45	459
20BD052	3	40	30	47.7	39.7	52	60	80	60	110	60	200	70	-	-	140M-CMN-6300	610
20BD065	3	50	40	59.6	49.6	65	78	104	75	125	75	250	100	-	-	140M-CMN-9000	717
20BD077	4	-	50	59.6	49.6	65	98	130	100	170	100	300	100	-	-	140M-CMN-9000	717
20BD096	5	-	60	72.3	60.1	77	116	154	100	170	100	300	100	-	-	140M-CMN-9000	974
20BD125	5	-	75	90.1	74.9	96	144	188	125	200	125	350	125	-	-	140M-CMN-9000	974
20BD156	6	-	100	117	97.6	125	188	250	150	250	150	500	150	-	-	-	1146
20BD180	6	-	125	147	122	156	234	312	200	350	200	600	250	-	-	-	1475
			125	147	122	156	234	312	200	350	200	600	250	-	-	-	NA
			150	169	141	180	198	270	225	400	225	600	250	-	-	-	NA

Specifications

Power Ratings, Branch Circuit Protection and Power Dissipation, Cont'd

600 Volt AC Input Recommended Protection Devices (See Notes below)

Drive Catalog Number	Frame	HP Rating		PWM Freq. kHz	Temp. °C	Input Ratings			Output Amps			Dual Element Time Delay Fuse		Non-Time Delay Fuse		Circuit Breaker ⁽³⁾	Motor Circuit Protector ⁽⁴⁾	140M Motor Starter with Adjustable Current Range ^{(5) (6)}		
		ND	HD			Amps	kVA	Cont.	1 Min.	3 Sec.	Min. ⁽¹⁾	Max. ⁽²⁾	Min. ⁽¹⁾	Max. ⁽²⁾	Max. ⁽¹⁰⁾			Max. ⁽¹⁰⁾	Available Catalog Numbers - 140... ⁽⁷⁾	
600 Volt AC Input																				
20BE0P9	0	0.5	0.3	4	50	0.7	0.7	0.9	1.1	1.4	1	3	1	3	15	3	M-C2E-B10	-	-	-
20BE1P7	0	1	0.5	4	50	1.3	1.4	1.7	2	2.6	2	4	2	6	15	3	M-C2E-B16	-	-	-
20BE2P7	0	2	1	4	50	2.1	2.1	2.7	3.6	4.8	3	6	3	10	15	3	M-C2E-B25	-	-	-
20BE3P9	0	3	2	4	50	3.0	3.1	3.9	4.3	5.9	6	9	6	15	15	7	M-C2E-B40	M-D8E-B40	-	-
20BE6P1	0	5	3	4	50	5.3	5.5	6.1	6.7	9.2	9	12	9	20	20	15	M-C2E-B63	M-D8E-B63	-	-
20BE9P0	0	7.5	5	4	50	7.8	8.1	9	9.9	13.5	10	20	10	35	30	15	M-C2E-C10	M-D8E-C10	M-F8E-C10	
20BE011	1	10	7.5	4	50	9.9	10.2	11	13.5	18	15	25	15	40	40	15	M-C2E-C10	M-D8E-C10	M-F8E-C10	
20BE017	1	15	10	4	50	15.4	16.0	17	18.7	25.5	20	40	20	60	50	20	M-C2E-C16	M-D8E-C16	M-F8E-C16	
20BE022	2	20	15	4	50	20.2	21.0	22	25.5	34	30	50	30	80	80	30	M-C2E-C25	M-D8E-C25	M-F8E-C25	
20BE027	2	25	20	4	50	24.8	25.7	27	33	44	35	60	35	100	100	50	-	-	M-F8E-C25	
20BE032	3	30	25	4	50	29.4	30.5	32	40.5	54	40	70	40	125	125	50	-	-	M-F8E-C32	
20BE041	3	40	30	4	50	37.6	39.1	41	48	64	50	90	50	150	150	100	-	-	M-F8E-C45	
20BE052	3	50	40	4	50	47.7	49.6	52	61.5	82	60	110	60	200	200	100	-	-	-	
20BE062	4	60	50	2	50	58.2	60.5	62	78	104	80	125	80	225	225	100	-	-	-	
20BE077	5	75	-	2	50	72.3	75.1	77	85	116	90	150	90	300	300	100	-	-	-	
		-	60	2	50	58.2	60.5	63	94	126	90	125	90	250	250	100	-	-	-	
20BE099	5	100	-	2	40	92.9	96.6	99	109	126	125	200	125	375	375	150	-	-	-	
		-	75	2	40	72.3	75.1	77	116	138	100	175	100	300	300	100	-	-	-	
20BE125	6	125	-	2	50	117	122	125	-	-	150	250	150	375	375	250	-	-	-	
		-	100	2	50	92.9	96.6	99	-	-	125	200	125	375	375	150	-	-	-	
20BE144	6	150	-	2	50	135	141	144	-	-	175	300	175	400	400	250	-	-	-	
		-	125	2	50	117	122	125	-	-	150	275	150	375	375	250	-	-	-	

690 Volt AC Input Recommended Protection Devices (See Notes below)

Drive Catalog Number	Frame	kW Rating		PWM Freq. kHz	Temp. °C	Input Ratings			Output Amps			Dual Element Time Delay Fuse		Non-Time Delay Fuse		Circuit Breaker ⁽³⁾	Motor Circuit Protector ⁽⁴⁾	
		ND	HD			Amps	kVA	Cont.	1 Min.	3 Sec.	Min. ⁽¹⁾	Max. ⁽²⁾	Min. ⁽¹⁾	Max. ⁽²⁾	Max. ⁽¹⁰⁾			Max. ⁽¹⁰⁾
690 Volt AC Input																		
20BF052	5	45	-	4	50	46.9	56.1	52	57	78	60	110	60	175	175	-	-	
		-	37.5	4	50	40.1	48.0	46	69	92	50	90	50	150	150	-	-	
20BF060	5	55	-	4	50	57.7	68.9	60	66	90	80	125	80	225	225	-	-	
		-	45	4	50	46.9	56.1	52	78	104	60	110	60	175	175	-	-	
20BF082	5	75	-	2	50	79.0	94.4	82	90	123	100	200	100	375	375	-	-	
		-	55	2	50	57.7	68.9	60	90	120	80	125	80	225	225	-	-	
20BF098	5	90	-	2	40	94.7	113	98	108	127	125	200	125	375	375	-	-	
		-	75	2	40	79.0	94.4	82	123	140	100	200	100	375	375	-	-	
20BF119	6	110	-	2	50	115	137	119	131	179	150	250	150	400	-	-		
		-	90	2	50	94.7	113	98	147	196	125	200	125	375	-	-		
20BF142	6	132	-	2	50	138	165	142	156	213	175	300	175	450	-	-		
		-	110	2	50	115	137	119	179	238	150	250	150	400	-	-		

Notes:

- (1) Minimum protection device size is the lowest rated device that supplies maximum protection without nuisance tripping.
- (2) Maximum protection device size is the highest rated device that supplies drive protection. For US NEC, minimum size is 125% of motor FLA. Ratings shown are maximum.
- (3) Circuit Breaker - inverse time breaker. For US NEC, minimum size is 125% of motor FLA. Ratings shown are maximum.
- (4) Motor Circuit Protector - instantaneous trip circuit breaker. For US NEC minimum size is 125% of motor FLA. Ratings shown are maximum.
- (5) Bulletin 140M with adjustable current range should have the current trip set to the minimum range that the device will not trip.
- (6) Manual Self-Protected (Type E) Combination Motor Controller, UL listed for 208 Wye or Delta, 240 Wye or Delta, 480Y/277 or 600Y/ 347. Not UL listed for use on 480V or 600V Delta/Delta systems.
- (7) The AIC ratings of the Bulletin 140M Motor Protector may vary. See publication 140M-SG001B-EN-P.
- (8) 20BC085 current rating is limited to 45 ° C surrounding air.
- (9) 20BC205 current rating is limited to 40 ° C surrounding air.
- (10) Maximum allowable rating by US NEC. Exact size must be chosen for each installation.

Specifications

Power Ratings, Branch Circuit Protection and Power Dissipation, Cont'd

540 Volt DC Input Recommended Protection Devices

Drive Catalog Number	Frame	kW Rating		DC Input Ratings		Output Amps			Fuse	Bussmann Style Fuse
		ND	HD	Amps	kW	Cont.	1 Min.	3 Sec.		
540 Volt DC Input										
20BC1P3	1	0.37	0.25	1.3	0.7	1.3	1.4	1.9	3	BUSSMANN_JKS-3
20BC2P1	1	0.75	0.55	2.1	1.1	2.1	2.4	3.2	6	BUSSMANN_JKS-6
20BC3P5	1	1.5	0.75	3.7	2.0	3.5	4.5	6.0	8	BUSSMANN_JKS-8
20BC5P0	1	2.2	1.5	5.3	2.9	5.0	5.5	7.5	10	BUSSMANN_JKS-10
20BC8P7	1	4	3.0	9.3	5.0	8.7	9.9	13.2	20	BUSSMANN_JKS-20
20BC011	1	5.5	4	12.6	6.8	11.5	13	17.4	25	BUSSMANN_JKS-25
20BC015	1	7.5	5.5	16.8	9.1	15.4	17.2	23.1	30	BUSSMANN_JKS-30
20BC022	1	11	7.5	24	13	22	24.2	33	45	BUSSMANN_JKS-45
20BC030	2	15	11	33.2	17.9	30	33	45	60	BUSSMANN_JKS-60
20BC037	2	18.5	15	40.9	22.1	37	45	60	80	BUSSMANN_JKS-80
20BC043	3	22	18.5	47.5	25.7	43	56	74	90	BUSSMANN_JKS-90
20BC056	3	30	22	61.9	33.4	56	64	86	110	BUSSMANN_JKS-110
20BC072	3	37	30	80.5	43.5	72	84	112	150	BUSSMANN_JKS-150
20BC085	4	–	37	80.5	43.5	72	108	144	150	BUSSMANN_JKS-150
		45	–	95.1	51.3	85	94	128	200	BUSSMANN_JKS-200
20BH105 (1)	5	–	45	95.1	51.3	85	128	170	200	BUSSMANN_JKS-200
		55	–	117.4	63.4	105	116	158	200	BUSSMANN_JKS-200
20BH125 (1)	5	–	45	91.9	63.7	96	144	168	150	BUSSMANN_JKS-150
		55	–	139.8	75.5	125	138	163	225	BUSSMANN_JKS-225
20BH140 (1)	6	–	55	117.4	63.4	105	158	210	200	BUSSMANN_JKS-200
		75	–	158.4	85.6	140	154	210	300	BUSSMANN_JKS-300
20DH170 (1)	6	–	75	158.4	85.6	140	210	280	300	BUSSMANN_JKS-300
		90	–	192.4	103.9	170	187	255	350	BUSSMANN_JKS-350
20DH205 (1)	6	–	90	192.4	103.9	170	255	313	350	BUSSMANN_JKS-350
		110	–	232	125.3	205	220	289	400	BUSSMANN_JKS-400

(1) Also applies to "P" voltage class.

650 Volt DC Input Recommended Protection Devices

Drive Catalog Number	Frame	kW Rating		DC Input Ratings		Output Amps			Fuse	Bussmann Style Fuse
		ND	HD	Amps	kW	Cont.	1 Min.	3 Sec.		
650 Volt DC Input										
20BD1P1	0	0.5	0.33	1.0	0.6	1.1	1.2	1.6	6	BUSSMANN_JKS-6
20BD2P1	0	1	0.75	1.9	1.2	2.1	2.4	3.2	6	BUSSMANN_JKS-6
20BD3P4	0	2	1.5	3.0	2.0	3.4	4.5	6.0	6	BUSSMANN_JKS-6
20BD5P0	0	3	2	4.5	2.9	5.0	5.5	7.5	10	BUSSMANN_JKS-10
20BD8P0	0	5	3	8.1	5.2	8.0	8.8	12	15	BUSSMANN_JKS-15
20BD011	0	7.5	5	11.1	7.2	11	12.1	16.5	20	BUSSMANN_JKS-20
20BD014	1	10	7.5	14.7	9.5	14	16.5	22	30	BUSSMANN_JKS-30
20BD022	1	15	10	23.3	15.1	22	24.2	33	45	BUSSMANN_JKS-45
20BD027	2	20	15	28.9	18.8	27	33	44	60	BUSSMANN_JKS-60
20BD034	2	25	20	36.4	23.6	34	40.5	54	70	BUSSMANN_JKS-70
20BD040	3	30	25	42.9	27.8	40	51	68	80	BUSSMANN_JKS-80
20BD052	3	40	30	55.7	36.1	52	60	80	100	BUSSMANN_JKS-100
20BD065	3	50	40	69.7	45.4	65	78	104	150	BUSSMANN_JKS-150
20BR077 (1)	4	–	50	67.9	45.4	65	98	130	150	BUSSMANN_JKS-150
		60	–	84.5	54.7	77	85	116	150	BUSSMANN_JKS-150
20BR096 (1)	5	–	60	84.5	54.7	77	116	154	150	BUSSMANN_JKS-150
		75	–	105.3	68.3	96	106	144	200	BUSSMANN_JKS-200
20BR125 (1)	5	–	75	105.3	68.3	96	144	168	200	BUSSMANN_JKS-200
		100	–	137.1	88.9	125	138	163	250	BUSSMANN_JKS-250
20BR156 (1)	6	–	100	137.1	88.9	125	188	250	250	BUSSMANN_JKS-250
		125	–	171.2	110.9	156	172	234	300	BUSSMANN_JKS-300
20BR180 (1)	6	–	125	171.2	110.9	156	234	312	300	BUSSMANN_JKS-300
		150	–	204.1	132.2	180	198	270	400	BUSSMANN_JKS-400

(1) Also applies to "P" voltage class.

Specifications

Maximum Motor Cable Lengths (in feet)

480V HP Rating	Carrier Freq. (kHz)	1000 volt motor			1200 volt motor			1488 volt motor NEMA MG1-1998		
		Shielded (1)	Shielded (2)	Unshielded	Shielded (1)	Shielded (2)	Unshielded	Shielded (1)	Shielded (2)	Unshielded
0.5	4	50	25	75	50	220	320	220	420	NA
	8	40	20	75	40	220	220	220	420	NA
1	4	NA	NA	NA	NA	NA	NA	NA	NA	NA
	8	NA	NA	NA	NA	NA	NA	NA	NA	NA
2	4	NA	NA	NA	NA	NA	NA	NA	NA	NA
	8	NA	NA	NA	NA	NA	NA	NA	NA	NA
3	4	NA	NA	NA	NA	NA	NA	NA	NA	NA
	8	NA	NA	NA	NA	NA	NA	NA	NA	NA
5	4	25	25	75	40	420	520	420	620	NA
	8	25	25	75	40	420	275	420	520	NA
7.5	4	NA	NA	NA	NA	NA	NA	NA	NA	NA
	8	NA	NA	NA	NA	NA	NA	NA	NA	NA
10	4	NA	NA	NA	NA	NA	NA	NA	NA	NA
	8	NA	NA	NA	NA	NA	NA	NA	NA	NA
15	4	20	20	40	50	420	620	420	620	NA
	8	20	20	40	40	420	520	420	520	NA
25	4	20	20	40	50	620	620	620	620	NA
	8	20	20	40	40	620	420	620	620	NA

(1) Cable is Alcatel C1202 or equivalent. Shielded cable with twisted conductors and no filler.

(2) Cable is Belden 295xx series or equivalent.

Notes:

-1000V motor is defined as one assembled without phase paper. 1200V motor is defined as one assembled with phase paper. 1488V motor meets NEMA MG 1-1998 section 31 standard where the insulation can withstand voltage spikes of 3.1 x rated motor voltage due to inverter operation (inverter duty motor). 1600V motor is a 1329R or 1329L. Operation at nominal line voltage. To increase the distance between the drive and the motor, some mitigation device needs to be added to the system (i.e. an RWR or Terminator).

-NA = Data Not Available at time of publication.

Specifications

Mounting

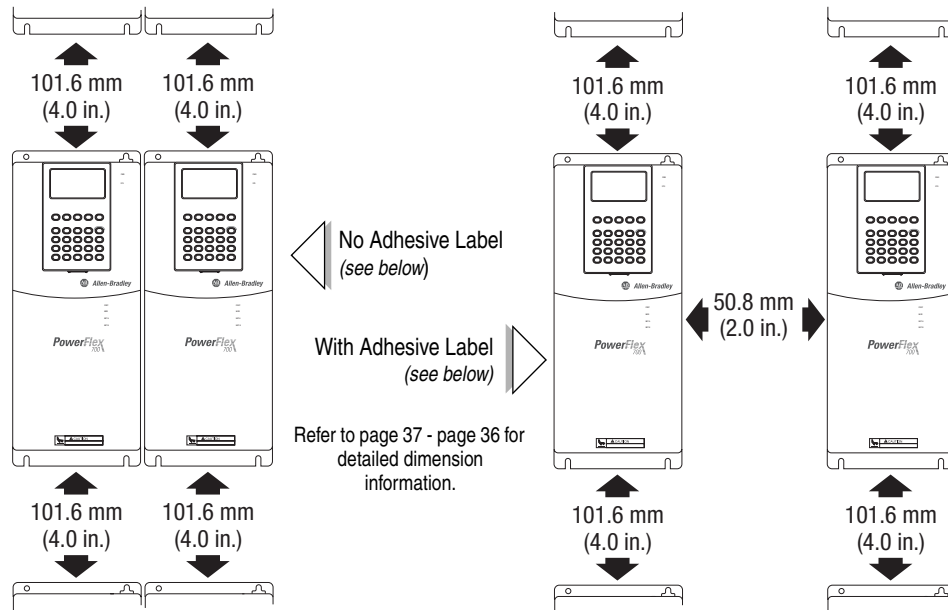

Operating Temperatures

PowerFlex 700 drives are designed to operate at 0° to 40° C surrounding air.
To operate the drive in installations between 41° and 50° C, refer to the table below.

Acceptable Surrounding Air Temperature & Required Actions

Drive Catalog Number	Required Action . . .		
	IP 20, NEMA Type 1	IP 20, NEMA Type Open	IP 00, NEMA Type Open
	No Action Required	Remove Top Label	Remove Top Label & Vent Plate
All <i>Except</i> 20BC072	40° C	50° C	NA
20BC072	40° C	45° C	50° C

Specifications

Approximate Dimensions

PowerFlex 700 Frames

Frame	AC Input								DC Input			
	208/240		400V		480V		600V		540V		650V	
	ND HP	HD HP	ND kW	HD kW	ND HP	HD HP	ND HP	HD HP	ND HP	HD HP	ND HP	HD HP
0	0.5	0.33	0.37	0.25	0.5	0.33	–	–	0.37	0.25	0.5	0.33
	1	0.75	0.75	0.55	1	0.75	–	–	0.75	0.55	1	0.75
	–	–	1.5	0.75	2	1.5	–	–	1.5	0.75	2	1.5
	–	–	2.2	1.5	3	2	–	–	2.2	1.5	3	2
	–	–	4	2.2	5	3	–	–	4	2.2	5	3
	–	–	5.5	4	7.5	5	–	–	5.5	4	7.5	5
1	2	1.5	7.5	5.5	10	7.5	10	7.5	7.5	5.5	10	7.5
	3	2	11	7.5	15	10	15	10	11	7.5	15	10
	5	3	–	–	–	–	–	–	–	–	–	–
	7.5	5	–	–	–	–	–	–	–	–	–	–
	–	–	–	–	–	–	–	–	–	–	–	–
2	10	7.5	15	11	20	15	20	15	15	11	20	15
	–	–	18.5	15	25	20	25	20	18.5	15	25	20
3	15	10	22	18.5	30	25	30	25	22	18.5	30	25
	20	15	30	22	40	30	40	30	30	22	40	30
	–	–	37	30	50	40	50	40	37	30	50	40
4	25	20	45	37	60	50	60	50	45	37	60	50
	30	25	–	–	–	–	–	–	–	–	–	–
5	40	30	55	45	75	60	75	60	55	45	75	60
	50	40	–	–	100	75	100	75	–	–	100	75
6	60	50	75	55	125	100	–	–	75	55	125	100
	75	60	90	75	150	125	–	–	90	75	150	125
	–	–	110	90	–	–	–	–	110	90	–	–

PowerFlex 700 Frames 0-3 (Frame 0 shown)

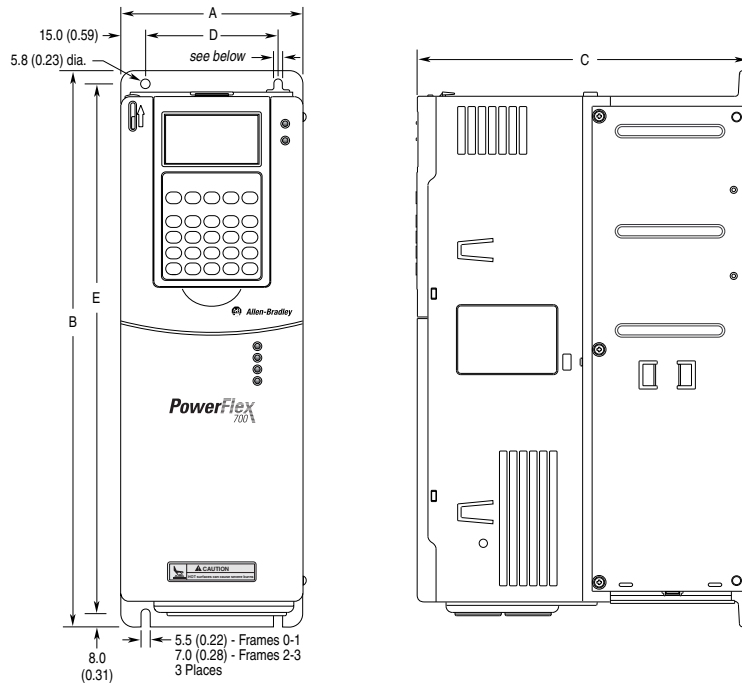

Dimensions are in millimeters and (inches). Weights are in kilograms and (pounds).

Frame	A	B	C	D	E	Weight (1) kg (lbs.)	
						Drive	Drive & Packaging
0	110.0 (4.33)	336.0 (13.23)	200.0 (7.87)	80.0 (3.15)	320.0 (12.60)	5.22 (11.5)	8.16 (18)
1	135.0 (5.31)	336.0 (13.23)	200.0 (7.87)	105.0 (4.13)	320.0 (12.60)	7.03 (15.5)	9.98 (22)
2	222.0 (8.74)	342.5 (13.48)	200.0 (7.87)	192.0 (7.56)	320.0 (12.60)	12.52 (27.6)	15.20 (33.5)
3	222.0 (8.74)	517.5 (20.37)	200.0 (7.87)	192.0 (7.56)	500.0 (19.69)	18.55 (40.9)	22.68 (50)

(1) Weights include HIM and Standard I/O.

Specifications

Approximate Dimensions, Cont'd

PowerFlex 700 Frame 4 Dimensions

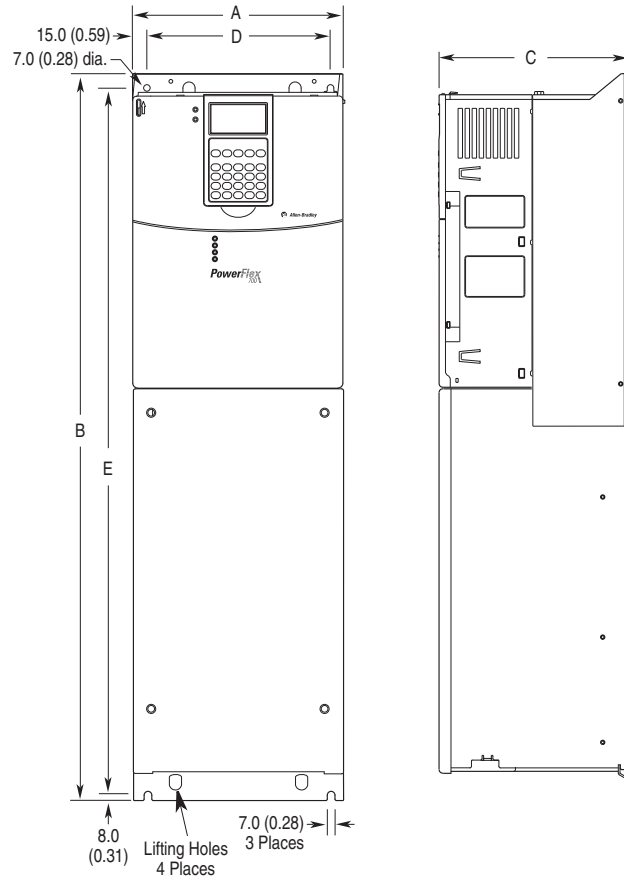

Frame	A (Max.)	B	C (Max.)	D	E	Approx. Weight (1) kg (lbs.)	
						Drive	Drive & Packaging
4	220.0 (8.66)	758.8 (29.87)	201.7 (7.94)	192.0 (7.56)	738.2 (29.06)	24.49 (54.0)	29.03 (64.0)

(1) Weights include HIM and Standard I/O.

Specifications

Approximate Dimensions, Cont'd

PowerFlex 700 Frame 5 Dimensions

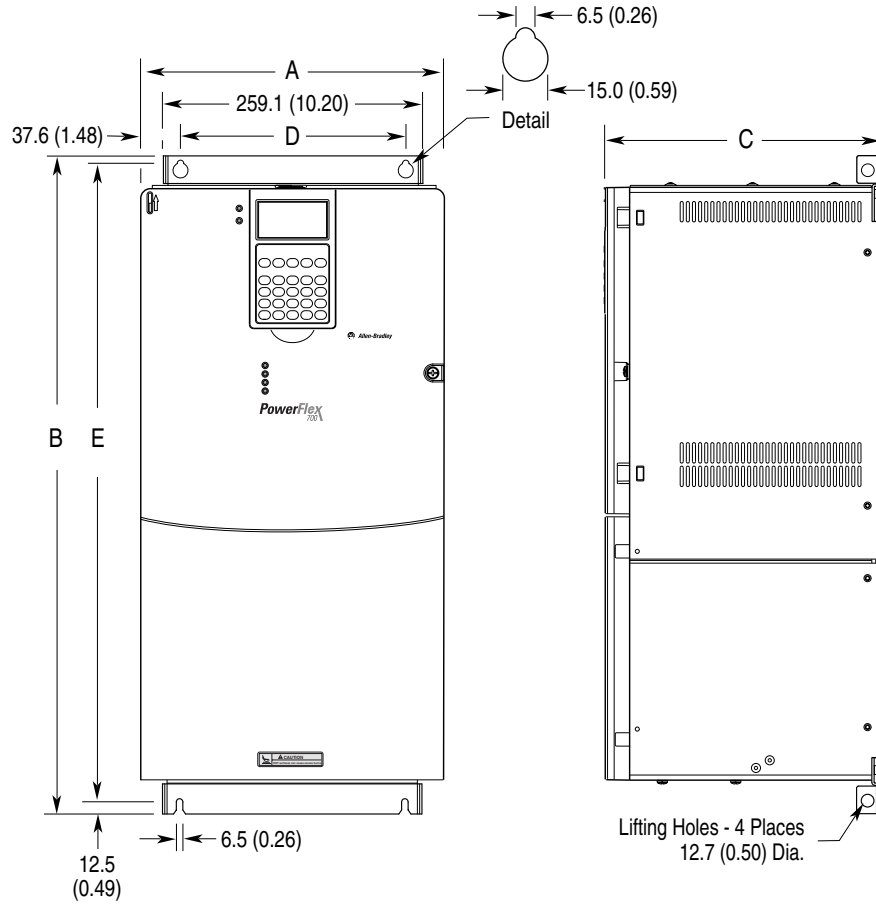

Frame	A (Max.)	B	C (Max.)	D	E	Approx. Weight (1) kg (lbs.)	
						Drive	Drive & Packaging
5	308 (12.16)	644.5 (25.37)	275.4 (10.84)	225.0 (24.61)	625.0 (24.61)	37.19 (82.0)	42.18 (93.0)

(1) Weights include HIM and Standard I/O.

Specifications

Approximate Dimensions, Cont'd

PowerFlex 700 Frame 6 Dimensions

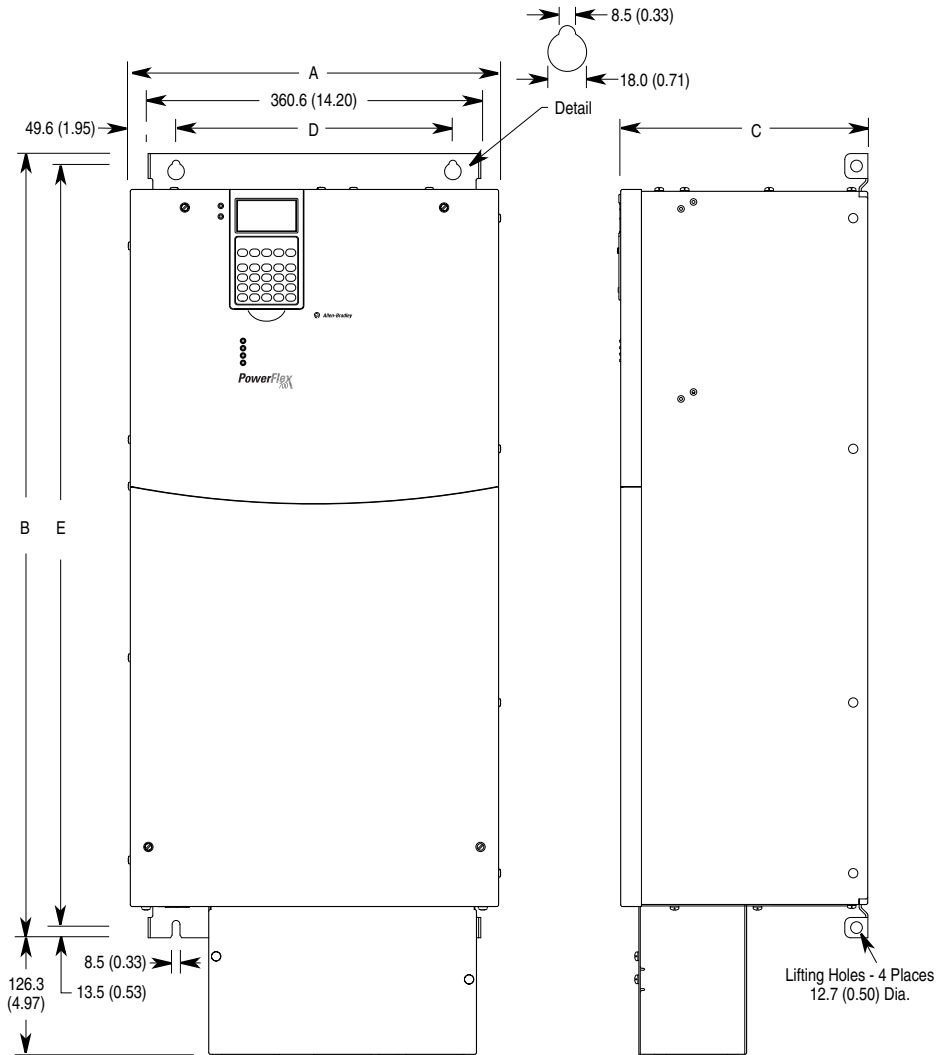

Frame	A (Max.)	B	C (Max.)	D	E	Approx. Weight (1) kg (lbs.)	
						Drive	Drive & Packaging
6	403.9 (15.90)	850.0 (33.46)	275.5 (10.85)	300.0 (11.81)	825.0 (32.48)	71.44 (157.5)	91.85 (202.5)

(1) Weights include HIM and Standard I/O.

Specifications

Approximate Dimensions, Cont'd

PowerFlex 700 Frames 0-3 Bottom View Dimensions

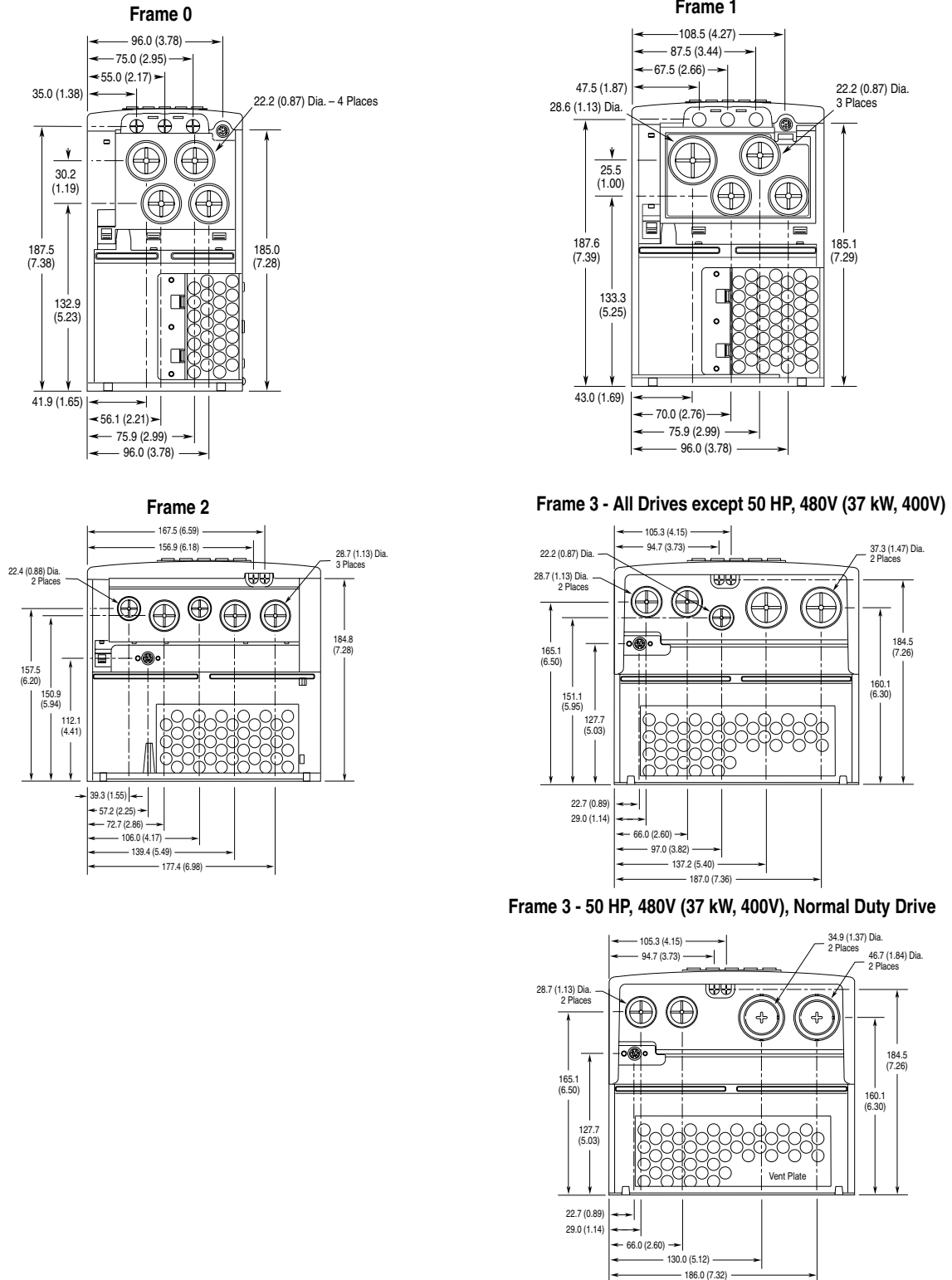

Specifications

Approximate Dimensions, Cont'd

PowerFlex 700 Frames 4-6 Bottom View Dimensions

Frame 4

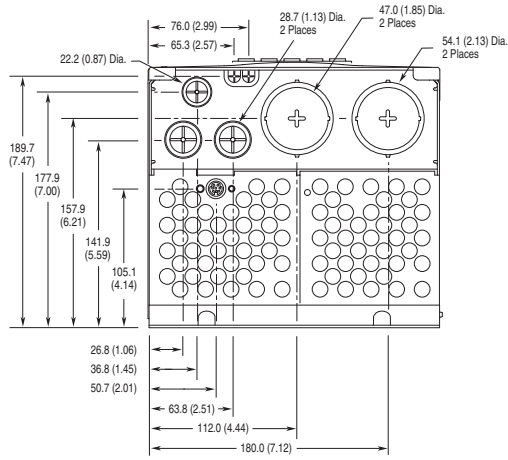

Frame 5 - 75 HP

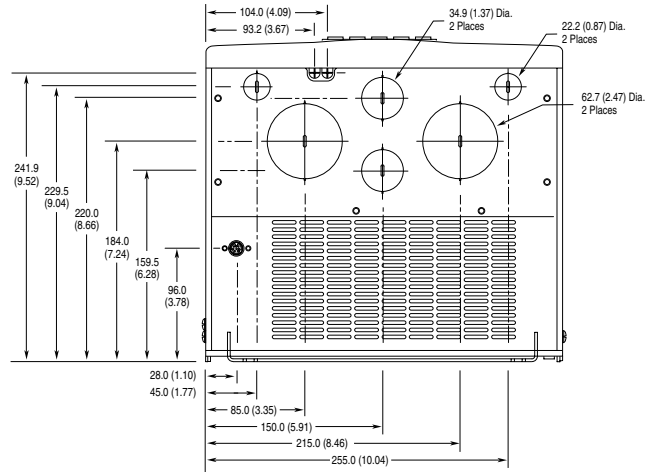

Frame 5 - 100 HP

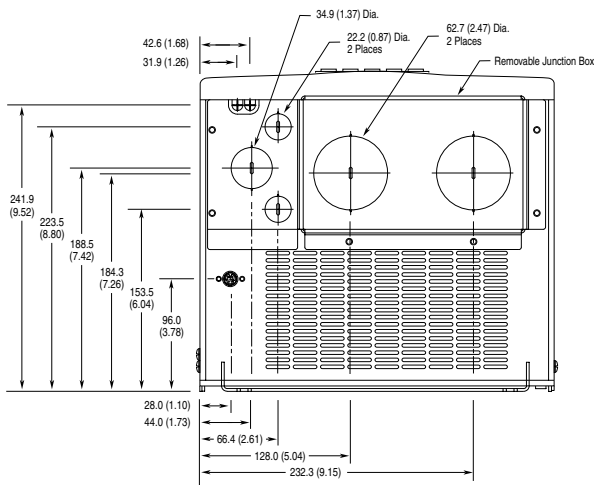

Frame 6

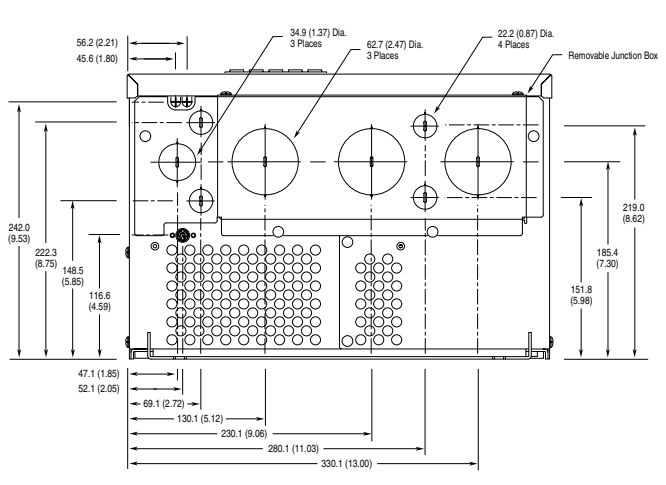

Specifications

Control and Performance

Category	Specification																																										
Protection	<table border="1"> <thead> <tr> <th>Drive</th> <th>200-208V</th> <th>240V</th> <th>380/400</th> <th>480V</th> <th>600V</th> <th>690V</th> </tr> </thead> <tbody> <tr> <td>AC Input Overvoltage Trip:</td> <td>247VAC</td> <td>285VAC</td> <td>475VAC</td> <td>570VAC</td> <td>690VAC</td> <td></td> </tr> <tr> <td>AC Input Undervoltage Trip:</td> <td>120VAC</td> <td>138VAC</td> <td>233VAC</td> <td>280VAC</td> <td>345VAC</td> <td></td> </tr> <tr> <td>Bus Overvoltage Trip:</td> <td>405VDC</td> <td>405VDC</td> <td>810VDC</td> <td>810VDC</td> <td>1013VDC</td> <td></td> </tr> <tr> <td>Bus Undervoltage Shutoff/Fault:</td> <td>153VDC</td> <td>153VDC</td> <td>305VDC</td> <td>305VDC</td> <td>381VDC</td> <td></td> </tr> <tr> <td>Nominal Bus Voltage:</td> <td>281VDC</td> <td>324VDC</td> <td>540VDC</td> <td>648VDC</td> <td>810VDC</td> <td></td> </tr> </tbody> </table>	Drive	200-208V	240V	380/400	480V	600V	690V	AC Input Overvoltage Trip:	247VAC	285VAC	475VAC	570VAC	690VAC		AC Input Undervoltage Trip:	120VAC	138VAC	233VAC	280VAC	345VAC		Bus Overvoltage Trip:	405VDC	405VDC	810VDC	810VDC	1013VDC		Bus Undervoltage Shutoff/Fault:	153VDC	153VDC	305VDC	305VDC	381VDC		Nominal Bus Voltage:	281VDC	324VDC	540VDC	648VDC	810VDC	
	Drive	200-208V	240V	380/400	480V	600V	690V																																				
	AC Input Overvoltage Trip:	247VAC	285VAC	475VAC	570VAC	690VAC																																					
	AC Input Undervoltage Trip:	120VAC	138VAC	233VAC	280VAC	345VAC																																					
	Bus Overvoltage Trip:	405VDC	405VDC	810VDC	810VDC	1013VDC																																					
	Bus Undervoltage Shutoff/Fault:	153VDC	153VDC	305VDC	305VDC	381VDC																																					
	Nominal Bus Voltage:	281VDC	324VDC	540VDC	648VDC	810VDC																																					
	All Drives																																										
	Heat Sink Thermistor:	Monitored by microprocessor overtemp trip																																									
	Drive Overcurrent Trip	200% of rated current (typical) 220-300% of rated current (dependent on drive rating)																																									
	Software Overcurrent Trip:																																										
	Hardware Overcurrent Trip:																																										
	Line transients:	up to 6000 volts peak per IEEE C62.41-1991																																									
	Control Logic Noise Immunity:	Showering arc transients up to 1500V peak																																									
Power Ride-Thru:	15 milliseconds at full load																																										
Logic Control Ride-Thru:	0.5 seconds minimum, 2 seconds typical																																										
Ground Fault Trip:	Phase-to-ground on drive output																																										
Short Circuit Trip:	Phase-to-phase on drive output																																										
Environment	Altitude:	1000 m (3300 ft) max. without derating																																									
	Maximum Surrounding Air Temperature without Derating:	0 to 50° C (32 to 122° F) 0 to 50° C (32 to 122° F) -40 to 70° C (-40 to 158° F)																																									
	IP20, NEMA Type 1:																																										
	IP56, NEMA Type 4X																																										
	Storage Temperature (all const.):																																										
	Atmosphere	Important: Drive must not be installed in an area where the surrounding air atmosphere contains volatile or corrosive gas, vapors or dust. If the drive is not going to be installed for a period of time, it must be stored in an area where it will not be exposed to a corrosive atmosphere.																																									
	Relative Humidity:	5 to 95% non-condensing																																									
	Shock:	15G peak for 11ms duration (±1.0 ms)																																									
Vibration:	0.152 mm (0.006 in.) displacement, 1G peak																																										
Agency Certification	The drive is designed to meet the following specifications: NFPA 70 - US National Electrical Code NEMA ICS 3.1 - Safety standards for Construction and Guide for Selection, Installation and Operation of Adjustable Speed Drive Systems. NEMA 250 - Enclosures for Electrical Equipment IEC 146 - International Electrical Code.																																										
		UL and cUL Listed to UL508C and CAN/CSA-C2.2 No. 14-M91																																									
		Marked for all applicable European Directives (1) EMC Directive (89/336/EEC) Emissions EN 61800-3 Adjustable Speed electrical power drive systems Part 3 Immunity EN 61800-3 Second Environment, Restricted Distribution Low Voltage Directive (73/23/EEC) EN 50178 Electronic Equipment for use in Power Installations																																									
Electrical	Voltage Tolerance:	See page 41 for Full Power and Operating Range.																																									
	Frequency Tolerance:	47-63 Hz.																																									
	Input Phases:	Three-phase input provides full rating for all drives. Single-phase operation provides 50% of rated current.																																									
	Displacement Power Factor	0.98 across speed range.																																									
	Efficiency:	97.5% at rated amps, nominal line volts.																																									
	Max. Short Circuit Current Rating: Using Recommended Fuse or Circuit Breaker Type	Maximum short circuit current rating to match specified fuse/circuit breaker capability.																																									

Specifications

Category	Specification		
Control	Method:	Sine coded PWM with programmable carrier frequency. Ratings apply to all drives. The drive can be supplied as 6 pulse or 12 pulse in a configured package.	
	Carrier Frequency	2, 4, 8 & 10 kHz. Drive rating based on 4 kHz	
	Output Voltage Range:	0 to rated motor voltage	
	Output Frequency Range:	Standard Control – 0 to 400 Hz., Vector Control – 0 to 420 Hz.	
	Frequency Accuracy Digital Input: Analog Input:	Within $\pm 0.01\%$ of set output frequency. Within $\pm 0.4\%$ of maximum output frequency.	
	Frequency Control	Speed regulation - with Slip Compensation (Volts per Hertz Mode) 0.5% of base speed across 40:1 speed range 40:1 operating range 10 rad/sec bandwidth	Standard Vector
		Speed regulation - with Slip Compensation (Sensorless Vector Mode) 0.5% of base speed across 80:1 speed range 80:1 operating range 20 rad/sec bandwidth	Standard Vector
		Speed regulation - with feedback (Sensorless Vector Mode) 0.1% of base speed across 80:1 speed range 80:1 operating range 20 rad/sec bandwidth	Vector
	Speed Control	Speed regulation - without feedback (Vector Control Mode) 0.1% of base speed across 120:1 speed range 120:1 operating range 50 rad/sec bandwidth	Vector
		Speed regulation - with feedback (Vector Control Mode) 0.001% of base speed across 120:1 speed range 1000:1 operating range 250 rad/sec bandwidth	Vector
	Torque Regulation	Torque Regulation - without feedback +/-10%, 600 rad/sec bandwidth	Vector
		Torque Regulation - with feedback +/-5%, 2500 rad/sec bandwidth	Vector
	Selectable Motor Control:	Sensorless Vector with full tuning. Standard V/Hz with full custom capability and vector control.	
	Stop Modes:	Multiple programmable stop modes including - Ramp, Coast, DC-Brake, Ramp-to-Hold and S-curve.	
	Accel/Decel:	Two independently programmable accel & decel times. Each time may be programmed from 0-3600 seconds in 0.1 sec. increments	
Intermittent Overload:	110% Overload capability for up to 1 minute 150% Overload capability for up to 3 seconds		
Current Limit Capability:	Proactive Current Limit programmable from 20 to 160% of rated output current. Independently programmable proportional and integral gain.		
Electronic Motor Overload Protection	Class 10 protection with speed sensitive response. Investigated by U.L. to comply with N.E.C. Article 430. U.L. File E59272, volume 12.		
Encoder	Type:	Incremental, dual channel	
	Supply:	12V, 500 mA. 12V, 10 mA minimum inputs isolated with differential transmitter, 250 kHz maximum.	
	Quadrature:	90° +/-27° at 25° C.	
	Duty Cycle:	50% +10%	
	Requirements:	Encoders must be line driver type, quadrature (dual channel) or pulse (single channel), 8-15V DC output, single-ended or differential and capable of supplying a minimum of 10 mA per channel. Maximum input frequency is 250 kHz. The Encoder Interface Board accepts 12V DC square-wave with a minimum high state voltage of 7.0V DC (12 volt encoder). Maximum low state voltage is 0.4V DC.	

(1) Applied noise impulses may be counted in addition to the standard pulse train causing erroneously high [Pulse Freq] readings.

Specifications

Voltage Tolerance

Drive Rating	Nominal Line Voltage	Nominal Motor Voltage	Drive Full Power Range	Drive Operating Range
200-240	200	200†	200-264	180-264
	208	208	208-264	
	240	230	230-264	
380-400	380	380†	380-528	342-528
	400	400	400-528	
	480	460	460-528	
500-600 (Frames 1-4 Only)	600	575†	575-660	432-660
500-690 (Frames 5 & 6 Only)	600	575†	575-660	475-759
	690	690	690-759	475-759

Drive Full Power Range = Nominal Motor Voltage to Drive Rated Voltage + 10%.
Rated current is available across the entire Drive Full Power Range

Drive Operating Range = Lowest† Nominal Motor Voltage - 10% to Drive Rated Voltage + 10%.
Drive Output is linearly derated when Actual Line Voltage is less than the Nominal Motor Voltage

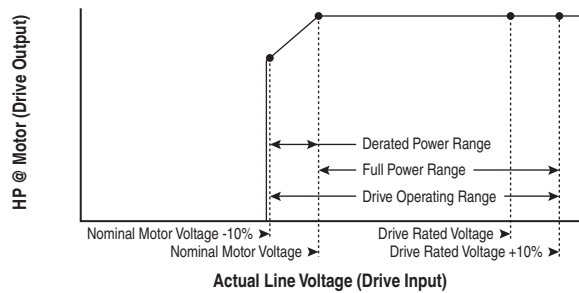

Example:

Calculate the maximum power of a 5 HP, 460V motor connected to a 480V rated drive supplied with 342V Actual Line Voltage input.

- Actual Line Voltage / Nominal Motor Voltage = 74.3%
- $74.3\% \times 5 \text{ HP} = 3.7 \text{ HP}$
- $74.3\% \times 60 \text{ Hz} = 44.6 \text{ Hz}$

At 342V Actual Line Voltage, the maximum power the 5 HP, 460V motor can produce is 3.7 HP at 44.6 Hz.

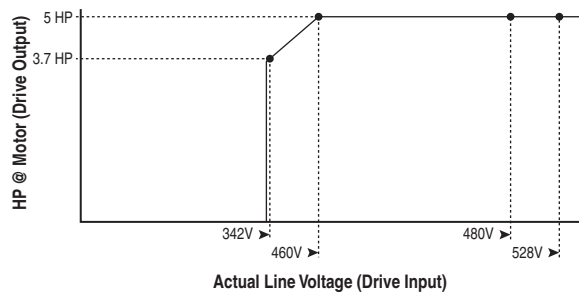

Parameters List

Shaded rows denote Vector parameters.

Parameter Name	Number	Group
Accel Mask	281	Masks & Owners
Accel Owner	293	Masks & Owners
Accel Time X	140-141	Ramp Rates
Alarm X @ Fault	229, 230	Diagnostics
Alarm X Code	262-269	Alarms
Alarm Clear	261	Alarms
Alarm Config 1	259	Alarms
Analog In X Hi	322, 325	Analog Inputs
Analog In X Lo	323, 326	Analog Inputs
Analog In X Loss	324, 327	Analog Inputs
Analog InX Value	16, 17	Metering
Analog OutX Hi	343, 346	Analog Outputs
Analog OutX Lo	344, 347	Analog Outputs
Analog OutX Sel	342, 345	Analog Outputs
Anlg In Config	320	Analog Inputs
Anlg In Sqr Root	321	Analog Inputs
Anlg Out Absolut	341	Analog Outputs
Anlg Out Config	340	Analog Outputs
Auto Rstrt Delay	175	Restart Modes
Auto Rstrt Tries	174	Restart Modes
Autotune	61	Torq Attributes
Autotune Torque	66	Torq Attributes
Break Frequency	72	Volts per Hertz
Break Voltage	71	Volts per Hertz
Bus Reg Kd	165	Stop/Brake Modes
Bus Reg Ki	160	Stop/Brake Modes
Bus Reg Kp	164	Stop/Brake Modes
Bus Reg Mode X	161, 162	Stop/Brake Modes
Commanded Freq	2	Metering
Commanded Speed	2	Metering
Commanded Torque	24	Metering
Compensation	56	Torq Attributes
Control Status	440	Torq Attributes
Control SW Ver	29	Drive Data
Current Lmt Gain	149	Load Limits
Current Lmt Sel	147	Load Limits
Current Lmt Val	148	Load Limits
Current Rate Limit	154	Load Limits
Data In XX	300-307	Datalinks
Data Out XX	310-317	Datalinks
DB Resistor Type	163	Stop/Brake Modes
DC Brake Level	158	Stop/Brake Modes
DC Brk Lvl Sel	157	Stop/Brake Modes
DC Brake Time	159	Stop/Brake Modes
DC Bus Memory	13	Metering
DC Bus Voltage	12	Metering
Decel Mask	282	Masks & Owners
Decel Owner	294	Masks & Owners
Decel Time X	142, 143	Ramp Rates
Dig In Status	216	Diagnostics
Dig Out Status	217	Diagnostics
Dig OutX Level	381, 385, 389	Digital Outputs
Dig OutX OffTime	383, 387, 391	Digital Outputs
Dig OutX OnTime	382, 386, 390	Digital Outputs
Digital InX Sel	361-366	Digital Inputs
Digital OutX Sel	380, 384, 388	Digital Outputs
Direction Mask	279	Masks & Owners
Direction Mode	190	Direction Config
Direction Owner	291	Masks & Owners
DPI Baud Rate	270	Comm Control
DPI Data Rate	270	Comm Control

Parameter Name	Number	Group
DPI Port Sel	274	Comm Control
DPI Port Value	275	Comm Control
Drive Alarm X	211-212	Diagnostics
Drive Checksum	203	Drive Memory
Drive Logic Rslt	271	Comm Control
Drive OL Count	219	Diagnostics
Drive OL Mode	150	Load Limits
Drive Ramp Rslt	273	Comm Control
Drive Ref Rslt	272	Comm Control
Drive Status X	209, 210	Diagnostics
Drive Temp	218	Diagnostics
Droop RPM @ FLA	152	Load Limits
Elapsed MWh	9	Metering
Elapsed Run Time	10	Metering
Enc Position Fdbk	414	Speed Feedback
Encoder PPR	413	Speed Feedback
Encoder Speed	415	Speed Feedback
Encoder Z Chan	423	Speed Feedback
Fault 1 Code	243	Faults
Fault 1 Time	244	Faults
Fault 2 Code	245	Faults
Fault 2 Time	246	Faults
Fault 3 Code	247	Faults
Fault 3 Time	248	Faults
Fault 4 Code	249	Faults
Fault 4 Time	250	Faults
Fault 5 Code	251	Faults
Fault 5 Time	252	Faults
Fault 6 Code	253	Faults
Fault 6 Time	254	Faults
Fault 7 Code	255	Faults
Fault 7 Time	256	Faults
Fault 8 Code	257	Faults
Fault 8 Time	258	Faults
Fault Amps	225	Diagnostics
Fault Bus Volts	226	Diagnostics
Fault Clear	240	Faults
Fault Clear Mode	241	Faults
Fault Ctr Mask	283	Masks & Owners
Fault Ctr Owner	295	Masks & Owners
Fault Config 1	238	Faults
Fault Frequency	224	Diagnostics
Fault Speed	224	Diagnostics
Fdbk Filter Sel	416	Speed Feedback
Feedback Select	80	Spd Mode & Limits
Flux Braking	166	Stop/Brake Modes
Flux Current	5	Metering
Flux Current Ref	63	Torq Attributes
Flux Up Mode	57	Torq Attributes
Flux Up Time	58	Torq Attributes
Flying Start En	169	Restart Modes
Flying StartGain	170	Restart Modes
Inertia Autotune	67	Torq Attributes
IR Voltage Drop	62	Torq Attributes
Ixo Voltage Drop	64	Torq Attributes
Jog Mask	278	Masks & Owners
Jog Owner	290	Masks & Owners
Jog Speed/1	100	Discrete Speeds
Jog Speed 2	108	Discrete Speeds
Kf Speed Loop	447	Speed Regulator
Ki Speed Loop	445	Speed Regulator
Kp Speed Loop	446	Speed Regulator
Language	201	Drive Memory
Last Stop Source	215	Diagnostics
Load Frm Usr Set	198	Drive Memory

Parameter Name	Number	Group
Local Mask	285	Masks & Owners
Local Owner	297	Masks & Owners
Logic Mask	276	Masks & Owners
Man Ref Preload	193	HIM Ref Config
Marker Pulse	421	Speed Feedback
Maximum Freq	55	Torq Attributes
Maximum Speed	82	Spd Mode & Limits
Maximum Voltage	54	Torq Attributes
Minimum Speed	81	Spd Mode & Limits
MOP Frequency	11	Metering
MOP Mask	284	Masks & Owners
MOP Owner	296	Masks & Owners
MOP Rate	195	MOP Config
MOP Reference	11	Metering
Motor Cntl Sel	53	Torq Attributes
Motor Fdbk Type	412	Speed Feedback
Motor NP FLA	42	Motor Data
Motor NP Hertz	43	Motor Data
Motor NP Power	45	Motor Data
Motor NP RPM	44	Motor Data
Motor NP Volts	41	Motor Data
Motor OL Count	220	Diagnostics
Motor OL Factor	48	Motor Data
Motor OL Hertz	47	Motor Data
Motor Poles	49	Motor Data
Motor Type	40	Motor Data
Mtr NP Pwr Units	46	Motor Data
Mtr Tor Cur Ref	441	Torq Attributes
Neg Torque Limit	437	Torq Attributes
Notch Filter Freq	419	Speed Feedback
Notch Filter K	420	Speed Feedback
Output Current	3	Metering
Output Freq	1	Metering
Output Power	7	Metering
Output Powr Fctr	8	Metering
Output Voltage	6	Metering
Overspeed Limit	83	Spd Mode & Limits
Param Access Lvl	196	Drive Memory
PI Configuration	124	Process PI
PI Control	125	Process PI
PI Error Meter	137	Process PI
PI Fdbk Meter	136	Process PI
PI Feedback Hi	462	Process PI
PI Feedback Lo	463	Process PI
PI Feedback Sel	128	Process PI
PI Integral Time	129	Process PI
PI Lower Limit	131	Process PI
PI Output Meter	138	Process PI
PI Preload	133	Process PI
PI Prop Gain	130	Process PI
PI Ref Meter	135	Process PI
PI Reference Hi	460	Process PI
PI Reference Lo	461	Process PI
PI Reference Sel	126	Process PI
PI Setpoint	127	Process PI
PI Status	134	Process PI
PI Upper Limit	132	Process PI
Pos Torque Limit	436	Torq Attributes
Power Loss Level	186	Power Loss
Power Loss Mode	184	Power Loss
Power Loss Time	185	Power Loss
Powerup Delay	167	Restart Modes
Power Up Marker	242	Faults
Preset Speed X	101-107	Discrete Speeds

Parameter List, Cont'd

Parameter Name	Number	Group
Pulse Input Ref	99	Speed Reference
Pulse In Scale	422	Speed Feedback
PWM Frequency	151	Load Limits
Ramped Speed	22	Metering
Rated Amps	28	Drive Data
Rated kW	26	Drive Data
Rated Volts	27	Drive Data
Reference Mask	280	Masks & Owners
Reference Owner	292	Masks & Owners
Regen Power Limit	153	Load Limits
Reset Meters	200	Drive Memory
Reset To Defaults	197	Drive Memory
Rev Speed Limit	454	Speed Regulator
Run Boost	70	Volts per Hertz
S Curve %	146	Ramp Rates
Save HIM Ref	192	HIM Ref Config
Save MOP Ref	194	MOP Config
Save To User Set	199	Drive Memory
ScaleX In Value	476, 482	Scaled Blocks
ScaleX In Hi	477, 483	Scaled Blocks
ScaleX In Lo	478, 484	Scaled Blocks
ScaleX Out Hi	479, 485	Scaled Blocks
ScaleX Out Lo	480, 486	Scaled Blocks
ScaleX Out Value	481, 487	Scaled Blocks
Skip Freq Band	87	Spd Mode & Limits
Skip Frequency X	84-86	Spd Mode & Limits
Sleep Level	182	Restart Modes
Sleep Time	183	Restart Modes
Sleep-Wake Mode	178	Restart Modes
Sleep-Wake Ref	179	Restart Modes
Slip Comp Gain	122	Slip Comp
Slip RPM @ FLA	121	Slip Comp
Slip RPM Meter	123	Slip Comp
Speed Desired BW	449	Speed Regulator
Speed Feedback	25	Metering
Speed Mode	80	Spd Mode & Limits
Speed Ref X Hi	91, 94	Speed Reference
Speed Ref X Lo	92, 95	Speed Reference
Speed Ref X Sel	90, 93	Speed Reference
Speed Ref Source	213	Diagnostics
Speed Reference	23	Metering
Speed Units	79	Spd Mode & Limits
Speed/Torque Mod	88	Spd Mode & Limits
Start At PowerUp	168	Restart Modes
Start Inhibits	214	Diagnostics
Start Mask	277	Masks & Owners
Start Owner	289	Masks & Owners
Start/Acc Boost	69	Volts per Hertz
Status X @ Fault	227, 228	Diagnostics
Stop Mode A	155	Stop/Brake Modes
Stop Mode B	156	Stop/Brake Modes
Stop Owner	288	Masks & Owners
Stop/BRK Mode A	155	Stop/Brake Modes
Stop/BRK Mode B	156	Stop/Brake Modes
SV Boost Filter	59	Torq Attributes
TB Man Ref Hi	97	Speed Reference
TB Man Ref Lo	98	Speed Reference
TB Man Ref Sel	96	Speed Reference
Testpoint X Data	235, 237	Diagnostics
Testpoint X Sel	234, 236	Diagnostics
Torq Ref A Div	430	Torq Attributes
Torque Current	4	Metering

Parameter Name	Number	Group
Torque Perf Mode	53	Torq Attributes
Torque Ref X Sel	427, 431	Torq Attributes
Torque Ref X Hi	428, 432	Torq Attributes
Torque Ref X Lo	429, 433	Torq Attributes
Torque Setpoint	435	Torq Attributes
Torque Ref B Mult	434	Torq Attributes
Total Inertia	450	Spd Regulator
Trim Hi	119	Speed Trim
Trim In Select	117	Speed Trim
Trim Lo	120	Speed Trim
Trim Out Select	118	Speed Trim
Voltage Class	202	Drive Memory
Wake Level	180	Restart Modes
Wake Time	181	Restart Modes

PowerFlex is a registered trademark of Rockwell Automation.
Zero Stacking, Force Technology, DriveExplorer, DriveTools SP, DPI and PanelView are trademarks of Rockwell Automation.
ControlNet is a trademark of ControlNet International, Ltd.
DeviceNet is a trademark of the Open DeviceNet Vendor Association.

www.rockwellautomation.com

Corporate Headquarters

Rockwell Automation, 777 East Wisconsin Avenue, Suite 1400, Milwaukee, WI, 53202-5302 USA, Tel: (1) 414.212.5200, Fax: (1) 414.212.5201

Headquarters for Allen-Bradley Products, Rockwell Software Products and Global Manufacturing Solutions

Americas: Rockwell Automation, 1201 South Second Street, Milwaukee, WI 53204-2496 USA, Tel: (1) 414.382.2000, Fax: (1) 414.382.4444
Europe/Middle East/Africa: Rockwell Automation SA/NV, Vorstlaan/Boulevard du Souverain 36, 1170 Brussels, Belgium, Tel: (32) 2 663 0600, Fax: (32) 2 663 0640
Asia Pacific: Rockwell Automation, 27/F Citicorp Centre, 18 Whitfield Road, Causeway Bay, Hong Kong, Tel: (852) 2887 4788, Fax: (852) 2508 1846

Headquarters for Dodge and Reliance Electric Products

Americas: Rockwell Automation, 6040 Ponders Court, Greenville, SC 29615-4617 USA, Tel: (1) 864.297.4800, Fax: (1) 864.281.2433
Europe/Middle East/Africa: Rockwell Automation, Brühlstraße 22, D-74834 Elztal-Dallau, Germany, Tel: (49) 6261 9410, Fax: (49) 6261 17741
Asia Pacific: Rockwell Automation, 55 Newton Road, #11-01/02 Revenue House, Singapore 307987, Tel: (65) 6356-9077, Fax: (65) 6356-9011

U.S. Allen-Bradley Drives Technical Support

Tel: (1) 262.512.8176, Fax: (1) 262.512.2222, Email: support@drives.ra.rockwell.com, Online: www.ab.com/support/abdrives