

RCB600, MCB600 User Manual

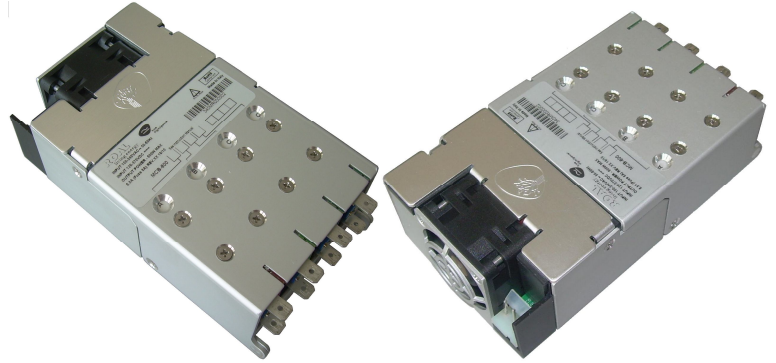

The RCB and MCB series user manual has been prepared by the Roal Electronics design team to assist qualified engineers in correctly implementing the products and to achieve the best reliability and performance.

At time of print, the information contained in this document is believed to be correct and accurate. However, specifications are subject to change without prior notice and Roal Electronics will not be liable for any damage caused as a result of the information within this document. For continued product improvement, please report any errors contained in the document to Roal Electronics SpA.

RCB600 AND MCB600 SERIES OVERVIEW

The RCB600 and MCB600 switch mode power supply series offers truly unrivalled power density, providing 600 W at 25 W/in³ in a 5" x 3"x 1U package. They are the ultimate power solutions for system designers as they address the pressing demands for more power within less space. Providing multiple isolated outputs, the series carry full UL60601 (MCB600) and UL60950 2nd edition (RCB600) safety approvals.

The basic system consists of an input module together with up to four fully isolated output modules, all supplied with advanced remote voltage and current programming functionality as standard.

The input module delivers up to 600 W of output power and has 4 slots, each capable of separately delivering up to 150 W. A 5 V, 200 mA medically isolated bias supply together with an AC mains signal (AC_OK) and a global inhibit signal (GINH) that can disable all outputs simultaneously, comes as standard on all models.

A built in fan, which speed is automatically controlled, ensures the unit proper cooling in any operating condition maintaining at minimum fan RPM and, in turn, acoustic noise.

Output modules are currently available in single output types with models covering voltage ranges from 1.5 V to 58 V and currents up to 25 A. All outputs can be connected in parallel or in a series resulting in a voltage range of up to 232 V and a maximum current of up to 100 A from a single chassis.

By selecting the correct output modules, a custom power solution can be configured in a few minutes. This instantly available custom solution offers industry leading power density, total system efficiencies of up to 89% and suits all types of applications including industrial, medical, aerospace, military and telecoms.

CONTENTS

RCB600 and MCB600 series overview	1
Models and ordering information.....	3
Installation Notes	4
Theory of operation	5
Input module operation.....	6
Signalling	9
Output module operation.....	11
Advanced output module features.....	14
Seriesed outputs	17
Outputs in parallel configuration.....	18
Mechanical dimensions and mounting.....	22
Connectors	23
Configuring your power supply	24
Safety	29
EMC compliance.....	27
Reliability	31

CONFIGURATIONS AND ORDERING INFORMATION

The RCB/MCB600 part numbering system is easily comprehensible following the scheme in the table below.

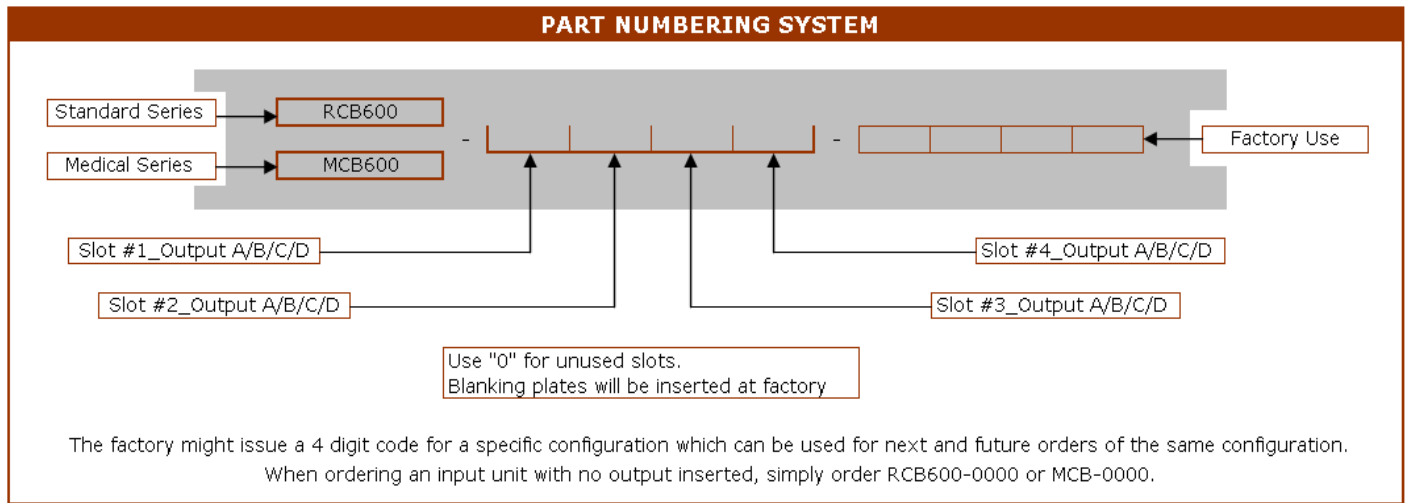

A power unit part number can also be easily accessed through the descriptive label placed on its top surface (see picture below). Simply add to the unit part number the letters visible through the lid holes following the order indicated by the lines. Each letter identifies the selected output module fitted in the correspondent slot.



Part Number: **MCB600-ABCC**

The following table contains all the characteristic parameter of each Output Module, OP-x, and is a useful guide in identifying the optimal configuration for every application.

Output Module	Nominal Voltage	Rated current	Voltage Adjustment	Load Regulation	Line Regulation	OVP	Output Power
A	5 V	25.0 A	1.5 to 7.5 V	±50 mV	±0.1 %V _{NOM}	9.5 V	125 W
B	12 V	15 A	4.5 to 15 V	±100 mV	±0.1 %V _{NOM}	18 V	150 W
C	24 V	7.5 A	9 to 30 V	±150 mV	±0.1 %V _{NOM}	36 V	150 W
D	48 V	3.75 A	18 to 58 V	±300 mV	±0.1 %V _{NOM}	66 V	150 W
0 (zero)				Unused slots			

Example: For an MCB600 with 5 V at 25 A (Module A in slot 1), 12 V at 12.5 A (Module B in slot 2) and 24 V at 12.5 A (Module C x 2 in slot 3 and slot 4), use **"MCB600-ABCC"**.

INSTALLATION NOTES

This power supply is intended for use within equipment or enclosures which restricts access to authorised personnel only. The instructions in this manual and all warning labels on the product must be followed carefully.

Safety

All power supplies must be installed correctly in a controlled environment which restricts access to any unauthorised personnel. Equipment and system manufacturers must protect service personnel against unintentional contact with the output terminals.

Hazards

If series and/or parallel combinations of outputs exceed safe voltage and/or energy levels, the final equipment manufacturer must provide appropriate protection for both users and service personnel.

Health and safety

To comply with section 6 of the health and safety at work act, a label that is clearly visible to service personnel must be placed on the final equipment, which warns that surfaces of the power supply may be hot and should not be touched when the product is operating.

Fusing

The power supply has internal single pole fusing in the L (Live) line.

Servicing

The power supply contains no user serviceable parts. Repairs must be carried out by authorized personnel only. Contact Roal Electronics SpA for further information.

Cooling

For proper cooling of the power supply, the air intake and outlet must not be impeded. Allow 50 mm clearance at both ends and position cabling appropriately. Avoid excessive back pressure in the general system or when using ducting to navigate hot air out of the system.

Earth terminal marking

To comply with the requirements of UL60950-1, EN60950-1, IEC60950-1, CSA22.2 no. 60950-1, UL60601-1, EN60601-1, IEC60601-1, CSA22.2 no 601-1, where the incoming wiring earth is intended for connection as the main protective earthing conductor and where the terminals for such a connection is not supplied on a component or subassembly such as a terminal block, the user shall add an appropriate label displaying a protective earth symbol in accordance with 60417-2-IEC-5019 directly adjacent to the terminal. The label should be durable and legible and should withstand the 15s rub test as per UL60950-1 section 1.7.15.

Mounting

Mounting the unit can be done using the bottom or side mounting points. Each mounting point accepts an M4 screw where the maximum penetration, inclusive of 1.75 mm chassis thickness, should never exceed 4.00 mm. The maximum torque for the M4 screws is 1.50 Nm.

Other

- To prolong the life of the unit, use in dust free environment.
- If units are damaged during transit, contact your sales agent or Roal Electronics and DO NOT apply power to the unit.
- Always use adequately sized cables and ensure good crimp connections.
- Use cable supports to minimise stress on connectors.
- Avoid excessive shock or vibration.

General installation parameters

- | | | | |
|-------------------------|------------------------|-----------------------|------------|
| • Equipment class | I | • Flammability rating | 94V-2 |
| • Installation category | II | • IP rating | IP10 |
| • Pollution degree | 2 | • RoHS compliance | 2002/95/EC |
| • Material group | IIIb (Indoor use only) | | |

THEORY OF OPERATION

The diagram below outlines the topology and major internal components of a fully assembled system. Four output slots are provided and can be populated by any combination of *output modules* (OP-A, OP-B, OP-C, OP-D). The remaining components in the block diagram are housed in the *input module*.

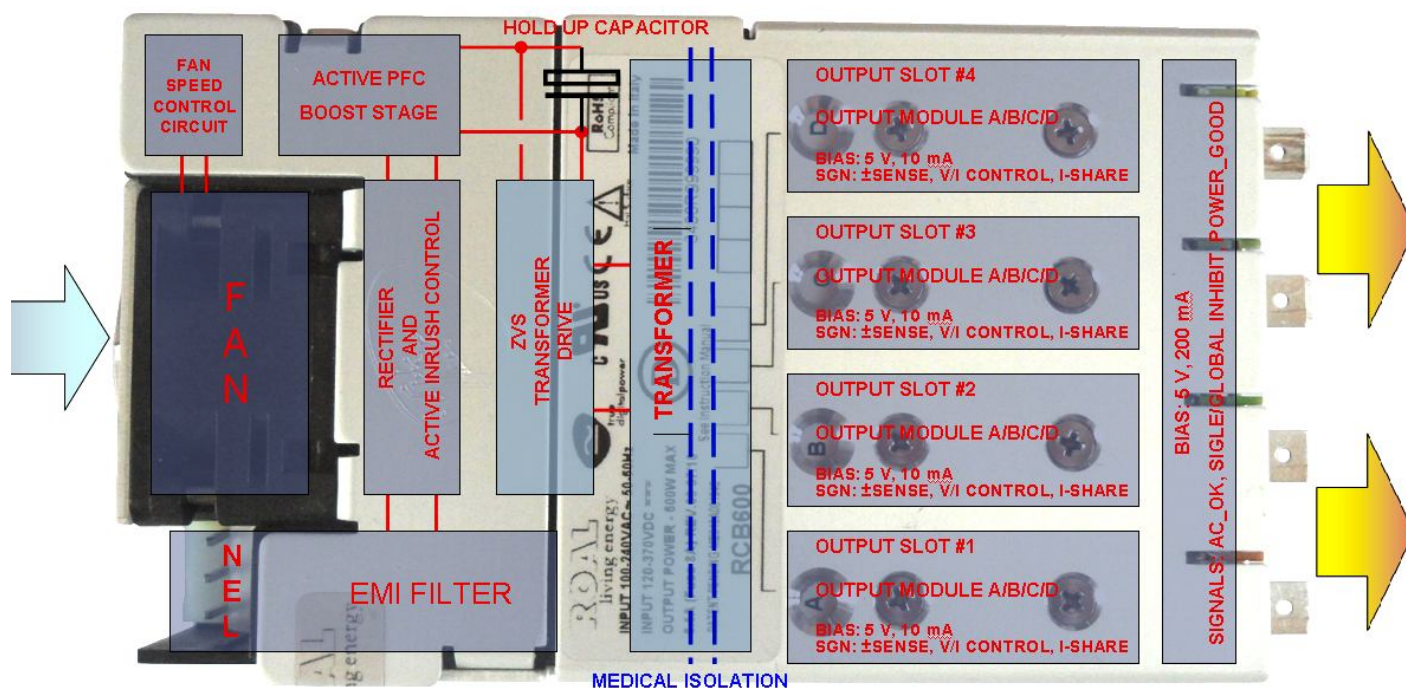

The *input module* is responsible for receiving the AC mains line voltage and converting it to an appropriate DC voltage whilst providing protection from AC line disturbances and preventing excessive EMI emissions and current harmonics. The integrated EMI filter attenuates high frequency current emissions to levels below EN55022 class B. It also provides single pole fusing in the live conductor (L) and protection from line disturbances as outlined in EN61000.

Inrush current is controlled by a resistive element upon initial connection to the AC line. Once the internal capacitances have been charged, the resistive element is bypassed to reduce losses.

Active Power Factor Correction (PFC) is used to ensure an accurate input current waveform with extremely low harmonic content, exceeding the requirements of EN61000-3-2. This stage also provides active input current limiting which prevents overloading of the input stage while maintaining high power factor.

The output of the PFC stage charges the hold-up electrolytic capacitors which store enough energy to allow the system to continue operating during minor line disturbances. These are the only electrolytic capacitors in the entire power supply and to further increase system reliability, long life and high temperature capacitors are used.

A highly efficient zero voltage switching circuit (ZVS) is used to drive the medically isolated transformer from the hold-up capacitors. The output modules connect to the transformer secondary and provide safe isolated power to a high performance synchronous rectifier power converter which is controlled using the latest analog control technology to produce superior output performance in an extremely reduced size.

A built in fan, which speed is automatically controlled, ensures the unit proper cooling in any operating condition maintaining at minimum its RPM and, in turn, acoustic noise. The control function directly correlate the fan supply voltage to the control voltage derived from the half bridge current sense resistor. The secondary control input is derived from a non-linear temperature sensor located near the rectifiers on the main board.

INPUT MODULE OPERATION

Start-up and shut-down

The RCB600 and MCB600 input modules operate from a universal input voltage range and start automatically upon application of adequate AC mains voltage ($>84 V_{RMS}$). After a short delay, the global "+5V bias" supply starts and the "ACOK" signal goes high to indicate that the mains voltage is present and input stage is operating correctly. Once the "ACOK" signal is high, the output modules turn on and deliver power to the application loads. The "Power Good" signals will indicate that the output voltages are within specification. The diagram below shows the normal start-up/shut-down sequence and gives typical timings.

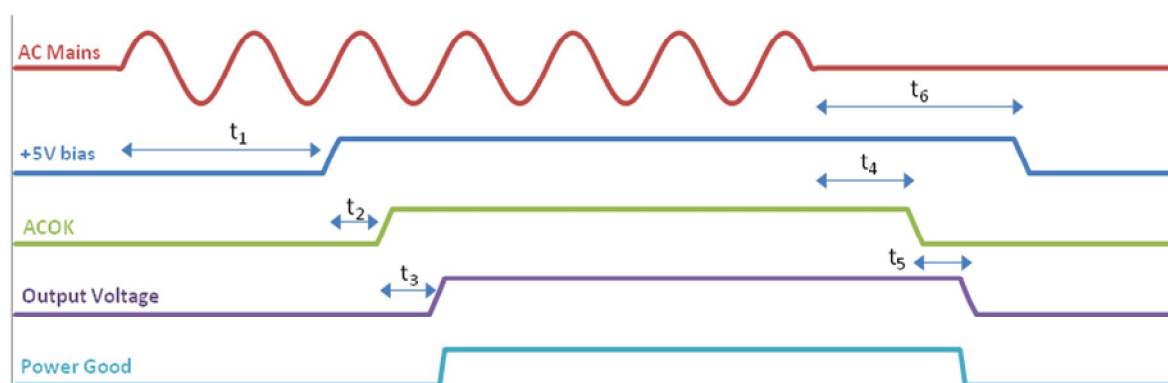

Typical timing values: $t_1 = 300 \text{ ms}$, $t_2 = 50 \text{ ms}$, $t_3 = 25 \text{ ms}$, $t_4 = 15 \text{ ms}$, $t_5 = 5 \text{ ms}$ (minimum), $t_6 = 100 \text{ ms}$

When the AC mains voltage is removed, the internal hold-up capacitors will supply power to the load for typically 20 ms (t_4+t_5) at maximum power. The "ACOK" signal will go low at least 5 ms before the output voltages fall below the power good threshold level. This allows the application to prepare for the impending loss of power. The "+5V bias" supply will remain on for typically 100 ms, after the output modules have turned off.

Hold-up

For short line disturbances ($<20 \text{ ms}$), the output voltages will not be affected*. However, the "ACOK" signal may still go low to warn that there is an impending loss of output power. The "ACOK" signal will return to the high state once the unit has recovered from the disturbance.

*Outputs that are adjusted above the hold-up voltage as detailed in their respective datasheets, may experience a dip in voltage but never below the hold-up voltage specified.

Idle power

The idle power of the RCB/MCB PSU is extremely low when compared to similar power supplies.

With the output modules enabled the unit typically only requires 28 W with no output load. To reduce the idle power further the outputs can be disabled using the global inhibit (GINH) pin. With the outputs disabled the unit typically requires less than 21 W.

Over temperature protection (OTP)

The input module is protected from excessive temperatures by means of various internal sensors. If temperature thresholds are exceeded the entire unit may latch off, with no "ACOK" warning. To re-enable the unit, the AC mains must be disconnected for approximately 2 minutes.

Power De-rating

The RCB600 and MCB600 units must always be operated within its stated operating limits. Equipment manufacturers and other users must take appropriate de-ratings into account at all times when specifying a unit for the intended application. If in doubt, contact your sales representative or Roal Electronics for assistance.

There are two main de-ratings for the RCB/MCB power supplies, environment temperature and input line voltage. Temperature de-ratings apply to both input and output modules, while line de-ratings apply only to the input module.

For temperature, the de-rating for both input and output modules is 2.5% (of maximum rated power) per degree Celsius above 50 °C. While, for input line voltage, the de-rating for the input module only is 0.83% (of maximum rated power) per Volt below 120 V_{RMS} . These de-ratings can be calculated using the following conditional equations;

Equation for line de-rating:

If $V_{in} < 120 V_{RMS}$,

$$P_{out} = P_{rated} * \text{Line de-rating factor}$$

$$= P_{rated} * (1 - (0.0083 * (120 - V_{in})))$$

Otherwise,

$$P_{out} = P_{rated}$$

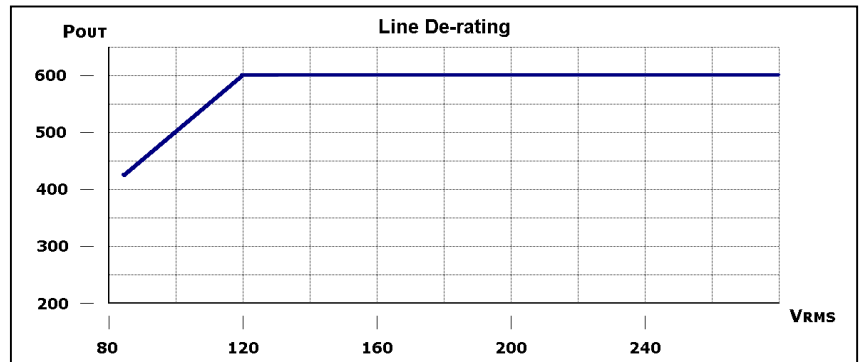

Equation for temperature de-rating:

If temp > 50 °C,

$$P_{out} = P_{rated} * \text{Temp derating factor}$$

$$= P_{rated} * (1 - (\text{Temp} - 50) * 0.025)$$

Otherwise,

$$P_{out} = P_{rated}$$

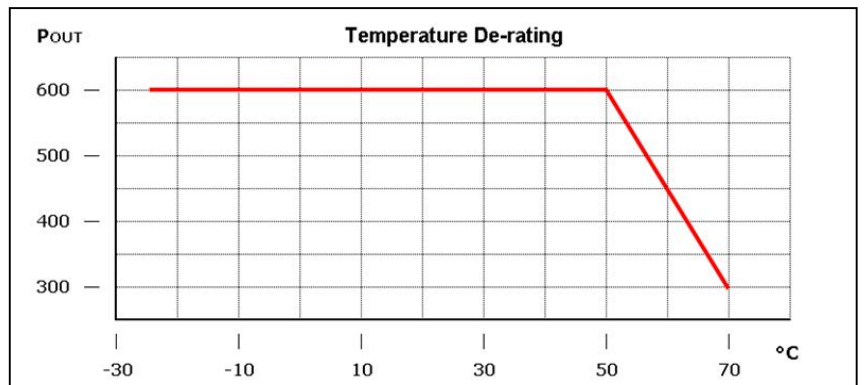

Depending on the application conditions, one or both of the de-ratings may apply. Where both apply, the de-rating factors given above can be multiplied together to obtain the total derating factor.

Example: What are the RCB600 input and output module deratings at 60 °C at 100 V line?

Input power rating	=	$P_{rated} * \text{Line de-rating factor} * \text{Temp de-rating factor}$		
Output power rating	=	$P_{rated} * \text{Temp de-rating factor}$		
Line derating factor	=	$(1 - (0.0083 * (120 - V_{in})))$	=	$(1 - (0.0083 * (120 - 100))) = 0.83$
Temperature de-rating factor	=	$(1 - (\text{Temp} - 50) * 0.025)$	=	$(1 - (60 - 50) * 0.025) = 0.75$
Input power rating	=	$600 * 0.83 * 0.75$	=	373.5 W
Output B/C/D power rating	=	$150 * 0.75$	=	112.5 W
Output A power rating	=	$125 * 0.75$	=	93.75 W

Efficiency

The efficiency of the overall unit is dependent on several parameters such as input voltage, load level and on the combination of output modules. The plots below show typical efficiencies of an RCB/MCB600 over the full line voltage and load range and fitted with four of each type of output module, equally loaded.

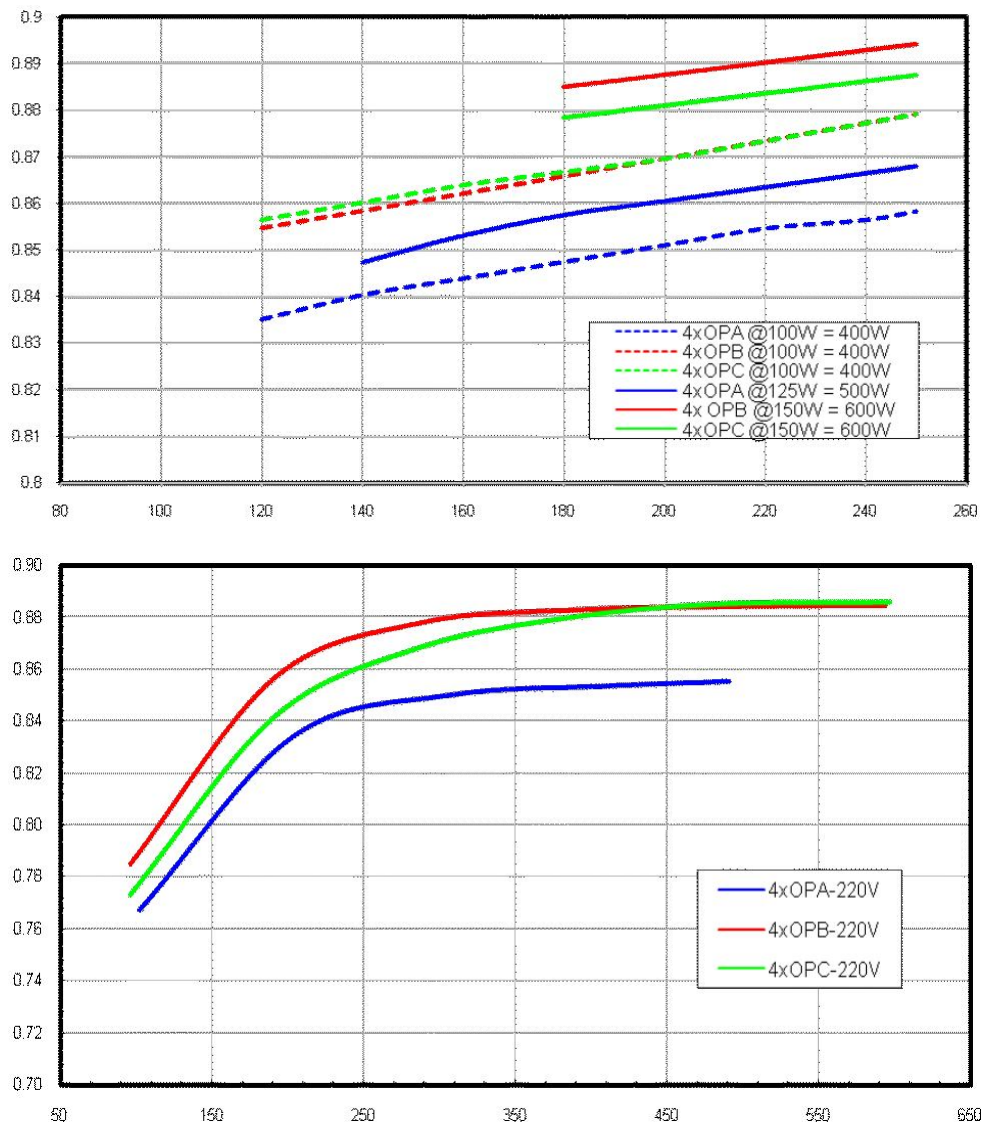

An estimate of the efficiency for any particular system may be obtained from these graphs using the procedure outlined in the example below.

Example: Estimate the efficiency of an RCB600-AABC, at 160 V_{RMS} input and 100 W load on each output?

1. Define load efficiencies for each output module at specified load and 220 V_{RMS} .
2. Define change in efficiency from 220 V_{RMS} to 160 V_{RMS} for each output module.
3. Sum the values from step one and two for each output module.
4. Calculate the average efficiency for the total system.

Step	Details	Slot 1 OP-A	Slot 2 OP-A	Slot 3 OP-B	Slot 4 OP-C
1	ϵ_{220} (Load chart)	0.85	0.85	0.88	0.88
2	$\Delta\epsilon_{(220-160)}$ (Line chart)	-0.01	-0.01	-0.01	-0.01
3	$\epsilon_x = \epsilon_{220} + \Delta\epsilon_{(220-160)}$	0.84	0.84	0.87	0.87
4	$\epsilon_{AVE} = (\epsilon_1 + \epsilon_2 + \epsilon_3 + \epsilon_4)/4$	0.855			

SIGNALS

To reduce cabling in the end system, all major input and output signals and the global +5V bias supply are wired to a single signals circuit that is accessed through the connector (J2) located at the output side of the chassis as shown in the diagram below.

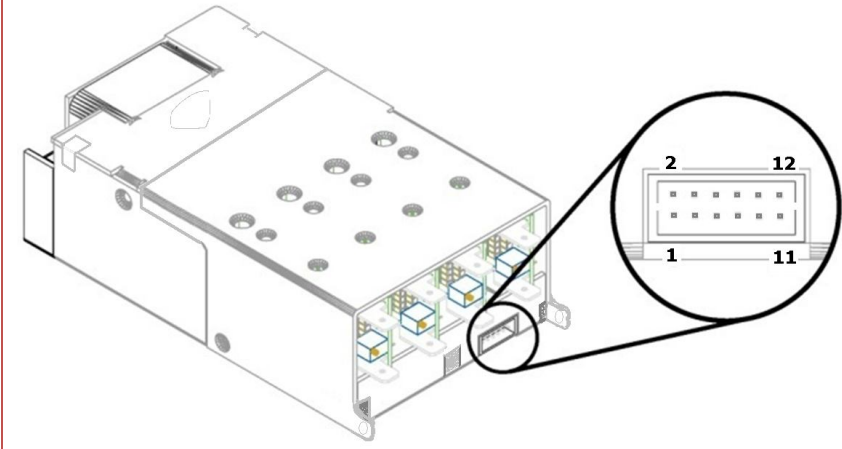

Pin	Name	Description	
1	PG1	Power Good	Slot 1
2	INH1	Inhibit	
3	PG2	Power Good	Slot 2
4	INH2	Inhibit	
5	PG3	Power Good	Slot 3
6	INH3	Inhibit	
7	PG4	Power Good	Slot 4
8	INH4	Inhibit	
9	GINH	Global Inhibit	
10	ACOK	AC mains signal	
11	+5V	Global 5V Bias	
12	COM	Common	

All of the signals are referenced to the bias supply common rail (COM) and external control and/or monitoring circuits can easily be powered and directly interfaced to the PSU through this connector. The entire signals circuit is fully medically isolated and can be considered a SELV output. The table below lists the isolation voltages.

Signals isolation voltages		
Signals to Input	4000	V_{AC}
Signals to Chassis	250	V_{DC}
Signals to Output	250	V_{DC}

+5V bias supply (Power Unit)

A +5 V bias supply that can deliver up to 200 mA is provided as standard on all units. This supply is available whenever the AC mains voltage is connected and the input module is operating correctly. To ensure safety, the following abnormal conditions may cause the entire unit to latch off, which will disable the +5 V bias supply:

- Over temperature of any part of the unit
- Over voltage on the output
- Internal over current (device failure)

AC mains signal _ ACOK (Output)

An ACOK signal is provided to indicate to the user that the AC mains voltage is applied and the input module is operating correctly. The output signal is driven from an internal operational amplifier as shown in the following diagram. Under normal operating conditions this signal gives a warning of 5 ms before the output voltage falls below the power good threshold. However, to ensure safety, the following abnormal conditions may cause the entire unit to latch off without an ACOK warning:

- Over temperature of any part of the unit
- Over voltage on the output
- Internal over current (device failure)

Power Good signals _ PG1-PG4 (Output)

Each output module provides a power good (PG) signal to indicate when the output voltage is above approximately 90% of the preset voltage for that module. Each PG signal on an output module is internally connected through an opto-isolator to the signals circuit, which buffers the signal through a PNP transistor with a 10 k Ω pull down resistor, as shown here on the side.

The LED on the front of each module gives a visual confirmation of the PG status.

Note that remote adjustments of the output voltage using the $V_{control}$ and $I_{control}$ pins do not change the PG signal threshold. The PG threshold is always approximately 90% of the voltage set with the manual potentiometer.

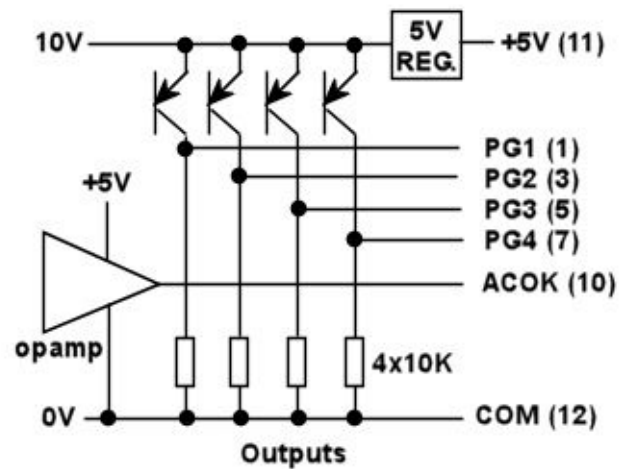

Output Inhibits _ INH1-INH4, GINH (Input)

The signals circuit provides four inhibit inputs to disable each output module individually and a fifth global inhibit input (GINH) to inhibit all modules simultaneously. Each inhibit input is internally connected through an opto-isolator to the respective output modules. The basic internal electrical circuit and timing diagrams are shown below. Typically, $t_{off} = 100 \mu s$ and $t_{on} = 8 ms$.

To inhibit each output module individually, GINH should be connected to COM, and +5 V applied to the appropriate input INH1/2/3/4. To start with all outputs inhibited and then enable them individually, GINH should be connected to +5 V, then pull down the appropriate input INH1/2/3/4. If GINH is left unconnected, then INH1/2/3/4 will all behave as global inhibit inputs. I.e. +5 V on any INH input will disable all outputs.

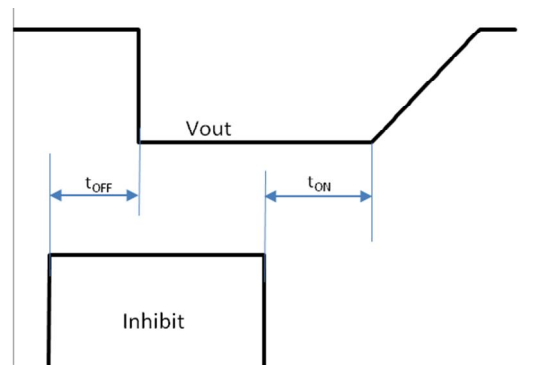
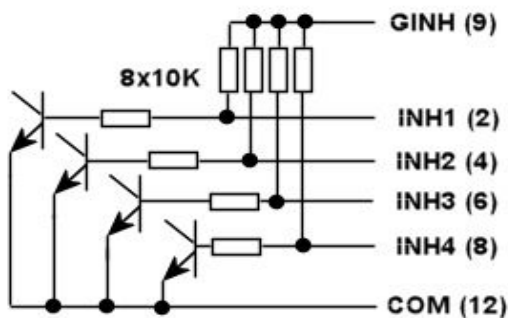

OUTPUT MODULE OPERATION

Power profile

The power profile diagram below is a voltage/current plot that together with the associated table provides details of the main features of the currently available output modules.

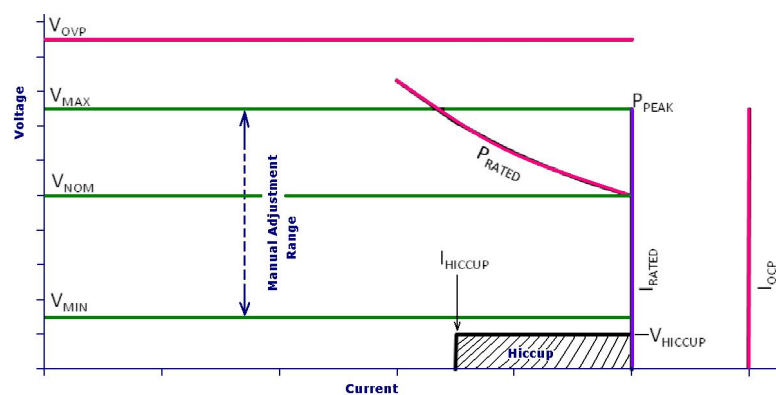

Parameter	OPA	OPB	OPC	OPD
V_{NOM} (V)	5	12	24	48
V_{MIN} (V)	1.5	4.5	9	18
V_{MAX} (V)	7.5	15	30	58
V_{OVP} (V)	9.5	17	32	66
I_{RATED} (A)	25	15	7.5	3.75
I_{OCP} (A)	27.5	16.5	8.25	4.12
V_{HICCUP} (V)	1	2	3.5	3.5
I_{HICCUP} (A)	22	13.2	6.6	3.3
P_{RATED} (W)	125	150	150	150
P_{PEAK} (W)	187.5	225	225	225

Output voltage adjustment

Each output can be adjusted within the range as described in the table above or in the datasheet. Voltage adjustment can be achieved by two methods;

1. Manual potentiometer adjustment

Using the manual adjust potentiometer, the preset output voltage (V_{SET}) of each output module is adjustable over the entire range of V_{MIN} to V_{MAX} as specified in the power profile table above. A clockwise rotation of the potentiometer results in an increase of the output voltage while an anti-clockwise rotation results in a decrease of the output voltage.

2. Remote voltage programming

Using remote voltage programming, the output voltage may be adjusted beyond the V_{MIN} and V_{MAX} range specified in the power profile table above. However, certain precautions must be taken to ensure correct operation. Please see the "Advanced output module features" section for more details.

Over Voltage Protection (OVP)

In the event of an output module fault, the modules are protected against excessive output voltages. This is implemented as a fixed voltage threshold (V_{OVP} , in the table above) and if the output voltage exceeds this threshold the entire power unit will be latched off. To resume operation of the unit, disconnect the AC input voltage for 2 minutes, remove the faulty output module and reconnect the AC input voltage.

Note that no warning is given on the AC_OK signal for faults of this type.

Over Current and Short Circuit Protection (OCP and SCP)

For increased safety and reliability all output modules in the RCB/MCB600 series have over current and short circuit protection. The over current threshold is typically set at 110% of the rated current and has a constant current, straight line characteristic that reduces the output voltage as the load resistance decreases. If the output voltages falls below the hiccup voltage threshold (V_{HICCUP}) the module enters short circuit protection mode. In this mode the output module uses a hiccup scheme to reduce system losses and potential damage. When in this mode, the output will be enabled for approximately 3% of the time, disabled for 97% and will attempt to restart at approximately 125 ms intervals. The module remains in this state until the short circuit condition is removed, at which point the module returns to normal operation.

Reverse Current Protection (RCP)

The standard output modules use synchronous rectification in the output stages to achieve high efficiency and as a result the outputs can both source and sink current. The sink current is internally limited to approximately -6% of the maximum rated current. However, in applications where the output modules are connected to external power sources such as batteries or other power supplies certain precautions must be observed to prevent damage to the unit.

The outputs should never be directly connected to external power sources without some form of reverse current protection such as an external diode or controlled MOSFET. If protection is not used, large reverse currents which will ultimately result in damage to the unit will occur, especially when the AC mains is disconnected.

Output module Average and Peak power

All modules have an average and peak power rating. The average power of each unit must at all times remain below its specified limit. However, each output can deliver up to 150% of its average power rating for a maximum of 5 seconds at 50% duty-cycle, subject to the current limit not being exceeded and subject to the overall average power drawn being less than the specified average power rating (including any input de-rating due to temperature or line voltage). The available peak power is a function of the output voltage and maximum current for each module. Full peak power is only possible when the output voltage is adjusted to V_{MAX} and the maximum current is drawn from the module. Note that both average and peak power ratings are subject to the same temperature de-rating as the input module (de-rate by 2.5% per °C above 50°C), but are not subject to any line de-rating.

Start up and Shut down

All outputs are designed to have a regulated monotonic start-up with a rise time of approximately 3 ms as shown in the diagram right. The power good signal stays low until the voltage exceeds the power good threshold ($\approx 90\%$).

Where multiple output modules are used, the default start up scheme is ratio-metric with all outputs starting at the same time as shown in the diagram right. External control circuits may be used to implement tracking or sequenced start up if necessary.

The outputs are not designed to start into a pre-biased load and may discharge any externally capacitance before beginning to ramp the output voltage up in the normal way.

At shut-down the outputs enter a high impedance state. Where no external load is present it may take some time for the voltage to decay. When driving inductive loads, care must be taken to limit the voltage at the output terminals so as to prevent damage to the unit.

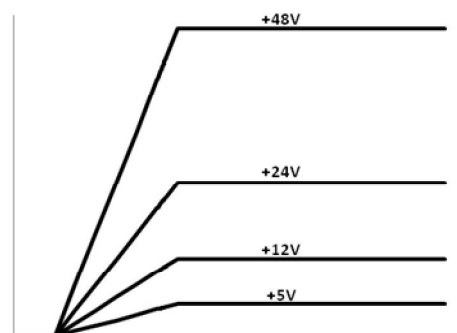
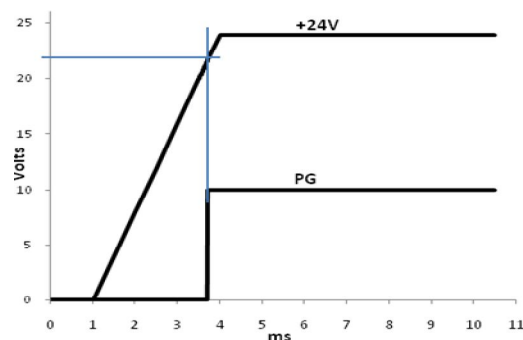

Synchronisation

All output modules in the same power unit are synchronised. The typical operating frequency is 260 kHz and paralleled/seriesed units will not produce beat frequencies.

Ripple and Noise

The ripple and noise figures stated in the datasheet are defined based on a standard measuring method. To obtain the same results the same test setup must be used and care must be taken to eliminate any parasitic noise pickup. The diagram below shows details of the setup and also sources of noise pickup.

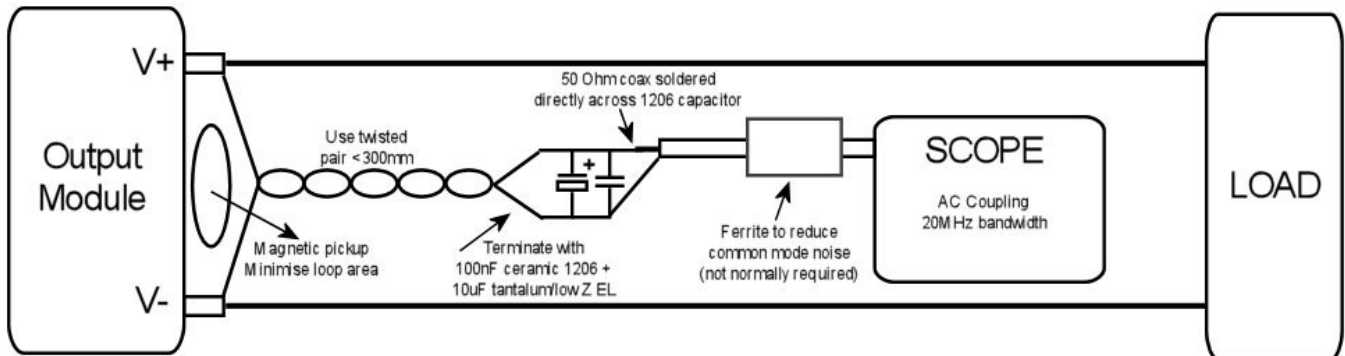

Over Temperature Protection (OTP)

Each output module is protected against excessive temperatures. In the event of the internal temperatures exceeding safe levels the entire unit may be latched off. To resume operation of the unit, disconnect the AC input voltage for 2 minutes, ensure external ambient temperatures are within specifications and then reconnect the AC input voltage. Note that no warning is given on the AC_OK signal for faults of this type.

Transient response

The RCB/MCB600 output modules have been especially designed to have high reliability, and to achieve this all electrolytic capacitors have been eliminated from the design. Due to this, high dynamic load transients can cause relatively high voltage deviations at the output and although the outputs have a very high loop bandwidth with typical recovery times of less than $100\ \mu\text{s}$, the voltage deviations may still be excessive for some applications.

An example application is detailed in the diagram below and shows typical responses at the terminals of the output module and at the load. Notice that the voltage deviation due to cable inductance exceeds the module response and hence a capacitor located at the module terminals will have little effect at the load. The optimum solution is to locate a low impedance electrolytic capacitor at the load which will eliminate the inductive cable drop and also reduce the typical voltage deviation at the module.

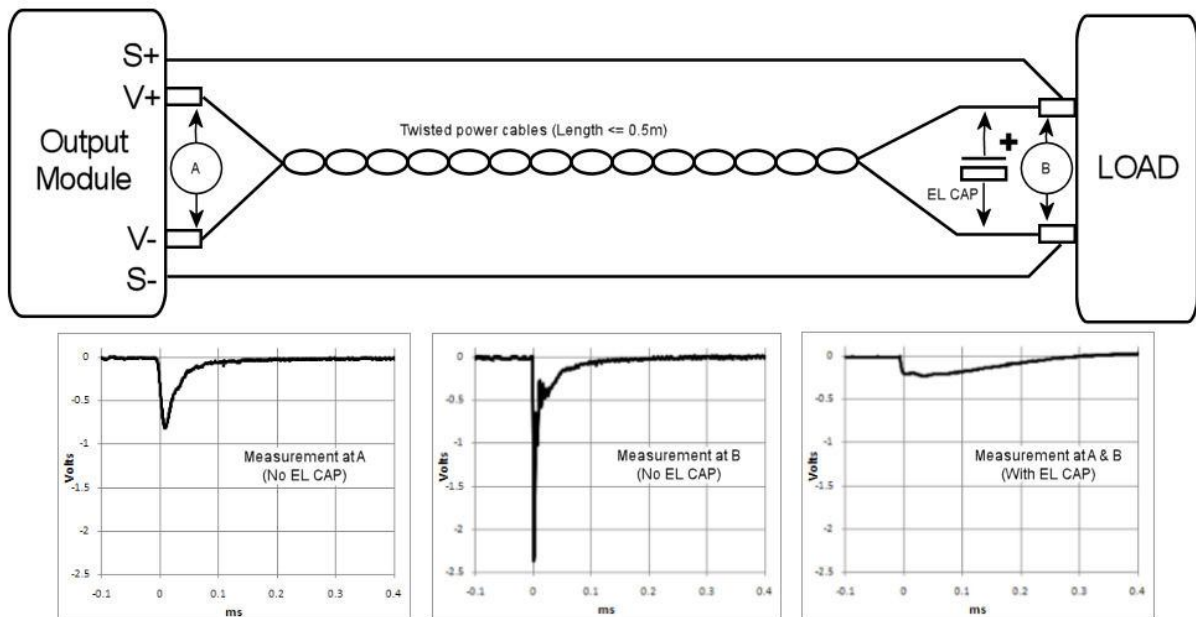

ADVANCED OUTPUT MODULE FEATURES

Remote voltage programming (External voltage control)

The output voltage of the module can be adjusted using an external voltage source connected between the COM and V_{control} pins on the signals connector (J5) as shown below.

In this configuration the output voltage will follow the equation below,

$V_o = V_{\text{set}} ((1.8 - V_{\text{ctrl}}) / 0.6)$, where V_{set} is the manual preset voltage of the module.

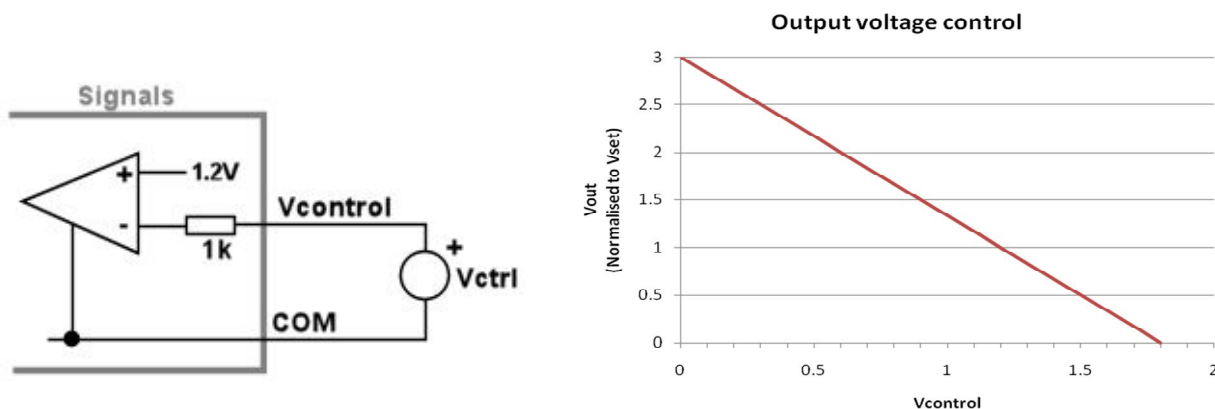

The output voltage can be controlled from 0% to 300% of the preset voltage using this control method. However, care must be taken to ensure the output voltage does not exceed the OVP level, as this is considered a safety hazard and will latch the entire unit off. To determine the level of control voltage that will trigger OVP, insert V_{ovp} into the equation above.

Example: $V_{\text{OVP}} = 9.5 \text{ V}$, $V_{\text{set}} = 5 \text{ V}$;

$$V_{\text{ctrl}} = 1.8 - (V_{\text{OVP}} * 0.6 / V_{\text{set}}) = 0.66 \text{ V}$$

Hence, V_{ctrl} should never fall below 0.66 V, otherwise OVP may latch the entire unit off.

Alternatively, by manually adjusting the output voltage to less than $1/3^{\text{rd}}$ of the OVP voltage ensures that OVP can never be tripped by remote voltage control.

Care must be taken to ensure the output voltage won't be forced too far below the V_{MIN} limit under maximum load operating conditions. Failing to do so, can lead to the output module electrical overstress and consequent damage.

Also, remote adjustment of the output voltage using the V_{control} pin does not affect the preset power good threshold. Hence, remotely adjusting the output voltage below $0.9 * V_{\text{set}}$ will cause the power good signal to go low.

Remote current programming (External voltage control)

The output current limit of the module can be reduced using an external voltage source connected between the COM and $I_{control}$ pins on the signals connector (J5) as shown below. In practice, this also means that the output can be used as a modulated or constant current source.

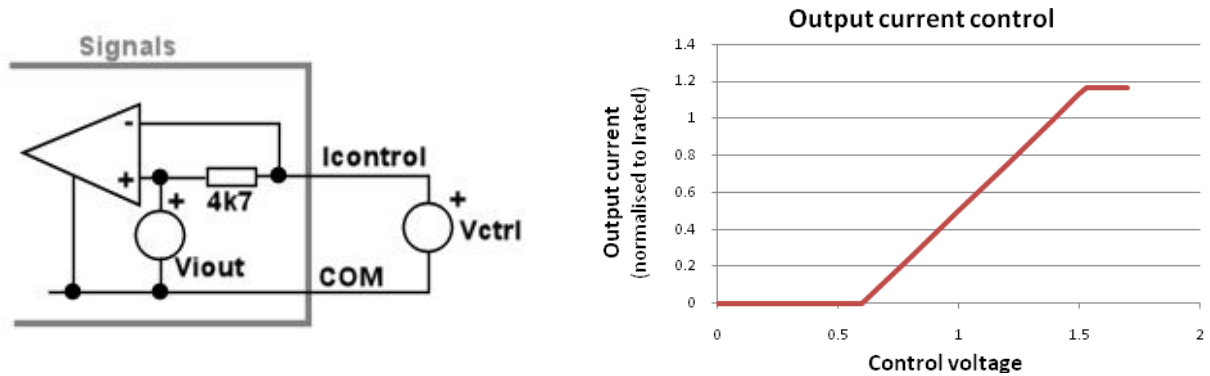

In the diagram above, $V_{i_{out}}$ is an internal voltage source that is proportional to the internal inductor current and approximates the equation,

$$V_{i_{out}} = 0.6 + (I_{out}/(I_{rated} * 1.25)), \text{ where } I_{rated} \text{ is the maximum rated current for the module.}$$

In this configuration the output current limit will approximate the following equation,

$$I_{limit} = (V_{ctrl} - 0.6) * I_{rated} * 1.25, \text{ where } I_{rated} \text{ is the maximum rated current for the module.}$$

It is not possible to increase the maximum current limit of the module, and control voltages (V_{ctrl}) exceeding 1.53 V will have no effect on the current limit.

When using an output module as a modulated current source, the output voltage should be manually adjusted to the maximum that will be required by the application and this will be the upper voltage limit. Once the load is connected, the output current can then be modulated by applying a control voltage as described above.

Note that the power-good threshold level is fixed and defined by the manually preset voltage. Hence, while the output module is limiting or modulating the output current this signal may go low.

Output current measurement

The output current of the module can be measured using the $I_{control}$ signal. If this pin is unloaded its output voltage will follow the equation, $V_{i_{out}} = 0.6 + (I_{out}/(I_{rated} * 1.25))$, where I_{rated} is the maximum rated current for the module.

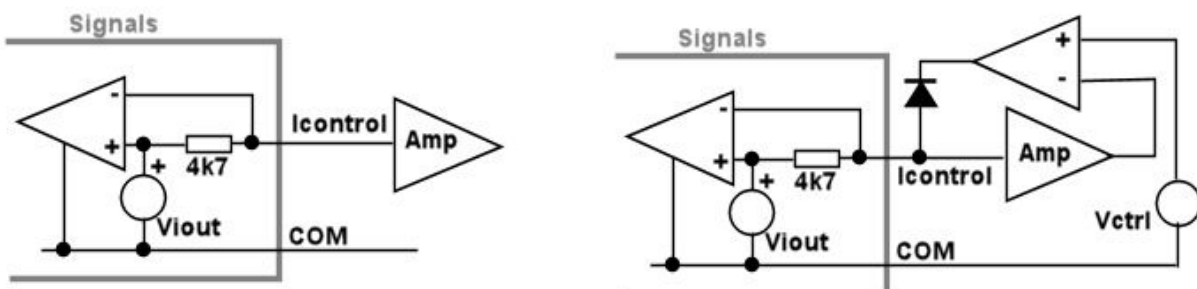

Note that the $I_{control}$ output voltage is representative of the internal inductor current not the actual load current. However, this will only have an influence during dynamic events. It is recommended to add an external amplifier (as shown above left)

when using the I_{control} signal to measure the output current as loading the I_{control} signal, even with microamps can cause the current limit to be reduced. If it is required to measure the output current and adjust the output current limit simultaneously, this can be achieved by using a clamp circuit instead of a voltage source to adjust the current limit, while continuing to use an amplifier to measure the output current. An example circuit is shown above right. In this case V_{ctrl} will control the current limit while the amplified I_{control} signal will provide a measurement of the output current.

Remote sensing

Remote sensing is available on all output modules and can be used to compensate for any voltage drop in the main power leads between the power supply and the load. To implement remote sensing connect the positive sense pin (S+, connector J5.2) to the positive side of the remote load and the negative sense pin (S-, connector J5.1) to the negative side of the remote load. The voltage will be regulated at the points where the sense cables are connected.

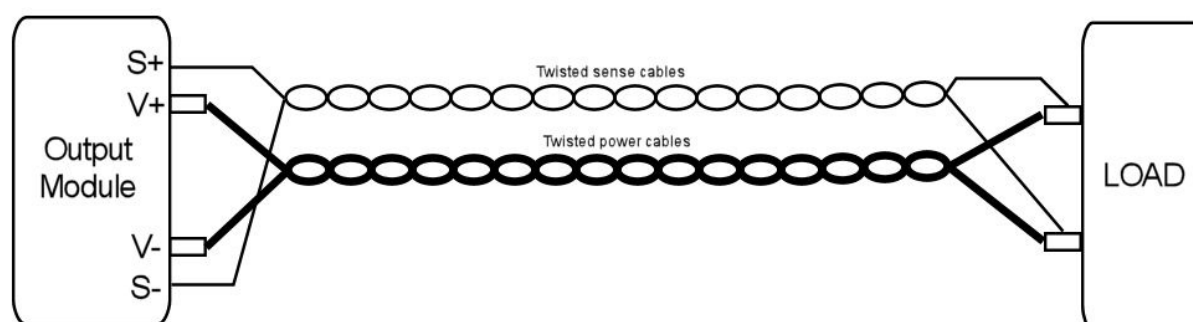

Active protection against worn out power cables or accidental power cable removal is provided and prevents damage to the unit in each case. An internal circuit measures the voltage between S+ to V+ and S- to V-, when this voltage exceeds the thresholds specified in the datasheet, the output voltage is reduced to benign levels. During system design, care must be taken to ensure power cables have a sufficiently low voltage drop at maximum load current to ensure this protection does not activate unintentionally.

In systems where remote sensing is not used, the output voltage at the power terminals will be slightly higher than that at the sense terminals. This voltage difference is termed, open sense off-set and occurs due to internal bias currents in the sensing circuit. Factory set units are set with the sense cables connected unless otherwise specified.

Local Bias supply

A local non-isolated +5 V bias supply is provided on each output module (+5 V on J5.6, referenced to COM on J5.5). This supply is intended to power interface circuits for monitoring and controlling the output modules, such as amplifying the current output signal as described earlier. The output can supply up to 10 mA maximum, and exceeding this can damage the unit.

Also, as COM is connected to an internal voltage that is **NOT** equivalent to S- or V-, particular attention must be given to grounding issues when interfacing COM to any control circuit in the application. Connecting COM to S- or V- may result in damage to the unit.

OUTPUT MODULES IN SERIES

RCB/MCB output modules of the same type can be seriesed in any number to achieve higher output voltages, even across multiple chassis. The following instructions must be followed for output modules configured in this manner.

WARNING!

Energy and voltage hazards may arise when individual modules are seriesed.
See the Safety section for more details.

Isolation to ground

Care must be taken not to exceed the output module isolation to chassis ground when seriesing outputs. Each output is rated for 250 V maximum between each output terminal and chassis ground. Exceeding this voltage may damage the unit.

Remote sensing

For seriesed modules, remote sensing is achieved by connecting the upper most positive sense terminal (S+) and the lower most negative sense terminal (S-) from the series of modules to their respective load regulation points. All inner sense terminals in the series must be daisy chained, S+ to S- from the first module in the series to the last module in the series. An example of two seriesed modules is shown below.

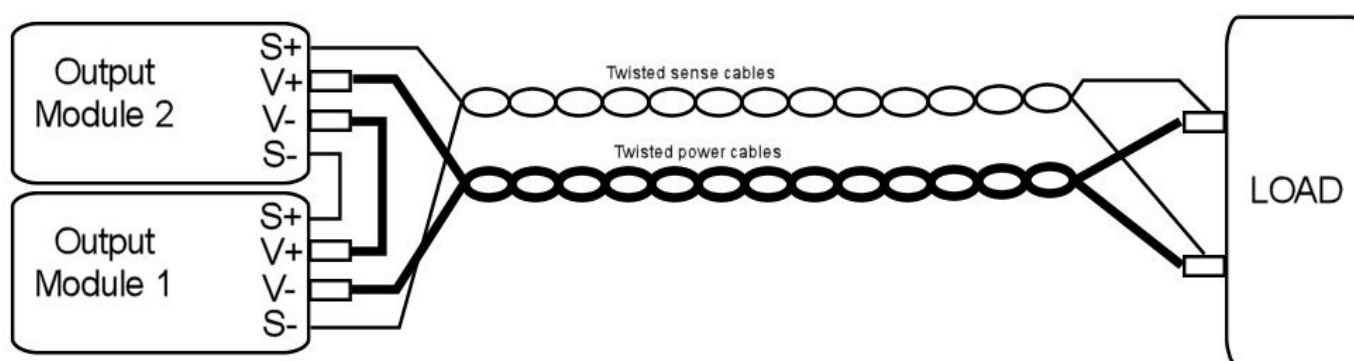

Seriesed remote voltage/current control

Remote voltage and/or current control is possible with any number of seriesed outputs using the advanced V_control and I_control functions as described earlier. However, individual control of each module can be complex as the various control terminals are referenced to the positive output of the preceding module and require the use of multiple isolated control voltages to attain control over the full voltage range. In practice, individual control of each module is rarely required and a more straightforward method is to control all outputs simultaneously with a single control voltage. With RCB/MCB output modules this is effortlessly achieved with the use of an external tracking circuit, details of which can be provided upon request. Using the external tracking circuits allows all modules in a series to be controlled by a single control voltage that can be referenced to the COM (J5.5) pin on any module.

SELV precautions

Where series combinations of output modules exceed 60 V, the output can no longer be considered SELV (Safety Extra Low Voltage) and hence the final equipment manufacturer must provide suitable protection for both users and service personnel.

OUTPUTS IN PARALLEL CONFIGURATION

RCB/MCB output modules of the same type can be paralleled in any number within the same chassis to achieve higher output currents.

WARNING!

Energy hazards may arise when individual modules are paralleled.
See the Safety section for more details.

For best performance, the output voltages of each paralleled module should be adjusted as close as possible. Follow the procedure below to achieve the most accurate results:

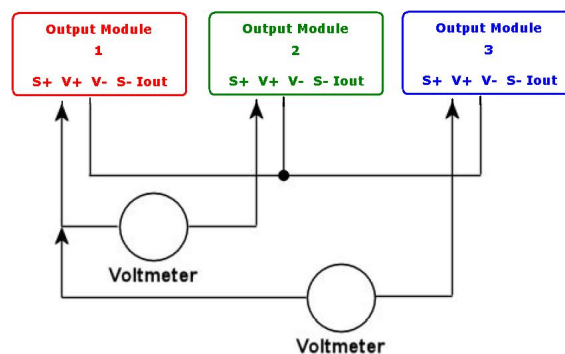

1. Connect all the negative power cables together.
2. Adjust the first module (1) to the desired voltage.
3. Connect a voltmeter between the positive terminal of the first module (1) and the positive terminal of the second module (2) and adjust the second module (2) until the voltmeter reads 0.000 volts.
4. Repeat step 3 for the remaining modules, always using the positive terminal of the first module (1) as the reference.

When paralleled, the outputs can operate in two distinct modes, Normal parallel mode or Share parallel mode.

Normal parallel mode

For normal parallel mode, the positive power cables should be connected together and the negative power cables should be connected together. No other connections are required as shown in the diagram below.

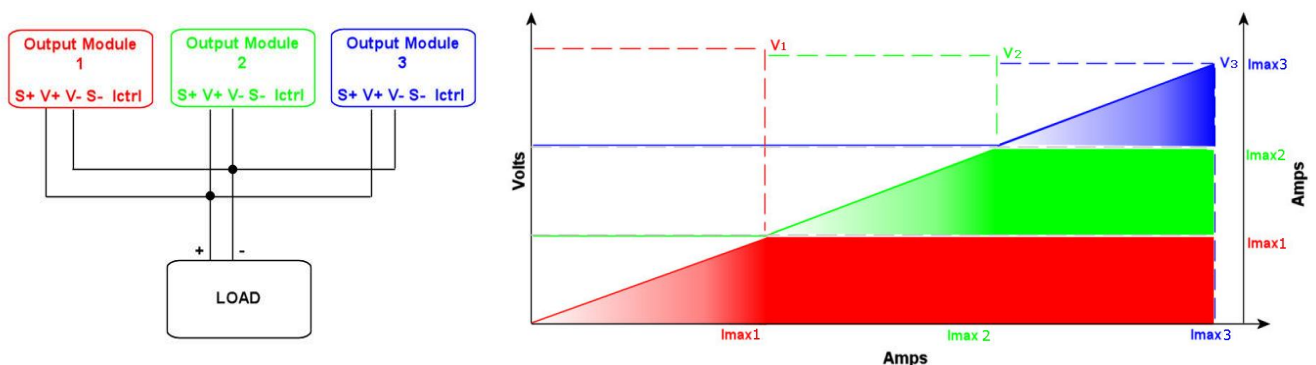

In this mode the highest adjusted output module will supply all of the load current until its current limit is reached. If the load demand exceeds this level the output voltage will drop to the level of the next highest adjusted module and that module will begin to supply the load current while the first module continues delivering full current. This process repeats for the total number of paralleled modules. The diagram above shows the V-I curve for such a system.

Output modules that are not delivering current will typically sink a small amount of current from the other outputs, but this will not exceed -6% of each modules maximum rated current.

Typically, system reliability is reduced as the higher adjusted modules will do most of the work with the lower adjusted modules only delivering current during peak load demand.

Share parallel mode

In Share parallel mode, the outputs are paralleled as before and the I_{ctrl} pin for each module is connected together as shown in the diagram below.

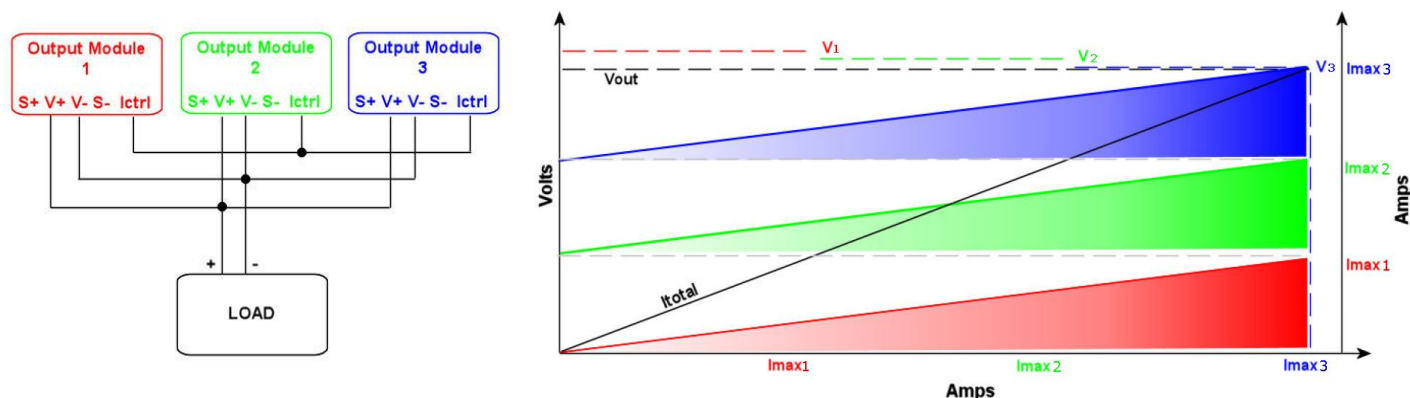

Connecting the I_{ctrl} pins together forces all the outputs to deliver the same current, ensuring that the system reliability is maximised and the work load is distributed evenly across all paralleled modules.

In this mode the lowest adjusted output module will determine the actual output voltage and all higher adjusted outputs will reduce their voltage. There may be a small amount of circulating current between the modules, approximately 6% of the maximum rated current for each module.

The current output signal (I_{ctrl}) can still be used to measure the output current but it must be scaled by N , where N is the number of paralleled modules.

WARNING!

Care must be taken to avoid differential voltages between the negative power output terminals of the paralleled modules as this can cause errors at the control pins. To avoid this, it is recommended that a low impedance connection be made between the negative power terminals close to the PSU output and cables then connected from this common point to the load.

Paralleling across multiple chassis

Paralleling across multiple chassis is not possible without external protection (such as external diodes or controlled MOSFETs) to prevent circulating currents between each chassis. Failure to provide such protection may result in damage to the units. Consult Roal Electronics for details on how best to implement such applications.

Where units are paralleled across multiple chassis, the outputs in each chassis will not be synchronised and the peak-to-peak output ripple may contain beat frequencies in the audio spectrum.

Parallel remote sensing

Remote sensing can be used as normal with paralleled modules. The sense lines (S+ and S-) from each of the output modules should be connected together, S+ to S+, and S- to S- as shown below. This should be done close to the power supply output and a single pair of cables brought from these sense lines to the load. Keeping cable lengths to a minimum and using twisted pairs where necessary will help reduce noise pickup in the sense lines.

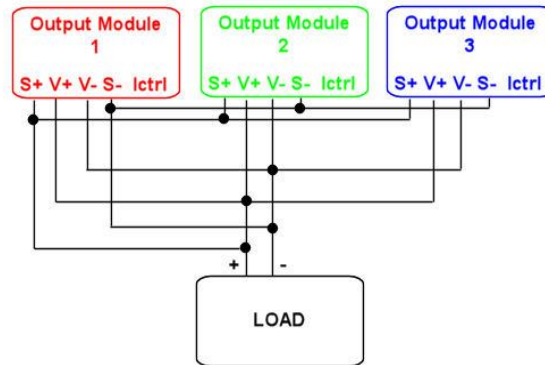

N+1 configurations

When using N+1 redundant configurations, a suitably rated diode (or controlled MOSFET) must be used on each output to prevent a device failure from causing a system failure. However, the diode introduces voltage drops between the supply and the load that significantly degrade the load regulation. To counteract this, the remote sense lines should be used to regulate the voltage at the load as shown below.

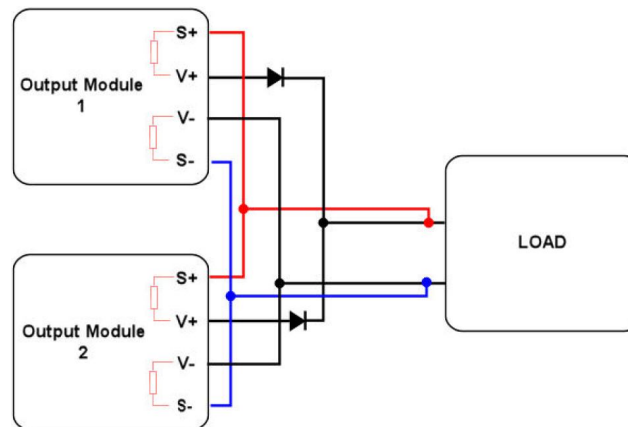

Typically this configuration can damage the internal sense resistors used within a power supply. However, the RCB/MCB outputs have integrated protection to prevent this type of damage and are completely N+1 compatible without any additional external protection circuitry. Note that only the positive sense terminal is protected and diodes should be used in the positive connection only.

Paralleled remote voltage/current adjust

The simplest way to achieve remote voltage/current programming with paralleled outputs is to operate the modules in share parallel mode. Follow the procedure outlined earlier to configure the outputs in share parallel mode and once configured in this mode, all the V_{control} and COM pins can be connected together. Remote voltage/current programming can then be performed exactly as with a stand-alone module.

It is not recommended to use remote voltage/current programming in normal parallel mode.

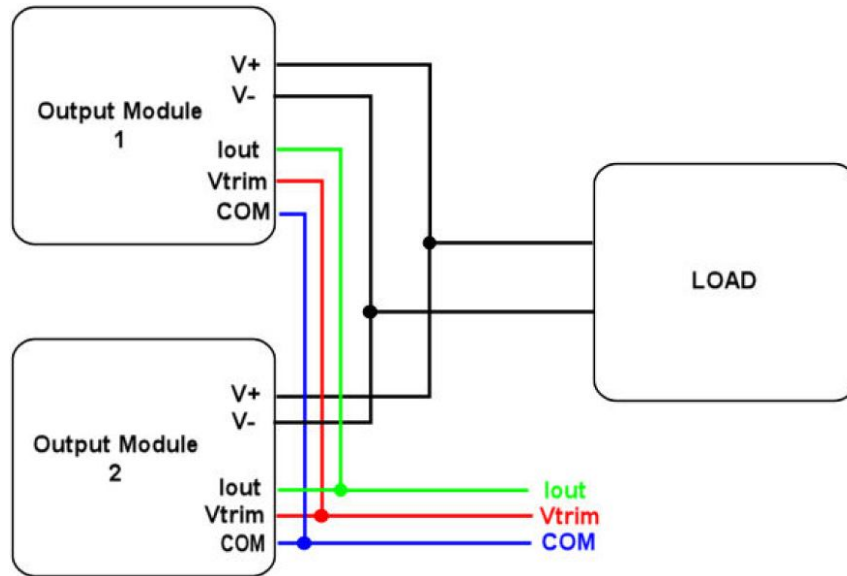

WARNING!

Care must be taken to avoid differential voltages between the negative power output terminals of the paralleled modules as this can cause errors at the control pins. To avoid this, it is recommended that a low impedance connection be made between the negative power terminals close to the PSU output and cables then connected from this common point to the load.

MECHANICAL _ DIMENSIONS AND MOUNTING

Specifications	Details	Nominal	Units
Dimensions	Height is 1U	77.7 x 136.3 x 41.0	mm
		3.06 x 5.36 x 1.61	in
Weight	Chassis + Input	450	g
		0.99	lb
	Output modules	45	g
		0.10	lb
Mounting	Bottom or side mounting through M4 screws		

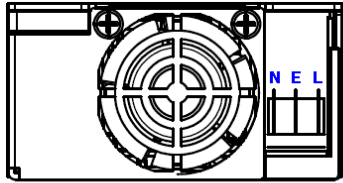

N - Neutral
E - Earth
L - Live

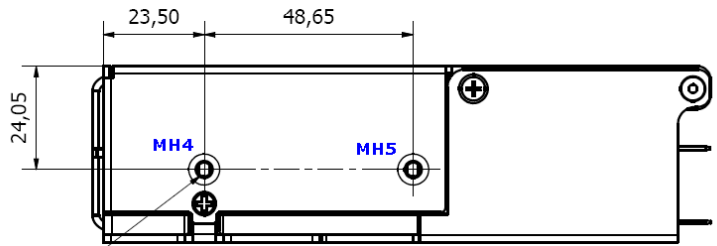
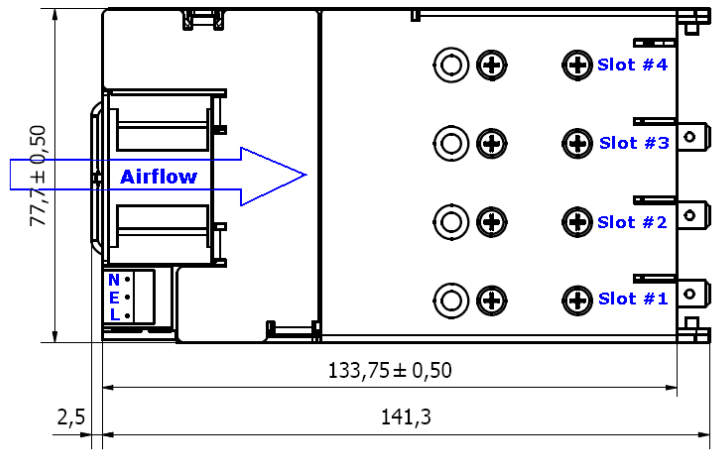
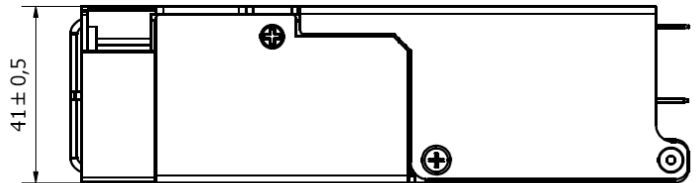

M4 (2x) ∇ 4 mm (max)

M4 (3x) ∇ 4 mm (max)

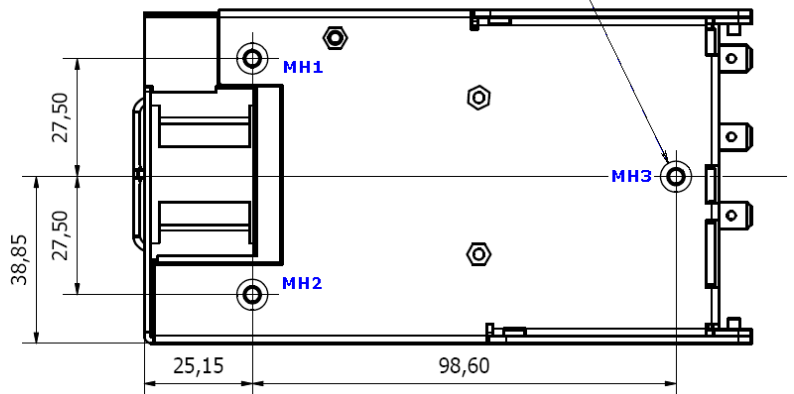

SCREWS	
MH1, MH2, MH3, MH4, MH5	
Screw type	M4
Tightening torque	Tighten to 1.5 Nm
Penetration depth	4.00 mm max, including chassis
OUTPUT MODULES X 8	
Screw type	M3X5, C/Sink, Pozidriv, Stainless steel
Tightening torque	Tighten to 0.75 Nm
Penetration depth	Defined by screw
CHASSIS X 2	
Screw type	M3X5, C/Sink, Pozidriv, Stainless steel
Tightening torque	Tighten to 0.75 Nm
Penetration depth	Defined by screw
CHASSIS X 2	
Screw type	M2.5X4, C/Sink, Pozidriv, Stainless steel
Tightening torque	Tighten to 0.45 Nm
Penetration depth	Defined by screw
FAN X 2	
Screw type	M3X30, C/Sink, Pozidriv, Stainless steel
Tightening torque	Tighten to 0.70 Nm
Penetration depth	Defined by screw

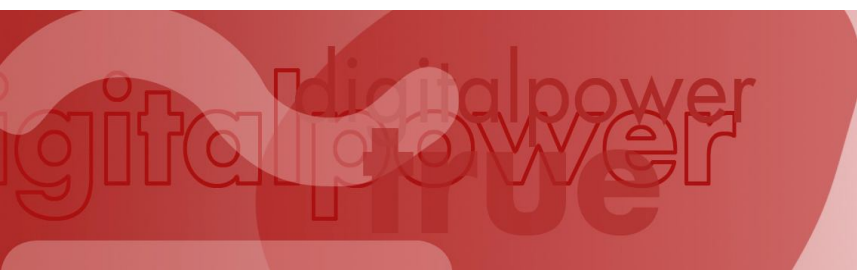

MECHANICAL _ CONNECTORS AND PIN ASSIGNMENT

PIN ASSIGNMENT	
Circuit	Details
J1	
1	Neutral
2	Earth
3	Live
J2	
1	Power Good Slot #1
2	Inhibit Slot #1
3	Power Good Slot #2
4	Inhibit Slot #2
5	Power Good Slot #3
6	Inhibit Slot #3
7	Power Good Slot #4
8	Inhibit Slot #4
9	Global Inhibit
10	AC OK
11	+5V 200mA, Bias Supply
12	COM
J5	
1	-Sense
2	+Sense
3	Voltage Control
4	Current Control Current Sharing Current Monitor
5	COM
6	+5V 10mA, Bias Supply
J3	
Positive Output	
J4	
Negative Output	

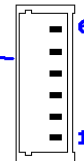
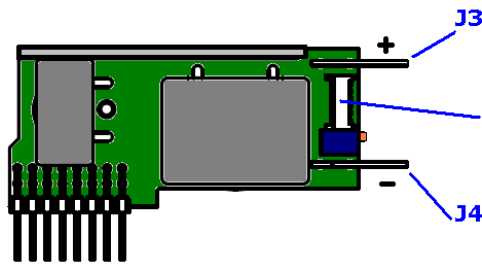
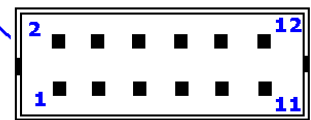
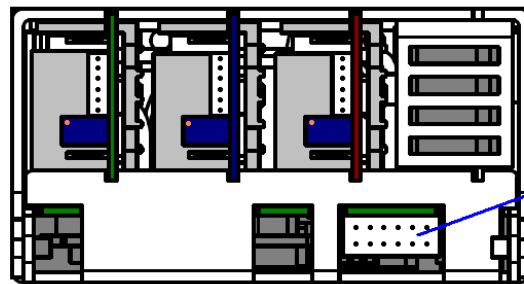
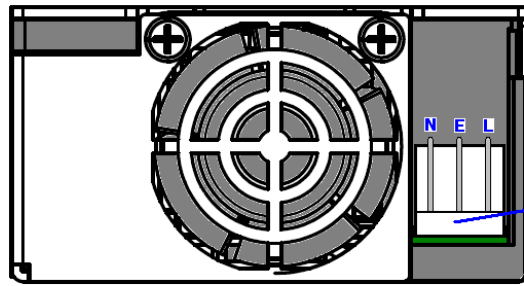

COUNTERPART CONNECTORS				
Reference	Details	Manufacturer	Housing PN	Terminal PN
AC Mains Input J1	<ul style="list-style-type: none"> 5.08 mm (0.200 in), 3 circuits housing, with friction lock, or, any direct equivalent. Crimp terminal, 18-24 AWG, tin finish, or, any direct equivalent. 	Molex	0010013036	0008701031
Power Unit Signal J2	<ul style="list-style-type: none"> 2.00 mm (0.079 in) 12 circuits housing with locking ramp, or, any direct equivalent. Crimp terminal 24-30 AWG, gold finish, or, any direct equivalent. 	Molex	0511101260	0503948051
Output Power J3/J4	<ul style="list-style-type: none"> Quick Disconnect Receptacle compatible with PCB mounting TAB, size 0.80X6.35 mm. Tin finish. 	Vogt AG Tyco Electronics	NA	3967 640907-1
Output Signal J5	<ul style="list-style-type: none"> 1.25 mm (0.049 in), 6 circuits housing, Crimp terminal 28-32 AWG, tin finish, or, any direct equivalent 	Molex	0510210600	050058800

Notes:

- Output power terminal and wire current rating must exceed maximum short circuit output current.
E.g. OP-A: 25*1.25 = 31.25 A.
- Direct equivalents may be used for any connectors parts
- All cables must be rated 105°C min, equivalent to UL1015.



CONFIGURING YOUR POWER SUPPLY

The RCB/MCB600 power supply is designed to be used as part of an end-system in a restricted environment and therefore should only be accessible to qualified and trained personnel. Persons attempting to configure a unit must have the necessary knowledge and training before doing so. Incorrect configuration may cause damage to the power supply and may affect its warranty.

Output power modules (OP-A, OP-B, OP-C, OP-D) may be added, replaced or moved by strictly following the sequence of operations described here below.

Please contact ROAL Electronics or your distributor for assistance in configuring your power supply.

Step 1:

Remove the AC input line connection and all other connections from the power supply. Remove the unit from the system where it could be applied.

WARNINGS!

Leave the unit to stand for a minimum of 3 minutes after removing all power and other connections from the unit before attempting to configure or re-configure the power supply.

Always remove the power supply before handling. During operation, the external surface of the unit can become hot. Leave the unit to stand for 10 minutes for cooling down before handling.

Dangerous voltages are present within the power supply. Covers may only be removed by qualified personnel when the power supply has been disconnected from the mains supply voltage for more than 3 minutes. Covers must be replaced and all screws secured properly before reconnecting to the mains voltage.

Step 2:

Remove the two screws that secure the hinged lid to the chassis.

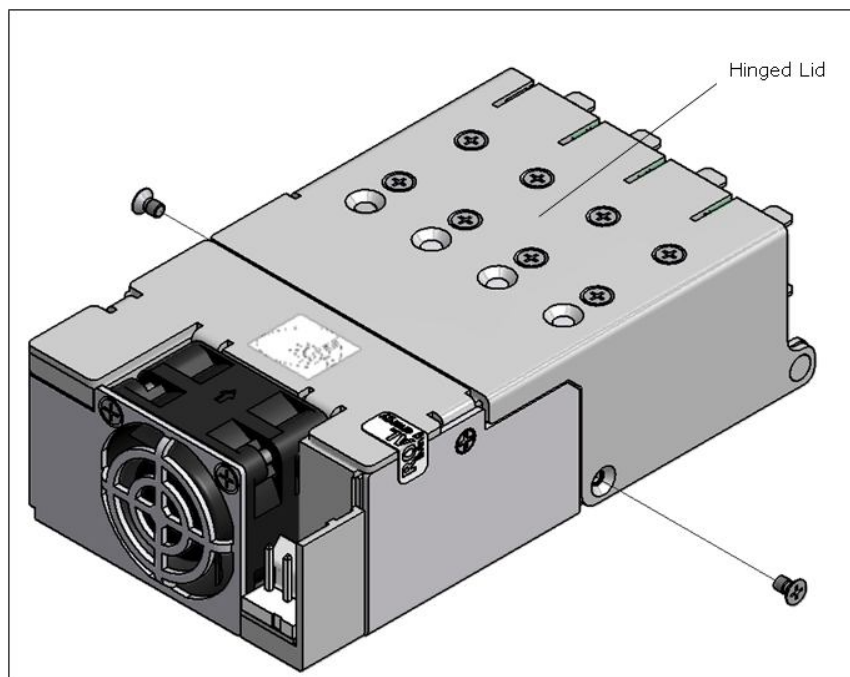

Step 3:

Each output module (OP) or blanking plate (BP) is secured to the pivoted lid through a couple of screws. A power supply, however configured, does have four pairs of screws visible on the upper surface of the lid. When re-configuring a power supply only remove the screws that hold an OP while leaving tightened BP's ones.

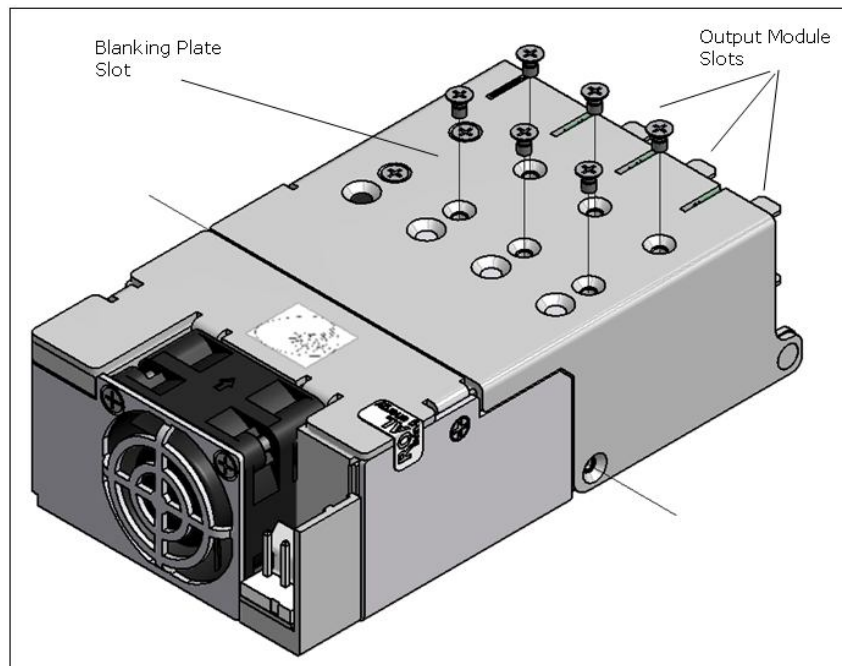
**Step 4:**

Removed all the screws that hold the OPs, the next step involves opening the lid by rotating it around the two pivots that bind it to the chassis. Ensure that all the output modules are loose from the lid, before doing so.

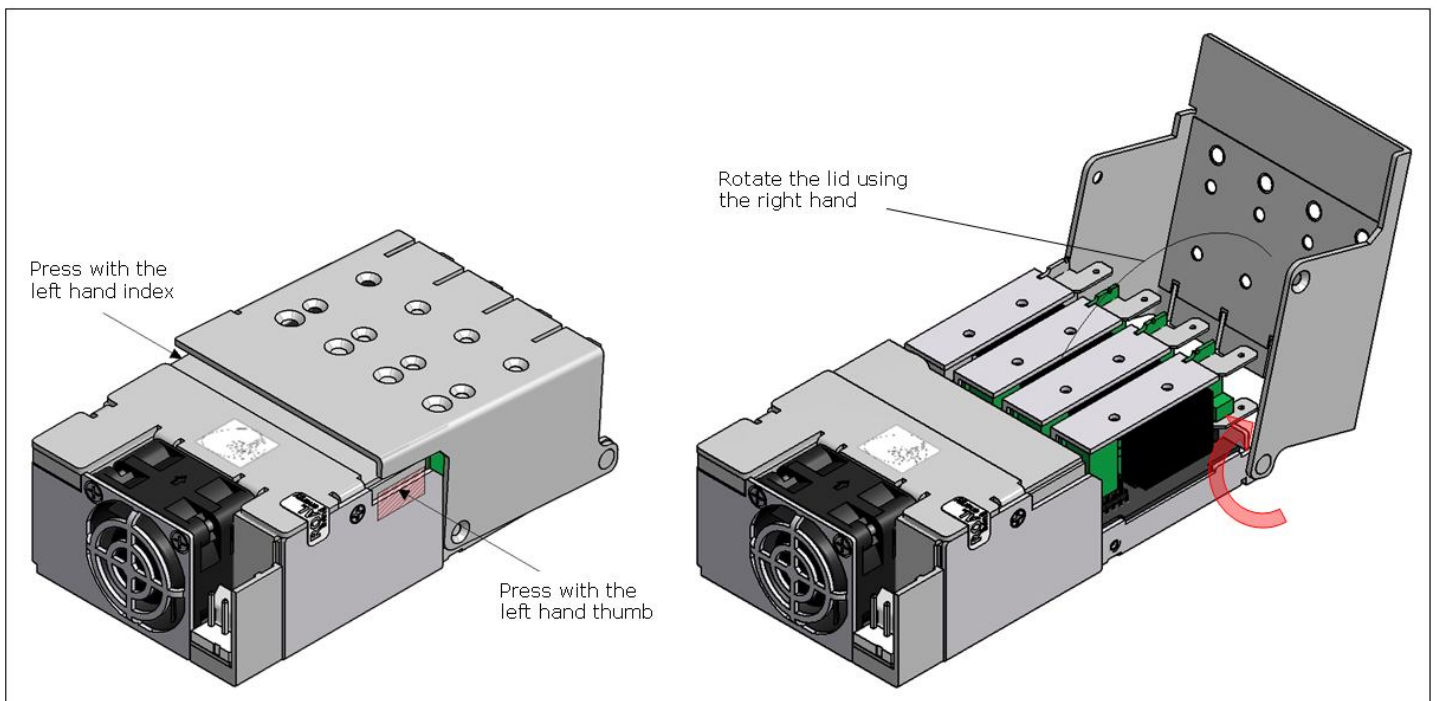

Once the cover has been rotated at the most comfortable angle, it is possible to remove any BPs as required by the new configuration needed.

Step 5:

With the lid properly rotated, the OPs can be removed and replaced as required. In case the power supply is fully populated by four OPs (one output module for each slot), to remove them start with slot #1. Hook one finger underneath the output module heat-sink, near the back, and lift it out while holding down the main chassis. Repeat this for slots #2, 3# and finally slot #4 in sequence. To replace or install new OPs, use the reverse order when plugging.

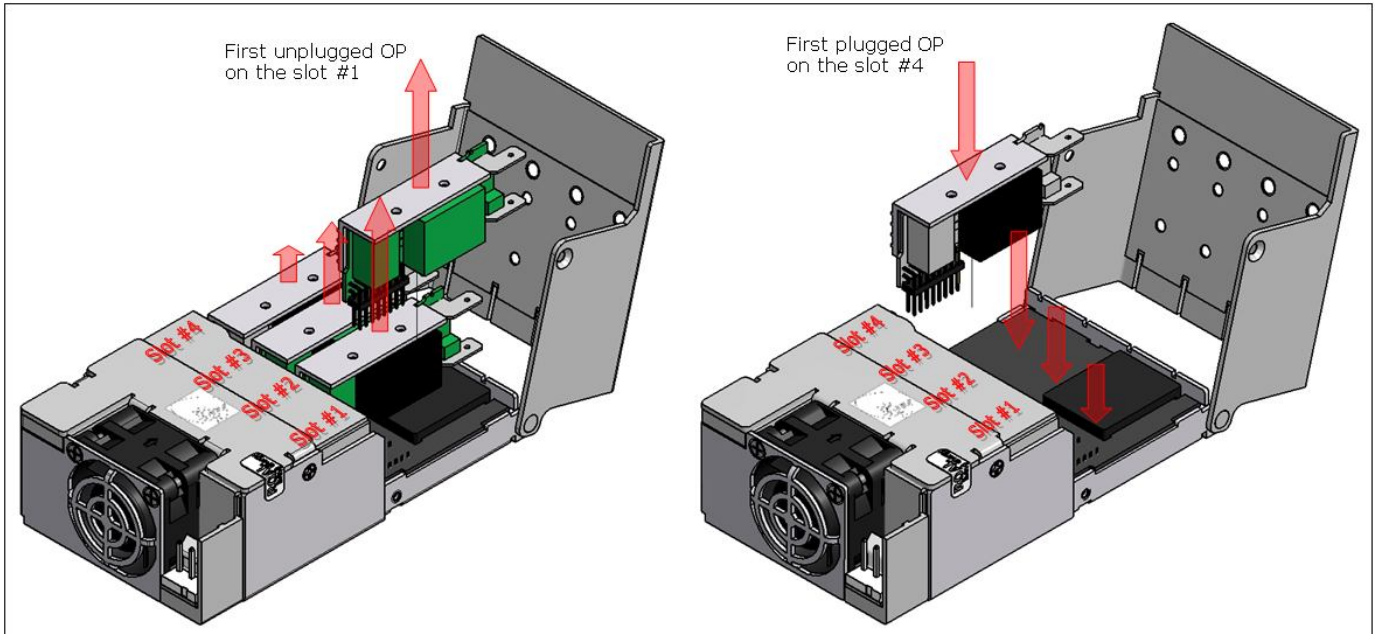

To replace or install new OPs, a 15 pins header must be plugged directly into the mating connector on the unit printed circuit board (PCB). To do so, simply align the connector and push the OP properly down securing it in the notch at the back of the chassis as shown below. Each connector is keyed to prevent improper insertion.

Step 4:

Once the modules are replaced and the new configuration is complete, the lid can be closed again. Doing this, exercise extreme care so that all the OPs PCBs are ensured together in the chassis notches and aligned with the lid slots (see drawing below). Closure movement should neither encounter obstructions nor require an excessive force.

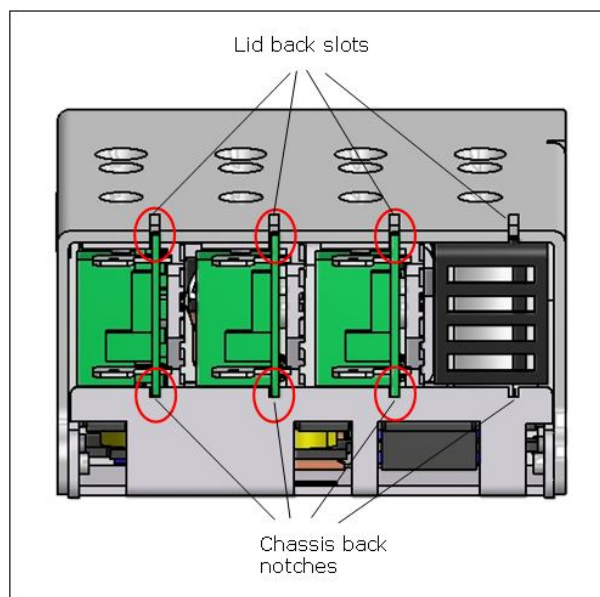

A blanking plate must always be used whenever a slot does not contain an output module. Any blanking plate should be secured to the lid before closing it. To facilitate operations, the BPs should be assembled before the OPs.

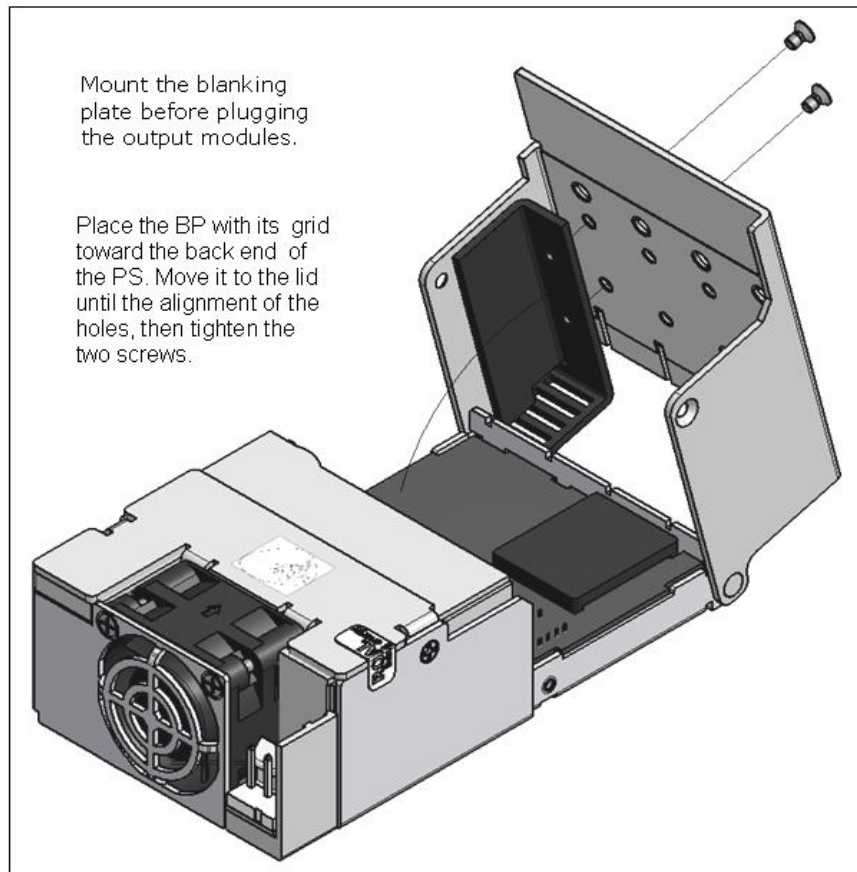

As evidence of power unit proper closing, output modules PCBs must be properly housed in the notches and in the slots of the chassis and cover respectively, mechanical parts and screws holes must be aligned without exerting any effort.

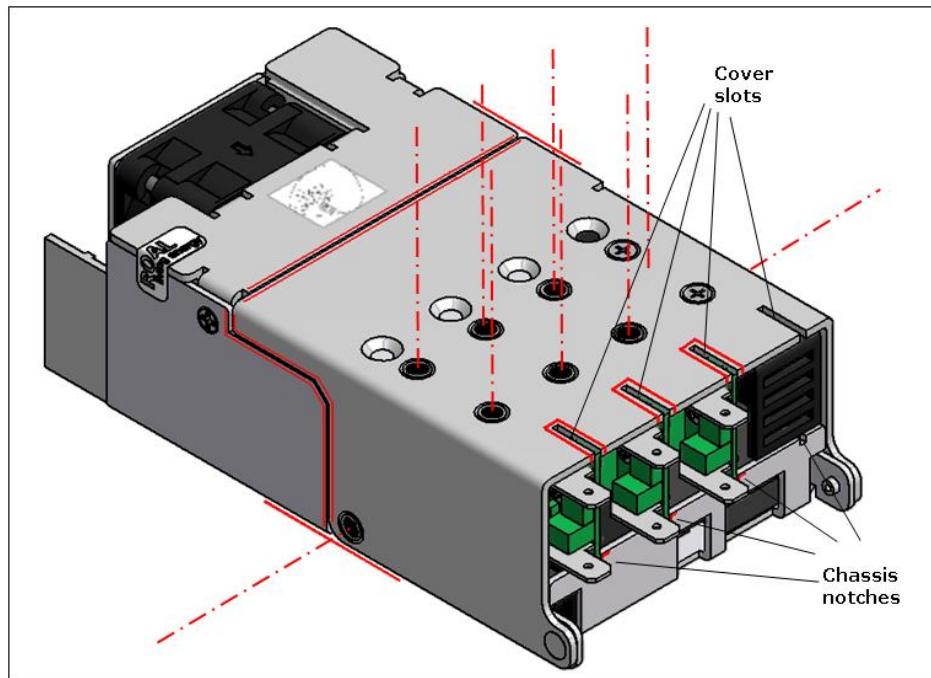

Step 5:

Insert all the screws and tighten them as required in the table above. Always use the appropriate tooling (Pozidriv point size:1) and do not over tighten.

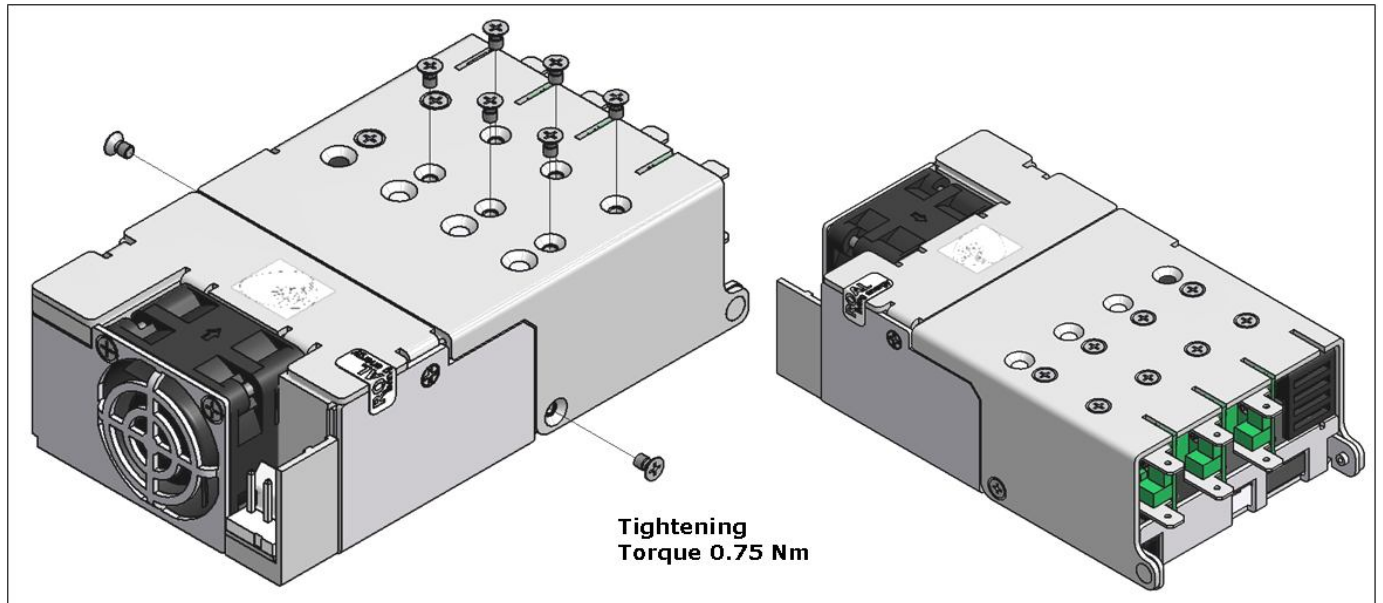
**WARNING!**

Do not apply power to the power supply before replacing the lid and securing all the screws.

Never remove the cover secured on the input side of the chassis. It is sealed by a tamper evident security label.

Removing it makes accessible high voltage parts exposing a operator to electric shock danger. Any alteration affecting the label will void the warranty on the Power Supply.

Step 6:

Reconnect the AC line input and apply power to ensure all the output modules are working by checking their LED light comes on. Always check the output voltage of each module to ensure it is adjusted to your requirements. Remove power and connect all other cables. The power supply is now ready for use.

SAFETY

The RCB/MCB600 unit has been designed to comply with the Low Voltage Directive (LVD) 2006/95/EC and is CE marked to show its compliance.

When correctly installed (according to the RCB600/MCB600 installation manual) in a limited access environment, the RCB600 complies with the requirements of UL60950-1, EN60950-1, IEC60950-1, CSA22.2 no. 60950-1 and the MCB600 complies with the requirements of UL60601-1, EN60601-1, IEC60601-1, CSA22.2 no 601-1.

The power supply should not be operated close to combustible materials or atmosphere.
Care should be taken to ensure liquid or metal shavings do not enter the power supply as this can cause a fire hazard.
The power supply does not contain any user serviceable parts and should be returned to Roal Electronics for repair.

Approval limitations (NORTH AMERICA)

When this product is used with 180 V_{AC} – 253 V_{AC} mains where no neutral is present, connect the two live wires to L (Live) and N (Neutral) on the input connector.

WARNING!

Modules in series with combined voltages exceeding 60 V are not considered SELV. Modules in series and/or in parallel with combined energy ratings greater than 240 VA may cause energy hazards. The equipments manufacturer must provide additional and adequate protection to service and technical personnel.

Always remove the power before handling the unit. During operation the external surface of the unit can become hot. Leave to stand for 10 minutes to allow the unit to cool down before handling it.

Dangerous voltages are present within the power supply. Covers may only be removed by qualified personnel when the power supply has been disconnected from the mains supply voltage for more than 3 minutes. Covers must be replaced and all screws secured properly before reconnecting to the mains voltage.

Parameter	Details	Min	Max	Units
Isolation voltage	Input to Output		4000	V _{AC}
	Input to Chassis		1500	V _{AC}
	Output to Chassis		250	V _{DC}
	Output to Output		250	V _{DC}
Isolation clearance	Primary to Secondary (Reinforced)	7		mm
	Primary to Chassis (Basic)	2.5		mm
Isolation creepage	Primary to Secondary (Reinforced)	12		mm
	Primary to Chassis (Basic)	4		mm
Leakage current	Medical: 265 V _{AC} , 63 Hz, 25 °C		300	μA
	Standard: 265 V _{AC} , 63 Hz, 25 °C		1500	
Agency Approvals	cUR _{US} , Demko, CB Certificate			
Standards	IEC/EN60950-1, 2 nd Edition; UL60950-1/CSA C22.2 No. 60950-1-03, 2 nd Edition.			
	IEC/EN60601-1; UL60601-1/CSA C22.2 No. 601-1.			
	CE Mark: LVD 2006/95/EC.			
Agency File Numbers	UL Test Report : E134098-A35-UL (RCB600); E304543-A3-UL (MCB600). Demko Certificate: D-152969-02 (RCB600); D-152492-03 (MCB600). CB Test Certificate: DK-21001 (RCB600); DK-20543-M1 (MCB600).			

EMC COMPLIANCE

To support compliance of the final system design with the EMC directive 2004/108/EC, the RCB/MCB600 PSU has been designed and tested to the following standards.

Parameter	Standard	Level
Emissions		
Radiated electric field	EN55011, EN55022, FCC	B
Conducted emissions	EN55011, EN55022, FCC	B
Harmonic distortion	EN61000-3-2	Compliant
Flicker and fluctuation	EN61000-3-3	Compliant
Immunity		
Electrostatic discharge	EN61000-4-2 (15 kV air, 8 kV contact)	4
Radiated RFI	EN61000-4-3 (10 V/m)	3
Fast transient burst	EN61000-4-4 (4 kV)	4
Input line surges	EN61000-4-5 (1 kV L-N, 2 kV L-E)	3
Conducted RFI	EN61000-4-6 (10 V)	4
Power freq. Magnetic field	EN61000-4-8 (10 A/m)	3
Voltage dips	EN61000-4-11 (EN55024)	Compliant

For radiated and conducted emissions, compliance of the final system relies on proper installation of the PSU component. The installation guidelines detailed below should be followed.

Installation guidelines for EMC

The RCB/MCB600 units should be mounted within a metal enclosure using the mounting fixtures provided. If the application enclosure is not metal then a metal ground plate should be used to mount both the power supply and the load.

Decoupling the loads to the chassis or ground plate with suitably rated 100 nF capacitors can assist in reducing emissions.

Both input and output cables should be fixed as close as possible to the ground plate or metal enclosure. Also, input and output cables should be separated as much as possible.

Output power and sense cables should be twisted pairs and routed parallel to each other. Do not twist sense and power cables together.

All cables lengths and loop areas should be minimised.

Where cables must enter or exit the enclosure, good high frequency 100 nF decoupling capacitors of sufficient voltage rating should be connected to the cables as close to the entry/exit point as possible.

For further details or assistance contact Roal Electronics.

RELIABILITY

The RCB/MCB600 series has undergone extensive testing, including HALT and Environmental testing.

Reliability data is collected on an ongoing basis. Please contact ROAL Electronics or your distributor for the most up-to-date reliability data.

Roal Electronics, S.p.A. may change product specifications and accordingly the information presented in this document. Customers are responsible for their products and applications using Roal Electronics, S.p.A. products. Roal Electronics, S.p.A. assumes no liability from the use of its products outside of specifications. No license is granted to any intellectual property rights by this document. ROAL ELECTRONICS, S.P.A. DISCLAIMS ALL REPRESENTATIONS AND WARRANTIES OF ANY KIND, EXPRESS OR IMPLIED, INCLUDING, BUT NOT LIMITED TO, IMPLIED WARRANTIES OF NONINFRINGEMENT, MERCHANTABILITY AND FITNESS FOR A PARTICULAR PURPOSE.

Eu and RoW

ROAL Electronics S.p.A
Via Jesina 56/A
60022 – Castelfidardo (AN) – Italy
Tel: + 39 071 721461
Fax: + 39 071 72146 480

<http://www.roallivingenergy.com/>

North America

ROAL Electronics USA, Inc.
701, Main St. Suite 405
Stroudsburg, PA18360
Phone: + 1 570 421 5750
Fax: +1 570 421 5687
Rev. 00 _ February 18th 2011