



Allen-Bradley

***1785-KE Data
Highway Plus
Communication
Interface
Module***

(Cat. No. 1785-KE)

User Manual



Table of Contents

Using This Manual	2
Chapter Objectives	2
Purpose of This Manual	2
Who Should Read This Manual	2
Series B Enhancements	3
Frequently Used Terms	3
Precautionary Notes	4
Related Products	4
Related publications	5
Overview of the 1785-KE and Data Highway Plus	1
Chapter Objectives	1
What is the 1785-KE Module?	1
What is Data Highway Plus?	2
The Physical Link Layer	3
Delivery Order of Commands	7
Applications	8
Installing the 1785-KE	1
Chapter Objectives	1
Setting the Communication Option Switches	1
Switch Assembly SW-1: RS-232-C Link Features	3
Switch Assembly SW-2: Data Highway Plus Node Address	5
Switch Assembly SW-3: Communication Rates and Local/Remote Option	8
Switch Assembly SW-4	9
Mounting the 1785-KE Module	10
Making Connections to the 1785-KE	11
Powering Up the 1785-KE Module	13
Connecting Your RS-232-C Device to the 1785-KE	1
Chapter Objectives	1
The RS-232-C PORT Connector	1
Electrical Characteristics of the RS-232-C Port	2
Character Transmission	2
Cabling for Your RS-232-C Device	3
Direct Connection to a Computer	5
Connection to Another Communication Module	6
Connection to a Modem	8
Choosing a Modem for Point-to-Point/Full-Duplex Applications	9
Using the 1785-KE in an Auto-Answer Application	11

Choosing a Modem for Multidrop/Half-Duplex Applications	12
Communicating Through the 1785-KE Module	1
Chapter Objectives	1
Application 1: Connecting a Computer to Data Highway Plus	1
Computer to PLC-5	2
PLC-2 Normal Unprotected Write	3
PLC-2 Normal Unprotected Read	4
PLC-3 Normal Unprotected Write (Word Range Write)	5
PLC-3 Normal Unprotected Read (Word Range Read)	6
Application 2:	
Communicating Between Two Data Highway Plus Networks	7
PLC-5 Write Commands	8
PLC-5 Read Commands	9
Program Verification	10
Application 3: Multidrop Applications With the 1785_KE Series B	11
Example 1: Master to Slave Communication	13
Example 2: Slave to Master Communication	16
PLC-2 Unprotected Write	16
PLC-2 Unprotected Read	17
Program Verification	18
Example 3: Slave to Slave Communication	18
PLC-2 Unprotected Write	19
Read Command	20
Program Verification	21
Polling More Than One PLC-5 on a Data Highway Plus	21
Using the Multidrop Expansion Digit	22
1785-KE Diagnostic Tools	1
Chapter Objectives	1
Using the LED Indicators	1
The 1785-KE Diagnostic Counters	3
What is a Diagnostic Counter?	3
How to Read Diagnostic Counters	3
1785-KE Data Highway Plus Diagnostic Counters	4
Specifications	1
Definitions of RS-232-C Handshaking Signals	1

Using a Series A 1785-KE Module	1
Appendix Objectives	1
Replacing a Series A Module with a Series B Module	1
Setting the Communication Option Switch	2
Switch Assembly SW-1: RS-232-C Link Features	3
Switch Assembly SW-2: For Future Use	4
Switch Assemblies SW-3 and SW: Node Number	5
Switch Assembly SW-5: Network Link Communication Rate	6
Switch Assembly SW-6: RS-232-C Communication Rate and Diagnostic Commands	6
Mounting the 1785-KE Module	7
Making Connections to the Series A 1785-KE	8
Interprocessor Addressing	1
Appendix Addressing	1
How to Address a PLC-5 From a PLC-2	1
Addressing a PLC-5 From a PLC-3	4
Communicating From a Computer to a PLC-5	5

Using This Manual

Chapter Objectives

After reading this chapter, you should know:

- if this manual contains the information you need
- where to locate information in this manual
- where to locate information on related products

Purpose of This Manual

This manual describes the 1785-KE Data Highway Plus RS-232-C Interface Module. It gives you procedures for:

- installing the 1785-KE
- troubleshooting your 1785-KE

For more information on programming and troubleshooting Data Highway Plus and Data Highway interface modules, refer to the Data Highway/Data Highway Plus Protocol and Command Set Reference Manual (publication 1770-6.5.16).

Who Should Read This Manual

You should read this manual before attempting to install or use the 1785-KE. We assume that you are already familiar with:

- RS-232-C standards and practices
- your RS-232-C device or modem
- Allen-Bradley Programmable Logic Controllers (PLCs)

Series B Enhancements

This manual describes both Series A and Series B versions of the 1785-KE module. Table 1.A lists the Series B enhancements to the module. These features were not available on the Series A version of the module. Where we describe these features later in the manual, we note that they are only available on the Series B version of the module. You can see the catalog number and the series level of the module on the name plate on the side of the module.

Table 1.A
Series B Enhancements

Feature	Benefit
Remote Addressing Capability (Full Duplex Operation)	Enhanced communications capability for applications involving point to point modem links.
Remote Addressing Capability (Half Duplex Operation)	Enhanced communications capability for applications involving multidrop modem links.

The Series B version of the 1785-K module uses different communication option switches and has a different front cover and Data Highway Plus connectors than the Series A version. Information on setting the Series A is included in Appendix C for reference.

Frequently Used Terms

In this manual, we use the following terms:

This Term:	Means:
Data Highway Plus	formerly Peer Communications Link (PCL)
link	a Data Highway or Data Highway Plus network
local node	node on local link
remote node	node on remote link

Precautionary Notes

In this manual, you will see:

- **WARNINGS** to tell you where you may be injured if you do not follow procedures properly
- **CAUTIONS** to tell where equipment may be damaged if you do not follow procedures properly
- **Important** notes that stress information that is critical to your understanding and use of the product

Related Products

The 1785-KE Data Highway Plus RS-232-C Interface Module is part of the Data Highway Plus product family. Related products include:

Product	Catalog Number:
Data Highway or Data Highway Plus/ Asynchronous (RS-232-C or RS-422-A) Interface Module	1770-KF2
Data Highway Plus to Data Highway 1785-KA Interface Module	1785-KA
Data Highway Plus PLC-2 Family Communication Adapter Module	1785-KA3
PLC-3 I/O Scanner Communication Adapter Module	1775-S5,-SR5
Industrial Terminal System	1784-T50
PLC-5 Family Programmable Controllers	Series 1785

Related publications

For more information on the 1785-KE and the Data Highway Plus network, refer to the following documents:

Publication:	Publication Number:
Data Highway Plus Overview Product Data	1785-2.6
Data Highway/Data Highway Plus Protocol and Command Set User's Manual	1770-6.5.16
Data Highway Cable Assembly and Installation Manual	1770-6.2.1

The publications in the table above are available from Allen-Bradley. Contact your local Allen-Bradley sales office for more information.

Overview of the 1785-KE and Data Highway Plus

Chapter Objectives

In this chapter, we give you an overview of the 1785-KE module and how it interfaces with a Data Highway Plus network.

What is the 1785-KE Module?

The 1785-KE module is a communication interface that links an intelligent RS-232-C (asynchronous) device to an Allen-Bradley Data Highway Plus network. The 1785-KE gives you a choice of **full duplex** (unpolled) or **half duplex** (polled) protocol on its asynchronous link.

Figure 2.1 shows the 1785-KE module's hardware features:

- diagnostic indicators
- connector for the Data Highway Plus
- connector for the T50 Industrial Terminal
- connector for an RS-232-C device

Figure 2.1
1785-KE Communication Interface Module

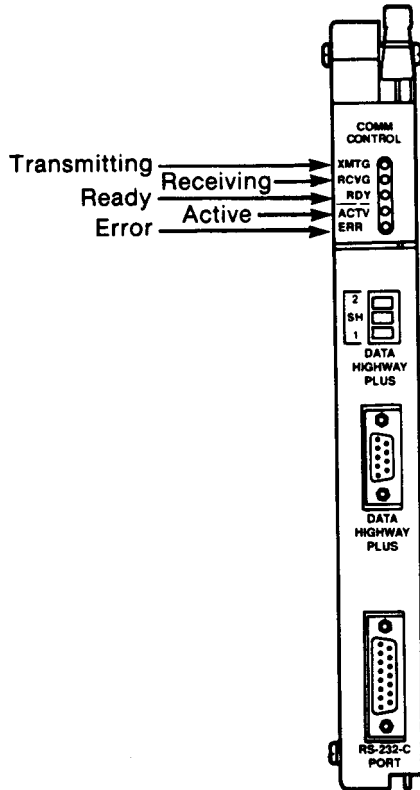

What is Data Highway Plus?

Data Highway Plus is a local area network (LAN) that allows peer-to-peer communication among up to 64 nodes. You use Data Highway Plus when you want to connect a small number of nodes on a common link.

Data Highway Plus provides easy re-configuration and expansion if you want to add more nodes later.

Typically, you would use Data Highway Plus to connect PLC-5s that need to communicate with each other frequently. For example, you would use Data Highway Plus to connect a small group of PLC-5s (approximately 10 nodes or less) involved in a single integrated process. Larger links, or those in looser configurations, could use a Data Highway as a common backbone network.

Communication on a Data Highway Plus involves:

- a physical link layer
- software layers

The Physical Link Layer

The physical link layer is a set of cables and interface modules that work together to provide a channel for communication between the various points, called **nodes**, on the physical link.

A Data Highway Plus node consists of an interface to Data Highway Plus, usually a module. (The PLC-5 processor has a Data Highway Plus connection built in, so it does not need a separate interface module.)

The Data Highway Plus cables consist of a trunkline that can be up to 10,000 feet long and droplines that can be up to 100 feet each.

You can use your Data Highway Plus to connect such nodes as:

- RS-232-C devices attached to a 1785-KE or a 1770-KF2
- Data Highway modules attached (via their RS-232-C port) to a 1785-KE or a 1770-KF2
- a PLC-3 or PLC-3/10 attached to a 1775-S5,-SR5
- a PLC-2 family device attached to a 1785-KA3
- PLC-5s (direct connection)
- a T50 industrial terminal
- a 1785-KA (connected to a Data Highway network)

Figure 2.2 illustrates a typical Data Highway Plus network.

Figure 2.2
 A Typical Data Highway Plus Configuration

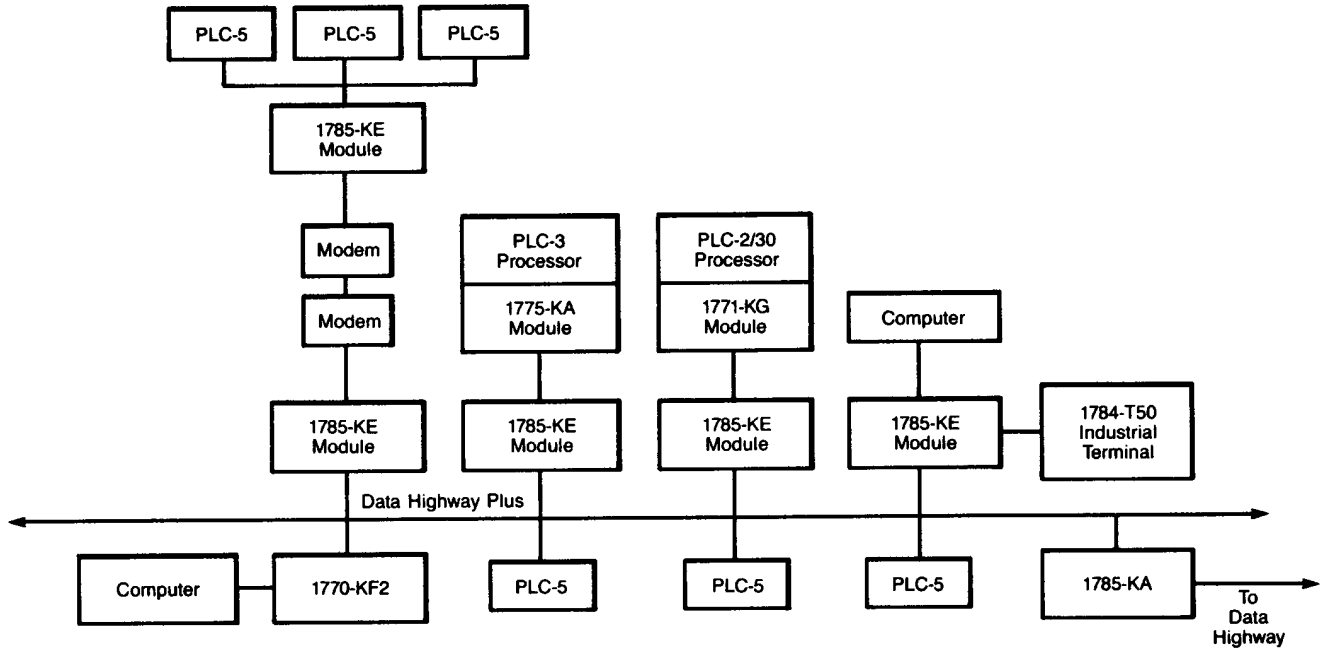

17036

Important: A computer connected to a 1785-KE module cannot access a node on a Data Highway through a 1785-KA module. Also, nodes on Data Highway cannot access a computer connected to a 1785-KE on Data Highway Plus.

The Software Layers

Both Data Highway Plus and the 1785-KE's RS-232 asynchronous link require two layers of software to enable communication to take place. The layers are defined as follows:

- Application layer -- controls and executes the actual tasks, or commands, specified in the communication between nodes.
- Data link layer -- controls the flow of communication over the physical link by establishing, maintaining, and releasing the communication channel between nodes.

The 1785-KE module automatically takes care of the data link layers on the Data Highway Plus network.

This means that your application programs at the PLCs and computers do not need to bother with inter-node protocol, handshaking, or control of the Data Highway Plus link.

You must program these layers, however, for the asynchronous link between your 1785-KE and its RS-232-C device. This programming allows your computer to communicate with the Data Highway Plus network, through the asynchronous link.

For more information on the commands, protocols, and diagnostics used on your Data Highway Plus network, refer to the Data Highway/Data Highway Plus Protocol and Command Set User's Manual (publication 1770-6.5.16). This manual contains the information you need to program the software layers for your computer and troubleshoot your network.

The Data Highway Plus Protocol

The Data Highway Plus link has a communication rate of 57,600 bits per second. The Data Highway Plus implements peer-to-peer communication with a token passing scheme to rotate link mastership among its stations. Since this method does not require polling, it is time efficient. The Data Highway Plus uses factory set timeouts to rebuild the token pass network if a token is lost because of a defective station. This timeout is not adjustable.

The RS-232-C Asynchronous Link Protocols

The 1785-KE's RS-232 asynchronous link has a selectable communication rate from 110 bits per second to 19,200 bits per second. It uses a selectable protocol of half-duplex (master-slave, polled) or full-duplex (peer-to-peer, unpolled).

You can select the half-duplex protocol for a multidrop or point-to-point communication link. You can select the full-duplex protocol only for a point-to-point communication link.

Full-Duplex Protocol

The full-duplex protocol conforms closely to ANSI X3.28, combining features of subcategories D1 (data transparency) and F1 (two-way simultaneous transmission with embedded responses).

You can use full-duplex protocol for a point-to-point link that allows two-way simultaneous transmission. It is relatively difficult to implement because it requires you to use interrupts and multi-tasking programming techniques. It is intended for high performance applications where you need to get the highest possible throughput from the available communication medium.

Half-Duplex Protocol

Half-duplex protocol serves as an alternate to full-duplex protocol. Half-duplex protocol is similar to full-duplex in most respects. Two major differences are:

- Half-duplex protocol provides for polling of slave stations.
- Half-duplex protocol does not allow embedded responses.

Half-duplex protocol is used for a link between one master and one or more slaves. You must use modems for this type of link (unless there is only one slave). The 1785-KE module has slave mode capability only. You must provide the master function through a computer, or the 1771-KGM module.

Half-duplex protocol provides a lower effective utilization of resources compared to full-duplex, but it is easier to implement. You should use half-duplex protocol if:

- you are using multidrop modems to connect multiple slave stations to a single master computer.
- you are using modems that have only half-duplex capability.
- you are willing to sacrifice data throughput in exchange for ease of implementation.

Delivery Order of Commands

If any node on a Data Highway Plus network initiates multiple commands (for example, the initiating node sets multiple bits at any time), the order in which those commands get executed at the remote node cannot be guaranteed. The initiating node, the network, and the receiving node execute commands based on network conditions, including but not limited to:

- nodes buffering commands
- retries due to noise on the network

If your application requires that commands be delivered in a specific order, your logic must control the initiation of one command at a time on the network and verify delivery before initiating additional commands. This verification is completed by:

- a done bit or an error bit in a PLC
- a reply message in a computer

A done bit or a successful reply should cause the next command to be initiated. If an error bit or a reply with non-zero status is returned, you must decide the appropriate action based on your application.

Applications

Three typical applications of the 1785-KE are discussed in this manual:

- connecting a computer or other intelligent device to Data Highway Plus via an RS-232-C point-to-point link (local mode, full- or half-duplex protocol option).
- connecting two Data Highway Plus networks together over a point-to-point modem link (remote mode, full-duplex protocol option).
- connecting a Data Highway Plus node (such as a PLC-5) as a slave on a multidrop link with a modem (remote mode, half-duplex slave protocol option).

These are discussed in more detail later in Chapter 5, “Communicating through the 1785-KE Module”. A short discussion of each application follows:

Figure 2.3 shows an example of using a 1785-KE to attach a computer or other intelligent RS-232-C device to Data Highway Plus. You attach the computer to Data Highway Plus using a point-to-point RS-232-C link. Figure 2.3 shows the following three options using:

- a short (50 feet or less) RS-232-C link
- the AB-longline RS-232-C option
- a point-to-point modem link

Refer to Chapter 4 for more information on these RS-232-C options.

Figure 2.3
Point-to-Links to a Data Highway Plus Network

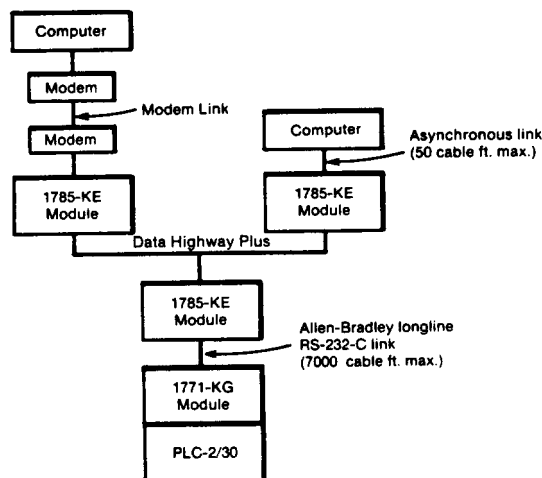

15221

You can use either full-duplex or half-duplex for the RS-232-C link.

Figure 2.4 shows an example of using a 1785-KE (series B) to connect two Data Highway Plus networks over a point-to-point modem link. You must set the 1785-KE for full-duplex protocol in this application.

Figure 2.4
Communication Between Two Remote Data Highway Plus Networks

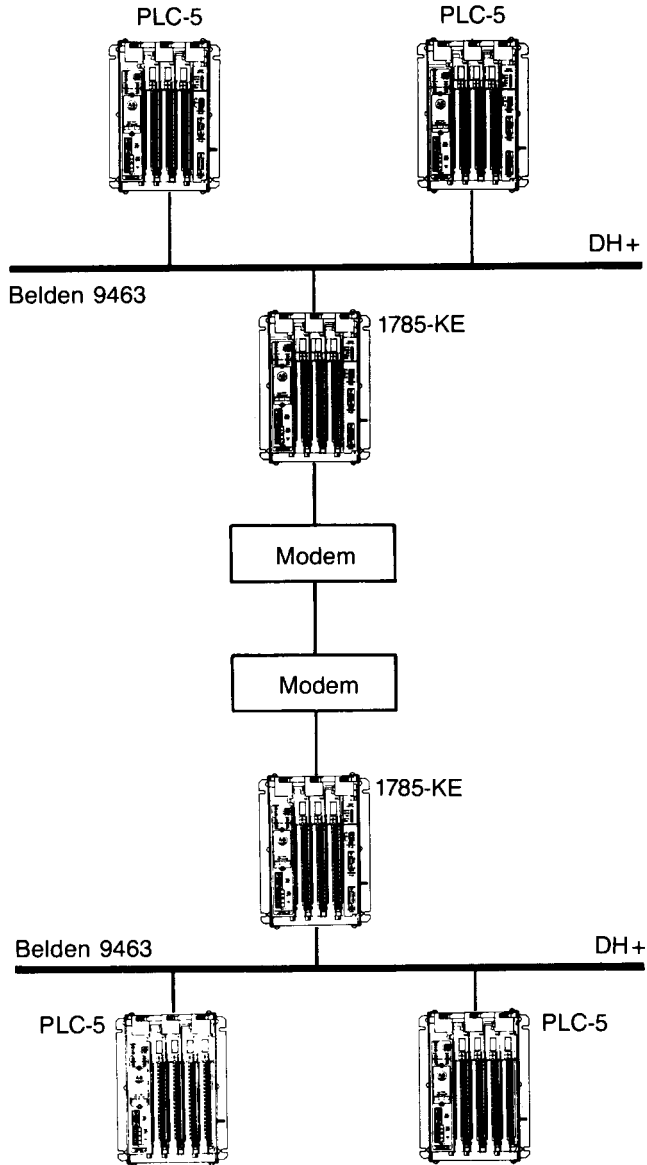

17037

Figure 2.5 shows an example of using the 1785-KE (series B) to connect a Data Highway Plus node (such as a PLC-5) to a multidrop network. The PLC-5 acts as a slave on the multidrop link. You must set the 1785-KE for half-duplex protocol and use modems.

Figure 2.5
Multidrop Networking Using the 1785-KE (Series B)

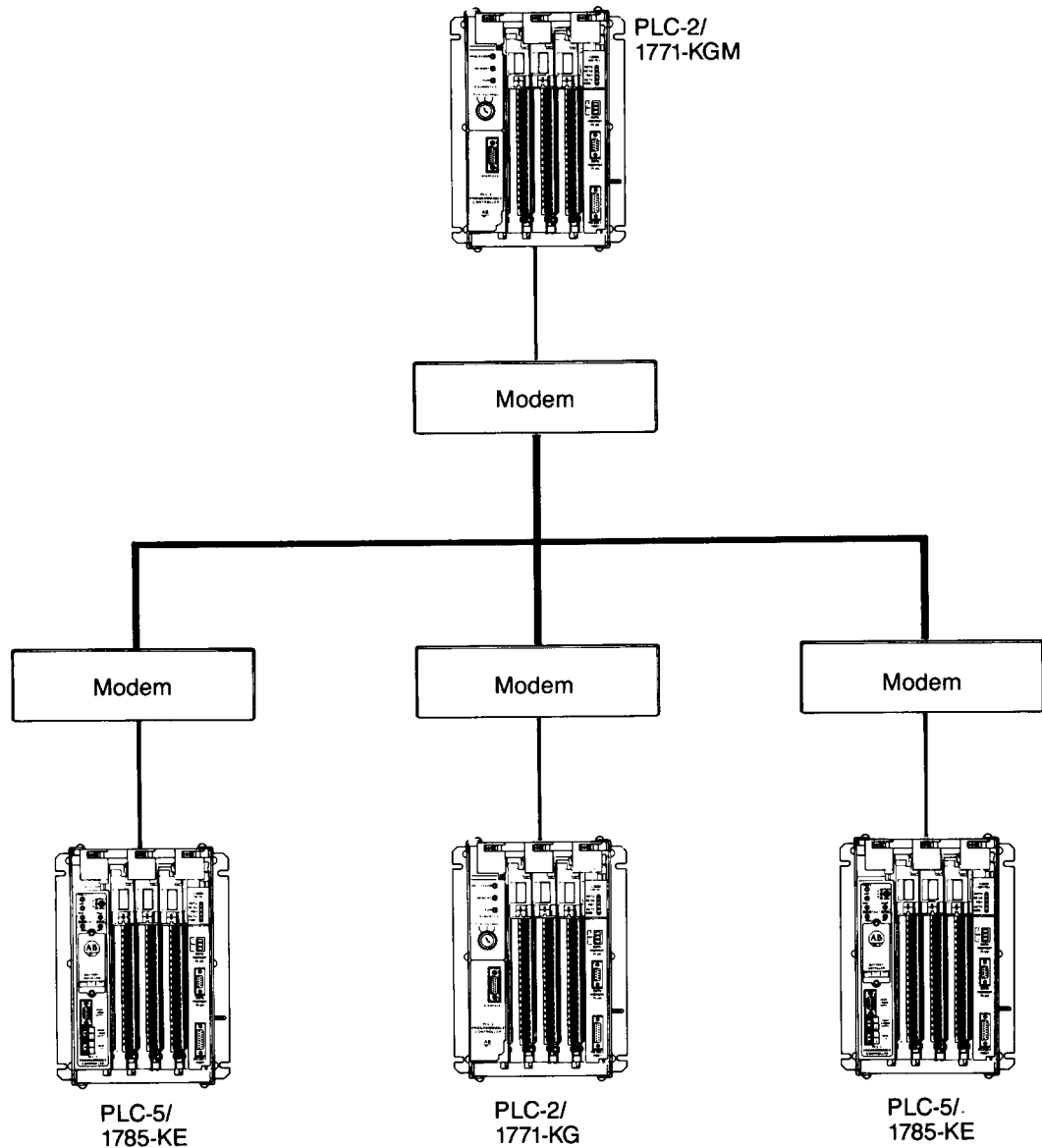

Installing the 1785-KE

Chapter Objectives

This chapter explains how to install the 1785-KE module. There are four parts to installation:

- setting the communication option switches
- mounting the module
- connecting the module to the Data Highway Plus link
- powering up your module

Refer to Chapter 4 for information on how to connect your RS-232-C device to the 1785-KE module.

Read the first two chapters of this manual carefully before attempting to install the 1785-KE.

Important: The Series B version of the 1785-KE module uses different communication option switches, has a different front cover, and has different Data Highway Plus connectors than the Series A version. This chapter describes the Series B version. Information on setting the Series A communication option switches and making connections to the Series A is included in Appendix C for reference.

Setting the Communication Option Switches

The 1785-KE module has 4 switch assemblies (figure 3.1) that enables you to select various communication options. The switch assemblies and their corresponding options are:

Select this Switch Assembly:	For this Communication Option:
SW-1	RS-232-C link features
SW-2	Node number
SW-3	-Data Highway Plus and RS-232-C link communication rates -Local/remote option
SW-4	Reserved

Figure 3.1
Location of the Switch Assemblies on the 1785-KE Module

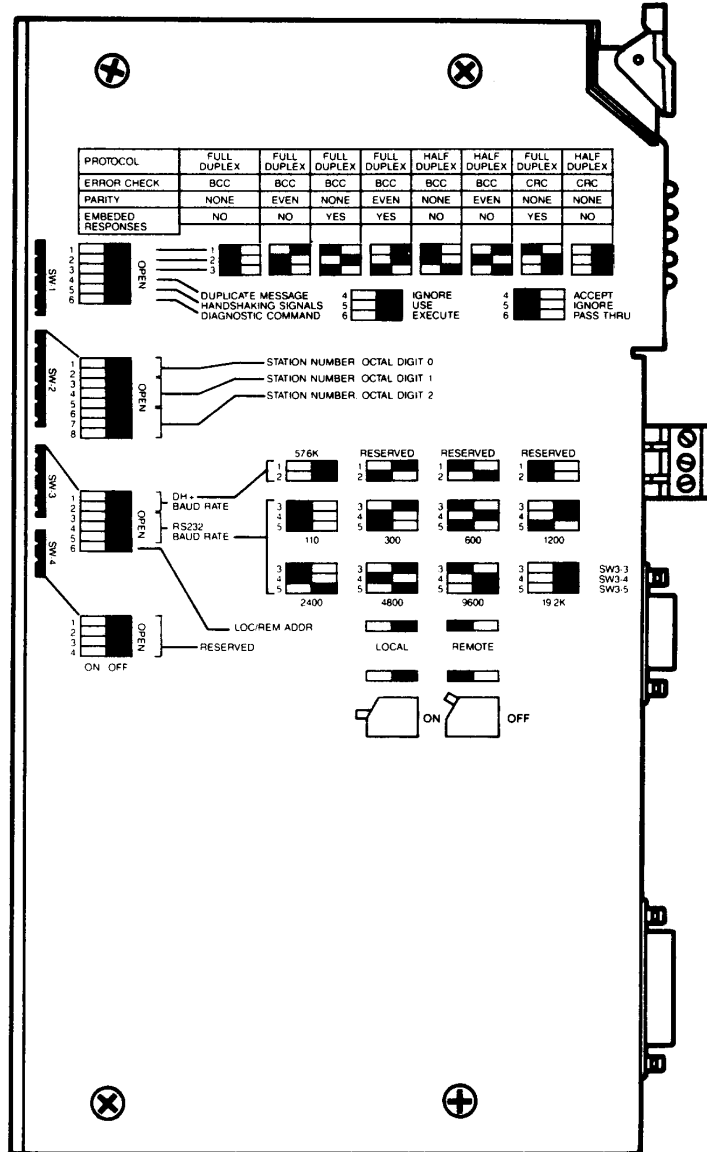

17039

Important: The 1785-KE Series B uses the convention DOWN (ON) = Binary 0, and UP (OFF) = Binary 1.

**Switch Assembly SW-1:
RS-232-C Link Features**

Figure 3.2 shows the 1785-KE (Series B) set for:

- full duplex
- BCC error checking
- even parity
- embedded responses enabled
- detect and ignore duplicate messages
- ignore handshaking
- execute diagnostic commands

Figure 3.2
The Switches on Switch Assembly SW-1

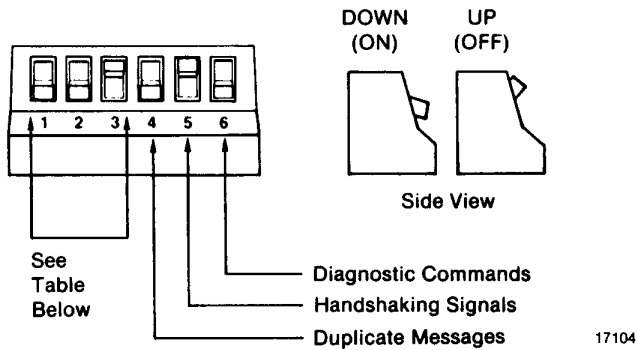

The following table shows you how to set switches 1, 2, and 3 for the module options you require.

If You Want to Select Protocol as:	With Error Check as:	With Parity as:	With Embedded Responses:	Set these SW-1 Switches:		
				1	2	3
full duplex	BCC	none	no	UP (OFF)	UP (OFF)	UP (OFF)
full duplex	BCC	even	no	DWN (ON)	UP (OFF)	UP (OFF)
full duplex	BCC	none	yes	UP (OFF)	DWN (ON)	UP (OFF)
full duplex	BCC	even	yes	DWN (ON)	DWN (ON)	UP (OFF)
full duplex	BCC	none	no	UP (OFF)	UP (OFF)	DWN (ON)
half duplex	BCC	even	no	DWN (OFF)	UP (ON)	DWN (ON)
full duplex	CRC	none	yes	UP (OFF)	DWN (ON)	DWN (ON)
half duplex	CRC	none	no	DWN (ON)	DWN (ON)	DWN (ON)

Switch 4 determines whether or not the RS-232-C port of the 1785-KE module can detect duplicate messages transmitted to it.

If You Want the Module to:	Set Switch 4:
detect and ignore duplicate messages	DOWN (ON)
accept all messages regardless of duplication	UP (OFF)

Switch 5 determines whether the RS-232-C port on the 1785-KE module uses and recognizes the following handshaking signals.

- data set ready (DSR)
- request to send (RTS)
- clear to send (CTS)
- data carrier detect (DCD)
- data terminal ready (DTR)

If You Want the Port to:	Set Switch 5:
use handshaking signals	DOWN (ON)
ignore handshaking signals	UP (OFF)

Important: If you select half-duplex, the 1785-KE uses handshaking signals even if switch 5 is set UP.

To set diagnostic commands, you use switch 6 on SW-1. Use the table below to set switch 6.

If you want your module to:	Set switch 6:
execute diagnostic commands	DOWN (ON)
pass through diagnostic commands	UP (OFF)

Switch Assembly SW-2: Data Highway Plus Node Address

Switch assembly SW-2 is for setting the Data Highway Plus node address of the 1785-KE (figure 3.3).

Figure 3.3
Setting Switch Assembly SW-2

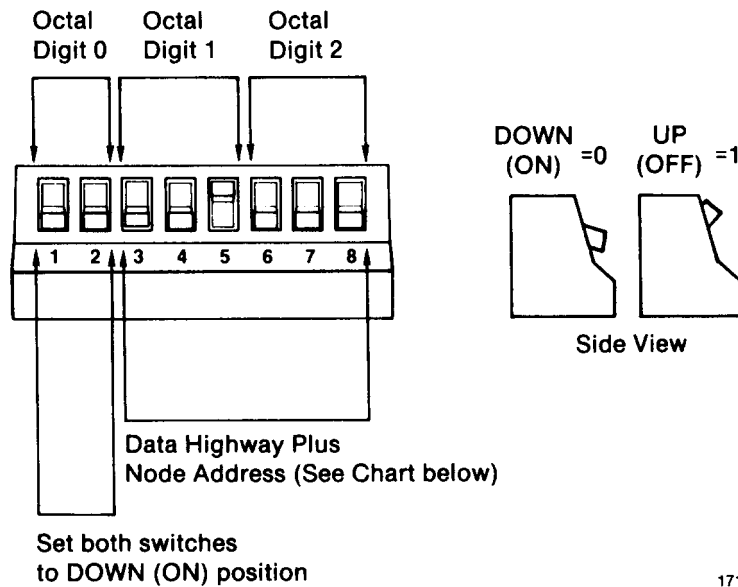

17105

As seen in the figure, SW-2 represents 3 octal digits; Octal Digit 0, Digit 1, and Digit 2.

Octal Digit 0

Octal Digit 0 (Switches 1 and 2) should be set to 0 (DWN DWN).

Octal Digits 1 and 2 (Data Highway Plus Node Address)

Octal Digits 1 and 2 are used to set a Data Highway Plus node address for the 1785-KE module. The node address is an encoded 2 digit octal number that identifies the 1785-KE module as a unique node on Data Highway Plus. Valid Data Highway Plus addresses for the 1785-KE module are 00 to 77 octal.

Octal Digit 1 (switches 3, 4, 5) is used to set the most significant octal digit (0-7) of the Data Highway Plus node address.

Octal Digit 2 (switches 6, 7, 8) is used to set the least significant octal digit (0-7) of the Data Highway Plus node address.

Figure 3.4 shows you how to set the Data Highway Plus node address with switch assembly SW-2.

Figure 3.4
Setting the Data Highway Plus Node Address with Switch Assembly SW-2

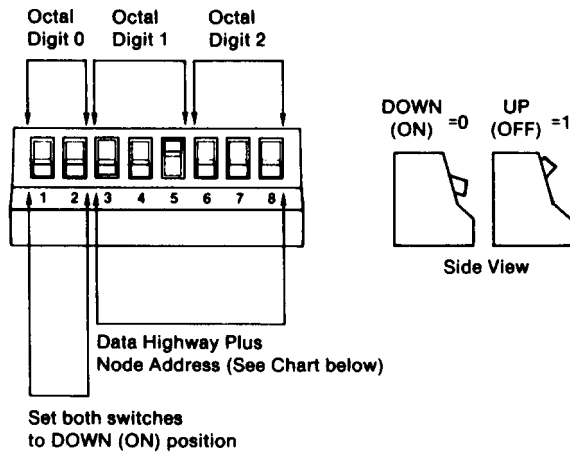

Octal Digit 1 (most significant)

To set Octal Digit 1 to:	Set switches 3 - 5		
	No.3	No.4	No.5
0	DWN (ON)	DWN (ON)	DWN (ON)
1	DWN (ON)	DWN (ON)	UP (OFF)
2	DWN (ON)	UP (OFF)	DWN (ON)
3	DWN (ON)	UP (OFF)	UP (OFF)
4	UP (OFF)	DWN (ON)	DWN (ON)
5	UP (OFF)	DWN (ON)	UP (OFF)
6	UP (OFF)	UP (OFF)	DWN (ON)
7	UP (OFF)	UP (OFF)	UP (OFF)

Octal Digit 2 (least significant)

To set Octal Digit 2 to:	Set switches 6 - 8		
	No.6	No.7	No.8
0	DWN (ON)	DWN (ON)	DWN (ON)
1	DWN (ON)	DWN (ON)	UP (OFF)
2	DWN (ON)	UP (OFF)	DWN (ON)
3	DWN (ON)	UP (OFF)	UP (OFF)
4	UP (OFF)	DWN (ON)	DWN (ON)
5	UP (OFF)	DWN (ON)	UP (OFF)
6	UP (OFF)	UP (OFF)	DWN (ON)
7	UP (OFF)	UP (OFF)	UP (OFF)

Important: The 1785-KE Series B uses the convention DWN (ON) = Binary 0, and UP (OFF) = Binary 1.

Figure 3.5 shows you how to set the node number 37 using Octal Digits 1 and 2 as follows:

Figure 3.5
Setting the Data Highway Plus Node Address 37

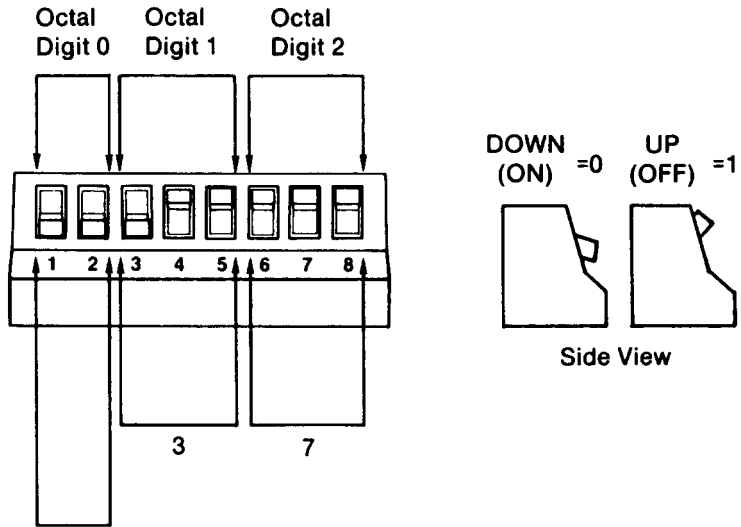

Set both switches
to DOWN (ON) position

17106

Octal Digit 0 (Most Significant Digit)

To set Octal Digit 1 to:	Set switches 3 - 5		
	No.3	No.4	No.5
3	DWN (ON)	UP (OFF)	UP (OFF)

Octal Digit 2 (Least Significant Digit)

To set Octal Digit 2 to:	Set switches 6 - 8		
	No.6	No.7	No.8
7	UP (OFF)	UP (OFF)	UP (OFF)

Important: The 1785-KE Series B uses the convention DOWN (ON) = Binary 0, and UP (OFF) = Binary 1.

**Switch Assembly SW-3:
Communication Rates and
Local/Remote Option**

Switch assembly SW-3 is for:

- setting the communication rate for the Data Highway Plus network and the RS-232-C link
- setting the module for local or remote operation

Figure 3.6
Setting Switch Assembly SW-3

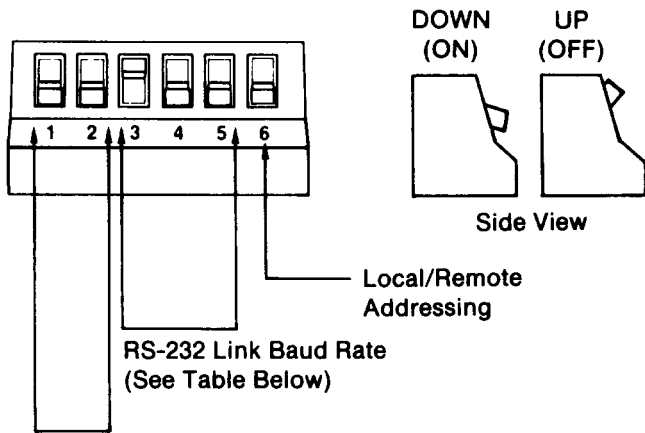

Data Highway Plus Baud Rate
(Set both switches to DOWN (ON) position)

17107

You use switches 1 and 2 to set the Data Highway Plus communication rate. Both switches must be DOWN for 57.6 Kbit communication rate.

You use switches 3, 4, and 5 to set the communication rate for the RS-232-C link between your device and the 1785-KE (figure 3.6). Use the following table to set these switches.

To Set this Rate in Bits Per Second:	Set These Switches:		
	3	4	5
110	UP (OFF)	UP (OFF)	UP (OFF)
300	DWN (ON)	UP (OFF)	UP (OFF)
600	UP (OFF)	DWN (ON)	UP (OFF)
1200	DWN (ON)	DWN (ON)	UP (OFF)
2400	UP (OFF)	UP (OFF)	DWN (ON)
4800	DWN (ON)	UP (OFF)	DWN (ON)
9600	UP (OFF)	DWN (ON)	DWN (ON)
19200	DWN (ON)	DWN (ON)	DWN (ON)

You use switch 6 of SW-3 to set local/remote operation. Use the table below as a guide to setting this switch:

If You are Using the 1785-KE to Connect:	Set Switch 6 to:
computer or other intelligent RS-232-C device to a Data Highway Plus network	local mode DOWN (ON)
Data Highway Plus node (such as a PLC-5) as a slave on a multidrop link, using a modem (fig. 2.5)	remote mode UP (OFF)
two Data Highway Plus networks over a point-to-point modem link (fig. 2.4)	remote mode UP (OFF)

Communications to a 1785-KE Series A is the same as that to a 1785-KE in local mode (i.e., when the 1785-KE Series B is in local mode, it functions the same as a 1785-KE Series A). As a result:

Important: If you are replacing a 1785-KE Series A with a 1785-KE Series B and desire Series A compatible operation, set the Local/Remote option switch to Local.

See Chapter 5 for more information on selecting this option.

Switch Assembly SW-4

Switch assembly SW-4 is reserved for future use. Set the switches in the UP position (figure 3.7).

Figure 3.7
Switch Assembly SW-4

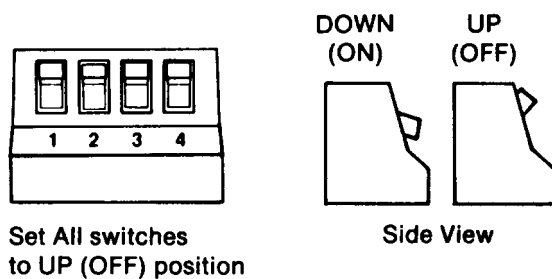

17108

Mounting the 1785-KE Module

The 1785-KE module mounts in an Allen-Bradley Bulletin 1771 I/O rack. If you are using a dropline/trunkline configuration, you must mount the 1785-KE module within 100 cable feet of the Data Highway Plus trunkline. When you are connecting the module directly to an RS-232-C device, you must mount the 1785-KE module within 50 cable feet of that device.

If the RS-232-C device is another Allen-Bradley communication module, you can mount the 1785-KE module up to 7,000 cable feet away from it by using the longline connection (discussed in Chapter 4). If you are using a modem link to connect the 1785-KE module to the RS-232-C device, then the module and the device may be as far apart as the modem link will allow.

To install a 1785-KE module in an Allen-Bradley Bulletin 1771 I/O rack, follow these steps:

1. Perform an orderly power down of the I/O rack and its controlling PLC processor.



WARNING: Remove system power before removing or installing your module in the 1771 I/O chassis. Failure to observe this warning could result in:

- damage to module circuitry
 - undesired operation and possible injury to personnel
-

2. Set the keying bands on the I/O rack slot. The 1785-KE is keyed to guard against installation in the wrong slot in your rack. Prior to installing your module in the rack, you may insert optional keying bands (provided with your 1771 I/O rack) on the backplane. If you elect to use keying bands, two are required. Insert the first between keying positions 6 and 8. Insert the second between keying positions 12 and 14.
3. Slide the 1785-KE module into one of the slots in the I/O rack. Snap down the latch on the top of the module slot to secure the module in the I/O rack.

Making Connections to the 1785-KE

The 1785-KE module has 3 connectors on its front edge (figure 3.8).

Figure 3.8
The Connectors on the 1785-KE

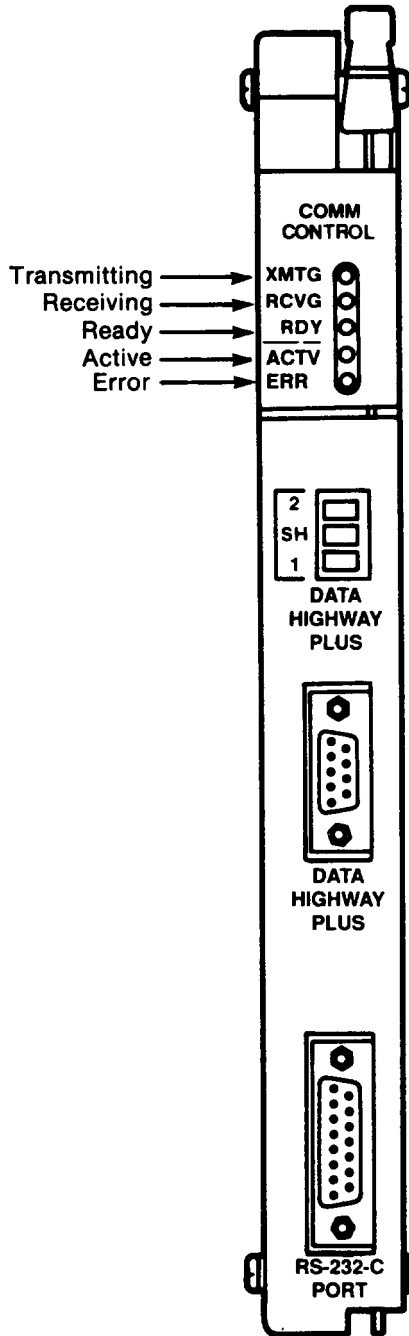

17045

To make connections to the 1785-KE, connect the 1770-CD cable to the screw terminals on the top 3-pin connector (figure 3.9).

If you are using a trunk drop configuration, for details on how to construct the dropline, refer to the Data Highway Cable Assembly and Installation Manual, publication 1770-6.2.1.

Figure 3.9
Connecting the 1785-KE to a Data Highway Plus Network

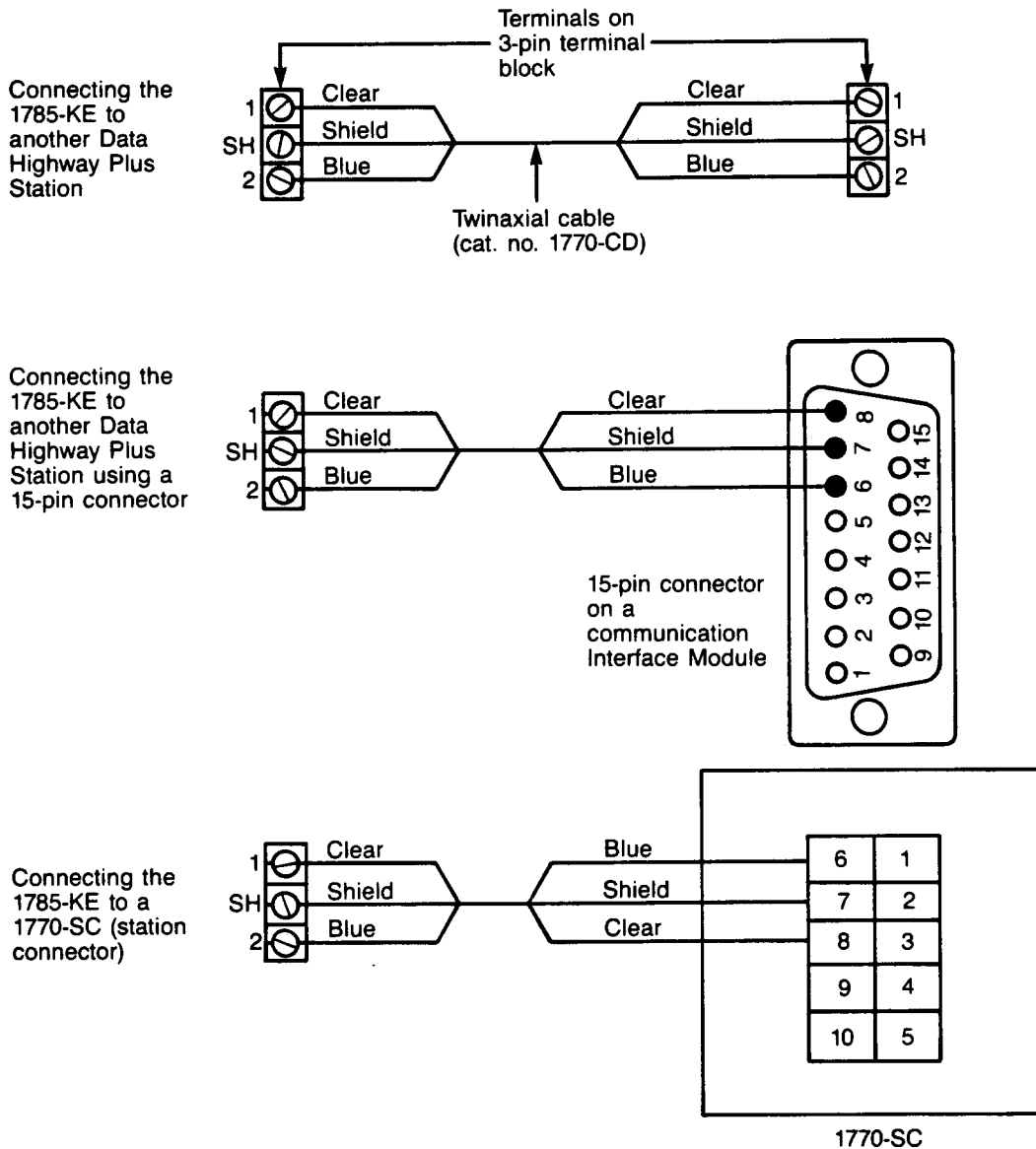

17046

If the 1785-KE is an end device in the Data Highway Plus Network, you must install a 150 ohm resistor on the 3-position terminal block or in the station connector (cat. no. 1770-SC).

Powering Up the 1785-KE Module

When you have successfully:

- set the switch assemblies on the 1785-KE to the setting suited to your application
- mounted your 1785-KE module in a 1771 I/O rack following the procedure earlier in this chapter
- connected your module to the Data Highway Plus
- connected your RS-232-C device to your 1785-KE (refer to Chapter 4)

you are ready to power up your 1785-KE module.

To power up your module, perform an orderly power up of the I/O rack and system PLC.

At power-up, the 1785-KE module runs tests to check the integrity of its internal memory, timers and firmware. Any failure causes the red ERR indicator (on the front panel) to flash.

Important: The test cycle during power up takes approximately 10 seconds. This delay is normal operation for the module.

For troubleshooting information, refer to the Data Highway/Data Highway Plus Protocol and Command Set Reference Manual (publication 1770-6.5.16).

Connecting Your RS-232-C Device to the 1785-KE

Chapter Objectives

In this chapter we give you guidelines for connecting your RS-232-C device to the 1785-KE.

For definitions of handshaking signals, refer to Appendix B.

The RS-232-C PORT Connector

You connect your RS-232-C device to the RS-232-C PORT connector (figure 4.1) on your 1785-KE module. The RS-232-C PORT connector, a female 15-pin D-shell, does not conform strictly to the RS-232-C standard, which specifies a 25-pin male connector. However, you can use an RS-232-C adapter cable (cat. no. 1770-CG or 1770-CP) to interface between this connector and a standard 25-pin connector.

Figure 4.1
The RS-232-C PORT Connector on the 1785-KE

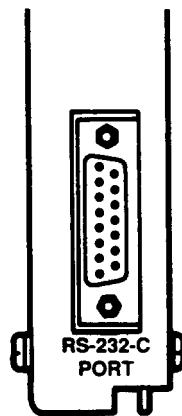

Electrical Characteristics of the RS-232-C Port

Input and output levels on the RS-232 port conform to the RS-232-C standard. The transmitter has increased capability to drive an isolated line that is up to 7,000 feet long. The length of this line determines the maximum communication rate on the RS-232-C link:

Line Length in Feet:	Maximum Communication Rate in Bits Per Second:
Up to 2,000	19,200
2,000 to 4,000	9,600
4,000 to 6,000	4,800
6,000 to 7,000	2,400

The receiver can sense the signals generated by a similar transmitter, and it is electrically isolated from all other circuitry on the module. It consists of an opto-isolater circuit with an input and return line at the RS-232-C port. All other signals on the RS-232-C port are driven and received by standard RS-232-C interface circuits, which have maximum drive capability of 50 feet.

Character Transmission

The 1785-KE module sends data serially over the RS-232-C interface, one 8-bit byte at a time. The transmission format conforms to ANSI X3.16, CCITT V.4, and ISO 1177, with the exception that the parity bit is retained while the data length is extended to eight bits.

The transmission format may be summarized as:

start bit
data bit 0
data bit 1
data bit 2
data bit 3
data bit 4
data bit 5
data bit 6
data bit 7
even parity bit (optional)
one stop bit

Cabling for Your RS-232-C Device

Cabling for the RS-232-C port of the 1785-KE module will vary, depending on your application. In general, the pinouts for this cabling are as follows:

Signal:	Mnemonic:	Standard RS-232 25-pin Connector:	1785-KE 15-pin Connector:
chassis/shield drain		1	1
transmitted data	TXD	2	2
received data	RXD	3	3
request to send	RTS	4	4
clear to send	CTS	5	5
data set ready	DSR	6	6
signal ground	GND	7	7
data carrier detect	DCD	8	8
data terminal ready	DTR	20	11
transmitted data return	TXDRET (longline only)		14
received data return	RXDRET (longline only)		13

For definitions of each signal, refer to Appendix B.

When communication option switch 5 of switch assembly SW-1 (handshaking enable/disable) is set DOWN, the RS-232-C port of the 1785-KE module can transmit or receive all of the above signals (refer to Chapter 3 for switch setting information). If this switch is UP, then the RS-232-C port uses only TXD, RXD, and GND (TXDRET and RXDRET for longlines).

Important: If you select half-duplex, the 1785-KE uses handshaking signals even if switch 5 is set UP.

Chapter 4

Connecting Your RS-232-C Device to the 1785-KE

If you are connecting a 1785-KE module to a device not manufactured by Allen-Bradley, then you must mount the module within 50 cable feet of that device. For such applications, the module's GND must be connected to the GND of the modem or computer. RXDRET must be jumpered to GND at the module. TXDRET should be left open. Note that this type of connection does not provide electrical isolation between the module and the connected device.

The following sections provide guidelines for cabling your 1785-KE to:

- a computer
- another Allen-Bradley communication module
- a modem

Direct Connection to a Computer

To connect the module directly to a computer, you can use a data terminal interface cable (cat. no. 1770-CG). This cable plugs into the RS-232-C PORT connector on the module and the RS-232-C compatible connector on the computer. Connect the cable shield at one end only.

The 1770-CG cable is 16.5 feet long. If you need a longer cable or a male/female adapter cable, you can construct your own according to the wiring diagram in Figure 4.2. Make sure that the cable length does not exceed 50 feet.

Figure 4.2
Wiring Diagram - RS-232-C PORT Connector to Computer

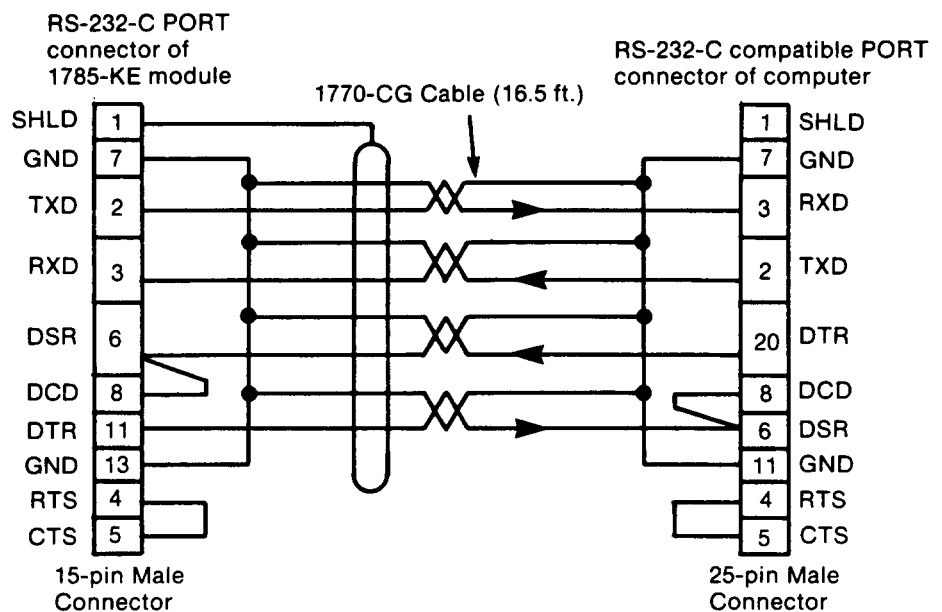

15233

This type of connection includes the DTR signal to allow each end to detect the loss of the other end's ability to communicate. If your computer does not provide the DTR signal, jumper pins 6 and 8 at the module to pin 11.

**Connection to Another
Communication Module**

You can connect the 1785-KE to another Data Highway interface module with a longline cable. This cable can be up to 7,000 feet long. However, remember that the cable length can limit the communication rate (refer to the section earlier in this chapter entitled Electrical Characteristics of the RS-232-C Port).

For information on how to construct a longline cable for connection to a:

- 1771-KG module, refer to figure [4.3](#)
- 1773-KA or 1775-KA module, refer to figure [4.4](#)

To construct the cable, use a male connector at each end. Use Belden 8723 or equivalent cable (available from Allen-Bradley under cat. no. 1778-CR). Connect the cable shield at one end only.

Figure 4.3
Connection to a 1771-KG Module

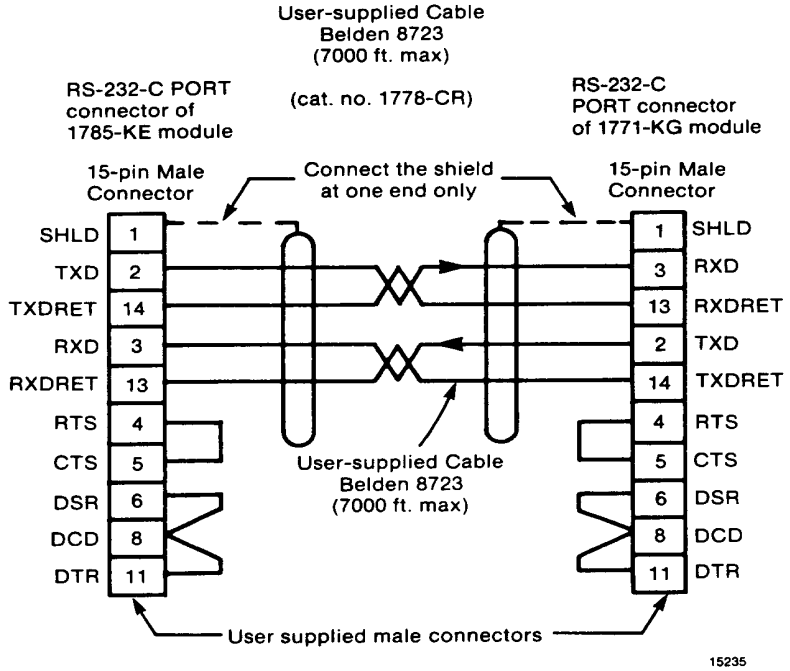
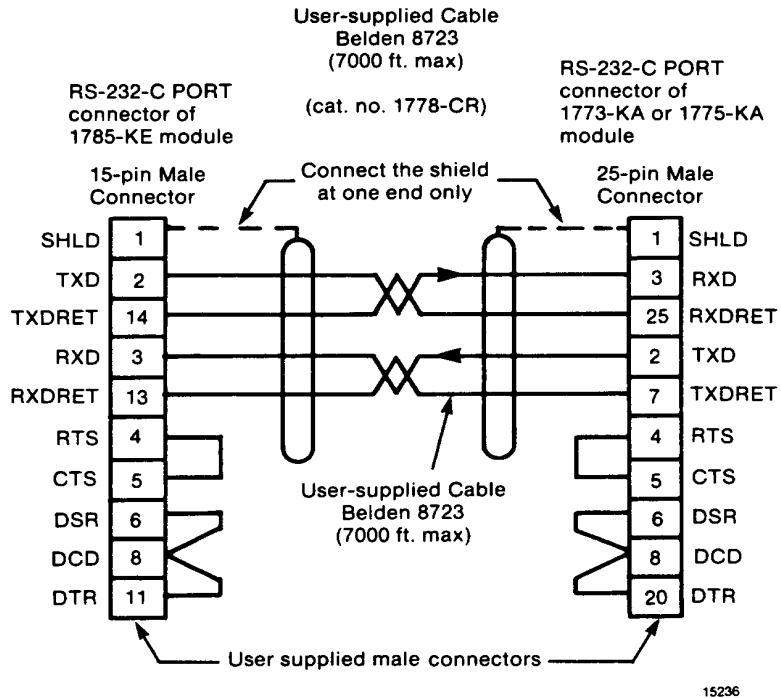

Figure 4.4
Connection to a 1773-KA or 1775-KA Module



Connection to a Modem

To connect the module to a modem, you can use the modem interface cable (cat. no. 1770-CP). This cable plugs into the RS-232-C PORT connector on the module and the RS-232-C compatible connector on the modem. Connect the cable shield at one end only.

The 1770-CP cable is 16.5 feet long. If you need a longer cable or a male/female adapter cable, you can construct your own according to the wiring diagram in Figure 4.5. Be sure that the cable length does not exceed the RS-232-C limit of 50 feet.

Figure 4.5
Wiring Diagram -- RS-232-C PORT Connector to a Modem

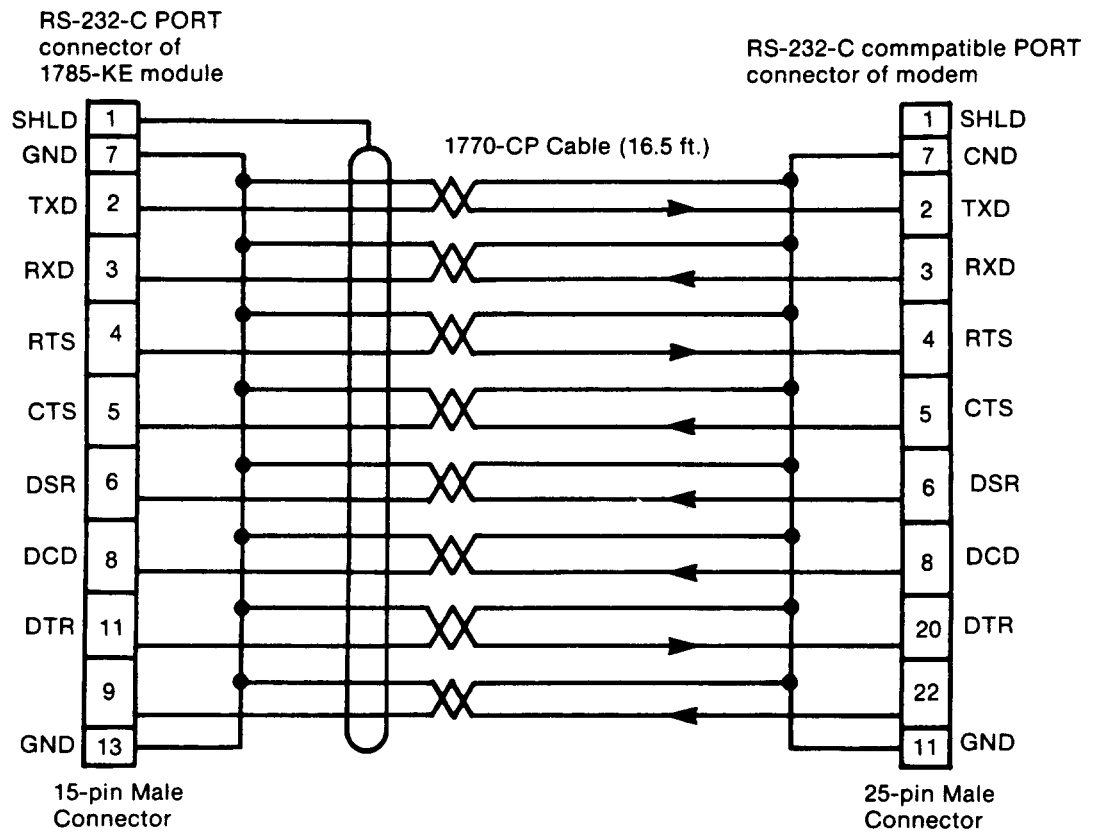

15234

Choosing a Modem for Point-to-Point/Full-Duplex Applications

This section provides guidelines for selecting the modems you use with the 1785-KE in point-to-point applications using full-duplex protocol.

The modem you use to interface to an Allen-Bradley RS-232-C communication module (using full-duplex protocol) must be capable of:

- supporting the standard RS-232-C handshaking described in Appendix B
- supporting the baud rate of your module
- operating on a full-duplex link
- interfacing to an asynchronous device
- operating in a “transparent” mode (data is passed over the link without being modified)

Note: If handshaking is enabled (via the SW-1 switch selection discussed in Chapter 3), and the DCD signal is lost for more than approximately 10 seconds, the 1785-KE follows the handshaking sequence described in the section “Using the 1785-KE in an Auto-Answer Application” later in this chapter. If your modem does not support this sequence, you can either disable handshaking, or with handshaking enabled, jumper DTR to DSR at the module to insure the module will recover after DCD is restored.

The 1785-KE can communicate via modems over either a:

- dedicated link (such as a leased phone line)
- dial-up link

The types of dial-up network modems that you can use are:

- **Manual:** These are typically acoustically coupled modems. The connection is established when human operators (at both ends) insert the telephone handsets into couplers to complete the connection.
- **DTE-controlled answer:** These unattended modems are directly connected to the phone lines. The module, serving as the data terminal equipment (DTE), controls the modem through the DTR, DSR, and DCD signals. The module incorporates timeouts and tests to properly operate these types of modems. See the section “Using the 1785-KE in an Auto-Answer Application” below for details.
- **Auto-answer:** These modems have self contained timeouts and tests, and can answer and hangup the phone automatically.

The module has no means of controlling an auto-dial modem, but it can be used in conjunction with a separate auto-dialer.

Using the 1785-KE in an Auto-Answer Application

The 1785-KE module continually asserts DTR when it is waiting for a call. Under this condition, a modem attached to the 1785-KE module will answer a call and assert DSR as soon as it detects ringing. The 1785-KE module does not monitor the RING indicator signal in the RS-232-C interface. Once it detects DSR, the module starts a timer (approximately 10 seconds) and waits for the DCD signal. When the module detects DCD, communication can start.

If the module does not detect DCD within the timeout, the module turns DTR off. This causes the modem to hang up and break the connection. When the hang-up is complete, the modem turns off DSR. This causes the module to reassert the DTR line and wait for another call. This feature protects access to the phone if someone calling a wrong number reaches the module.

After detecting DCD, the module continues to monitor the DCD line. If DCD goes off, the module restarts the timeout. If DCD is not restored within the timeout, the module initiates the hangup sequence. This feature allows the remote station to re-dial in the event that the connection is lost through a fault in the phone network.

This handshaking is necessary to guarantee access to the phone line. If you defeat this handshaking protocol by improper selection of your modem options or by jumpers at the connectors, the modem may still answer a call, but, if the connection is lost, the modem will not hang up. It will then be impossible for the remote station to re-establish the connection because it will get a busy signal.

You can connect the module to standard American dialup modems and some European modems.

Other European standards specify that the DTR signal will make the modem answer the phone, whether it is ringing or not. This causes the phone to always be “busy”. Since the 1785-KE module asserts the DTR signal while waiting for a call, you cannot use the 1785-KE with such modems.

Choosing a Modem for Multidrop/Half-Duplex Applications

This section provides guidelines for selecting the modems you use with the 1785-KE in multidrop applications using half-duplex protocol.

The multidrop link may either be a two-circuit system (master sends and slaves receive on one circuit, slaves send and master receives on the other), or a one-circuit system (master and slaves send and receive on the same circuit).

The half-duplex protocol is a polled protocol that only allows one node to transmit at a time. Because of this, the modems must operate in switched carrier mode (they only switch their carriers on when they transmit data). The RS-232-C handshaking lines are used to control the switching of the carrier for a message transmission as follows (figure 4.6):

- Request to Send (RTS) -- sent from the Allen-Bradley module to the modem to indicate the module has a message to send and wants a carrier to be established.
- Clear to Send (CTS) -- sent from the modem to the Allen-Bradley module to indicate that the carrier is established and that the module can send its message.
- Data Carrier Detect (DCD) -- sent from the modem to the Allen-Bradley module to indicate that a carrier has been detected and that a message is on the way. The module uses this signal to enable its receiver.

Figure 4.6
A Typical Packet Transmission Using RTS, CTS, and DCD

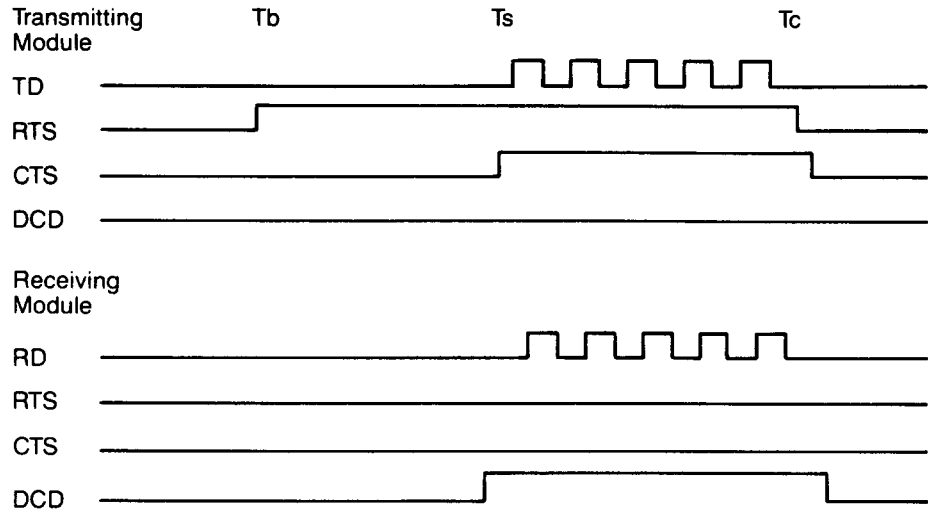

TD is the transmitted data
 RD is the received data
 Tb is the point at which the module has a packet buffered and ready to send.
 Ts is the point at which the packet is sent.
 Tc is the point at which the packet transmission is completed.

17047

The modem you use to interface to an Allen-Bradley RS-232-C communication module (using half-duplex protocol) must be capable of:

- supporting standard RS-232-C handshaking described in this section and in Appendix B
- supporting the baud rate of your module
- operating on a multidrop link
- operating in switched carrier mode under handshake control
- interfacing to an asynchronous device
- operating in a “transparent” mode (data is passed over the link without being modified)
- minimal RTS/CTS delay time, for optimum performance. This time is typically determined by the time it takes the modem to turn the carrier on.

Communicating Through the 1785-KE Module

Chapter Objectives

In this chapter, we discuss three typical applications of the 1785-KE module:

- connecting an intelligent RS-232-C device, such as a computer, to Data Highway Plus through a point-to-point RS-232-C link (local mode, full- or half-duplex protocol)
- connecting two Data Highway Plus networks together over a point-to-point modern link (remote mode, full-duplex protocol)
- connecting a Data Highway Plus node (such as a PLC-5) as a slave on a multidrop link through a modem (remote mode, half-duplex slave protocol)

Application 1: Connecting a Computer to Data Highway Plus

When you connect a computer or other intelligent RS-232-C device to Data Highway Plus (figure 5.1), you select the local mode option and either full- or half-duplex protocol. Refer to Chapter 3 for more information on setting the 1785-KE option switches.

Figure 5.1
Connecting a Computer to Data Highway Plus

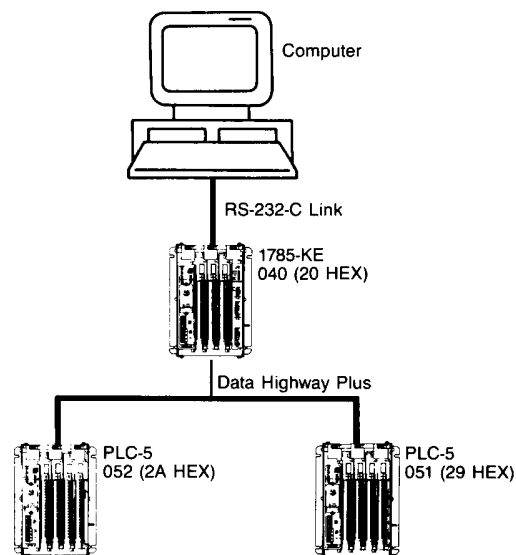

The computer is attached to the Data Highway Plus via the RS-232-C connection to the 1785-KE. In this configuration, the computer assumes the address of the 1785-KE on the Data Highway Plus, i.e., the computer and 1785-KE are addressed as a single node on the Data Highway Plus. As a result, messages sent from other nodes on the Data Highway Plus to the computer will use the address of the 1785-KE as the destination address. Messages sent from the computer to other nodes on the Data Highway Plus will use the address of the 1785-KE as the source node address.

The following example will use the system of figure 5.1 to illustrate commands initiated by the computer to PLC-5 051. The full duplex protocol is used in the examples.

You may wish to refer to Appendix D, “Interprocessor Addressing”, for further background information on communicating from a computer to a PLC-5.

Computer to PLC-5

In this example, we show the computer sending the following commands to the PLC-5:

- PLC-2 read and write commands
- PLC-3 read and write commands

We display the command formats that are sent over the RS-232-C link as they would appear on a line monitor placed between the computer and its 1785-KE Data Highway Plus module (all line monitor printouts are shown in hex). Full-duplex protocol is used.

In this example:

- computer (1785-KE) node address 040 (octal) = 020 (hex)
- PLC-5 node address: 051 (octal) = 029 (hex)

Important: If the computer sends a PLC-2 type command to the PLC-5, then the PLC-5 must create a PLC-2 compatibility file number 32 [computer node address 040 (octal) = 032 (decimal)]. This file must look like a PLC-2 data table to the computer.

If the computer sends a PLC-3 type command with a four-level extended address to the PLC-5, the command will be able to access any file in the PLC-5 data table.

For information on creating an RS-232-C asynchronous link driver for your computer, refer to the Data Highway/Data Highway Plus Protocol and Command Set Reference Manual (publication 1770-6.5.16).

PLC-2 Normal Unprotected Write

This example writes 4 words (8 bytes) of data to the PLC-5's PLC-2 compatibility file (file 32), word locations 20 through 23. The following paragraphs show line monitor examples for this command:

1. Computer sends command to the 1785-KE:

```
DLE STX DST SRC CMD STS TNS TNS ADR ADR -----DATA----- DLE ETX BCC
10 02 29 20 08 00 44 01 28 00 22 11 44 33 66 55 88 77 10 03 DE
```

2. 1785-KE responds to computer:

```
DLE ACK
10 06
```

3. 1785-KE sends command to the PLC-5:

The 1785-KE sends the command onto Data Highway Plus and the PLC-5 node at address 51 (octal).

4. PLC-5 sends the reply to the 1785-KE:

The PLC-5 receives the command, executes the command, formats a reply, and sends the reply back to the 1785-KE.

5. 1785-KE sends the PLC-5 reply back to the computer:

```
DLE STX DST SRC CMD STS TNS TNS DLE ETX BCC
10 02 20 29 48 00 44 01 10 03 2A
```

6. Computer responds to the 1785-KE.

```
DLE ACK
10 06
```

PLC-2 Normal Unprotected Read

This example reads the 4 words (8 bytes) of data that you sent with the PLC-2 Normal Unprotected Write command in the previous example. The following paragraphs show line monitor examples for this command:

1. Computer sends command to the 1785-KE:

```
DLE STX DST SRC CMD STS TNS TNS ADR ADR SIZE DLE ETX BCC
10 02 29 20 01 00 45 01 28 00 08 10 03 40
```

2. 1785-KE responds to computer:

```
DLE ACK
10 06
```

3. 1785-KE sends command to the PLC-5:

The 1785-KE sends the command onto Data Highway Plus and the PLC-5 node at address 51 (octal).

4. PLC-5 sends the reply to the 1785-KE:

The PLC-5 receives the command, executes the command, formats a reply, and sends the reply back to the 1785-KE.

5. 1785-KE sends the PLC-5 reply back to the computer:

```
DLE STX DST SRC CMD STS TNS TNS-----DATA----- DLE ETX BCC
10 02 20 29 41 00 45 01 22 11 44 33 66 55 88 77 10 03 CC
```

6. Computer responds to the 1785-KE.

```
DLE ACK
10 06
```

PLC-3 Normal Unprotected Write (Word Range Write)

This example writes 4 words (8 bytes) of data to the PLC-5 address 51 (octal) integer file 10, word locations 15 through 18. When you send a PLC-3 command to a PLC-5, the command can only have a four-level address. In this example, the address is in logical binary form. The following paragraphs show line monitor examples for this command:

1. Computer sends command to the 1785-KE:

```
DLE STX DST SRC CMD STS TNS TNS FNC PO PO TT TT |-----ADDRESS-----| |-----DATA-----|DLE ETX BCC
10 02 29 20 0F 00 46 01 00 00 00 04 00 0F 00 0A 0F 00 22 11 44 33 66 55 88 77 10 03 D1
```

2. 1785-KE responds to computer:

```
DLE ACK
10 06
```

3. 1785-KE sends command to the PLC-5:

The 1785-KE sends the command onto Data Highway Plus and the PLC-5 node at address 51 (octal).

4. PLC-5 sends the reply to the 1785-KE:

The PLC-5 receives the command, executes the command, formats a reply, and sends the reply back to the 1785-KE.

5. 1785-KE sends the PLC-5 reply back to the computer:

```
DLE STX DST SRC CMD STS TNS TNS DLE ETX BCC
10 02 20 29 4F 00 46 01 10 03 21
```

6. Computer responds to the 1785-KE.

```
DLE ACK
10 D6
```

PLC-3 Normal Unprotected Read (Word Range Read)

This example reads the 4 words (8 bytes) of data that you sent with the PLC-3 Word Range Write command in the previous example. When you send a PLC-3 command to a PLC-5, the command can only have a four-level address. In this example, the address is in logical ASCII form. The following paragraphs show line monitor examples for this command:

1. Computer sends command to the 1785-KE:

```

-----ADDRESS-----
DLE STX DST SRC CMDSTS TNS TNS FNC PO PO TT TT NL $ N 1 0 : 1 5 NL SIZE DLE ETX BCC
10 02 29 20 0F 00 47 01 01 00 00 04 00 00 24 4E 31 30 3A 31 35 00 08 10 03 E0

```

2. 1785-KE responds to computer:

```

DLE ACK
10 06

```

3. 1785-KE sends command to the PLC-5:

The 1785-KE sends the command onto Data Highway Plus and the PLC-5 node at address 51 (octal).

4. PLC-5 sends the reply to the 1785-KE:

The PLC-5 receives the command, executes the command, formats a reply, and sends the reply back to the 1785-KE.

5. 1785-KE sends the PLC-5 reply back to the computer:

```

DLE STX DST SRC CMD STS TNS TNS-----DATA----- DLE ETX BCC
10 02 20 29 4F 00 47 01 22 11 44 33 66 55 88 77 10 03 BC

```

6. Computer responds to the 1785-KE.

```

OLE ACK
10 06

```

**Application 2:
Communicating Between Two
Data Highway Plus Networks**

Figure 5.2 shows application involving communication between two Data Highway Plus networks through a full-duplex link between two Series B 1785-KE modules.

Figure 5.2
Connecting Two Data Highway Plus Networks

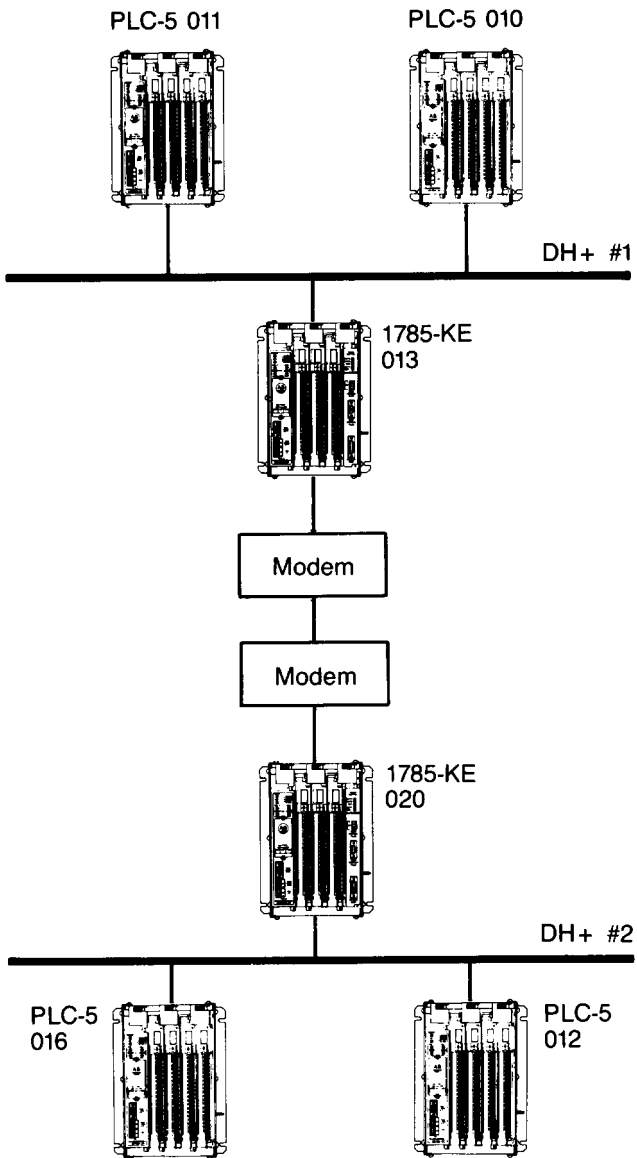

17049

When using a 1785-KE in this application, it should be set for Remote mode by setting the Remote/Local option switch (refer to Chapter 3).

When in Remote mode, the Series B 1785-KE module allows any PLC on one of the Data Highway Plus networks to talk to any PLC on the other Data Highway Plus network. This is made possible because the Series B module supports the Data Highway Plus remote addressing capability.

With remote addressing, the local 1785-KE (node address 013 on Data Highway Plus #1) can be addressed separately from the final destination PLC-5 (node address 012 on Data Highway #2). There are no additional restrictions on what the addresses can be when using the Series B 1785-KE to connect two Data Highway Plus networks.

In the following examples, we send PLC-5 read and write commands from a PLC-5 on Data Highway Plus #1 (node address 010) to a PLC-5 on Data Highway Plus #2 (node address 012).

PLC-5 Write Commands

This example message instruction writes eight words from the local PLC-5 (node 010) integer file 7, word locations 0 through 7, to the remote PLC-5 (node 012) integer file 7, word locations 0 to 7.

Program a message (MSG) instruction with the parameters shown below. Also, you must set up the message instruction for continuous mode by toggling bit N 10:20/11 to ON.

MESSAGE INSTRUCTION DATA MONITOR FOR CONTROL BLOCK N10:20

Read/Write:	WRITE	ignore if timed-out:	0 TO
PLC-5 Data Table Address:	N7:0	to be retried:	0 NR
Size in Elements:	8	awaiting execution:	0 EW
Local/Remote:	REMOTE	continuous:	1 CO
Remote Station:	012	error:	0 ER
Link ID	00	message done:	0 DN
Remote Link Type:	DATA HIGHWAY	message transmitting:	1 ST
Local Node Address:	13	message enabled:	1 EN
Processor Type:	PLC-5		
Destination Data Table Address:	N7:0	control bit addr:	N10:20/11
ERROR CODE: 0			

Press a key for desired function, or <ESC> or <RETURN> to exit monitor.

```
[
RUN   no forces      decimal data    decimal addr    PLC-5    Addr 10
      SIZE IN
      ELEMNTS
      F3              TOGGLE
                        BIT
                        F9
```

PLC-5 Read Commands

This example message instruction reads the eight words that were written to the remote PLC-5 (node 012) in the last example. The instruction stores these words in the integer file 7, word locations 10 through 17, of the local PLC-5 (node 010).

Program a message (MSG) instruction with the parameters shown below. Also, you must set up the message instruction for continuous mode by toggling bit N 10:0/11 to ON.

MESSAGE INSTRUCTION DATA MONITOR FOR CONTROL BLOCK N10:0

Read/Write:	READ	ignore if timed-out:	0 TO
PLC-5 Data Table Address:	N7:0	to be retried:	0 NR
Size in Elements:	8	awaiting execution:	0 EW
Local/Remote:	REMOTE	continuous:	1 CO
Remote Station:	012	error:	0 ER
Link ID	00	message done:	0 DN
Remote Link Type:	DATA HIGHWAY	message transmitting:	1 ST
Local Node Address:	13	message enabled:	1 EN
Processor Type:	PLC-5		
Destination Data Table Address:	N7:0	control bit addr:	N10:0/8

ERROR CODE: 0

Press a key for desired function, or <ESC> or <RETURN> to exit monitor.

```
[
RUN   no forces      decimal data    decimal addr    PLC-5    Addr 10
      SIZE IN
      ELEMNTS
      F3              BIT
                        F9
```

Program Verification

To verify that the example programs above are executing properly, follow these steps:

1. Look at the local PLC-5 (node 10 octal) file contents of integer file 7 by typing:
`<DISPLAY MONITOR> N7:0`
2. Change any value in word locations 0 through 7 in this file.
3. The values appearing in word locations 10 through 17 should be the same as the values in word locations 0 through 7.

Important: These PLC-5 to PLC-5 examples are for testing only. Toggling the continuous bit to ON generates high network traffic which, in most cases, is not necessary.

Application 3: Multidrop
Applications With the
1785_KE Series B

This section focuses on examples that use a 1771-KGM PLC-2 master which interfaces over an RS-232-C multidrop to PLC-5s used as slaves. If you are writing your own master driver or need more information on Allen-Bradley half-duplex protocol, refer to the Data Highway/Data Highway Plus Protocol and Command Set Reference Manual (publication 1770-6.5.16).

The examples in this section discuss message transfers as they occur with a PLC-5 using a 1785-KE Series B.

The 1785-KE acts as a slave on the multidrop and listens for messages addressed to a PLC-5 on its Data Highway Plus link. Thus, the master can send a message addressed directly to a PLC-5 and the 1785-KE will hear the message and pass it through. Therefore, you can use the same network addressing for PLC5/1785-KE slave nodes as for PLC-2/1771-KG slave nodes.

Figure 5.3 below will be used for the examples of this section. Note that a PLC-2/1771-KG (#012) is shown as a slave in the figure to illustrate the fact that the 1785-KE Series B allows both PLC-5's and PLC-2's to be addressed identically on the multidrop.

Figure 5.3
Using the 1785-KE Series B on a Multidrop

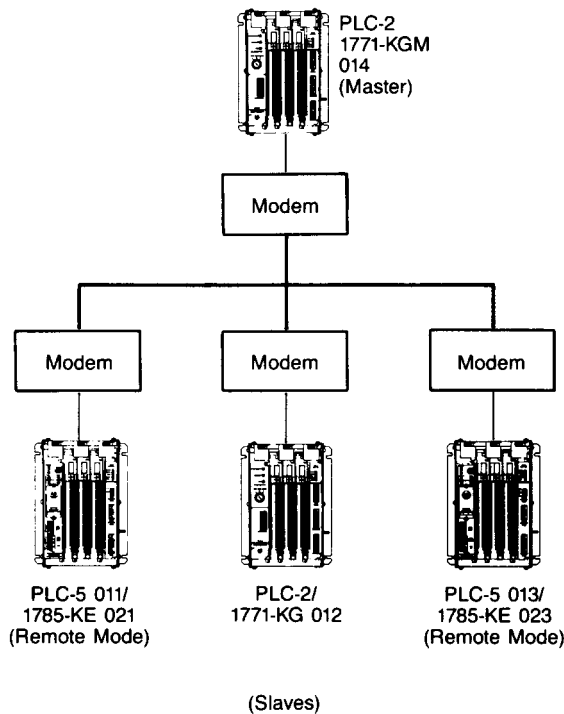

Note: When using the 1785-KE in this application, you must set each slave 1785-KE to Remote Mode by correctly setting the Local/Remote Option switch (see Chapter 3 for details).

You may wish to refer to Appendix D “Interprocessor Addressing” for more background information on addressing PLC-5’s from PLC-2’s.

Setting the 1785-KE’s Node Address

When used in a RS-232 multidrop application, the 1785-KE has each of the following:

- a Data Highway Plus address on the Data Highway Plus link
- a slave node address on the master-slave multidrop network

A single 1785-KE node address, used on both links, is selected by setting the appropriate switches on Switch Assembly SW-2 (see Chapter 3 for details on setting option switches).

The valid range of slave addresses on the multidrop network is 001-376 octal (010-077 and 110-376 octal when a 1771-KGM is used as the master). The valid range of addresses on Data Highway Plus is 00-77 octal.

Figure 5.4 below shows Switch Assembly SW-2

Figure 5.4

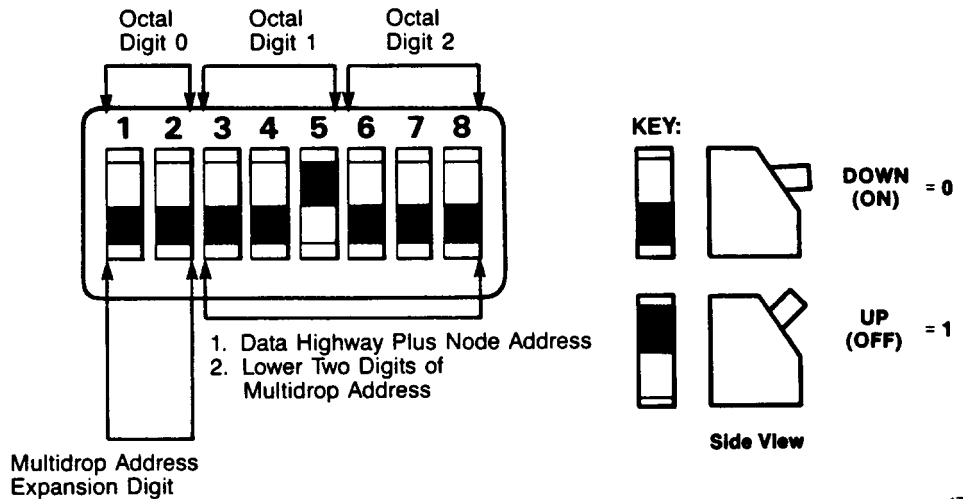

17051

Note from the figure that three octal digits are available: Octal Digit 0, Octal Digit 1, and Octal Digit 2.

Use Octal Digits 1 and 2 to set the 1785-KE's Data Highway Plus address from 00-77. These digits also set the lower two digits of the 1785-KE's address on the multidrop network.

Octal Digit 0 is an multidrop address expansion digit. It sets the most significant (highest) digit of the 1785-KE multidrop address. If your multidrop network only requires addresses 000-077 octal, you can set this digit to 00 (switch position DOWN DOWN). If you need to use addresses higher than 000-077 you will need to set this digit to 1 2 or 3. **See Using the Multidrop Address Expansion Digit** later in this chapter for more information on setting this digit.

Example 1: Master to Slave Communication

In this example, we send a message from the master (1771-KGM/PLC-2) at multidrop address 014 (octal), through the 1785-KE at address 021 (octal), to the PLC-5 with Data Highway Plus address 011 (octal).

The master sends the message to the PLC-5 address 011 (octal). The 1785-KE recognizes the address as one of the addresses on the Data Highway Plus link and passes the message through to address 011. The PLC-5 executes the command, processes a reply to the master, and returns the reply to the 1785-KE. Later, when the master polls for address 011, the 1785-KE returns the response from address 011.

In this communication, the 1785-KE is transparent to the master. The master is polling and sending messages only to the PLC-5 at address 011.

The following example shows the PLC-2 program to send a command from the PLC-2/1771-KGM master at address 014 (octal), through the 1785-KE, to the PLC-5 at Data Highway Plus address 011 (octal).

Important: Since the PLC-5 is communicating with a PLC-2, the PLC-5 must have a file set up to look like a PLC-2 data table. The PLC-5 file must be the decimal equivalent of the PLC-2/1771-KGM node address. Since the PLC-2/1771-KGM is at address 014 (octal), the PLC-5 must create file 012 ($014_8 = 012_{10}$) to communicate with the PLC-2.

PLC-2 Program Example

```

(1)      014  077  030                                027
      ----[G]---[G]---[G]----- (L)-----
                                           07

(2)      014  011  014                                027
      ---|/|---[G]---[G]----- ( )-----
           00                                           07

(3)      030  011  010  040  043                    027
      ---| |---| |---[G]---[G]---[G]----- ( )-----
           10   03                                           07

(4)      032  011  010  044  047                    027
      ---| |---| |---[G]---[G]---[G]----- ( )-----
           10   01                                           07

(5)      ----- (U)-----
                                           07

(6)      030  031  031                                030
      ---|/|---|/|---|/|----- ( )-----
           00   00   10                                           10

(7)      032  033  033                                032
      ---|/|---|/|---|/|----- ( )-----
           00   00   10                                           10

(8)      040                                           040
      ---|/|----- (TON)-----
           15                                           1.0
                                           PRE 999

(9)      041                                           041
      ---|/|----- (TON)-----
           15                                           1.0
                                           PRE 999

(10)     042                                           042
      ---|/|----- (TON)-----
           15                                           1.0
                                           PRE 999

(11)     043                                           043
      ---|/|----- (TON)-----
           15                                           1.0
                                           PRE 999

(12)     040  041  042  043                            050
      ----[G]---[G]---[G]---[G]----- (PUT)-----

(13)     044  045  046  047                            050
      ----[G]---[G]---[G]---[G]----- (PUT)-----

```

Rungs 8 through 11 are timer values to write to and then read from the PLC-5.

The following table summarizes the purpose of each rung in the example. For more information on 1771-KGM master programming, refer to the 1771-KGM User's Manual (publication 1771-6.5.39).

Rung:	What It Does:
1	communication one header rung -- the timeout preset code (the third GET statement) may need to be increased depending on your RS-232-C link characteristics.
2	configuration rung -- defines the nodes to be polled by the 1771-KGM. The 1771-KGM's address (014) must be included in the polling range. Note that the PLC-5's addresses are used in the polling range. (The 1785-KE's are transparent to the 1771-KGM and are not included in the polling range).
3	command rung -- normal PLC-2 Unprotected Write to PLC-5 node 011 (octal). The values in the timer accumulators 040 through 043 (octal) will be written into PLC-5 file 12 (decimal) element locations 8 through 11 (decimal).
4	command rung -- normal PLC-2 Unprotected Read to PLC-5 node 11 (octal). The values from the timer accumulators that were written to the PLC-5 file 012 (decimal) element locations 8 through 11 (decimal) will be read into word locations 044 through 047 (octal) in the PLC-2.
5	communication zone delimiter rung
6	This rung continuously cycles the command start bit for the normal Unprotected Write command.
7	This rung continuously cycles the command start bit for the normal Unprotected Read command.
8	timer 040 (octal)
9	timer 041 (octal)
10	timer 042 (octal)
11	timer 043 (octal)
12	This rung displays the four timer accumulator values that are written to the PLC-5.
13	This rung displays the four timer accumulator values that are read from the PLC-5.

To verify that the PLC-2 test program is executing properly, check the timer accumulator values in rungs 11 and 12. You should see the timer values in word locations 040 through 043 (octal) appear in word locations 044 through 047 (octal).

**Example 2: Slave to Master
Communication**

In this example, we send a message from the PLC-5 with Data Highway Plus address 011 (octal), through the 1785-KE at address 021 (octal), to the master (1771-KGM/PLC-2) at multidrop address 014 (octal).

In this case, the PLC-5 sends the command to:

- local destination: address 021
- remote destination: address 014

The command remains in the 1785-KE (address 021) buffer until the master polls address 011. The 1785-KE recognizes address 011 as a PLC-5 on its Data Highway Plus link and sends the command to the master. When the master finishes processing the reply, it sends it to the PLC-5 through the 1785-KE. The 1785-KE is transparent to the master.

The following examples show the T50 message instructions necessary to send PLC-2 Unprotected Read and Unprotected Write commands from the PLC-5 (address 011 octal) to the master (address 014 octal) through the 1785-KE.

PLC-2 Unprotected Write

This example writes eight words from integer file 7, word locations 0 through 7, to the PLC-2/1771-KGM master node (014 octal), data table words 050 through 057 (octal).

Program a message (MSG) instruction with the parameters shown below. Also, you must set up the message instruction for continuous mode by toggling N30:0/11 to ON.

MESSAGE INSTRUCTION DATA MONITOR FOR CONTROL BLOCK N30:0

Read/Write:	WRITE	ignore if timed-out:	0 TO
PLC-5 Data Table Address:	N7:0	to be retried:	0 NR
Size in Elements:	8	awaiting execution:	0 EW
Local/Remote:	REMOTE	continuous:	1 CO
Remote Station:	014	error:	0 ER
Link ID	00	message done:	0 DN
Remote Link Type:	DATA HIGHWAY	message transmitting:	1 ST
Local Node Address:	21	message enabled:	1 EN
Processor Type:	PLC-2		
Destination Data Table Address:	050	control bit addr:	N30:0/8
ERROR CODE: 0			

Press a key for desired function, or <ESC> or <RETURN> to exit monitor.

```
[
RUN   no forces      decimal data    decimal addr    PLC-5    Addr 11
      SIZE IN          TOGGLE
      ELEMNTS         BIT
      F3              F9
```

PLC-2 Unprotected Read

This example reads the eight words that were written to the PLC-2 data table with the last example. This example stores the data in integer file 7, word locations 10 to 17.

Program a message (MSG) instruction with the parameters shown below. Also, you must set up the message instruction for continuous mode by toggling bit N30:20/11 to ON.

MESSAGE INSTRUCTION DATA MONITOR FOR CONTROL BLOCK N30:20

Read/Write:	READ	ignore if timed-out:	0 TO
PLC-5 Data Table Address:	N7:10	to be retried:	0 NR
Size in Elements:	8	awaiting execution:	0 EW
Local/Remote:	REMOTE	continuous:	1 CO
Remote Station:	014	error:	0 ER
Link ID	00	message done:	0 DN
Remote Link Type:	DATA HIGHWAY	message transmitting:	1 ST
Local Node Address:	21	message enabled:	1 EN
Processor Type:	PLC-2		
Destination Data Table Address:	050	control bit addr:	N30:20/11

ERROR CODE: 0

Press a key for desired function, or <ESC> or <RETURN> to exit monitor.

```
[
RUN   no forces      decimal data    decimal addr    PLC-5    Addr 11
      SIZE IN
      ELEMNTS
      F3              BIT
                        F9
```

Program Verification

To verify that the example programs above are executing properly, follow these steps:

1. Look at the PLC-5 file contents of integer file 7 by typing:
`<DISPLAY MONITOR> N7:0`
2. Change any value in word locations 0 through 7 in this file.
3. These values in word locations 10 through 17 should be the same as the values in word locations 0 through 7.

Important: These PLC-5 slave to PLC-2 master example is for testing only. Toggling the continuous bit to ON generates high network traffic which, in most cases, is not necessary.

Example 3: Slave to Slave Communication

In this example, we send a message from the PLC-5 with Data Highway Plus address 013 (octal), to the PLC-5 at Data Highway Plus address 011 (octal).

In this case, the PLC-5 sends the command to:

- local destination: address 023
- remote destination: address 011

The command remains in the 1785-KE (address 023) buffer until the master polls address 013. The 1785-KE recognizes address 013 as an address on the Data Highway Plus link and sends the command to the master. The master sees that the destination address (011) is not its own address and immediately retransmits the message onto the multidrop link. The 1785-KE at address 021 recognizes address 011 and passes the command through to the PLC-5 at that address. The PLC-5 at address 011 then executes the command, generates a reply, and sends it to the 1785-KE at address 021. The 1785-KE buffers the message and awaits a poll for address 011 from the master. The master then forwards the reply to the PLC-5 at address 013.

Both 1785-KE modules are transparent to the master.

The following examples show the T50 message instructions necessary to send PLC-5 Read and Write commands from the PLC-5 (address 013 octal) to the PLC-5 (address 011 octal) through the 1785-KE modules.

PLC-2 Unprotected Write

This example writes eight words from the local PLC-5 (address 013 octal) integer file 7, word locations 0 through 7, to the remote PLC-5 (address 011 octal) integer file 7 word locations 0 through 7.

Program a message (MSG) instruction with the parameters shown below. Also, you must set up the message instruction for continuous mode by toggling bit N30:0/11 to ON.

MESSAGE INSTRUCTION DATA MONITOR FOR CONTROL BLOCK N10:20

Read/Write:	WRITE	ignore if timed-out:	0 TO
PLC-5 Data Table Address:	N7:0	to be retried:	0 NR
Size in Elements:	8	awaiting execution:	0 EW
Local/Remote:	REMOTE	continuous:	1 CO
Remote Station:	011	error:	0 ER
Link ID	00	message done:	0 DN
Remote Link Type:	DATA HIGHWAY	message transmitting:	1 ST
Local Node Address:	23	message enabled:	1 EN
Processor Type:	PLC-2		
Destination Data Table Address:	N7:0	control bit addr:	N10:20/11

ERROR CODE: 0

Press a key for desired function, or <ESC> or <RETURN> to exit monitor.

```
[
RUN   no forces      decimal data    decimal addr    PLC-5    Addr 11
      SIZE IN
      ELEMNTS
      F3              BIT
                        F9
```

Read Command

This example reads the eight words that were written to the remote PLC-5 (address 011 octal) in the last example. The instruction stores the data in the local PLC-5 (address 013 octal) integer file 7, word locations 10 through 17.

Program a message (MSG) instruction with the parameters shown below. Also, you must set up the message instruction for continuous mode by toggling bit N30:20/11 to ON.

MESSAGE INSTRUCTION DATA MONITOR FOR CONTROL BLOCK N10:20

Read/Write:	WRITE	ignore if timed-out:	0 TO
PLC-5 Data Table Address:	N7:0	to be retried:	0 NR
Size in Elements:	8	awaiting execution:	0 EW
Local/Remote:	REMOTE	continuous:	1 CO
Remote Station:	011	error:	0 ER
Link ID	00	message done:	0 DN
Remote Link Type:	DATA HIGHWAY	message transmitting:	1 ST
Local Node Address:	23	message enabled:	1 EN
Processor Type:	PLC-5		
Destination Data Table Address:	N7:0	control bit addr:	N10:20/11

ERROR CODE: 0

Press a key for desired function, or <ESC> or <RETURN> to exit monitor.

```
[
RUN   no forces      decimal data    decimal addr    PLC-5    Addr 11
      SIZE IN
      ELEMNTS
      F3              TOGGLE
                        BIT
                        F9
```

Program Verification

To verify that the example programs above are executing properly, follow these steps:

1. Look at the PLC-5 (node 51 octal) file contents of integer file 7 by typing:
`<DISPLAY MONITOR> N7:0`
2. Change any value in word locations 0 through 7 in this file.
3. These values in word locations 10 through 17 should be the same as the values in word locations 0 through 7.

Important: These PLC5 to PLC5 examples are for testing only. Toggling the continuous bit to ON generates high network traffic which, in most cases, is not necessary.

Polling More Than One PLC-5 on a Data Highway Plus

Since the 1785-KE Series B is transparent to the master, remote PLC-5's can be polled as individual slaves whether there is one or multiple PLC-5's attached to a given 1785-KE. As a result, PLC-5's on a remote DH + can be polled as though they were individual slave stations. Figure 5.5 illustrates this application.

Figure 5.5

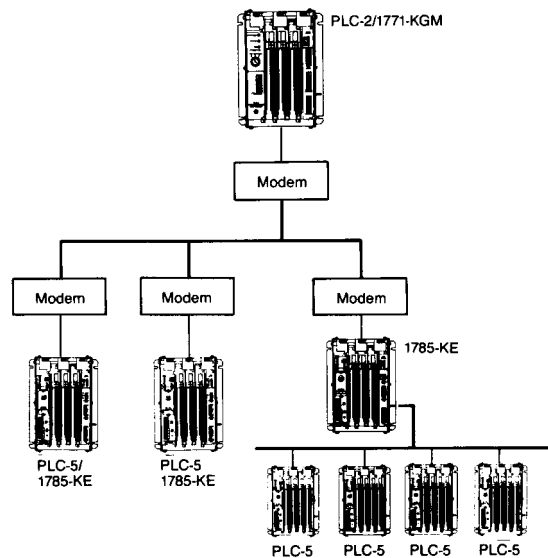

17052

Using the Multidrop Expansion Digit

As mentioned earlier, the valid range of slave addresses on the multidrop network is 001-376 octal (010-077 and 110-376 octal when a 1771-KGM is used as the master). The valid range of addresses on Data Highway Plus is 00-77 octal.

Figure 5.6
Switch Assembly SW-2

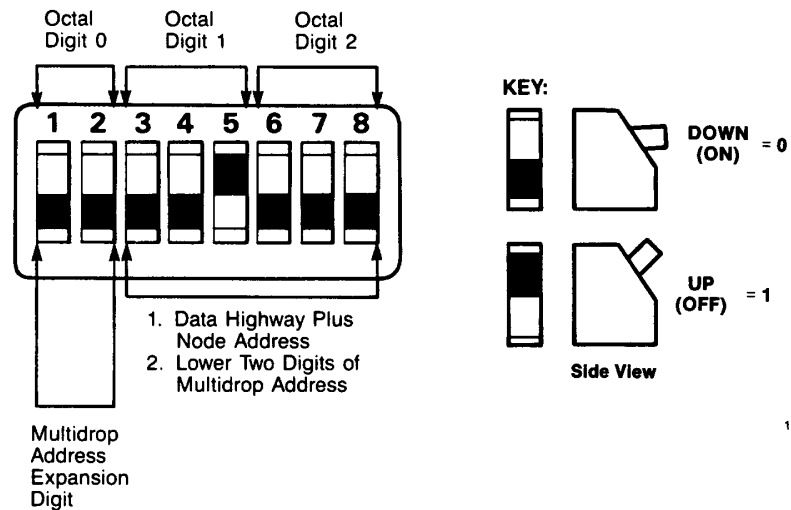

17053

Octal Digit 0 Multidrop Address Expansion Digit

To set Octal Digit 1 to:	Set switches 1 - 2	
	No.1	No.2
0	DWN (ON)	DWN (ON)
1	DWN (ON)	UP (OFF)
2	UP (OFF)	DWN (ON)
3	UP (OFF)	UP (OFF)

Important: The 1785-KE Series B uses the convention DOWN (ON) = Binary 0, and UP (OFF) = Binary 1.

Note from the figure that three octal digits are available: Octal Digit 0, Octal Digit 1, and Octal Digit 2.

Use Octal Digits 1 and 2 to set the 1785-KE's Data Highway Plus address from 00-77. These digits also set the lower two digits of the 1785-KE's address on the multidrop network.

Octal Digit 0 is a multidrop address expansion digit. It sets the most significant (highest) digit of the 1785-KE multidrop address. If you need to use multidrop addresses higher than 000-077, you will need to set this digit to 1, 2, or 3.

Figure 5.7 below shows an example of using this digit.

Figure 5.7

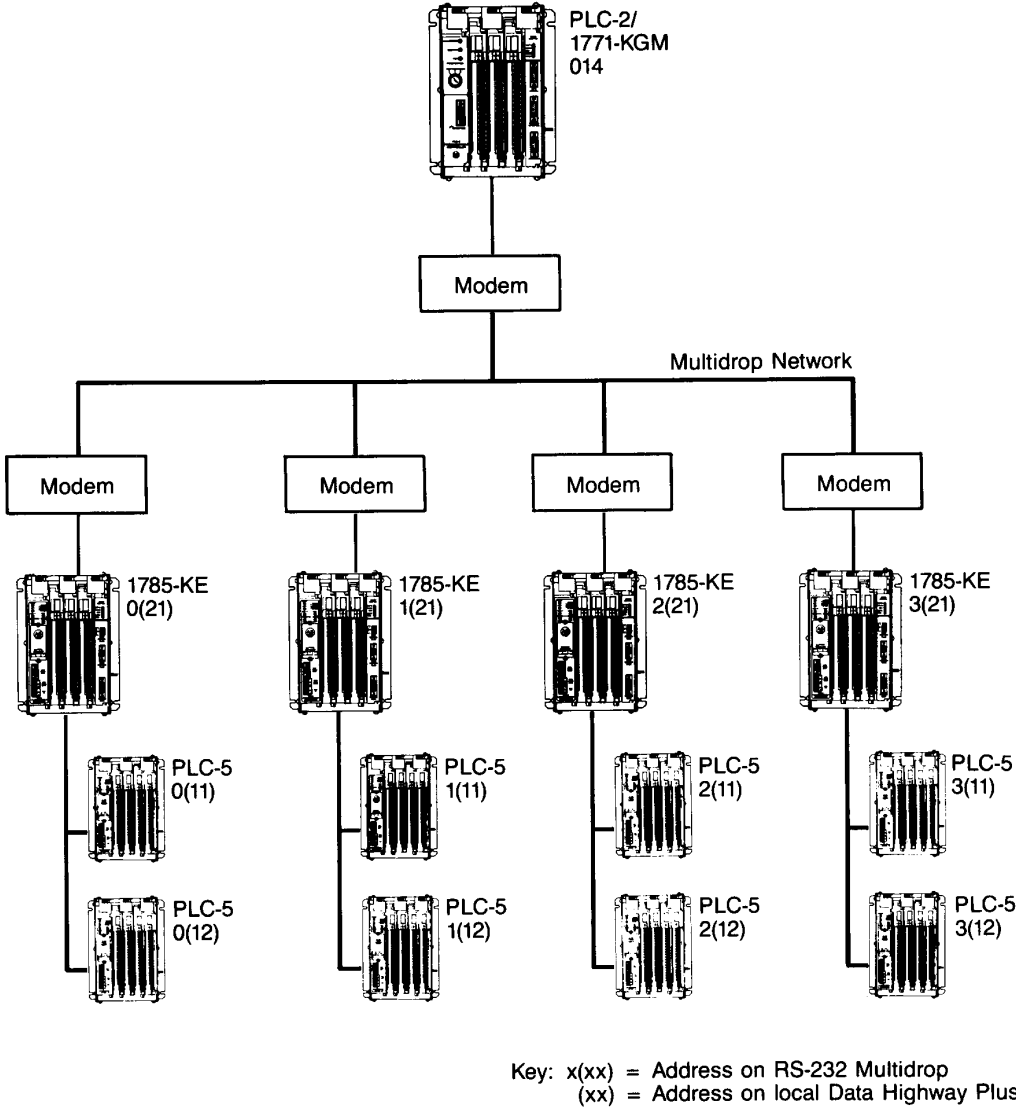

Chapter 5

Communicating Through the 1785-KE Module

As you can see from the figure, the value of Digit 0 determines both the address of the 1785-KE on the multidrop. This allows you to expand the total number of 1785-KE and PLC-5 addresses on the multidrop beyond the 00-77 (octal) limitation of DH+.

The figure shows that all of the 1785-KE's have address 21 octal on their respective DH+ networks. The PLC's have addresses of 11 and 12 on their DH+ networks. By setting Digit 0, you change the address as seen by nodes on the multidrop as follows:

Value of Octal Digit 0	Address on DH +	Address on Multidrop
0	1785-KE: 21 PLC-5:11 PLC-5:12	1785-KE: 021 PLC-5: 011 PLC-5: 012
1	1785-KE: 21 PLC-5: 11 PLC-5: 12	1785-KE: 121 PLC-5:111 PLC-5:112
2	1785-KE: 21 PLC-5:11 PLC-5:12	1785-KE: 221 PLC-5: 211 PLC-5: 212
3	1785-KE: 21 PLC-5: 11 PLC-5: 12	1785-KE: 321 PLC-5: 311 PLC-5:312

1785-KE Diagnostic Tools

Chapter Objectives

In this chapter, we provide:

- descriptions of the LED indicators on the front panel of the 1785-KE
- a list of 1785-KE diagnostic counters and a description of what they contain

For information on error codes and the diagnostic indicators of other Data Highway Plus and Data Highway modules, refer to the Data Highway/Data Highway Plus Protocol and Command Set Reference Manual (publication 1770-6.5.16).

Using the LED Indicators

There are 5 LED indicators on the front panel of the 1785-KE module (figure 6.1). These indicators can help you in diagnosing problems with the module's installation and operation.

Figure 6.1
The LED Indicators

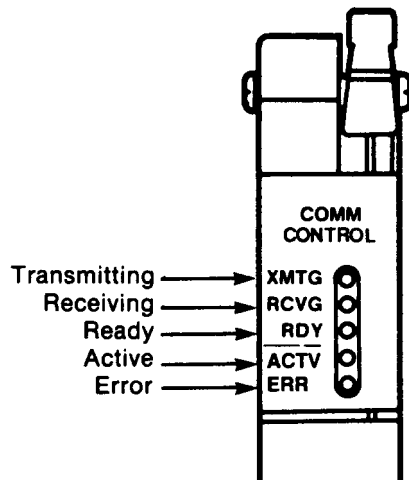

The following table contains the meaning of each LED on the front panel of the 1785-KE.

This LED:	Lights:
XMTG	when the 1785-KE module is passing the token. transmitting a command, or transmitting a reply message on Data Highway Plus.
RCVG	when the module is receiving a command or reply message from another node on Data Highway Plus.
RDY	when the module has a message stored in its transmit buffer and it is waiting to acquire the token so it can transmit
ACTV	<p>stays lit when the cable between the COMPUTER (RS-232-C) connector and the interfacing RS-232-C device is properly connected. This light will appear to flicker whenever characters are being transmitted across the RS-232-C link. If this light goes off, check the cable and connectors for possible problems.</p> <p>Note: This ACTV LED is hardware (not software) driven.</p>
ERROR	<p>At power up, this light flashes if the power up tests (integrity checks of internal memory, timers, and firmware) fail.</p> <p>After power up:</p> <ul style="list-style-type: none"> ▪ this light flashes for approximately half a second every time the module transmits or receives a DLE NAK protocol sequence on the RS-232-C link. If this light flickers frequently or stays on, the RS-232-C link might need better isolation or noise immunity. ▪ flashes at approximately 1 Hz when a duplicate node (two nodes with the same node number) is detected on the Data Highway Plus link ▪ comes on and stays lit when an internal hardware fault is detected

If the RCVG LED remains lit and the XMIT LED appears to flicker, then the module is passing the token or sending messages.

The 1785-KE Diagnostic Counters

The following sections tell you:

- what a diagnostic counter is
- how to read diagnostic counters
- what types of information the 1785-KE counters contain

What is a Diagnostic Counter?

A diagnostic counter records an event of interest for debugging the module and for longer term reliability analysis.

The diagnostic counters occupy a block of the module's internal scratch RAM. Most are single byte counters that wrap around to zero when they overflow.

These counters provide a useful tool for diagnosing problems.

How to Read Diagnostic Counters

To read diagnostic counters, you must issue a **Diagnostic Read** command. This command can only be sent from a device:

- connected to a Data Highway Plus module that supports an asynchronous port
- that can format the diagnostic commands

Therefore, a PLC user program is unable to initiate a Diagnostic Read command.

Important: The location of the diagnostic counters in a Data Highway Plus module varies:

- from module to module
- between revision levels of the same type module

You must first request the location of these counters by transmitting a **Diagnostic Status** command to the module. Based on the address returned, you can use the number of the counters which follow as an offset to calculate:

- the location of a particular counter
- how many counter values you want returned

You can then use this information to format a Diagnostic Read command. The reply from the Diagnostic Read command will contain the data stored in the counters.

For more information on the Diagnostic Status and Diagnostic Read commands, refer to the Data Highway/Data Highway Plus Protocol and Command Set Reference Manual (publication 1770-6.5.16).

1785-KE Data Highway Plus Diagnostic Counters

The 1785-KE stores 29 diagnostic counters in a total of 35 bytes. The following table contains a list of 1785-KE Data Highway Plus diagnostic counter bytes and what they contain.

Counter Byte:	What the Counter Contains:
0	received ACK with bad CRC
1	timeout expired with no ACK received
2	transmit retries exhausted
3	NAK/illegal protocol operation received
4	NAK/bad LSAP received
5	NAK/no memory received
6	received ACK/NAK too short
7	received ACK/NAK too long
8	something other than an ACK/NAK received
9	token pass timeout
10	token pass retries exhausted
11	claim token sequence entered
12	token claimed
13	bad CRC in received frame
14	NAK/ illegal protocol operation sent
15	NAK/bad LSAP sent
16	NAK/no memory sent
17	received frame too small
18	received frame too long
19	received a retransmission of a frame
20	received frame aborted (line noise)
21, 22	message successfully sent (low byte first)
23, 24	message successfully received (low byte first)
25, 26	command successfully sent (low byte first)
27, 28	reply successfully received (low byte first)
29, 30	command successfully received (low byte first)
31, 32	reply successfully sent (low byte first)
33	reply could not be sent
34	number of active nodes

Counter Byte:	What the Counter Contains:
35	count of messages attempted
36, 37	count of messages sent and ACKed
38, 39	count of ACKs received
40, 41	count of ACKs passed from RX to TX
42	count of NAKs received
43	count of NAKs passed from RX to TX
44	count of timeouts waiting for a response
45	count of ENQ's sent
46	count of messages that could not be sent
47	count of replies that could not be forwarded
48	count of messages received
49, 50	count of ACKs sent
51, 52	count of NAKs sent
53	count of ENQs received
54	count of retransmissions received and ACKed
55	count of STX (or SOH) received
56	count of messages ignored
57	count of messages aborted by DLE ENQ
58	count of messages aborted by control code other than ENQ
59	count of ACKs but no memory for next message
60	count of NAKs sent because of no memory
61	count of broadcasts received
62	count of broadcasts received successfully
63	count of messages not for this station
64	count of EOTs sent
65	count of calls received
66	count of times before phone hung up
67	count of times DCD lost
68	count of hang-ups due to DCD time-out

Specifications

Communication Rates

- Data Highway Plus: 57,600 bits per second
- RS-232-C Port: Switch selectable from 110 to 19200 bits/sec

Functions

- Interface a programmable RS-232-C compatible device with an Allen-Bradley Data Highway Plus network

Location

- 1771 I/O Rack

Communicating Ports

- Data Highway Plus: 3-screw terminal block
- 1784-T50 Terminal: 9-pin male EIA D-shell connector
- Asynchronous (RS-232-C): 15-pin female EIA D-shell connector

Cabling

- Asynchronous RS-232-C: Data Terminal Interface Cable (cat. no. 1770-CG or equivalent) or Modem Interface Cable (cat. no. 1770-CP or equivalent)
- Data Highway Plus: User-supplied Data Highway Plus dropline cable (Belden 9463)

Power Requirements

- 1.2A @ 5VDC

Ambient Temperature Rating

- 32°F to 140°F (0°C to 60°C) operational
- -40°F to 185°F (-40°C to 85°C) storage Ambient Humidity Rating

Ambient Humidity Rating

- 5% to 95% noncondensing

Definitions of RS-232-C Handshaking Signals

The table below gives definitions for each signal:

Signal:	What it Does:
TXD transmitted data	carries serialized data. It is an output from the module.
RXD received data	is serialized data input to the module. RXD and RXDRET are isolated from the rest of the circuitry on the modules.
RTS request to send	is a request from the module to the modem to prepare to transmit. RTS is always ON with full-duplex protocol. It typically turns the data carrier on. With half-duplex protocol, RTS is turned ON when the module has a message to transmit. Otherwise, RTS is OFF.
CTS clear to send	is a signal from the modem to the module that indicates the carrier is stable and the modem is ready to transmit. The module will not transmit until CTS is on. If CTS is turned off during transmission, the module will stop transmitting until CTS is restored.
DTR data terminal ready	<p>is a signal from the 1785-KE module to the modem to indicate that the module is operational and ready for communication. The module will continually assert DTR (except during an auto-answer application such as the one discussed in Chapter 4.)</p> <p>In auto answer applications, DTR is a signal from the module to the modem to connect to the phone line (i.e., "pick up the phone"). The module will assert DTR all the time except during the phone hangup sequence. Modems built to American standards will not respond to DTR until the phone rings. Some European modems will always pick up the phone, whether it is ringing or not. The 1785-KE module will not work with these types of European modems.</p>
DSR data set ready	<p>is a signal from the modem to the 1785-KE module to indicate that the modem is operational and ready for communication. If the 1785-KE module is in half-duplex mode, or in full-duplex mode with handshaking enabled (via the SW-1 switch selection discussed in Chapter 3), the 1785-KE requires the DSR signal to communicate. The module will not transmit or receive unless DSR is on. This signal is typically continually asserted by the modem (except during an auto-answer application such as the one discussed in Chapter 4.)</p> <p>If the modem does not properly control DSR, or if no modem is used, DSR must be jumpered to a high signal at the module's RS-232-C connector. Since DTR is held high by the module, DSR can be jumpered to DTR.</p> <p>In auto-answer applications, DSR is a signal from the modem to the module that the phone is off-hook. (It is the modems answer to DTR).</p>

Appendix B

Definitions of RS-232-C Handshaking Signals

Signal:	What it Does:
DCD data carrier detect	<p>is a signal from the modem to the module to indicate that the carrier from another modem is being sensed on the link. If the 1785-KE module is in half-duplex mode, or in full-duplex mode with handshaking enabled (via the SW-1 switch selection discussed in Chapter 3), the 1785-KE requires the DCD signal to communicate. modem does not properly control DCd, or if a modem is not being used, DCD can be jumpered to DTR at the module.</p> <p>In auto-answer applications, DCD should not be asserted unless the phone is off-hook.</p>
TXDRET transmitted data return	<p>is the return signal for TXD. It is connected to module logic ground through a resistor. It does not conform to RS-232-C specifications.</p>
RXDRET received data return	<p>is the return signal for RXD. It is connected to the isolated receiver and is isolated from all other circuitry on the module. It does not conform to RS-232-C specifications.</p>

Using a Series A 1785-KE Module

Appendix Objectives

The Series A version of the 1785-KE has the following differences from Series B:

- limited communication applications
- different option switches
- different front cover and connectors

The following sections describe the differences for each of these areas.

Replacing a Series A Module with a Series B Module

The Series A module operates like a Series B module in local mode.

If you are replacing a Series A 1785-KE with a Series B and want the operation to be compatible with your Series A module, set the Local/Remote switch on the Series B module to Local. Refer to Chapter 3 for more information.

Setting the Communication Option Switch

The Series A module has 6 switch assemblies (figure C.1) that enable you to select various communication options. The switch assemblies and their corresponding options are:

Select this switch assembly:	For this communication option:
SW-1	RS-232-C link features
SW-2	not used (switches must be OFF)
SW-3, SW-4	node number
SW-5	network link communication rate
SW-6	RS-232-C link communication rate and parity

Figure C.1
Location of the Assemblies on the Series A 1785-KE Module

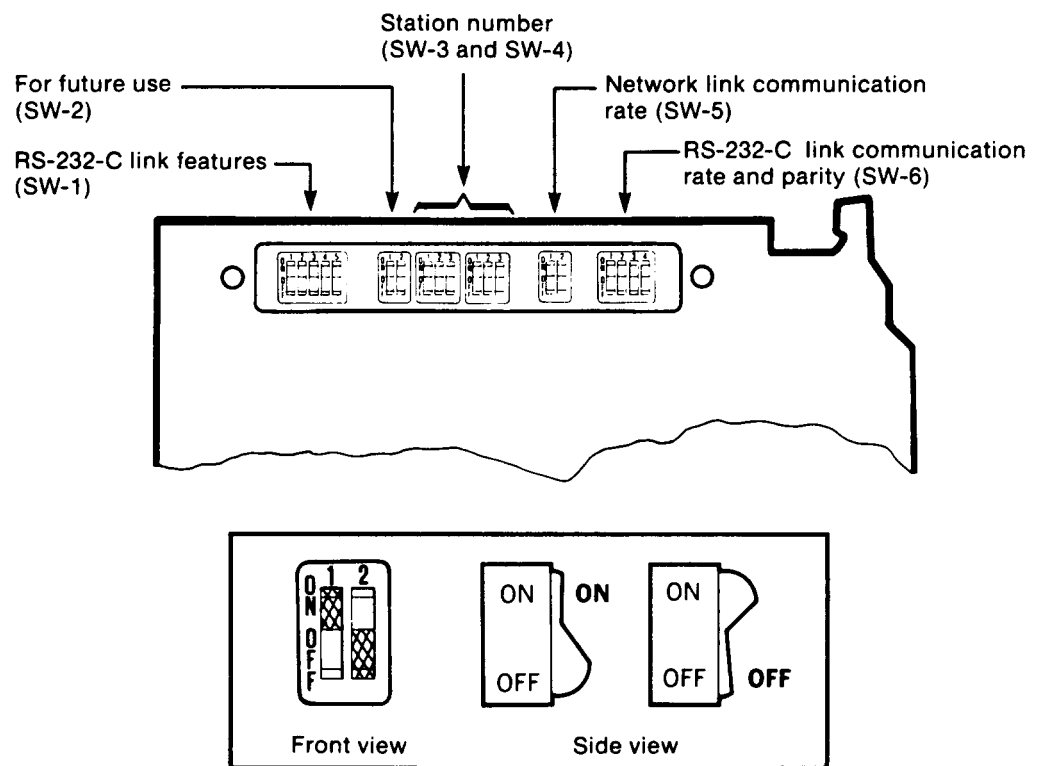

15223

**Switch Assembly SW-1:
RS-232-C Link Features**

Figure C.2 shows you the five switches in Switch Assembly SW-1:

Figure C.2
The Switches on Switch Assembly SW-1

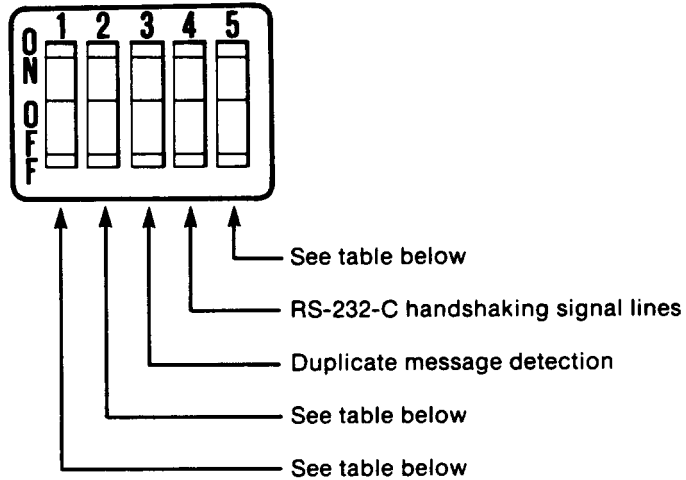

15224

The following table shows you how to set switches 1, 2, and 5 for the module options you require.

If you want to select protocol as:	With error check as:	with parity as:	With embedded responses:	Set these SW-1 switches:		
				1	2	5
full duplex	BCC	none	no	OFF	OFF	OFF
full duplex	BCC	even	no	ON	OFF	OFF
full duplex	BCC	none	yes	OFF	ON	ON
full duplex	BCC	even	yes	ON	ON	OFF
half duplex	BCC	none	no	OFF	OFF	OFF
half duplex	BCC	even	no	ON	OFF	OFF
full duplex	CRC	none	yes	OFF	ON	ON
half duplex	CRC	none	no	ON	ON	ON

Switch 3 determines whether or not the RS-232-C port of the Series A module can delete duplicate messages transmitted to it.

If you want the module to:	Set switch 3:
detect and ignore duplicate messages	ON
accept all messages regardless of duplication	OFF

Switch 4 determines whether the RS-232-C port on the Series A module uses and recognizes the following handshaking signals:

- data set ready (DSR)
- requests to send (RTS)
- clear to send (CTS)
- data carrier detect (DCD)
- data terminal ready (DTR)

If you want the port to:	Set switch 4:
use handshaking signals	ON
ignore handshaking signals	OFF

Switch Assembly SW-2: For Future Use

Switch assembly SW-2 is for future use.

You must set both switches on switch assembly SW-2 to OFF (figure C.3)

Figure C.3
Setting Switch Assembly SW-2

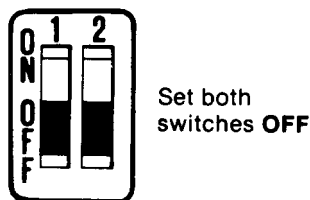

15225

**Switch Assemblies SW-3 and SW-4:
Node Number**

Switch assemblies SW-3 and SW-4 are for setting the node number of the 1785-KE module. The node number is an encoded 2-digit octal number that identifies the Series A module as a unique node on Data Highway Plus. Valid node numbers for the Series A module are 00 to 77 octal.

Figure C.4 shows you how to set the node number using switch assemblies SW-3 and SW-4. Use the switches in assembly

- SW-3 to set the first (left-most) digit
- SW-4 to set the second (right-most) digit.

Figure C.4
Setting Switch Assemblies SW-3 and SW-4

Switch Assembly	Set switches		
	No. 1	No. 2	No. 2
SW-3			
SW-4			
	If you want to set this digit		
	0	OFF	OFF
	1	OFF	ON
	2	OFF	ON
	3	OFF	ON
	4	ON	OFF
	5	ON	ON
	6	ON	OFF
	7	ON	ON

15226

For example, to set the node address to 37 octal, you would set switch assemblies SW-3 and SW-4 as shown below.

To set assembly:	To this number:	Set these switches:		
		1	2	3
SW-3	3	OFF	ON	ON
SW-4	7	ON	ON	ON

Switch Assembly SW-5: Network Link Communication Rate

Switch assembly SW-5 lets you select the communication rate for the Data Highway Plus port on the Series A module. Figure C.5 shows the switches on SW-5.

Figure C.5
The Switches on Switch Assembly SW-5

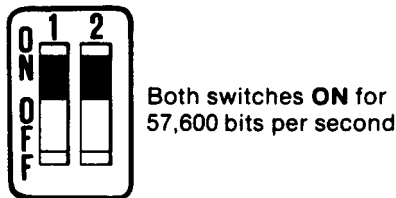

15227

Important: You must set both switches ON for SW-5. This is the setting for a communication rate of 57,600 bits per second on the Data Highway Plus.

Switch Assembly SW-6: RS-232-C Communication Rate and Diagnostic Commands

You use switch assembly SW-6 to select the communication rate and diagnostic commands for the RS-232-C port on the Series A module. Figure C.6 shows the switches on switch assembly SW-6.

Figure C.6
The Switches on Switch Assembly SW-6

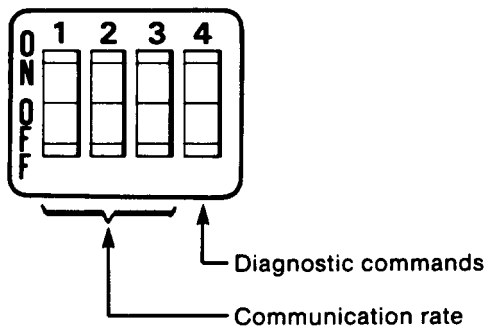

15228

To set the communication rate, you use switches 1, 2, and 3 on SW-6. Use the table below to set these switches:

To set this rate in bits per second:	Set these switches:		
	1	2	3
110	OFF	OFF	OFF
300	ON	OFF	OFF
600	OFF	ON	OFF
1200	ON	ON	OFF
2400	OFF	OFF	ON
4800	ON	OFF	ON
9600	OFF	ON	ON
19200	ON	ON	ON

To set diagnostic commands, you use switch 4 on SW-6. Use the table below to set switch 4.

If you want your module to:	Set switch 4:
execute diagnostic commands	ON
pass through diagnostic commands	OFF

Mounting the 1785-KE Module

The 1785-KE module mounts in an Allen-Bradley Bulletin 1771 I/O rack. If you are using a dropline/trunkline configuration, you must mount the 1785-KE module within 100 cable feet of the Data Highway Plus trunkline. When you are connecting the module directly to an RS-232-C device, you must mount the 1785-KE module within 50 cable feet of that device.

If the RS-232-C device is another Allen-Bradley communication module, you can mount the 1785-KE module up to 7,000 cable feet away from it by using the longline connection (discussed in Chapter 4.) If you are using a modem link to connect the 1785-KE module to the RS-232-C device, then the module and the device may be as far apart as the modem link will allow.

Making Connections to the Series A 1785-KE

The 1785-KE module has 3 connectors on its front edge (figure C.7).

Figure C.7
The Connectors on the Series A 1785-KE

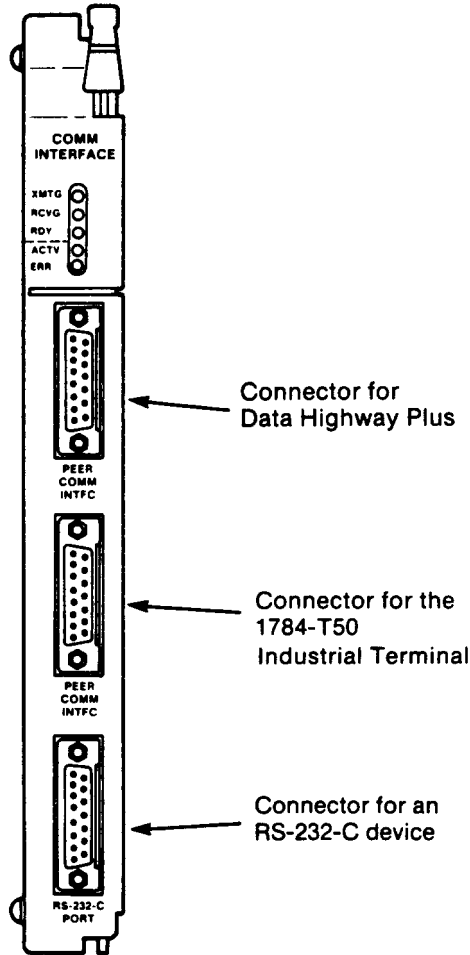

15230

You use the top connector, labeled **PEER COMM INTFC**, to connect the Series A 1785-KE to Data Highway Plus. Plug the 15-pin connector of your Data Highway Plus dropline into this connector. (For details on how to construct the dropline, refer to the Data Highway Cable Assembly and Installation Manual, publication 1770-6.2.1.)

You can use the center connector, labeled **PEER COMM INTFC**, to connect your 1784-T50 terminal to Data Highway Plus. You must use a cable with the pinouts shown in figure C.8.

Figure C.8
Pinouts for Connecting the 1784-T50 to the Series A 1785-KE

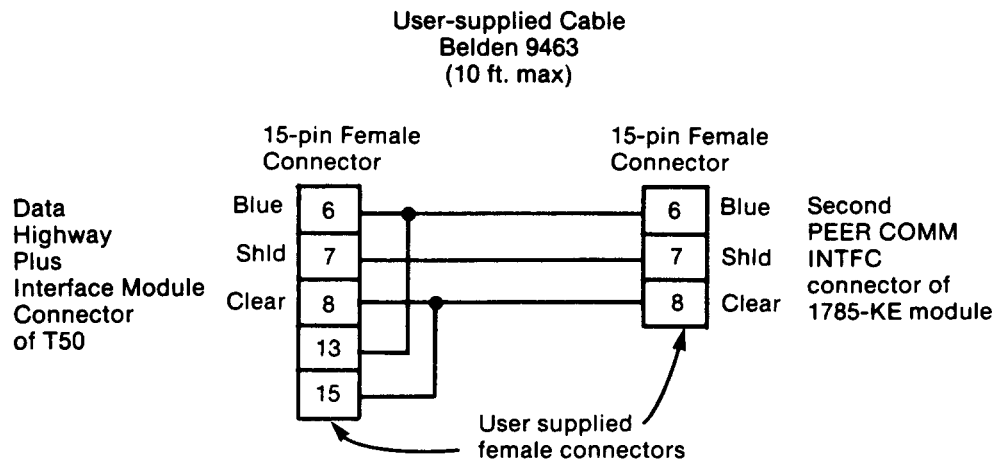

You use the bottom connector, labeled **RS-232-C PORT**, to connect an intelligent RS-232-C compatible device to the 1785-KE Series A module. Refer to Chapter 4 for guidelines on how to connect RS-232-C devices to the 1785-KE.

Interprocessor Addressing

Appendix Addressing

This Appendix discusses the following:

- How to address a PLC-5 from a PLC-2
- How to address a PLC-5 from a PLC-3
- Communicating from a computer to a PLC-5

How to Address a PLC-5 From a PLC-2

The PLC-2 does not understand the file structure of the PLC-5. When a PLC-2 sends a message to a PLC-5, the data is either read from or written to a default file in the PLC-5. This default file is the file number that corresponds to the decimal equivalent of the PLC-2's octal node address. For example, a PLC-2 with a node address of 012 (octal) will read data from and write data to file number 10 (012 octal = 10 decimal) in each of the PLC-5s on Data Highway Plus.

The file type of this file is not pre-defined, but the file must look like a PLC-2 data table to the PLC-2.

The following table shows the octal addresses, their decimal equivalents, and the PLC-5 reserved files. The first 9 files (0 – 8) are reserved for the data type listed.

Octal:	Decimal Equivalent:	PLC-5 Reserved File/File Type:
000	0	output file
001		input file
002	2	status file
003	3	bit file
004	4	timer file
005	5	counter file
006	6	control file
007	7	integer file
010	8	floating point
011 to 376	9 to 255 (a PLC-5 may have a file number up to 999)	user defined files

Make sure that:

- if you use a communications module with a node address of 000 to 010 (octal) to communicate with a PLC-5 using PLC-2 commands, the module must be able to properly communicate to the corresponding file type listed in the previous table.
- the file in the PLC-5 is created and is large enough to handle the command.
- you specify the address of the destination PLC-5 the same way that you would specify the address of another PLC-2.

The PLC-5's address is specified in the command rung of the PLC-2's command code specifications:

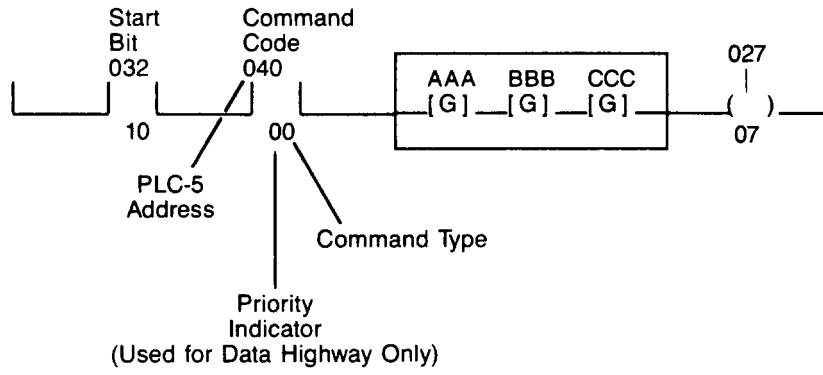

17056

AAA – beginning word addresses (in octal) of the remote node processor for read/write operation.

BBB – beginning word address (in octal) of the local node processor for read/write operation.

CCC – ending word address (in octal) of the local node processor for read/write operation.

Addressing a PLC-5 From a PLC-3

When sending a command to a PLC-5 from a PLC-3, use the following guidelines to program the message instruction.

The PLC-3 has six levels of addressing while the PLC-5 has only four levels. Therefore, if a PLC-5 received a full PLC-3 six-level address, it would return an error code. The following table summarizes the addressing levels of the PLC-3 and PLC-5.

Address Level	PLC-3 Family:	PLC-5 Family:
1	Major Section (3 = data table)	Major Section (0 = data table)
2	Context	File Number (must be 1 - 15)
3	Section	Element
4	File	Sub-Element
5	Structure	--
6	Word	--

To communicate from the PLC-3 to the PLC-5, you must enter the PLC-5 address in the following format:

\$ E [Major Section].[File #]. [Element].[Sub-Element]

A command of this format can be accepted by the PLC-5 because the address has only 4 levels.

Make sure that:

- the PLC-5 file you will communicate with is created and large enough to handle the command
- you specify the PLC-5 address in a message instruction as shown above. If you were to enter a PLC-5 address in normal PLC-3 address format (\$N1:0), the 1775-KA would format a six level address. If the PLC-5 receives a six-level address, it will be unable to read it and will return an error.

The following example shows a PLC-3 message instruction with a PLC-5 address:

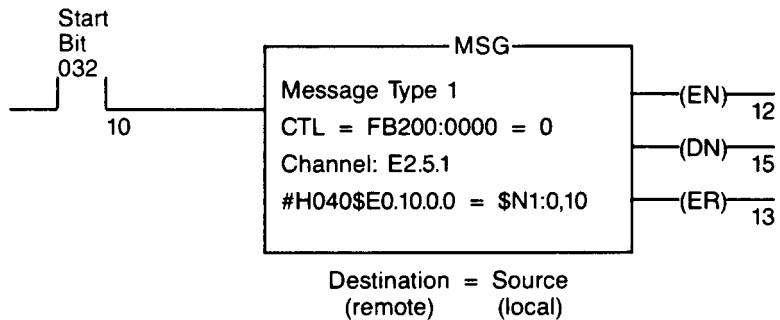

17057

Communicating From a Computer to a PLC-5

A computer can communicate with a PLC-5 on Data Highway Plus using the 1785-KE module. The table below gives a summary of PLC-5 data table areas based on the type of commands your computer sends.

The extent to which your computer can access PLC-5 data table areas depends on the addressing capabilities of the computer's software. Refer to the Data Highway/Data Highway Plus Protocol and Command Set Reference Manual (publication 1770-6.5.16) for information necessary to create a Data Highway of Data Highway Plus software driver for your computer.

If your computer executes:	Then your computer access data from:
the basic Command Set (CMD=01, CMD=08)	a single file in the PLC-5 data table. This file automatically defaults to the file number that is the decimal equivalent of the octal node address of the computer's interface module. For example, if the computer's octal node address is 20, the computer would read from and write to PLC-5 file 16 (20 octal = 16 decimal). You can change the default file to any file in a PLC-5 by issuing a Modify PLC-2 Compatibility File command.
PLC-5 Commands or PLC-3 Word Range Read or Write (CMD-OF and	all files in the PLC-5 data table. The computer must have the capability to format the appropriate packet in logical ASCII or logical binary format.



Allen-Bradley, a Rockwell Automation Business, has been helping its customers improve productivity and quality for more than 90 years. We design, manufacture and support a broad range of automation products worldwide. They include logic processors, power and motion control devices, operator interfaces, sensors and a variety of software. Rockwell is one of the worlds leading technology companies.

Worldwide representation.



Argentina • Australia • Austria • Bahrain • Belgium • Brazil • Bulgaria • Canada • Chile • China, PRC • Colombia • Costa Rica • Croatia • Cyprus • Czech Republic • Denmark • Ecuador • Egypt • El Salvador • Finland • France • Germany • Greece • Guatemala • Honduras • Hong Kong • Hungary • Iceland • India • Indonesia • Ireland • Israel • Italy • Jamaica • Japan • Jordan • Korea • Kuwait • Lebanon • Malaysia • Mexico • Netherlands • New Zealand • Norway • Pakistan • Peru • Philippines • Poland • Portugal • Puerto Rico • Qatar • Romania • Russia-CIS • Saudi Arabia • Singapore • Slovakia • Slovenia • South Africa, Republic • Spain • Sweden • Switzerland • Taiwan • Thailand • Turkey • United Arab Emirates • United Kingdom • United States • Uruguay • Venezuela • Yugoslavia

Allen-Bradley Headquarters, 1201 South Second Street, Milwaukee, WI 53204 USA, Tel: (1) 414 382-2000 Fax: (1) 414 382-4444