

KFL®

KFL-DC Serials
Electromagnetic Flowmeters

User Manual

CONTENTS

1. Profile.....	1
2. Structure and Operating Principle.....	1
3. Specification.....	2
4. Model and Suffix Code.....	5
5. Material Selection.....	6
6. Dimensions.....	6
7. Connection and Operation of Converter.....	9
8. Setting Parameters.....	16
9. Recording Time When Power Turn-Off (with Power Turn-Off Function).....	19
10. Recording Gross of hour.....	20
11. Infrared Telecontrol Function Keys.....	20
12. Alarm Information.....	20
13. Installation.....	20
14. Troubleshooting.....	26

1. Profile

KFL-DC series electromagnetic flowmeters follow the Faraday law of electromagnetic induction. They can be used to accurately measure the flow rate of liquids which are electrical conducting, caustic, and mixed with liquids and solids. They are widely used throughout industries of petroleum, chemical engineering, pharmacology, papermaking, electric power, environmental protection and so forth.

Features:

- No Moving Parts, Virtually No Pressure Loss;
- Corrosion protection, abrasion resistant;
- High accuracy, Stable performance;
- High level of anti-vibration and anti-jamming, wide measuring dimensions.
- Multi-Output Interface : 4~20mA, Pulse, Alarm Outputs, RS-485 and Modbus Communication.

2. Structure and Operation Principle

2.1. Structure

KFL-DC series electromagnetic flowmeters are made up of sensor and transducer, together with LCD screen, current and pulse output, alarm signal and RS-485 communication.

2.2 Operating Principle

Faraday’s Laws of Induction form the basis for the electromagnetic flowmeters. It states that a voltage is induced in a conductor as it moves through a magnetic field.

This principle is applied to a conductive fluid which flows through a magnetic field generated perpendicular to the flow direction (see Schematic).

The voltage induced in the fluid is measured at two electrodes, installed diametrically opposed. This signal voltage U_E is proportional to the magnetic induction B , the electrode spacing D and the average flow velocity v . Noting that the magnetic induction B and the electrode spacing D are constants, a proportionality exists between the signal voltage U_E and the average flow velocity v . The equation for the volume flow shows that the signal voltage U_E is linear and proportional to the volume flowrate. The induced signal voltage is processed in the converter into scaled, analog and digital signals.

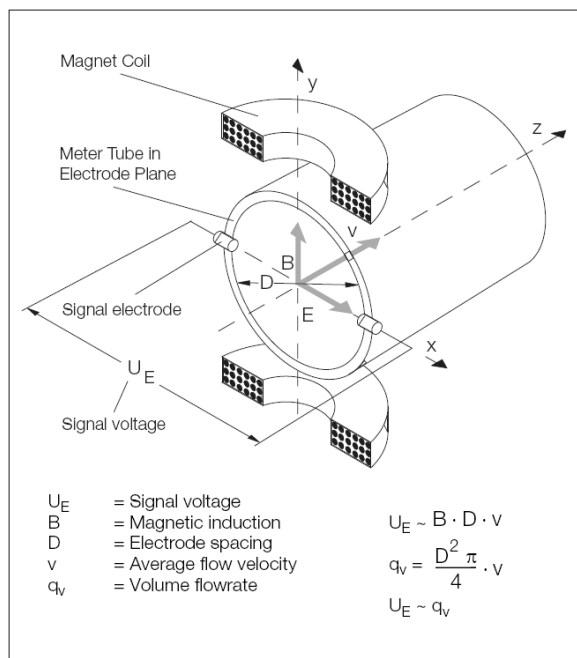

Fig. 1: Electromagnetic Flowmeter Schematic

3. Specifications

- **Nominal Meter Size**
10 to 1000mm (3/8 to 40 inch)
- **Liquid Pressure (MPa)**
1.0, 1.6, 2.5, 4.0, 16, 25
- **Accuracy**
±0.5%, ±1% (upon req.)
- **Minimum Conductivity**
>5µs/cm
- **Electrode Material**
SST 316L (standard), Hastelloy, Tantalun, titanium, Tungsten Carbide (upon req.)
- **Fluid Temperature**
-25 to 65°C (-13 to 149°F)
-25 to 140°C(-13 to 284°F)(opt.)
- **Liner**
PO, PTFE, PFA
- **Relative Humidity**
≤85%
- **Ambient Temperature**
-30 to 60°C (-22 to 140°F)
- **Analog Output Effects**
Same as pulse output plus ±0.1% of rate ±0.01mA
- **Current Output**
0 to 10mA or 4 to 20mA
- **Frequency Output**
0 to 5000Hz with photoelectric isolation
- **Pulse Output**
Adjustable from 0.001 to 1000 Ltr/Pulse
- **Alarm Output**
Upper Alarm-ALMH, Lower Alarm-ALML with photoelectric isolation
Upper Alarm-ALMH, Lower Alarm-ALML with photoelectric isolation
- **Communications**
RS-232 without galvanic isolation
RS-485 with galvanic isolation, MODBUS.
- **Supply Power**
85 to 250VAC (45 to 63Hz)
16 to 36VDC
- **Power**
S<10W/AC. S<7.5W/DC

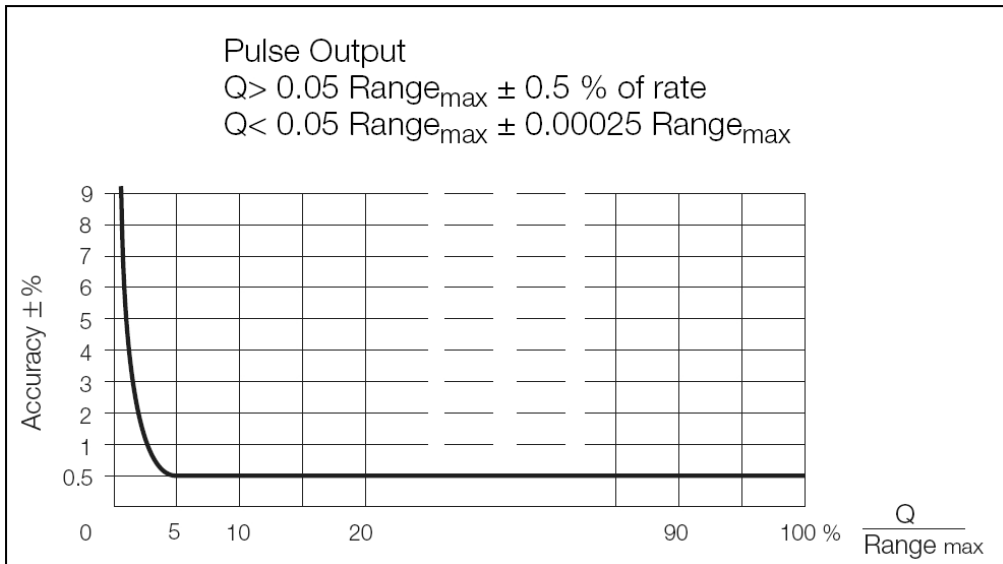

Fig. 2: Analog Output Effects

■ **Flow Ranges and Meter Sizes**

Meter Size		Min. Flow Range		Max. Flow Range	
		Flow Velocity		Flow Velocity	
DN		0 to 0.5 m/s	0 to 1.64 ft/s	0 to 10 m/s	0 to 32.81 ft/s
mm	Inch	l/min, m ³ /h	gpm	l/min, m ³ /h	gpm
10	3/8	0 to 2 l/min	0 to 0.52	0 to 40 l/min	0 to 11.88
15	1/2	0 to 5 l/min	0 to 1.32	0 to 100 l/min	0 to 26.41
20	3/4	0 to 7.5 l/min	0 to 1.98	0 to 150 l/min	0 to 39.62
25	1	0 to 10 l/min	0 to 2.64	0 to 200 l/min	0 to 52.83
32	1 1/4	0 to 20 l/min	0 to 5.28	0 to 400 l/min	0 to 105.66
40	1 1/2	0 to 30 l/min	0 to 7.92	0 to 600 l/min	0 to 158.50
50	2	0 to 3 m ³ /h	0 to 13	0 to 60 m ³ /h	0 to 264
65	2 1/2	0 to 6 m ³ /h	0 to 26	0 to 120 m ³ /h	0 to 528
80	3	0 to 9 m ³ /h	0 to 39	0 to 180 m ³ /h	0 to 792
100	4	0 to 12 m ³ /h	0 to 52	0 to 240 m ³ /h	0 to 1056
125	5	0 to 21 m ³ /h	0 to 92	0 to 420 m ³ /h	0 to 1849
150	6	0 to 30 m ³ /h	0 to 132	0 to 600 m ³ /h	0 to 2641
200	8	0 to 54 m ³ /h	0 to 237	0 to 1080 m ³ /h	0 to 4755
250	10	0 to 90 m ³ /h	0 to 396	0 to 1800 m ³ /h	0 to 7925
300	12	0 to 120 m ³ /h	0 to 528	0 to 2400 m ³ /h	0 to 10566
350	14	0 to 165 m ³ /h	0 to 726	0 to 3300 m ³ /h	0 to 14529
400	16	0 to 225 m ³ /h	0 to 990	0 to 4500 m ³ /h	0 to 19812
450	18	0 to 300 m ³ /h	0 to 1320	0 to 6000 m ³ /h	0 to 26417
500	20	0 to 330 m ³ /h	0 to 1452	0 to 6600 m ³ /h	0 to 29058
600	24	0 to 480 m ³ /h	0 to 2113	0 to 9600 m ³ /h	0 to 42267
700	28	0 to 660 m ³ /h	0 to 2905	0 to 13200 m ³ /h	0 to 59117
800	32	0 to 900 m ³ /h	0 to 3962	0 to 18000 m ³ /h	0 to 79251
900	36	0 to 1200 m ³ /h	0 to 5283	0 to 24000 m ³ /h	0 to 105668
1000	40	0 to 1350 m ³ /h	0 to 5943	0 to 27000 m ³ /h	0 to 118877

Table 1: Flow Ranges and Meter Size

■ **Flowrate Nomograph**

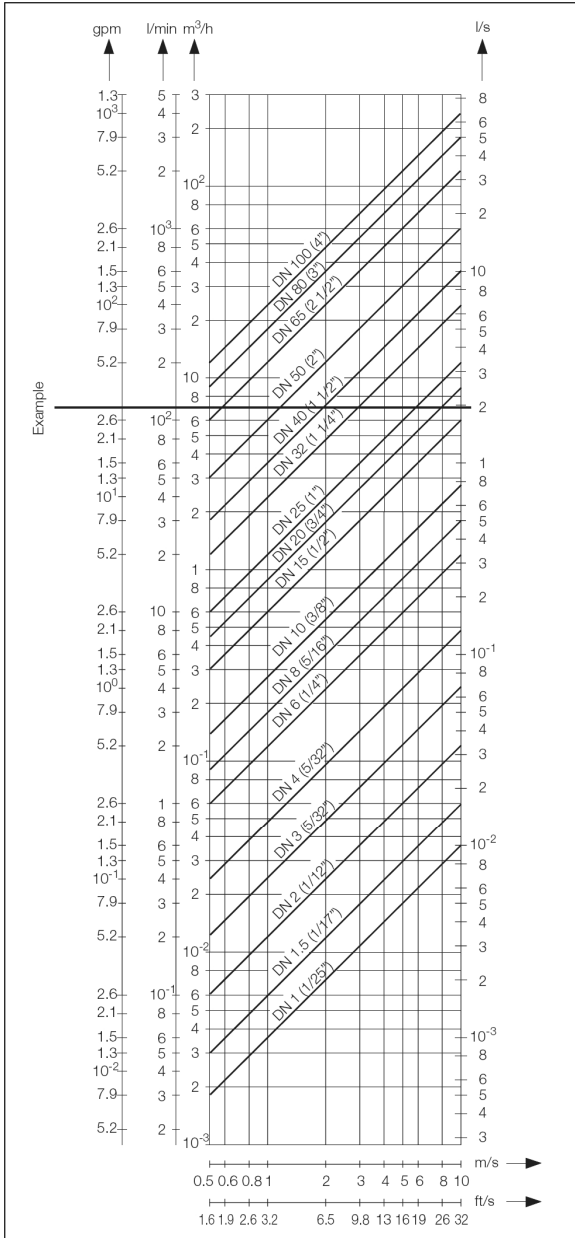

Fig. 2: Flowrate Nomograph DN1 to DN 100 (3/8" to 4")

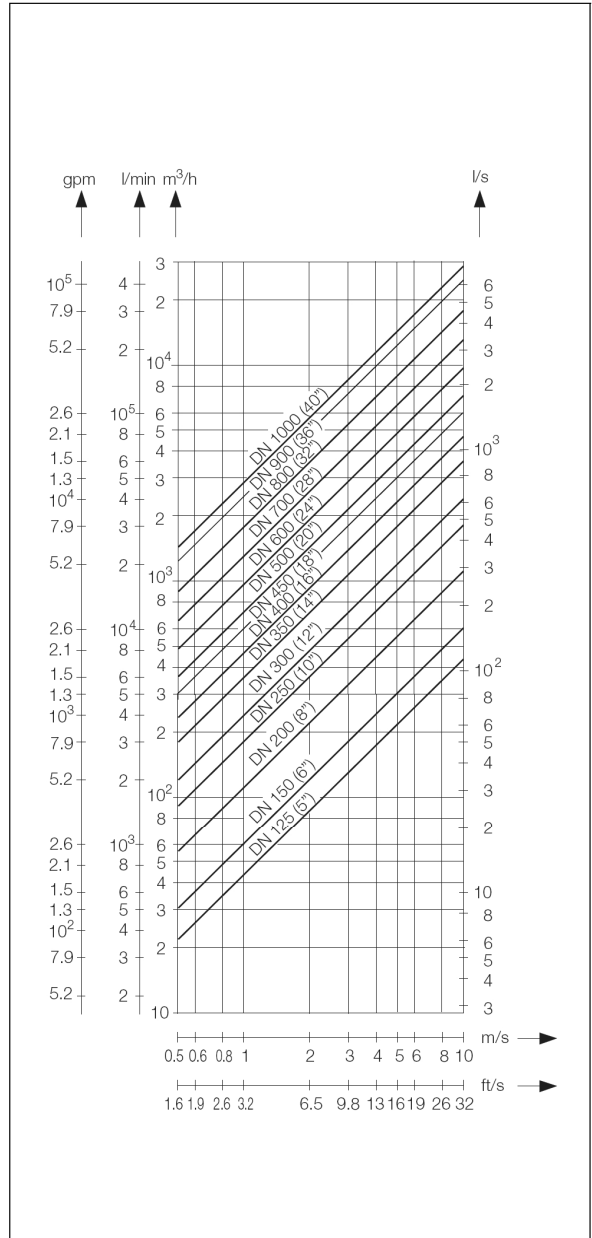

Fig. 3: Flowrate Nomograph DN 125 to 1000 (5" to 40")

Flowrate Nomographs

The volume flowrate is a function of the flow velocity and the flowmeter size. The Flowrate Nomographs, Fig. 2: and Fig. 3: indicate the flowrate range for a specific flowmeter size and which flowmeter sizes are suitable for a specific flowrate.

Example:

Flowrate = 7 m³/h [30.82 gpm] (Maximum value = range end value). Suitable are flowmeter sizes DN 20 to DN 65 [3/4" to 2-1/2"] for a flow velocity between 0.5 and 10 m/s [1.64 and 32.81 ft/s].

4. Model and Suffix Code

Model	Suffix Code	Description
KFL-DC-	Electromagnetic Flowmeter
	0010	Nominal Size 10 mm (3/8in.)
	0015	Nominal Size 15 mm (1/2in.)
Meter Size
	0200	Nominal Size 200 mm (8in.)

	1000	Nominal Size 1000 (40in.)
Construction	M.....	Integral Type for General Purpose
	N.....	Integral Type for Explosion Proof
	D.....	Remote Type for General Purpose
	E.....	Remote Type for Explosion Proof
Electrode Material (Note 1)	S.....	Stainless Steel 304
	L.....	Stainless Steel 316L
	H.....	Hastelloy
	T.....	Tantalum
	V.....	Titanium
	W.....	Tungsten Carbide
Lining (Note 1)	P.....	PO
	T.....	PTFE
	A.....	PFA
Output Signal	-L.....	Local (non signal output)
	-D.....	0-10mA
	-C.....	4-20mA
	-P.....	Pulse
	-F.....	Frequency
	-R.....	RS-232
	-S.....	RS-485
	-M.....	MODBUS
Earth Ring	N.....	Non Earth Ring
	E.....	Earth Ring
Liquid Pressure (MPa)	-1.0	PN. -1.0, -2.0, -2.5, -16, -25

Note 1: Users must consider the characteristics of selected wetted parts material and the influence of process fluids. The use of inappropriate materials can result in the leakage of corrosive process fluids and cause injury to personnel and/or damage to plant facilities. It is also possible that the instrument itself can be damaged and that fragments from the instrument can contaminate the user's process fluids. Be very careful with highly corrosive process fluids such as hydrochloric acid, sulfuric acid, hydrogen sulfide, sodium hypochlorite, and high-temperature steam (150°C [302°F] or above). Contact KFL for detailed information of the wetted parts material.

5. Material Selection

Several liner types, electrode materials, and electrode types are available on KFL-DC Series Electromagnetic Flowmeters to ensure compatibility with virtually any application. See Table. 2 for information on liner types, Table. 3 for information on electrode materials.

Lining Material	General Characteristics	Electrode Material	General Characteristics
PFA	Highly chemical-resistant Excellent high temperature capabilities	316L Stainless Steel	Good corrosion resistance Good abrasion resistance Not recommended for sulfuric or hydrochloric acids
PTFE	Highly chemical-resistant Excellent high temperature capabilities	Hastelloy	Better corrosion resistance High strength Good in slurry applications Effective in oxidizing fluids
		Tantalum	Better chemical resistance Not recommended for fluosilic acid, hydrofluoric acid, or sodium hydroxide
		Titanium	Better chemical resistance Better abrasion resistance Good for sea water applications Not recommended for hydrofluoric or sulfuric acid

Table. 2: Lining Material

Table. 3: Electrode Material

6. Dimensions

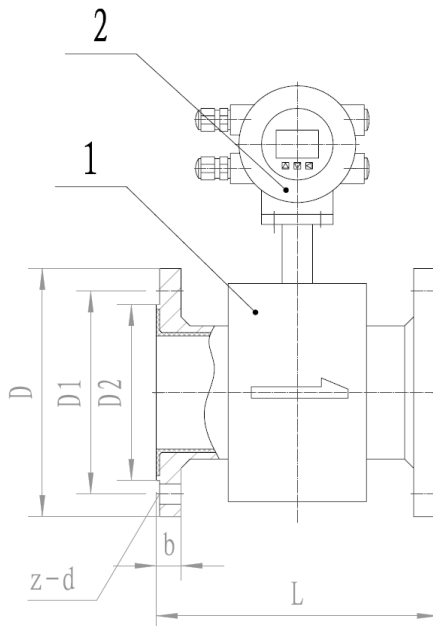

Fig. 4: Dimensions

Pressure Rating (ANSI CL)	Meter Size (DN)		Main External and Connecting Dimensions (mm)					
	in	mm	L	D	D1	D2	b	z-d
150	1/2	15	200	89	60.5	35	11.2	4-16
	3/4	20	200	98	70	43	11.2	4-16
	1	25	200	108	79.5	51	11.2	4-16
	1 ¹ / ₄	32	200	117	89	64	13	4-15
	1 ¹ / ₂	40	200	127	98.5	73	14.3	4-16
	2	50	200	152	120.5	92	15.9	4-19
	2 ¹ / ₂	65	200	178	139.5	105	17.5	4-19
	3	80	250	190	152.5	127	19.1	4-19
	4	100	250	229	190.5	157	23.9	8-19
	5	125	250	254	216	186	23.9	8-22
	6	150	300	279	241.5	216	25.4	8-22
	8	200	350	343	298	270	28.6	8-22
	10	250	400	406	362	324	30.2	12-25
	12	300	400	482.6	431.5	381	31.8	12-25
	14	350	400	533	476	413	35	12-29
	16	400	450	597	539.5	470	36.6	16-29
	20	500	450	699	635	584	42.9	20-32
	24	600	600	813	749.5	692	47.7	20-35
30	750	750	985	914	857	74.5	28-35	
36	900	900	1170	1086	1022	90.5	32-41	
40	1000	1000	1289	1200	1124	90.5	36-41	
300	1/2	15	200	95	66.5	35	14.2	4-16
	3/4	20	200	117	82.5	43	15.9	4-19
	1	25	200	124	89	51	17.5	4-19
	1 ¹ / ₄	32	200	133	98.5	64	19	4-19
	1 ¹ / ₂	40	200	156	114.5	73	20.7	4-22
	2	50	200	165	127	92	22.3	8-19
	2 ¹ / ₂	65	200	190	149	105	25.4	8-22
	3	80	250	210	168.5	127	28.6	8-22
	4	100	250	254	200	157	31.8	8-22
	5	125	250	279	235	186	35	8-22
	6	150	300	318	270	216	36.5	12-22
	8	200	350	381	330	270	41.3	12-25
10	250	400	445	387.5	324	47.7	16-29	

	12	300	400	520.8	451	381	50.8	16-32
	14	350	400	584.2	514.5	413	53.8	20-32
	16	400	450	647.8	571.5	470	57.2	20-35
	20	500	450	774.8	685.8	584	63.5	24-35
600	1/2	15	225	95	66.5	35	14.3	4-16
	3/4	20	225	117	82.5	43	15.9	4-19
	1	25	225	124	89	51	17.5	4-19
	1 1/4	32	225	133	98.5	64	21	4-19
	1 1/2	40	225	156	114.5	73	22.3	4-22
	2	50	225	165	127	92	25.4	8-19
	2 1/2	65	222	190.5	149.5	120.5	28.6	8-22
	3	80	250	210	168	127	31.8	8-22
900	1/2	15	225	121	82.5	35	22.4	4-22
	3/4	20	225	130	89	43	25.4	4-22
	1	25	225	149	101.5	51	28.5	4-25
	1 1/2	40	225	178	124	73	31.6	4-29
	2	50	225	216	165	92	38.1	8-26
	2 1/2	65	250	244	190.5	105	38.1	8-29
	3	80	250	241	190.5	127	38.1	8-26
	4	100	250	292	235	157	44.5	8-32
1500	1/2	15	225	121	82.5	35	25.4	4-22
	3/4	20	225	130	89	43	25.4	4-22
	1	25	225	149	101.5	51	28.5	4-25
	1 1/2	40	225	178	124	73	31.8	4-29
	2	50	225	216	165	92	38.1	8-25
	2 1/2	65	220	245	190.5	105	41.5	8-29
	3	80	250	267	203	127	47.8	8-32
	4	100	250	311	241.5	157	53.9	8-35
2500	1/2	15	225	135	89	35	30.5	4-22
	3/4	20	225	140	95	43	32	4-22
	1	25	225	160	108	51	35	4-25
	1 1/2	40	250	205	146	73	44.5	4-32
	2	50	300	235	171.5	92	51.5	8-29
	2 1/2	65	300	267	196.3	105	65	8-32
	3	80	300	305	228.6	127	74	8-35
	4	100	300	356	273	157	84	8-42

7. Connection And Operation Of Converter

7.1 Keys And Display

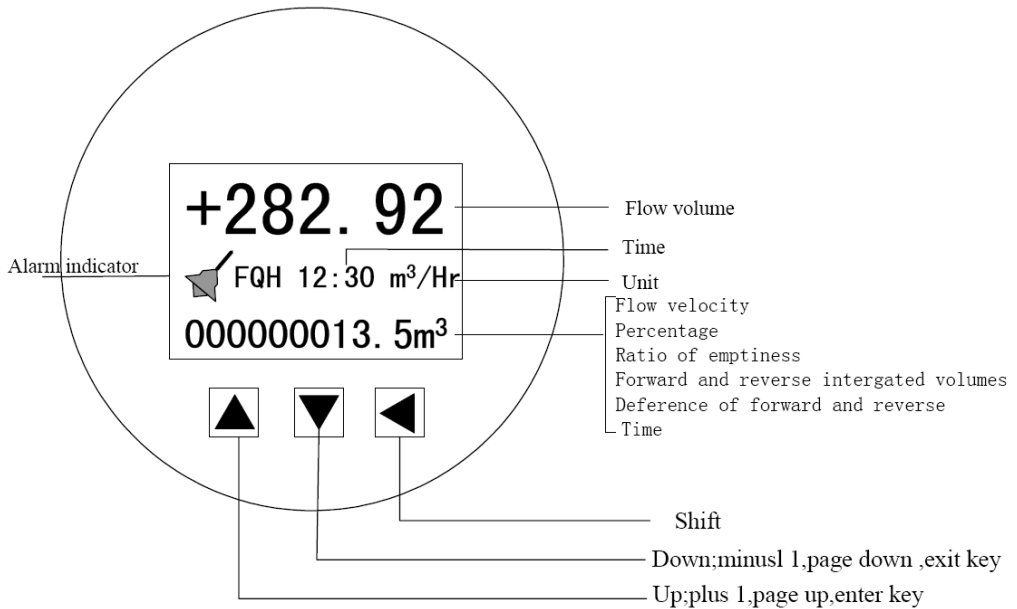

Fig. 5: Define Keys and LCD screen display

Instruction: Press enter key, the instrument enter into the setting parameters of select function. Movie the cursor under the enter key. Press it and then input password when password status "00000" can be seen. Movie the cursor under the enter key again. Press it And then hen input settings into selected item of operating manus .Please push "▼"key down for several seconds for returning to running status.

7.2 Connection Of Converter

7.2.1 Links And Labels Of Connector In Model

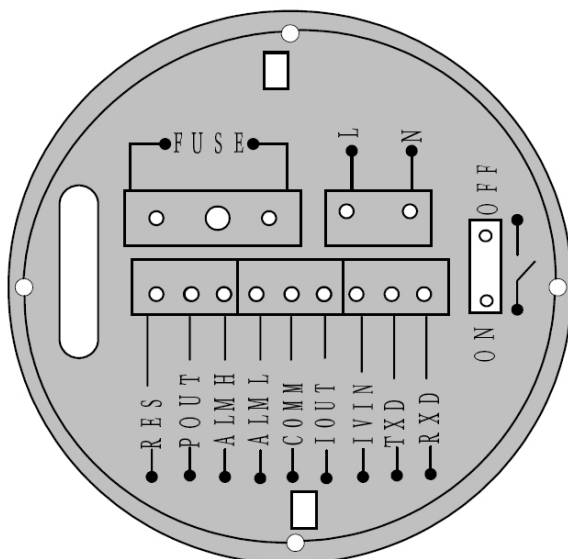

Fig. 6: Labels of connector in Model

7.2.2 Symbols And Description Of Connectors In Model

IOUT:	Output Current for Flow Measurement
ICOM:	Output Current (Ground) for Flow Measurement
POUT:	Frequency(Pulse) Output for Bi-directional Flow
PCOM:	Frequency (Pulse) Output (Ground)
ALML:	Alarm Output for Low Limit
AHMH:	Alarm Output for Upper Limit
RES:	Connect pull Resistance
FUSE:	Fuse for Power Supply
TXD:	+Communication Input Signal
RXD:	-Communication Input Signal
L:	110V Power Supply
N:	110V Power Supply

7.2.3 Output And Power Supply Cables

All cables for signals transferring and power supply have to be prepared users. However, it should be careful to choose the cables that meet the upper limit load of consuming current.

Pulse current output, alarm current output and external power supply can be seen in Fig. 7. When inductive load is connected to converter, diode should be used as in Fig. 7.

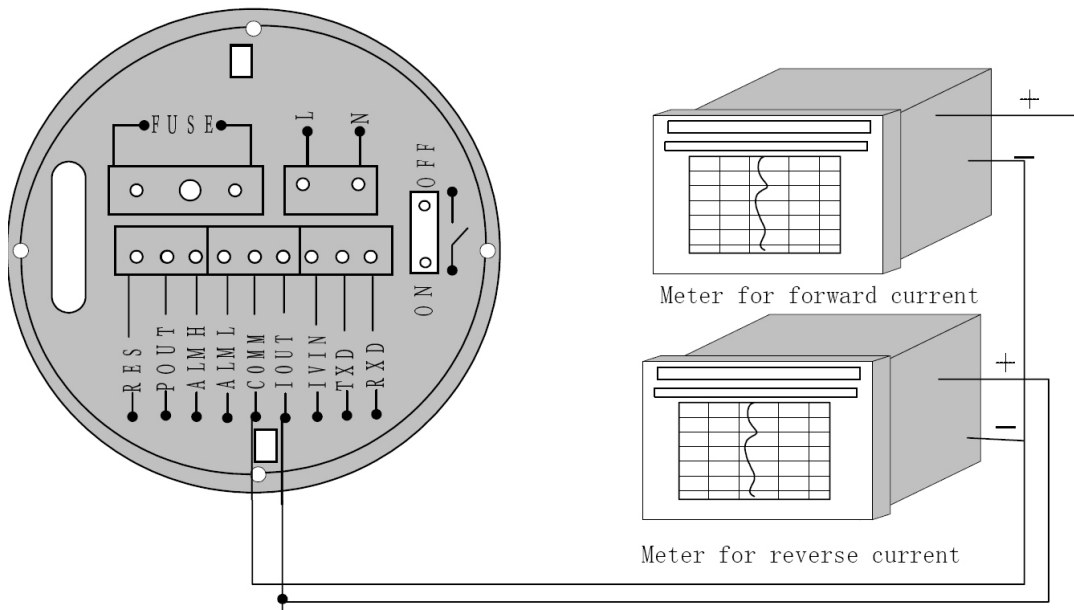

Fig. 7: (a) Connection of Current Output

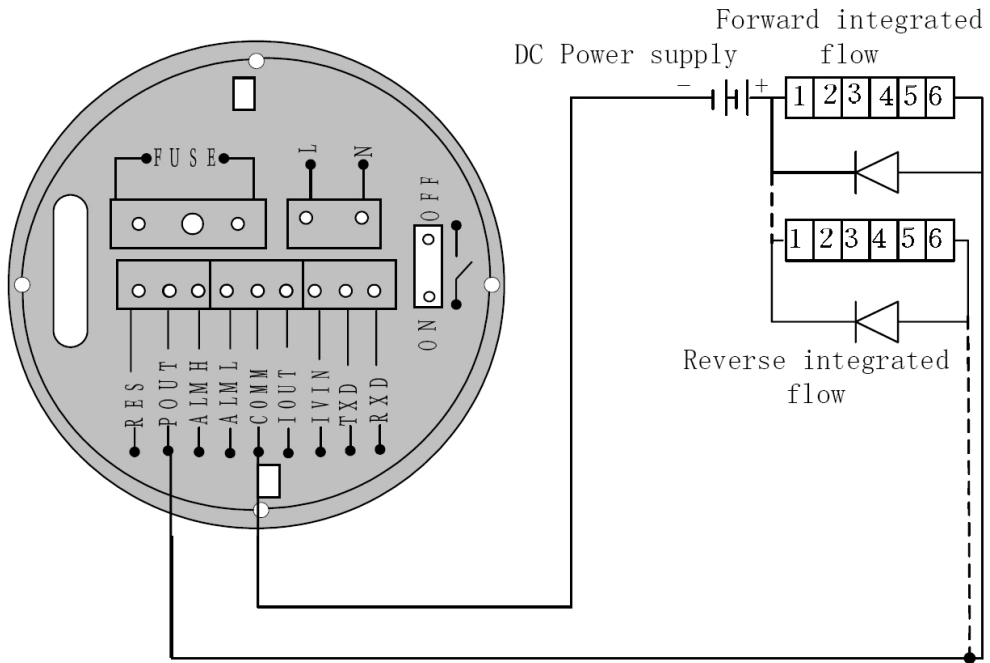

Fig. 7: (b) Connection of Electro-Magnet Counter

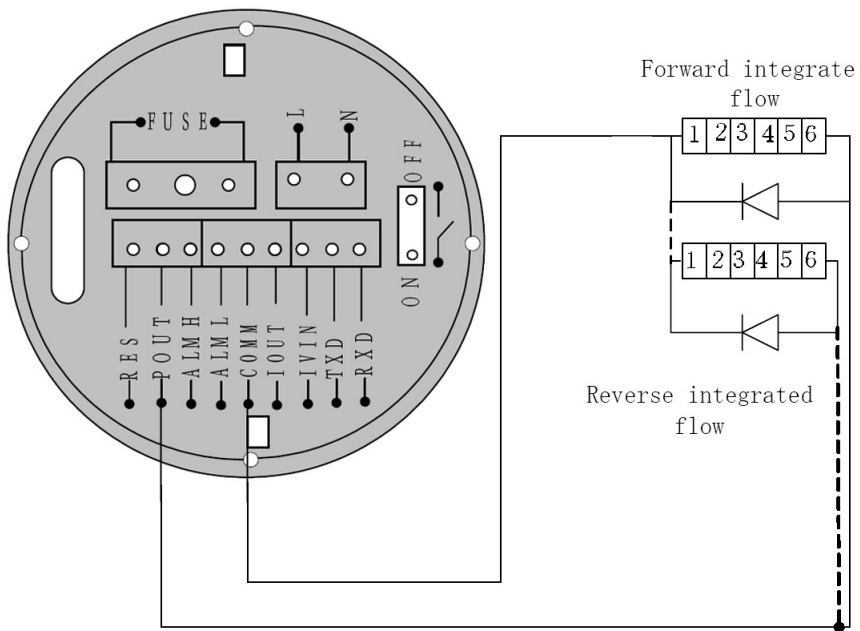

Fig. 7: (c) Connection of Electronic Counter

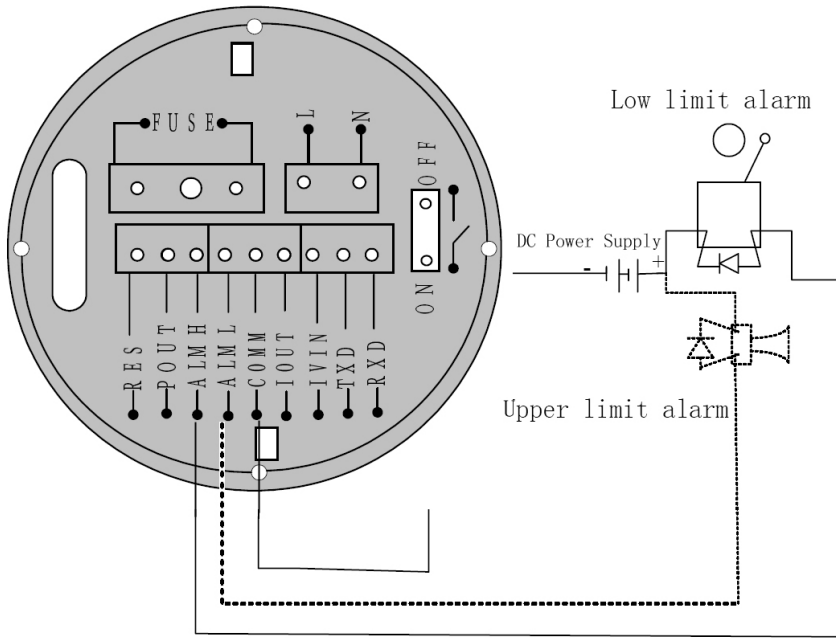

Fig. 7: (d) Connection of Alarm Output

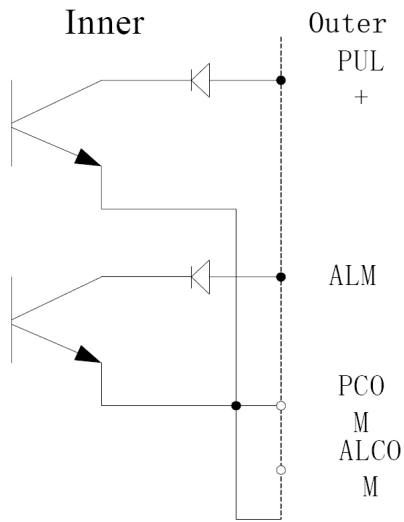

Fig. 7: (e) Connection of OC Gate

7.3 Digital Data Output And Count

Digital output is frequency output and pulse output. Frequency output and pulse output use the same connection output point, therefore, users can only choice one of frequency output and pulse output at the same time.

7.3.1 Frequency Output:

The range of frequency output is 0 ~ 5000HZ and frequency output opposes percent flux.

$$F = (\text{Measure value} / \text{Full scale value}) \cdot \text{the range of frequency}$$

The up limit of frequency output can be adjusted. It can be choice from 0 ~ 5000HZ, and also can be choice low frequency: such as 0 ~ 1000HZ or 0 ~ 5000HZ.

Frequency output mode general can be used in control application, because it responses the percent flux. Users can choice pulse output when the equipment is applied to count.

7.3.2 Pulse Output Mode:

Pulse output mainly applies in count mode. A pulse output delegates a unit flux, such as 1L or 1M3 etc. Pulse output unit divide into 0.001L, 0.01L, 0.1L, 1L, 0.001M3, 0.01M3, 0.1M3, 1 M3, 0.001UKG, 0.01UKG, 0.1UKG, 1UKG, 0.001USG, 0.01USG, 0.1USG, 1USG. When users choice the pulse unit, they should notice the match of the flux range of flowmeter and pulse unit. For volume flux, count formula as follows:

$$Q_L = 0.0007854 \times D^2 \times V \text{ (L/S)}$$

$$O_r Q_M = 0.0007854 \times D^2 \times V \times 10^{-3} \text{ (M}^3\text{/S)}$$

Note: D-nozzle (mm)

V-velocity of flow (m/s)

The oversize flux and too small pulse unit will be made the pulse output over the up limit. Generally, pulse output should be controlled below 2000P/S. However, the too small flux and too large pulse unit will be made the instrument exports a pulse long time.

Otherwise, pulse output is different from frequency output. When pulse output cumulates a pulse unit, it exports a pulse. Therefore, pulse output is not equality. Generally, measure pulse output should choice count instrument, but not frequent instrument.

7.3.3 The Connection Of Digital Output

Digital output has three connected points: digital output connected point, digital ground point, and symbol as follows:

POUT ----- digital output point;

PCOM ----- digital ground point;

POUT is collector cut-off circuit output. Connect the line diagram as follows:

7.3.4 Digital Voltage Connect Mode

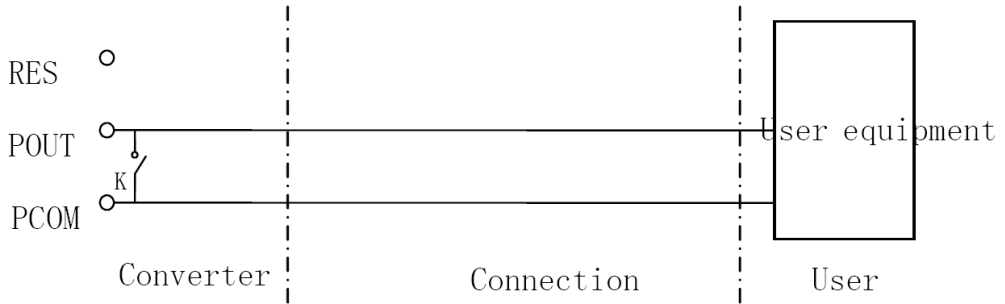

Fig. 8: (a) Digital connect voltage mode

7.3.5 Digital Current Connect Mode

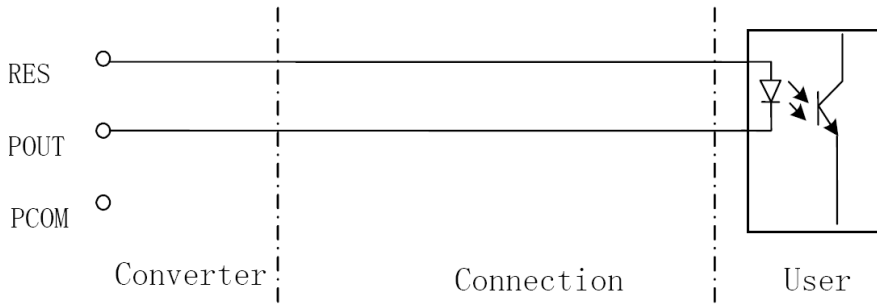

Fig. 8: (b) Digital current connect mode

7.3.6 DS Switch Connect Mode

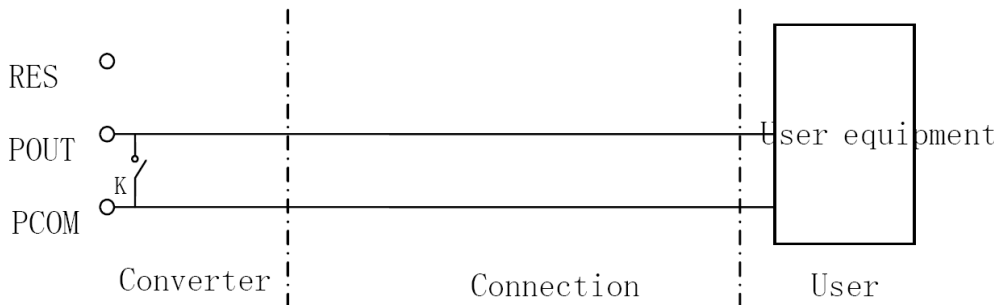

Fig. 8: (c) DS switch connect mode

DS output parameter table:

Parameter	Testing condition	Minimum	Type	maximal	Unit
Working voltage	IC=100 mA	3	24	36	V
Working current	Vol1.4V	0	300	350	mA
Working frequency	IC=100mA Vcc=24V	0	5000	7500	HZ
High voltage	IC=100mA	VCC	Vcc	Vcc	V
Low voltage	IC=100mA	0.9	1.0	1.4	V

Table: POUT Parameter

7.4 Simulated Data Output And Count

7.4.1 Simulation Signal Output

Simulation signal output can be separated two signals: 0~10mA, 4~20mA. User can select one when parameter setting.

Simulation signal output inner is 24V under 0~20mA, it can drive 750Ω resistance.

The percent flux of simulation signal output:

$$I_0 = (\text{Measure value} / \text{Full scale value}) \times \text{the scale of current} + \text{the zero point of current}$$

The current zero is 0 when 0~10mA, and the current zero is 4mA when 4~20mA.

It can be advanced simulation signal output distinguish. User can select the range of measure.

The manufacture’s parameter have been adjusted, it can’t need adjust. If have abnormality, it can consult 7.4.1.

7.4.2 Simulation Signal Output Adjust.

(1)The Converter adjust preparative

When the converter is running 15 minutes, the inner of converter becomes stabilization.

Preparative 0.1% amperemeter or 250Ω 0.1% voltage instrument.

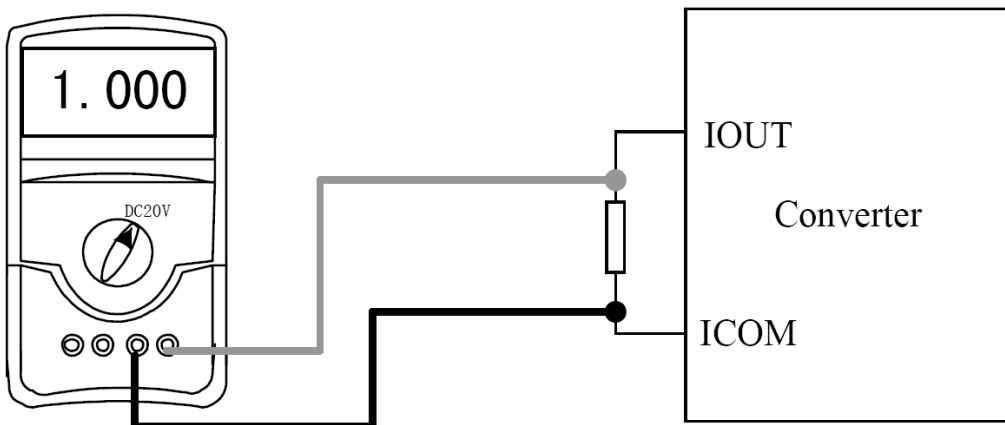

(2)Current zero correct

When the converter getting into parameter setting, selecting to “Current zero correct” and enter to it. The standard of signal fountain getting to “0”.Adjust parameter make amperemeter is 4mA (0.004mA).

(3)The full scale current correct

To select “current correct” to enter.Adjust the converter parameter make amperemeter is 20mA(0.004mA)

Adjust the current zero and the full range, the current function of the converter reached exactness.The line degree of current output of conversion should be controlled within the scope of 0.1%

(4) Current line degree checking

You can place the standard signal source in 75%50%25%,and check the line degree of current output

8. Setting Parameters

Converters can be operated in two ways:

1. Self-testing way
2. Parameters setting way

As soon as turning on the converter, it works in self-testing way doing all testing functions and displaying test data automatically. However, when it works in parameters testing way, parameters should be input by operators through keying three keys on its panel.

8.1 Function Keys

8.1.1 “Down” Key Function In Self- Testing Way

“Down” key: Selecting displayed data on lower line in turn;

“Enter” key: Press it to come into the picture of select function.

“Movie” key: It movies cursor left and right.

8.1.2 “Down” Key Function In Parameters Setting Way.

“Down” key: Subtract 1from the number at cursor area

“Up” key: Add 1 to the number at cursor area.

Push the “Movie” key and movie the cursor to the down of the “Up” key. Push the “Up” key and enter into the child menu.

Push the “Movie” key and movie the cursor to the down of the “Down” key. Push the “Down” key and return the parent menu.

8.2 Function Keys For Setting Parameters

To set or correct working parameters, the converter should be running in parameters setting way instead of measuring status.

In measuring status, click “Enter” keys getting to the select of parameter and transfer password

(0000), and then correct the password with one of the new passwords that are provided by manufacturer. Finally, push the “Enter” keys to work in Parameters Setting Way.

There are 6 Passwords in design and among them 4 for deferent operators in secret and 2 are fixed passwords for system operation.

8.2.1 The Picture Of Select Function

Press “Enter” key getting to the select of function picture. And Press it to select. There are 4 functions to selection.

Parameter code	Function content	Explain
1	Parameter code	Select this function It can be enter the picture of parameter.
2	Gross of hour	In this menu, It has gross of hour.
3	Broken electricity clock	In this menu, It has power cut function.
4	Gross reset	Select this functionIt can be gross reset operation.

8.2.1.1 Parameters Setting

Press “Enter” key, it displays “Parameters Setting” function. Input password. Press “movie” key, Movie cursor on the “Enter” key, Press it getting to Parameters Setting status.

8.2.1.2 Gross Reset

Press “Enter” key, and it displays “Parameters Setting” function. Press “Enter” key again. Turn over page to “Gross reset”. Input password of gross reset 00002.Press“Enter” key again, when “00002” change to “00000”.The reset function finished.

8.2.2. Parameters Setting Menu

There are 50 parameters for KFL-DC Series converter operation. All parameters can be set by users according to the users needs when the converters are running. The List of Parameters is shown below:

Setting Parameters in Menu

No.	Parameters and Words to be Set	Setting Way	Limits of Parameters	Grades
1	Language	Optional	Chinese or English	1
2	Com. Port	Can be set	0~99	2
3	Transfer Speed	Optional	300~19200	2
4	Pipe Diameter	Optional	3~3000	3
5	Flux unit	Optional	L/H, L/M, L/S, m ³ /H, m ³ /M, m ³ /S, UKG, USG	3
6	Measurement Range	Can be set	0~99999	3
7	Damping Time Measure	Optional	1~50	3
8	Opt of Flow Direction	Optional	Forward or Reverse	3
9	Correct Zero-flow	Can be set	0~±9999	3
10	Weak Signal Switch Off	Can be set	0~599.99%	3
11	Display Enable	Optional	Enable/Disable	3
12	Integrated Flow Unit	Optional	0.001m ³ -1m ³ , 0.001L-1L, 0.001UKG-1UKG, 0.001USG-1USG	3
13	Reverse measure permission	Optional	Enable/Disable	3
14	Type of Current Output	Optional	0~10mA /4~20mA	3
15	Form of Pulse Output	Optional	Frequency/Pulse	3
16	Pulse Unit Equivalent	Optional	0.001m ³ ~1m ³ 0.001L~1L0.001UKG~1UKG0.001USG~1USG	3
17	Limit of frequency Output	Optional	1~ 5999 HZ	3
18	Empty Pipe Alarm On	Optional	Enable/Disable	3
19	Empty Alarm Threshold	Can be set	599.99%	3
20	Range of Empty Pipe Test	Can be set	0.0000 ~5.9999	3
21	Upper Limit Alarm On	Optional	Enable/Disable	3
22	Value of Upper Limit Alarm	Can be set	000.0 ~ 599.99 %	3
23	Lower Limit Alarm On	Optional	Enable/Disable	3
24	Value of Lower Limit Alarm	Can be set	000.0 ~ 599.99 %	3
25	Sensor Code1	Set by User	Finished Y M0~99999	3
26	Sensor Code2	Set by User	Product Serial No.0~99999	3
27	Factors of Sensor	Can be set	0.0000 ~ 5.9999	3

28	Exciting Mode	Optional	Mode 1,2,3	3
29	Sensor constant	Can be set	1~9	3
30	Flow coefficients Verification	Can be set	0.0000 ~ 5.9999	3
31	Instrument coefficients count	Can be set	0.0000 ~ 5.9999	3
32	Lower Digits of Forward Total Flow	Correctable	00000~99999	4
33	Higher Digits of Forward Total Flow	Correctable	0000~9999	4
34	Lower Digits of Reverse Total Flow	Correctable	00000~99999	4
35	Higher Digits of Reverse Total Flow	Correctable	0000~9999	4
36	Date Year	Set by User	00~99	4
37	Date Month	Set by User	00~99	4
38	Date Day	Set by User	00~99	4
39	Time Hour	Set by User	00~99	4
40	Time Minute	Set by User	00~99	4
41	Time Second	Set by User	00~99	4
42	Password 1	Set by User	00000~99999	5
43	Password 2	Set by User	00000~99999	5
44	Password 3	Set by User	00000~99999	5
45	Password 4	Set by User	00000~99999	5
46	Zero-Current	Can be set	0.0000 ~ 1.9999	5
47	Full Scale of Current	Can be set	0.0000 ~ 3.9999	5
48	Verification Factors of Product	Can be set	0.00005.9999	5
49	Instrument Code1	Fixed	Finished Y M0~99999	6
50	Instrument Code2	Fixed	Product Serial No. 0~99999	6

9. Recording Time When Power Turn-Off (with Power Turn-Off Function)

There is a clock for timing when power turns off, and it can record 256 numbers of time. When the power turns off the form of displayed date is: from Year XXXX, month XX Day XX to XX Month XX Day. When 256 numbers have stored, the time will not recorded anymore.

9.1 Displaying Turn-off Power Time

Push down key “Enter” to enter the model “Displaying Turn-off Time”. Push “Up” key to display next recording and “Down” key to display preceding recording. Finally, push down the key “Exit” to re turn to “Flow Display Model”.

9.2 Erasing “Turn-Off Power” Recording

Holding down “Enter” key to enter the picture of instrument parameter setting and then enter “Input Password” model. After input “password 4+11”, and then hold down “SHIFT” key and push down “OK” key to erase the “Turn-Off Power” Recording.

10. Recording Gross of hour

Push down the “enter” button to enter the panel of the record of the total time, and then push down the ▲ key to show the record. The “increasing” button is used to show the next record and the “decreasing” button is used to show the former record, and push down the “exit” key to return to the “Display flux” mode.

To clear the record of the total time, and then the record of the total time is eliminated.

11. Infrared telecontrol function keys

The operation of the infrared-hand-remote control keyboard is the same with the operation of the instrument. When use it, please keep the infrared transmitter of the infrared-hand-remote control keyboard and the receiver of the instrument parallel, with the distance of about one meter.

Concrete operation referring to the figure:

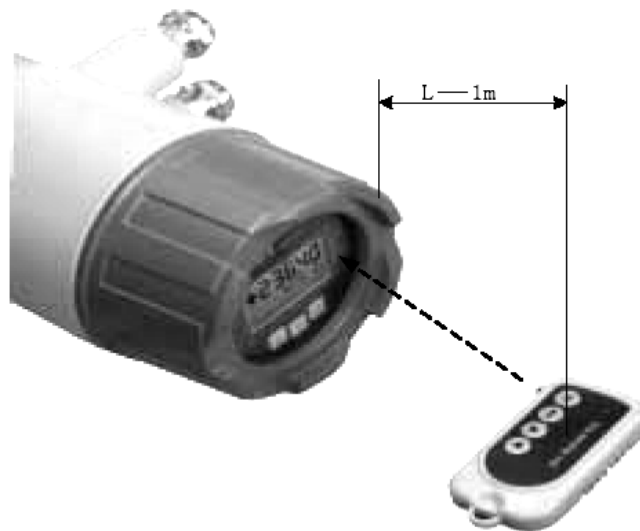

Fig. 9: The communication figure of the infrared-hand-remote control keyboard and the instrument

12. Alarm Information

Printed Circuit Board in converters is welded by means of surface welding techniques. Users are not able to repair converters by themselves. Therefore, the cases of converters can not be opened.

FQL: Upper Limit Alarm
FGP: Empty Pipe Alarm

FQL: Low Limit Alarm
SYS: Exciting Alarm

13. Installation

This section covers the steps required to physically install the flowtube. Instructions and procedures in this section may require special precautions to ensure the safety of the personnel performing the operations. Please refer to the following safety messages before performing any operation in this section.

! WARNING

Failure to follow these installation guidelines could result in death or serious injury: Installation and servicing instructions are for use by qualified personnel only. Performing any servicing other than that contained in this manual may result in death or serious injury. Do not perform any servicing other than that contained in the operating instructions, unless qualified.

! CAUTION

The flowtube liner is vulnerable to handling damage. Never place anything through the flowtube for the purpose of lifting or gaining leverage. Liner damage can render the flowtube useless.

! CAUTION

To avoid possible damage to the flowtube liner ends, do not use metallic or spiral-wound gaskets. If frequent removal is anticipated, take precautions to protect the liner ends. Short spool pieces attached to the flowtube ends are often used for protection.

! CAUTION

Correct flange bolt tightening is crucial for proper flowtube operation and life. All bolts must be tightened in the proper sequence to the specified torque limits. Failure to observe these instructions could result in severe damage to the flowtube lining and possible flowtube replacement.

13.1. Upstream and Downstream Piping

To ensure specification accuracy over widely varying process conditions, install the flowtube a minimum of five straight pipe diameters upstream and two pipe diameters downstream from the electrode plane (see Fig. 10).

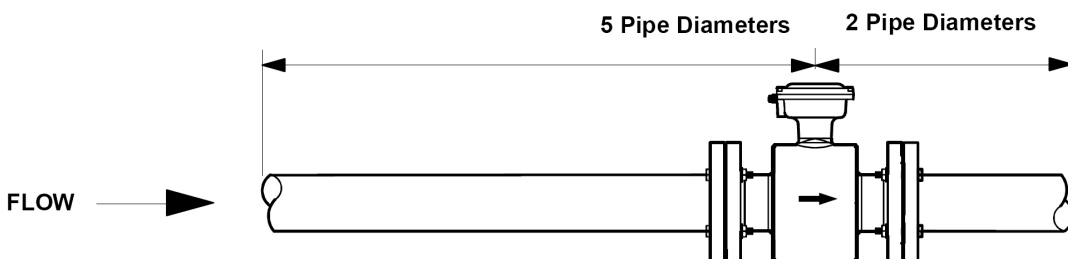

Fig. 10: Upstream and Downstream Straight Pipe Diameters

13.2 Flowtube Orientation

The flowtube should be installed in a position that ensures the flowtube remains full during operation. Horizontal or inclined positions are preferred. Fig. 11, Fig 12, and Fig. 13 show the proper flowtube orientation for the most common installations. The following orientations ensure that the electrodes are in the optimum plane to minimize the effects of entrapped gas. As illustrated in Fig. 12B and Fig. 13B, avoid downward flows where back pressure does not ensure that the flowtube remains full at all times.

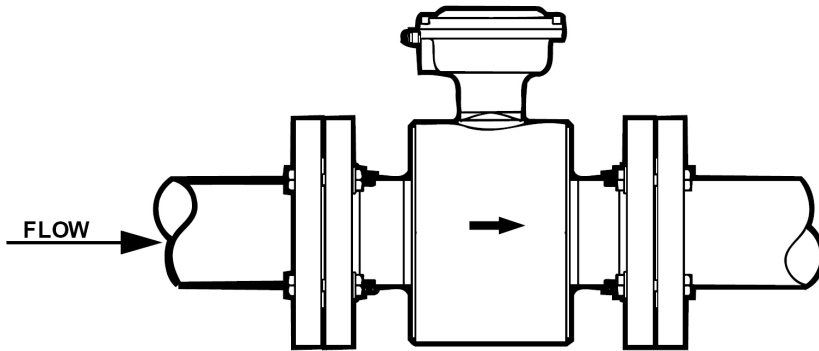

Fig. 11: Horizontal Flowtube Orientation

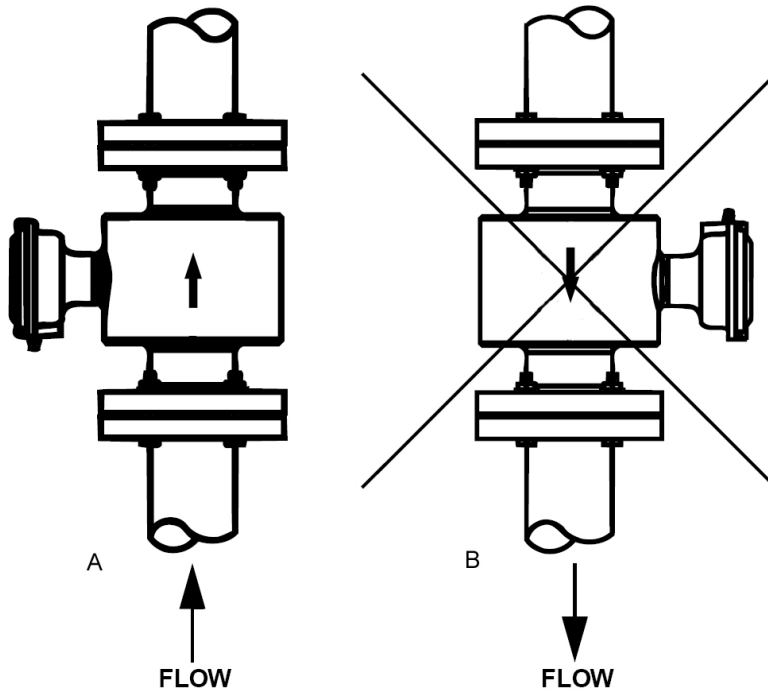

Fig. 12: Vertical Flowtube Orientation

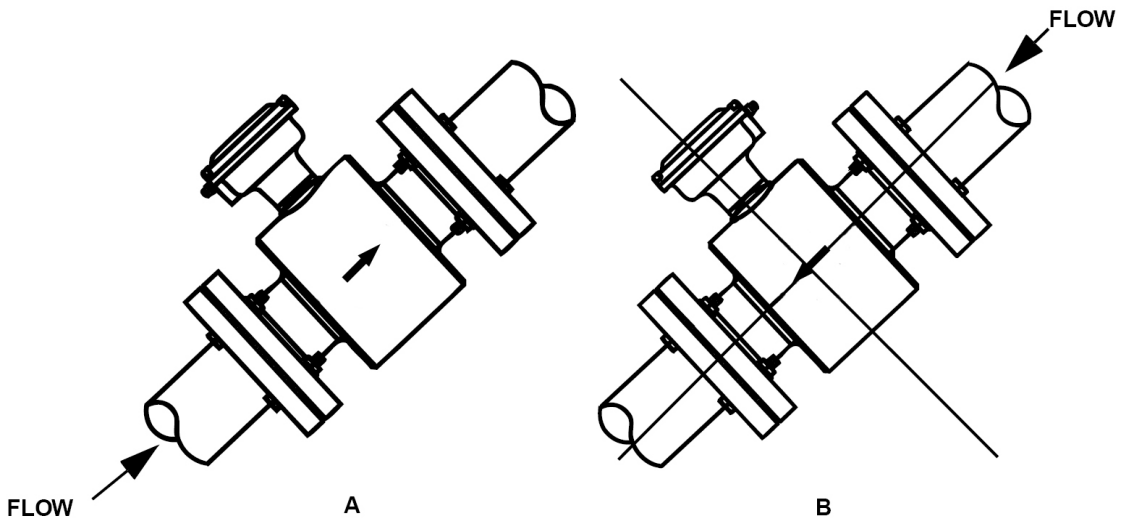

Fig. 13: Incline or Decline Orientation

13.3 Flow Direction

The flowtube should be mounted so that the FORWARD end of the flow arrow, shown on the flowtube identification tag, points in the direction of flow through the tube (see Figure 2-6). In this mounting configuration, the conduit ports point upstream.

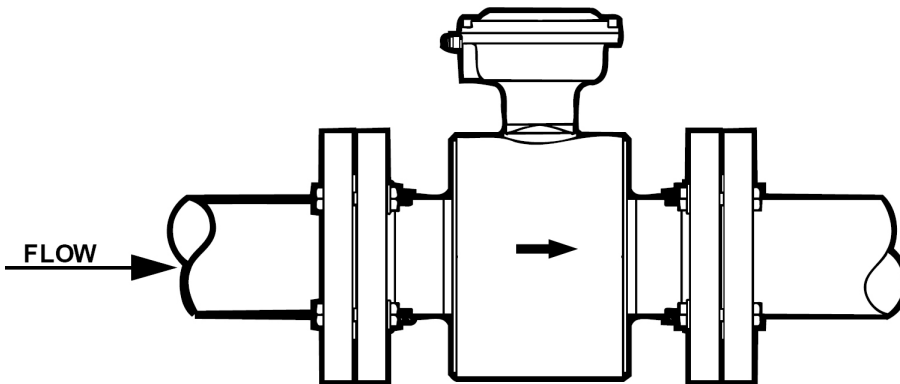

Fig. 14: Flow Direction

13.4 Grounding

Grounding the flowtube is one of the most important details of flowtube installation. Proper grounding ensures that only the voltage induced in the magnetic field of the flowtube is measured. Use Table 2-4 to

determine which grounding option to follow for proper installation. Attached grounding rings should be grounded equivalently to non-attached grounding rings.

The flowtube case should always be grounded in accordance with national and local electrical

codes. Failure to do so may impair the protection provided by the equipment. The most effective grounding method is direct connection to earth ground with minimal impedance.

Type of Pipe	Grounding of Options		
	No Grounding Options	Grounding Rings	Lining Protectors
Conductive Unlined Pipe	See Fig. 15	Not Required	See Fig. 16
Conductive Lined Pipe	Insufficient Grounding	See Fig. 16	See Fig. 16
Non-Conductive Pipe	Insufficient Grounding	See Fig. 17	See Fig. 17

Table: Grounding Installation

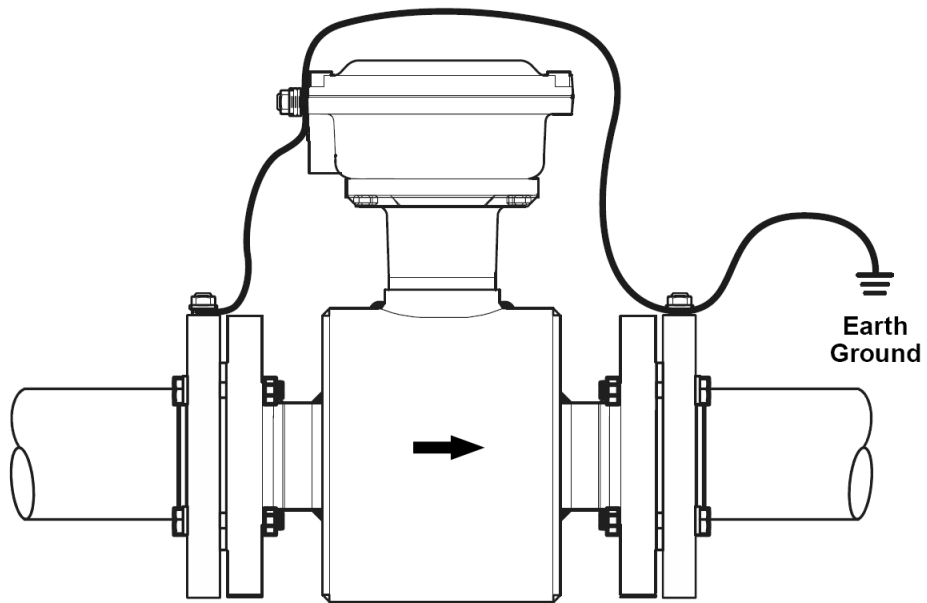

Fig. 15: No Grounding Options or Grounding Electrode in Lined Pipe

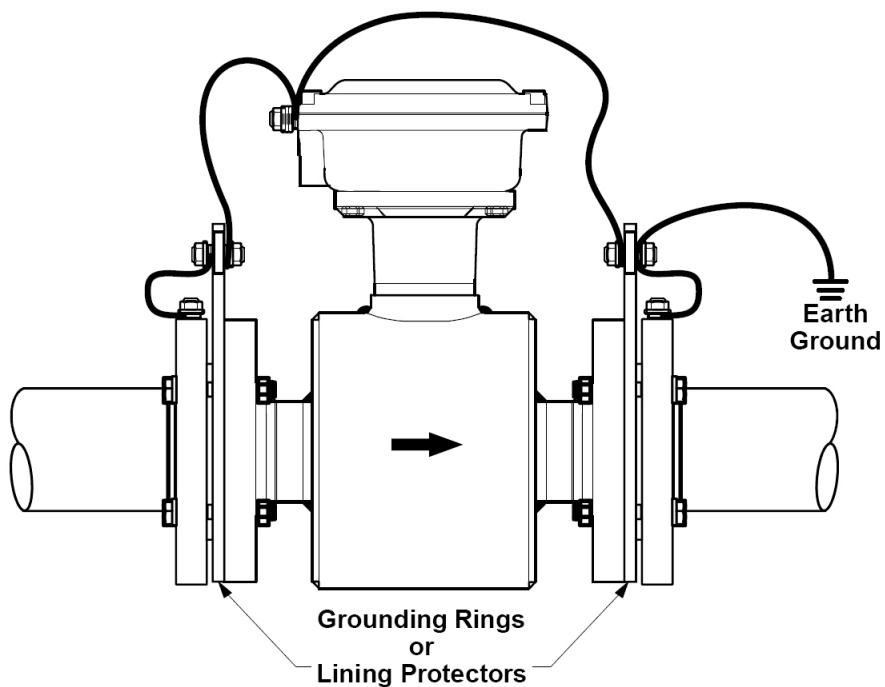

Fig. 16: Grounding with Grounding Rings or Lining Protectors

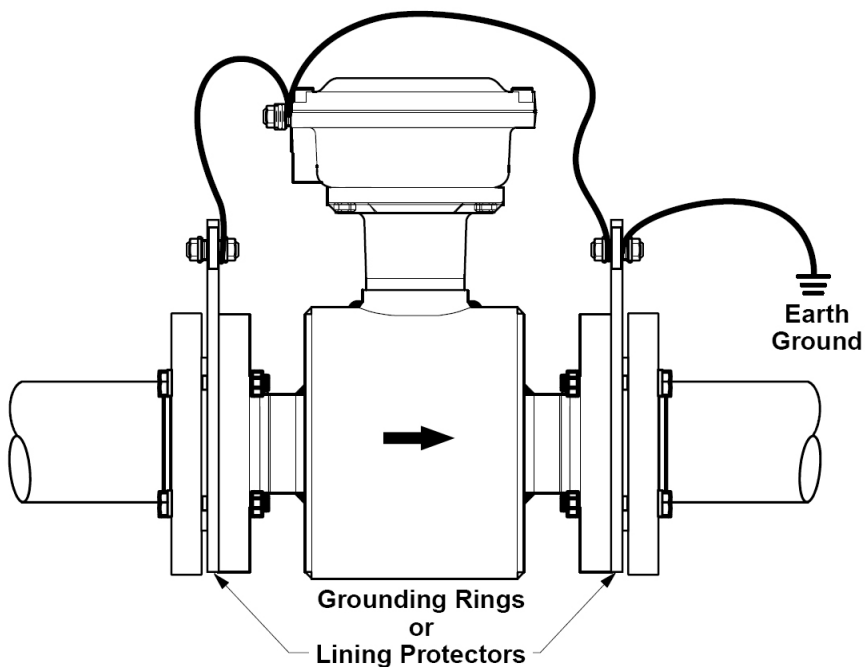

Fig. 17: Grounding with Grounding Rings or Lining Protectors

14. Troubleshooting

- 1) No Display:
 - a) Check the power supply connection;
 - b) Check the power fuse to see for OK;
 - c) Check the contrast of LCD and regulate it to working state;
- 2) Exciting Alarm
 - a) Check if the exciting cables EX1 and EX2 did not connected;
 - b) Check if the total resistance of sensor's exciting coil resistances less than 150Ω;
 - c) If a) and b) are OK, the converter is failed.
- 3) Empty Pipe Alarm
 - a) If measured fluid full of testing pipe of sensor;
 - b) When shorting circuit three connectors SIG 1, SIG 2, SIGGND of converter, and no "Empty Alarm" displayed then the converter works OK. In this case, it is possible that conductivity of measured fluid may be small or empty threshold of empty pipe and range of empty pipe are set wrongly.
 - c) Check if the signal cable is OK;
 - d) Check if the electro-poles are OK or not.
 - Let the flow is zero, then the displayed conductivity should be less than 100%.
 - Resistances of SIG1 to SIGGND and SIG2 to SIGGND are all less than 50kΩ (conductivity of water) during measurement operation. (It is better to test the resistances by means of multimeter with pointer to see the charging process well.)
 - e) The DC voltage should be less than 1V between DS1 and DS2 testing the voltage by means of multimeter. If DC voltage is larger than 1V, the electro poles of sensor were polluted that have to be cleaned.
- 4) Incorrect Measurement Of Flow
 - a) Check if the fluid full of testing pipe;
 - b) Check if the signal cable connection is right;
 - c) Check if the sensor coefficient and zero settings are no deferent from the data on the labels of product that are calibrated by manufacturer.

KFL**Wenzhou KFL Measuring & Controlling Instruments Co. Ltd.**

Mailbox No. 351, Yueqing, Zhejiang, China P.C.: 325600

Tel. +86-(0)577-62566951

Fax +86-(0)577-62569171

<http://www.kafon.com.cn>

Rights reserved to make technical revisions.

KFL®

Wenzhou KAFLON Measuring & Controlling INSTRUMENTS CO.,LTD

Yueqing, Zhejiang, China, P.C. 325600

Tel: +86-(0)577-62566951

Fax: +86-(0)577-62569171

Email: Kaflon@gmail.com

Website: [Http://www.kaflon.com.cn](http://www.kaflon.com.cn)