



## 1204 Terminator (Class 1, Division 2) (Catalog Number 1204-TFA1, 1204-TFB2)

### Where this Option is Used

The 1204 Terminator Option can be installed in most adjustable frequency AC drive applications to increase protection of the AC motor. The option is designed to be used with Allen-Bradley Adjustable frequency AC drives. When installed at the motor terminals, the terminator can reduce potentially destructive reflected wave spikes that can occur with long motor leads.

### What this Option Contains

The Terminator Option contains the terminator device with an attached 3 meter (10 feet) standard 4 wire 3mm<sup>2</sup> (12 gauge) connection cable.

### What these Instructions Contain

These instructions contain the information you need to properly install the Terminator Option. Recommended mounting, connecting, and grounding procedures are included. Major topics and page numbers are listed below.

Catalog Number Description	1
Dimensions, Weights and Cable Locations	2
Specifications	3
Heat Dissipation	3
Determining the Maximum Cable Length for Your System	4
Installation	7
Drive Programming	9
Grounding	9
Maintenance	10

### Catalog Number Description

The following table provides information about the catalog number for the Terminator Option:

1204		-T		F		B2			
<i>First Position</i>		<i>Second Position</i>		<i>Third Position</i>		<i>Fourth Position</i>			
Bulletin No.		Type		NEMA Rating		Voltage Rating & Size			
<u>Description</u>		<u>Letter</u>	<u>Description</u>	<u>Letter</u>	<u>Description</u>	<u>Code</u>	<u>Voltage Rating</u>	<u>Drive kW (HP)<sup>1</sup></u>	<u>Maximum Allowable Drive Carrier Frequency</u>
Bulletin Number		T	Terminator	F	NEMA Type 4	A1	380-600V	0.37-3.7 (0.5-5)	6 kHz
						B2	380-600V	1.5-597 (2.0-800)	2 kHz

<sup>1</sup> Refer to the maximum cable length tables on pages 4 through 6.

### Dimensions, Weights and Cable Locations

Refer to the following diagram for terminator dimensions and cable locations. The dimensions are given in millimeters and (inches). The terminator weighs 3.86 kilograms (8.5 pounds).

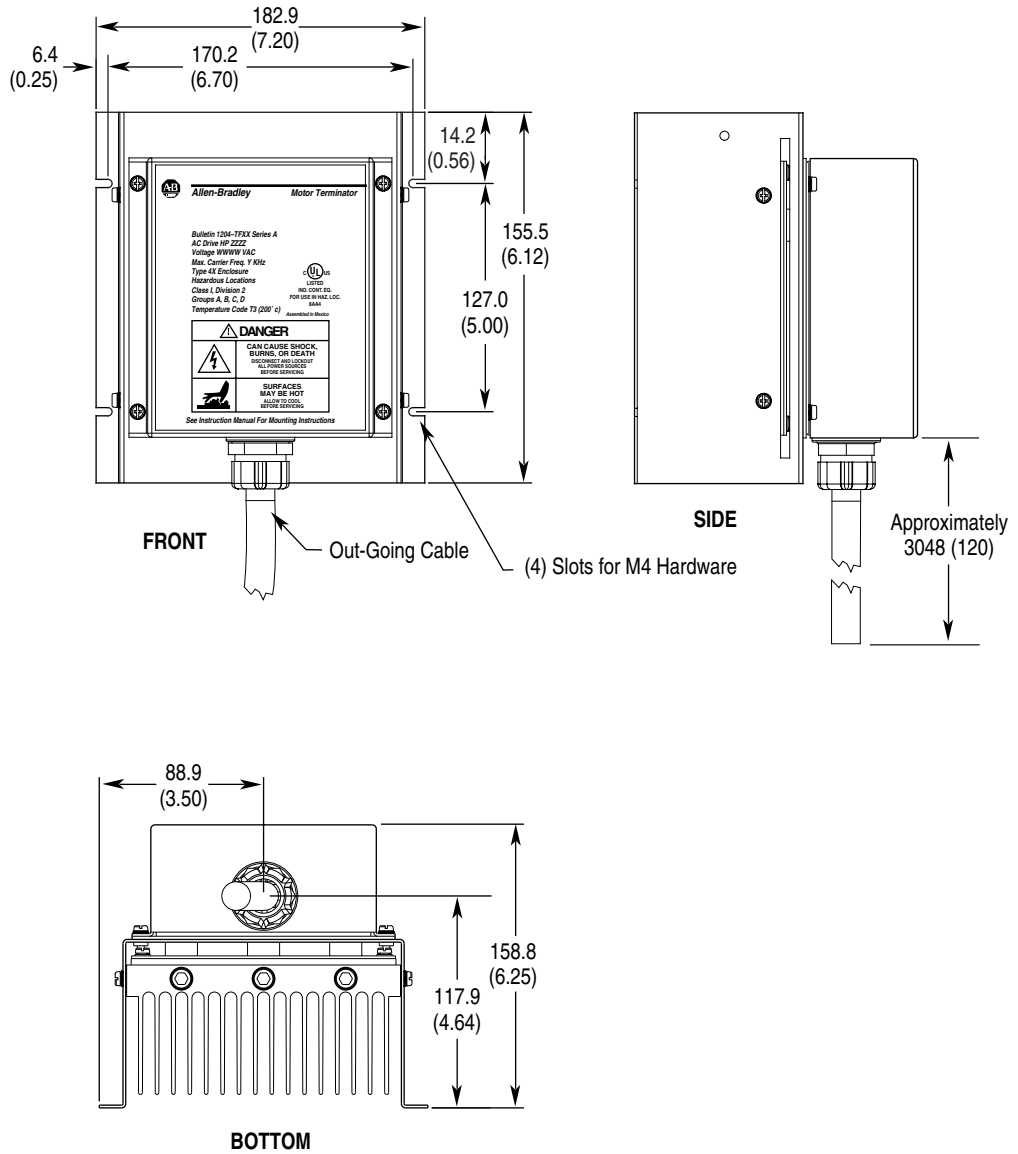

## Specifications

The following specifications are provided for the Terminator Option.

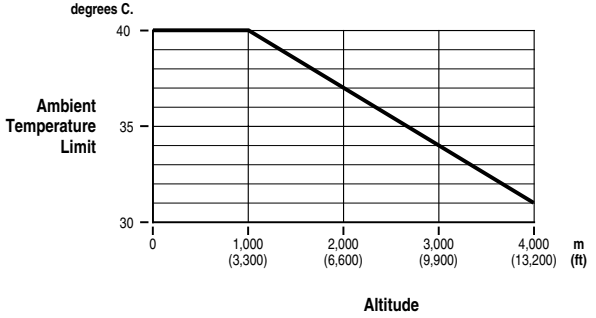
Category	Specifications
Input power	380-600V, Three-Phase
Maximum Drive Carrier Frequency <sup>1</sup>	TFA1 – 6 kHz TFB2 – 2 kHz Refer to “ <i>Drive Programming</i> ” on page 9 for additional information.
Ambient temperature	0-40 degrees C (32-104 degrees F)
Humidity	5-95% non-condensing
Atmosphere	Class 1, Division 2
Heat dissipation <sup>1</sup>	Refer to the heat dissipation table below.
Enclosure type	IP65 (NEMA Type 4x)
Hazardous Environment Rating	T3 (200° C); Groups A, B, C, D
Agency certification	U.L., C-UL
Altitude derating	Full rating 0-1000 meters (0-3280 feet) 

<sup>1</sup> The drive PWM carrier frequency that you choose affects the heat dissipation and the surface temperature of the terminator.

## Heat Dissipation

This chart is based on an ambient temperature of 45 degrees C.

Drive Frequency	Length <i>meters (feet)</i>	1204-TFA1 Terminator				1204-TFB2 Terminator			
		460 Volts + 10%		600 Volts + 10%		460 Volts + 10%		600 Volts + 10%	
		Watts	Heatsink°	Watts	Heatsink°	Watts	Heatsink°	Watts	Heatsink°
6 kHz	91 (300)	210W	142° C	220W	150° C	Must Use 2 kHz			
	183 (600)	250W	160° C	260W	169° C				
4 kHz	91 (300)	170W	125° C	180W	133° C				
	183 (600)	180W	130° C	210W	138° C				
2 kHz	91 (300)	80W	81° C	100W	95° C	200W	139° C	290W	182° C
	183 (600)	90W	88° C	140W	104° C	250W	160° C	360W	200° C

## Determining the Maximum Cable Length for Your System

Use the following tables to determine the maximum cable length for your system.

The values shown are for nominal input voltage and a drive carrier frequency of 2 kHz. If you plan to operate your system at carrier frequencies above 2 kHz, refer to the heat dissipation table on page 3. If you plan to operate your system above the levels listed in the heat dissipation table, consult the factory.

If you are running at high-line conditions (nominal line + 10%), multiply the values by 0.85.

### 1305 Drive Maximum Motor Cable Length Restrictions

Lengths are given in meters and (feet)

Drive HP (460V)	Motor HP (460V)	w/ 1204-TFB2 Terminator		w/ 1204-TFA1 Terminator				With Allen-Bradley 1329R/L Motors
		Motor Type		Motor Type				
		A or B		A		B		
		Cable Type		Cable Type		Cable Type		
		Shielded	Unshielded	Shielded	Unshielded	Shielded	Unshielded	
0.5	0.5	NR	NR	NR	NR	NR	NR	For applications/ installations using new motors, no restrictions in lead length due to voltage reflection are necessary. You should observe standard practices for voltage drop, cable capacitance, and other issues.
1	0.5	NR	NR	76 (250)	61 (200)	76 (250)	121 (400)	
	1	NR	NR	45 (150)	61 (200)	45 (150)	76 (250)	
2	0.5	91 (300)	121 (400)	99 (325)	61 (200)	152 (500)	121 (400)	
	1	61 (200)	61 (200)	99 (325)	61 (200)	121 (400)	121 (400)	
	2	NR	NR	91 (300)	61 (200)	91 (300)	121 (400)	
3	1	91 (300)	182 (600)	99 (325)	61 (200)	182 (600)	121 (400)	
	2	91 (300)	121 (400)	99 (325)	61 (200)	152 (500)	121 (400)	
	3	NR	NR	91 (300)	61 (200)	91 (300)	121 (400)	
5	2	121 (400)	182 (600)	99 (325)	61 (200)	182 (600)	121 (400)	
	3	91 (300)	121 (400)	99 (325)	61 (200)	152 (500)	121 (400)	
	5	NR	NR	91 (300)	61 (200)	91 (300)	121 (400)	

NR = Not Recommended.

**Type A Motor Characteristics:** No phase paper or misplaced phase paper, lower quality insulation systems, corona inception voltages between 850 and 1000 volts.

**Type B Motor Characteristics:** Properly placed phase paper, medium quality insulation systems, corona inception voltages between 1000 and 1200 volts.

**1329R/L Motors:**

These AC variable speed motors are "Power Matched" for use with Allen-Bradley drives. Each motor is energy efficient and designed to meet or exceed the requirements of the Federal Energy Act of 1992. All 1329R/L motors are optimized for variable speed operation and include premium inverter grade insulation systems which meet or exceed NEMA MG1, Part 31.40.4.2.

**1336 PLUSPLUS II/IMPACT™/FORCE**  
**Maximum Motor Cable Length Restrictions (380-480 Volt Drives)<sup>1</sup>**

Lengths are given in meters and (feet)

Drive Frame	Drive kW (HP)	Motor kW (HP)	w/1204-TFB2 Terminator		w/1204-TFA1 Terminator				With Allen-Bradley 1329R/L Motors		
			Motor Type		Motor Type						
			A or B		A		B				
			Cable Type		Cable Type		Cable Type				
				Shld. <sup>2</sup>	Unshld.	Shld. <sup>2</sup>	Unshld.	Shld. <sup>2</sup>	Unshld.		
A1	0.37 (0.5)	0.37 (0.5)	Use 1204-TFA1 Terminator or 1329R/L Motor		30.5 (100)	61.0 (200)	30.5 (100)	61.0 (200)	For applications/ installations using new motors, no restrictions in lead length due to voltage reflection are necessary. You should observe standard practices for voltage drop, cable capacitance, and other issues.		
	0.75 (1)	0.75 (1)			30.5 (100)	30.5 (100)	30.5 (100)	30.5 (100)			
	0.75 (1)	0.37 (0.5)			30.5 (100)	61.0 (200)	30.5 (100)	61.0 (200)			
A2	1.2 (1.5)	1.2 (1.5)	Use 1204-TFB2 Terminator or 1329R/L Motor		30.5 (100)	30.5 (100)	61.0 (200)	61.0 (200)			
		0.75 (1)			30.5 (100)	30.5 (100)	61.0 (200)	61.0 (200)			
		0.37 (0.5)			30.5 (100)	30.5 (100)	61.0 (200)	61.0 (200)			
	1.5 (2)	1.5 (2)			91.4 (300)	91.4 (300)	30.5 (100)	30.5 (100)		91.4 (300)	61.0 (200)
		1.2 (1.5)			91.4 (300)	182.9 (600)	30.5 (100)	30.5 (100)		91.4 (300)	61.0 (200)
		0.75 (1)			182.9 (600)	182.9 (600)	30.5 (100)	30.5 (100)		91.4 (300)	61.0 (200)
		0.37 (0.5)			182.9 (600)	182.9 (600)	30.5 (100)	30.5 (100)		91.4 (300)	61.0 (200)
2.2 (3)	2.2 (3)	182.9 (600)	182.9 (600)	Use 1204-TFB2 Terminator or 1329R/L Motor							
	1.5 (2)	182.9 (600)	182.9 (600)								
	0.75 (1)	182.9 (600)	182.9 (600)								
	0.37 (0.5)	182.9 (600)	182.9 (600)								
A3	3.7 (5)	3.7 (5)	182.9 (600)	182.9 (600)	Use 1204-TFB2 Terminator or 1329R/L Motor						
		2.2 (3)	182.9 (600)	182.9 (600)							
		1.5 (2)	182.9 (600)	182.9 (600)							
		0.75 (1)	182.9 (600)	182.9 (600)							
		0.37 (0.5)	182.9 (600)	182.9 (600)							
A4	5.5-7.5 (7.5-10)	5.5-7.5 (7.5-10)	182.9 (600)	182.9 (600)							
B	5.5-22 (7.5-30)	5.5-22 (7.5-30)	182.9 (600)	182.9 (600)							
C	30-45 (X40-X60)	30-45 (40-60)	182.9 (600)	182.9 (600)							
D	45-112 (60-X150)	45-112 (60-150)	182.9 (600)	182.9 (600)							
E	112-187 (150-250)	112-224 (150-300)	182.9 (600)	182.9 (600)							
F	187-336 (250-450)	187-336 (250-450)	182.9 (600)	182.9 (600)							
G	187-448 (X250-600)	187-448 (250-600)	182.9 (600)	182.9 (600)							
H	552-597 (700-800)	522-597 (700-800)	182.9 (600)	182.9 (600)							

NR = Not Recommended

<sup>1</sup> Values shown are for 480V nominal input voltage and drive carrier frequency of 2 kHz. Consult factory regarding operation at carrier frequencies above 2 kHz. Multiply values by 0.85 for high line conditions. For input voltages of 380, 400 or 415V AC, multiply the table values by 1.25, 1.20 or 1.15, respectively.

<sup>2</sup> Includes wire in conduit.

**Type A Motor Characteristics:** No phase paper or misplaced phase paper, lower quality insulation systems, corona inception voltages between 850 and 1000 volts.

**Type B Motor Characteristics:** Properly placed phase paper, medium quality insulation systems, corona inception voltages between 1000 and 1200 volts.

**1329R/L Motors:** These AC variable speed motors are "Power Matched" for use with Allen-Bradley drives. Each motor is energy efficient and designed to meet or exceed the requirements of the Federal Energy Act of 1992. All 1329R/L motors are optimized for variable speed operation and include premium inverter grade insulation systems which meet or exceed NEMA MG1, Part 31.40.4.2.

**1336 PLUS/PLUS II/IMPACT™/FORCE**  
**Maximum Motor Cable Length Restrictions (500-600 Volt Drives)<sup>1</sup>**

Lengths are given in meters and (feet)

Drive Frame	Drive kW (HP)	Motor kW (HP)	w/1204-TFB2 Terminator			w/1204-TFA1 Terminator		With Allen-Bradley 1329R/L Motors
			Motor Type			Motor Type		
			A	B	1329R/L	A	B	
			<i>Any Cable</i>	<i>Any Cable</i>	<i>Any Cable</i>	<i>Any Cable</i>	<i>Any Cable</i>	
A4	0.75 (1)	0.75 (1)	NR	182.9 (600)	335.3 (1100)	NR	61.0 (200)	182.9 (600)
		0.37 (0.5)	NR	182.9 (600)	335.3 (1100)	NR	61.0 (200)	182.9 (600)
	1.5 (2)	1.5 (2)	NR	182.9 (600)	335.3 (1100)	NR	61.0 (200)	182.9 (600)
		1.2 (1.5)	NR	182.9 (600)	335.3 (1100)	NR	61.0 (200)	182.9 (600)
		0.75 (1)	NR	182.9 (600)	335.3 (1100)	NR	61.0 (200)	182.9 (600)
		0.37 (0.5)	NR	182.9 (600)	335.3 (1100)	NR	61.0 (200)	182.9 (600)
	2.2 (3)	2.2 (3)	NR	182.9 (600)	335.3 (1100)	NR	61.0 (200)	182.9 (600)
		1.5 (2)	NR	182.9 (600)	335.3 (1100)	NR	61.0 (200)	182.9 (600)
		0.75 (1)	NR	182.9 (600)	335.3 (1100)	NR	61.0 (200)	182.9 (600)
		0.37 (0.5)	NR	182.9 (600)	335.3 (1100)	NR	61.0 (200)	182.9 (600)
	3.7 (5)	3.7 (5)	NR	182.9 (600)	335.3 (1100)	NR	61.0 (200)	182.9 (600)
		2.2 (3)	NR	182.9 (600)	335.3 (1100)	NR	61.0 (200)	182.9 (600)
		1.5 (2)	NR	182.9 (600)	335.3 (1100)	NR	61.0 (200)	182.9 (600)
		0.75 (1)	NR	182.9 (600)	335.3 (1100)	NR	61.0 (200)	182.9 (600)
		0.37 (0.5)	NR	182.9 (600)	335.3 (1100)	NR	61.0 (200)	182.9 (600)
	B	5.5-15 (7.5-20)	5.5-15(7.5-20)	91.4 (300)	182.9 (600)	2	NR	61.0 (200)
C	18.5-45 (25-60)	18.5-45 (25-60)	91.4 (300)	182.9 (600)	2	NR	61.0 (200)	182.9 (600)
D	56-93 (75-125)	56-93 (75-125)	91.4 (300)	182.9 (600)	2	NR	61.0 (200)	182.9 (600)
E	112-224 (150-X300)	112-224 (150-X300)	91.4 (300)	182.9 (600)	2	NR	61.0 (200)	182.9 (600)
F	187-336 (250-450)	187-336 (250-450)	91.4 (300)	182.9 (600)	2	NR	61.0 (200)	182.9 (600)
G	224-448 (300-600)	224-448 (300-600)	91.4 (300)	182.9 (600)	2	NR	61.0 (200)	182.9 (600)
H	522-597 (700-800)	522-597 (700-800)	91.4 (300)	182.9 (600)	2	NR	61.0 (200)	182.9 (600)

NR = Not Recommended

<sup>1</sup> Values shown are for nominal input voltage and drive carrier frequency of 2 kHz. Consult factory regarding operation at carrier frequencies above 2 kHz. Multiply values by 0.85 for high line conditions.

<sup>2</sup> Information not available at time of printing.

**Type A Motor Characteristics:** No phase paper or misplaced phase paper, lower quality insulation systems, corona inception voltages between 850 and 1000 volts.

**Type B Motor Characteristics:** Properly placed phase paper, medium quality insulation systems, corona inception voltages between 1000 and 1200 volts.

**1329R/L Motors:** These AC variable speed motors are "Power Matched" for use with Allen-Bradley drives. Each motor is energy efficient and designed to meet or exceed the requirements of the Federal Energy Act of 1992. All 1329R/L motors are optimized for variable speed operation and include premium inverter grade insulation systems which meet or exceed NEMA MG1, Part 31.40.4.2.

## PowerFlex 70/700/700H

See the PowerFlex Reference Manual, Volume 1, publication PFLEX-RM001 available online at [www.rockwellautomation.com/literature](http://www.rockwellautomation.com/literature).

## PowerFlex 700S

See the PowerFlex Reference Manual, Volume 2, publication PFLEX-RM002 available online at [www.rockwellautomation.com/literature](http://www.rockwellautomation.com/literature).

## Installation

Installation of the 1204 Terminator must be in accordance with Class I, Division 2 wiring methods as defined in Article 501-4(b) of the National Electrical Code, NFPA 70 for installations within the United States, or as specified in Section 18-152 of the Canadian Electrical Code for installation within Canada.



### WARNING: EXPLOSION HAZARD

- Substitution of components may impair suitability for Class I, Division 2.
- When in hazardous locations, turn off power before replacing or wiring modules.
- Do not disconnect equipment unless power has been switched off or the area is known to be nonhazardous.

To install the terminator, follow these steps:

1. Remove all power connected to the system.



**ATTENTION:** Electric shock can cause injury or death. Remove all power before working with this product. Verify that the voltage on the bus capacitors has discharged. Measure the DC bus voltage at the + and – terminals of TB1. The voltage must be zero.

**ATTENTION:** The terminator surfaces may be hot enough to cause serious burns. You should take this into consideration when deciding where to mount your terminator.

2. Mount the terminator on a metal surface.

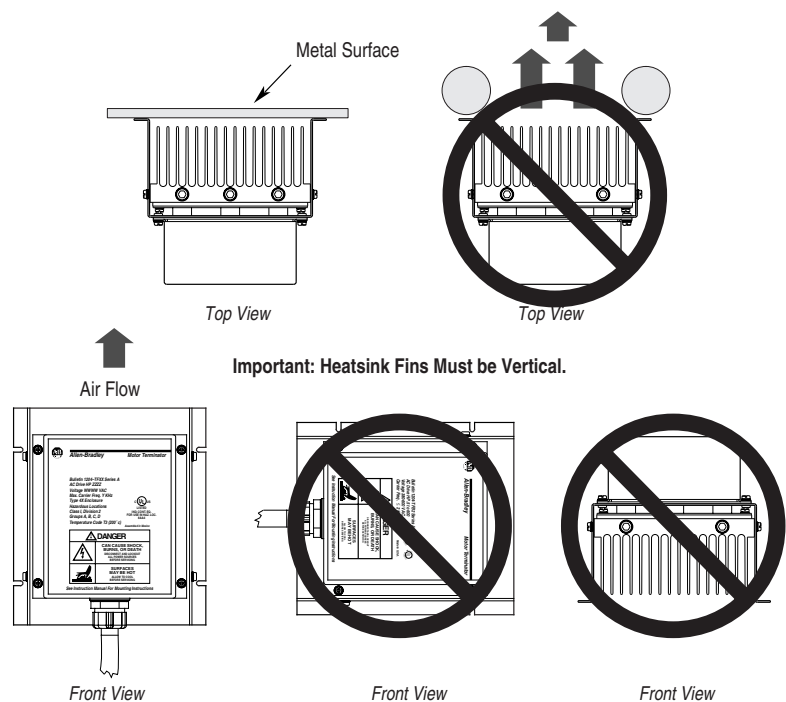

3. You must allow at least 152.4 mm (6 in.) on each side of the unit and 304.8 mm (12 in.) on the top and bottom of the unit for proper air circulation.

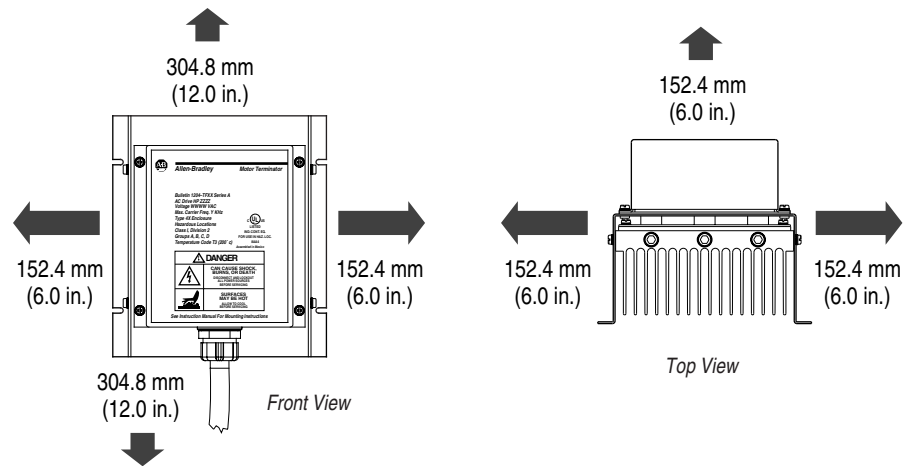

**ATTENTION:** The terminator surfaces may be hot enough to cause serious burns. If your system consistently runs at line voltages above nominal, you should place a shroud around the terminator to prevent accidental exposure.

4. If your system consistently runs at line voltages above nominal and you are mounting the terminator in a high-traffic area where the potential for contact is high, you should place a shroud of expanded metal or mesh screen around the terminator. The shroud should not restrict air flow to the terminator, nor should it be closer than 152.4 mm (6 in.) to the terminator at any point.

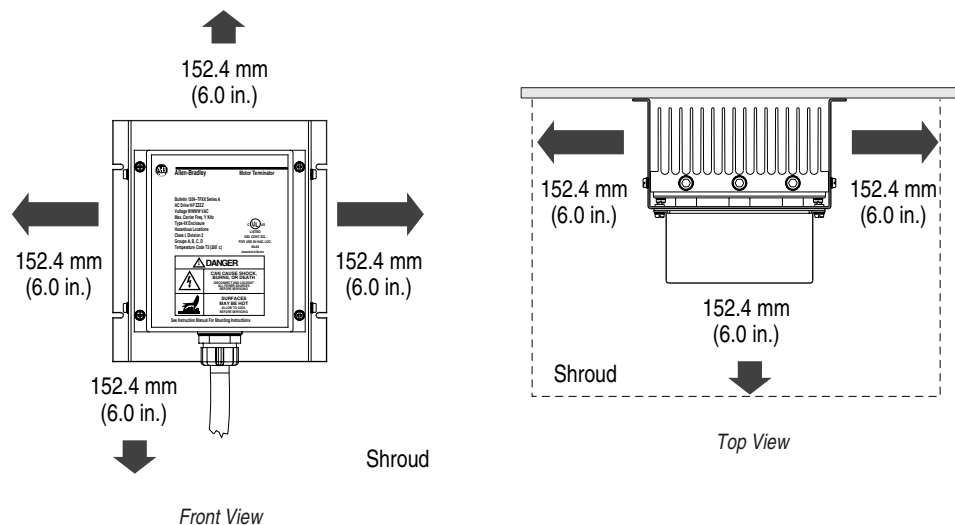

5. Connect the red, white and black cable conductors to the corresponding three-phase motor leads/terminals.
6. Attach the green cable conductor to the motor ground that is connected directly to the drive PE terminal.



## Drive Programming

If the default PWM frequency is greater than the maximum drive carrier frequency listed on page 3, you must re-program the drive to a value that is less than or equal to the maximum drive carrier frequency.

## Grounding

Follow the recommended grounding practices provided in your drive User Manual. The following illustration shows an example of the system grounding practices.

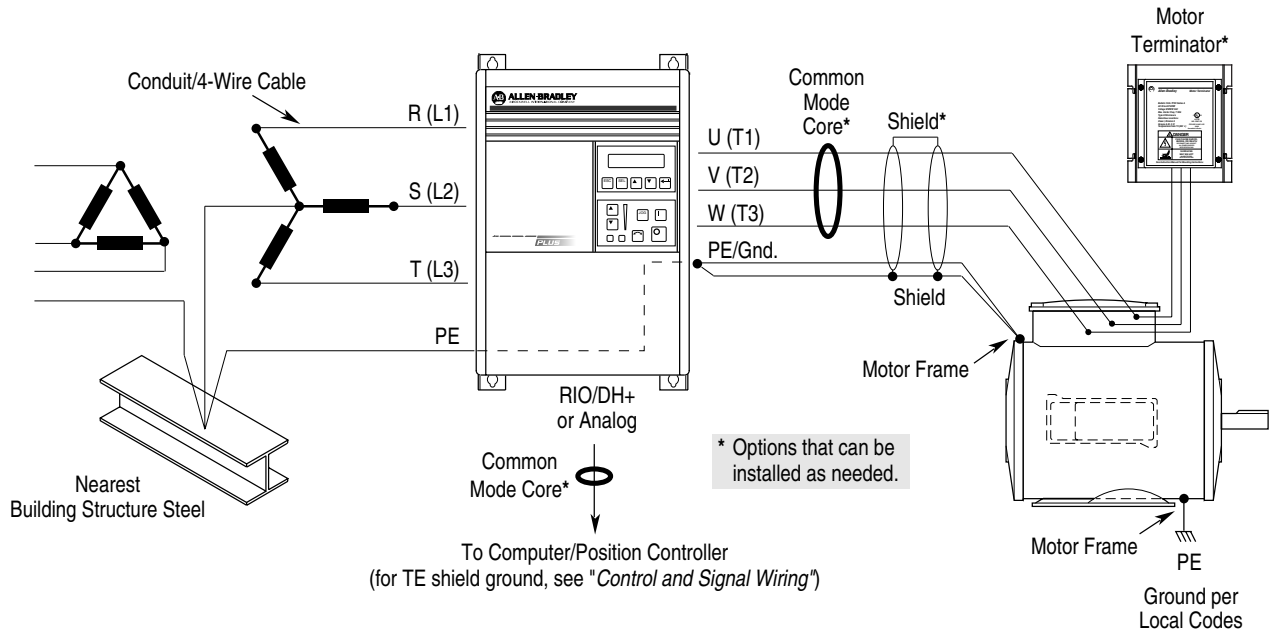

**Important:** If you cannot connect the terminator directly to the motor mounted junction box, an auxiliary junction box can be used. However, the terminator-to-motor connection length should be no more than 6 meters (20 feet). If installed in hazardous location, an auxiliary junction box rated Class 1, Division 2 must be used.



**ATTENTION:** The National Codes and standards (NEC, VDE, BSI, etc.) and local codes outline provisions for safely installing electrical equipment. Installation must comply with specifications regarding wire types, conductor sizes, branch circuit protection, and disconnect devices. Failure to do so may result in personal injury and/or equipment damage.

You can power up the system once proper installation, drive programming, and grounding is completed.

**Maintenance**

The terminator does not require routine maintenance. However, you should periodically remove dust to allow for maximum cooling efficiency.

---



**ATTENTION:** Electric shock can cause injury or death. Remove all power before touching the terminator.



**ATTENTION:** The terminator surfaces may be hot enough to cause serious burns. Allow the terminator time to cool down before touching any surface.

---

## Notes

[www.rockwellautomation.com](http://www.rockwellautomation.com)

---

**Power, Control and Information Solutions Headquarters**

Americas: Rockwell Automation, 1201 South Second Street, Milwaukee, WI 53204 USA, Tel: (1) 414.382.2000, Fax: (1) 414.382.4444

Europe/Middle East/Africa: Rockwell Automation, Vorstlaan/Boulevard du Souverain 36, 1170 Brussels, Belgium, Tel: (32) 2 663 0600, Fax: (32) 2 663 0640

Asia Pacific: Rockwell Automation, Level 14, Core F, Cyberport 3, 100 Cyberport Road, Hong Kong, Tel: (852) 2887 4788, Fax: (852) 2508 1846