



## **Saturno Super/Junior Operating Procedures**

**REA North America**

# REA - Saturno Junior and Super Models SPECIFICATIONS

Model	Voltage	Current	Steam Production	Boiler Temp.	Temp. @ Tool Nozzle	Water Consumption	Hose Length	Warm up Time	Dimensions	Weight
Junior										
Super										

# REA - Saturno Junior and Super Models

## INTRODUCTION

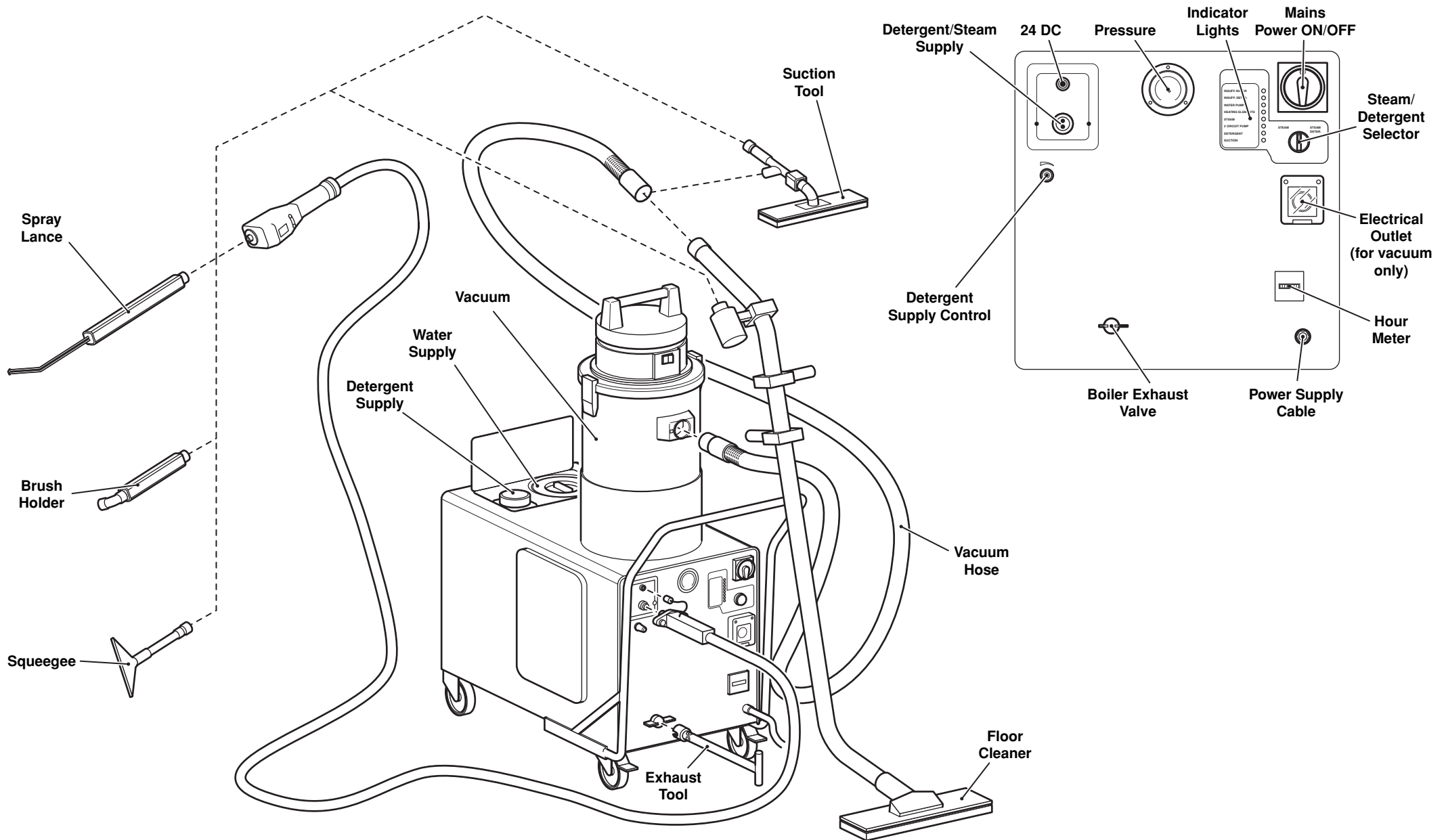

# REA - Saturno Junior and Super Models HAZARDS

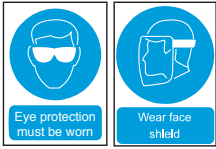

Wear Safety Glasses or Face Shield

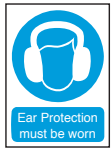

Wear Ear Protection



Wear Gloves



Safety Shoes/Boots

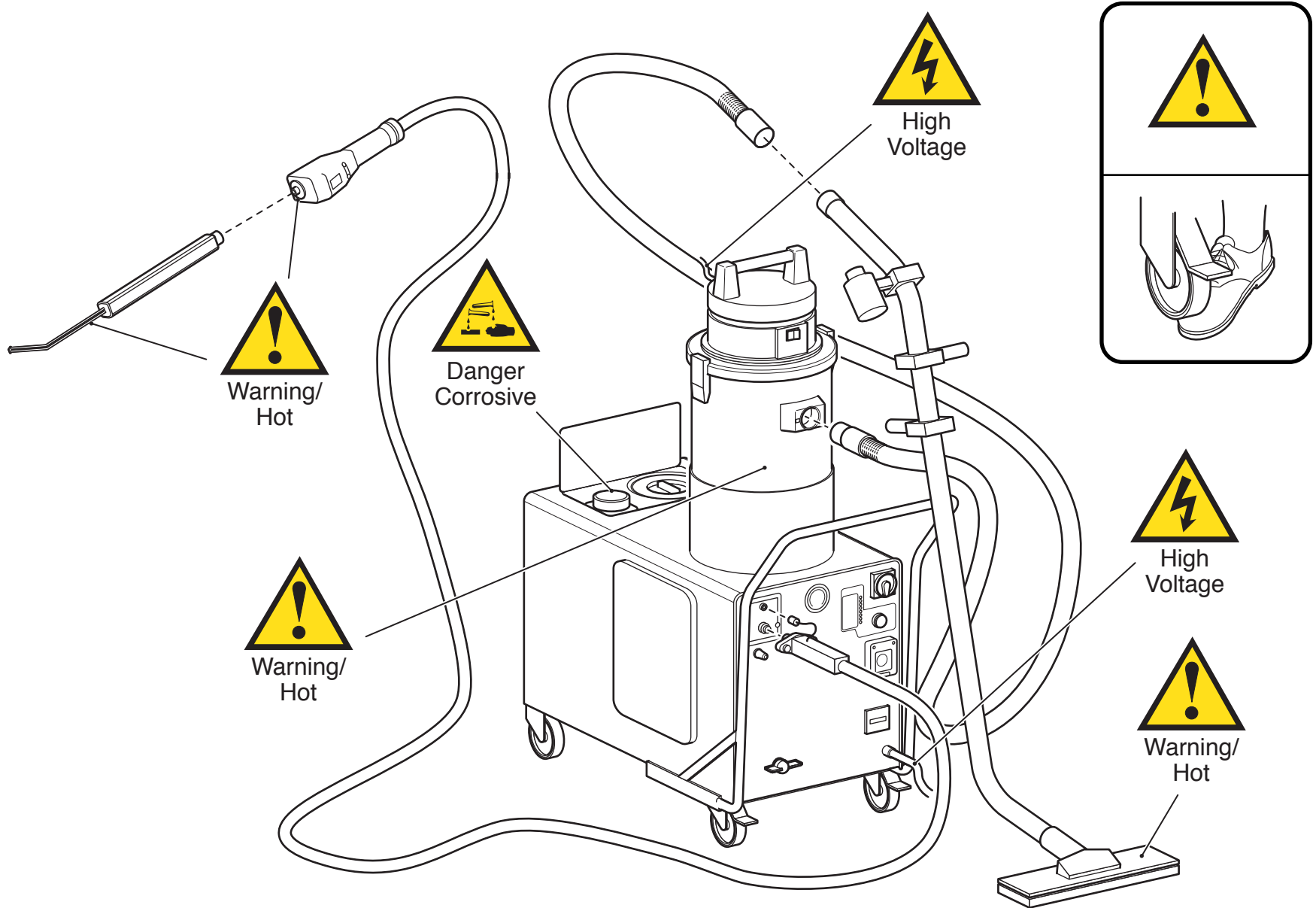

# REA - Saturno Junior and Super Models

## ADDITION OF WATER AND DETERGENT

**Key**

- Set/Move
- Remove/Replace
- Release/Secure



**Attention:** Do not put detergent or other contaminants in water tank. If this occurs do not turn unit on (or shut off immediately if unit is on) and refer to trouble shooting section.

1.

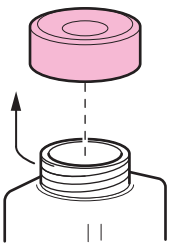

Carefully loosen and remove the lid.

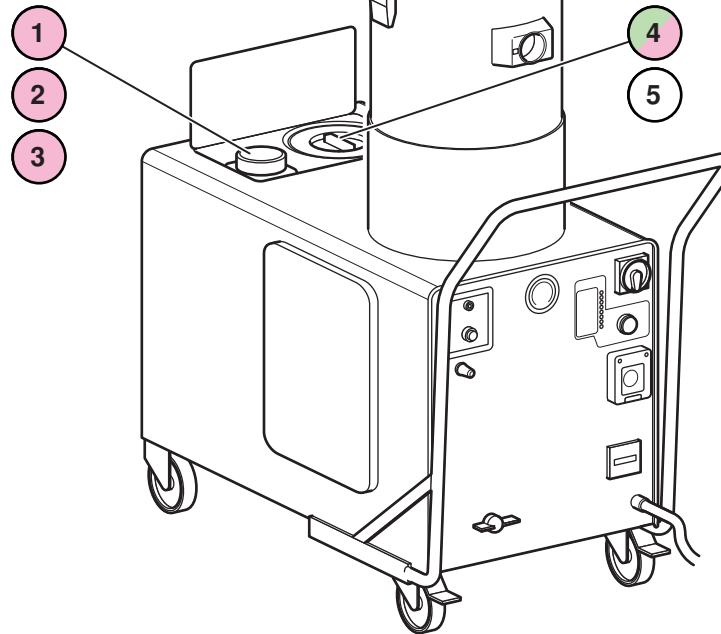

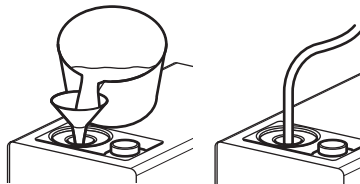

**Attention:** Do not use dirty pails, hoses or funnels to fill water tank. Do not use detergent funnel for filling of water tank.

5.

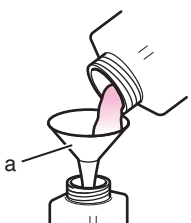

Add clean cold water from an approved source.

2.

Carefully fill detergent tank with detergent using a funnel (a).

**Attention!** Only use recommended products from REA. Do not use other substances without conferring with REA.

3.

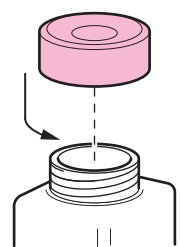

Carefully replace and secure the lid.

4.

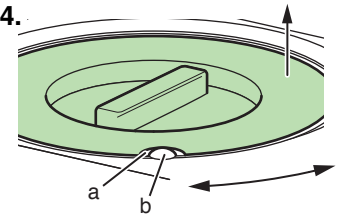

Rotate lid of water tank until the gap (a) aligns with one of the screws (b) and remove lid.

# REA - Saturno Junior and Super Models INITIAL CHECKS

**Key**

- Set/Move
- Remove/Replace
- Release/Secure

**1.**

Check that your water tank is full.

**2.**

Check that your detergent tank is full.

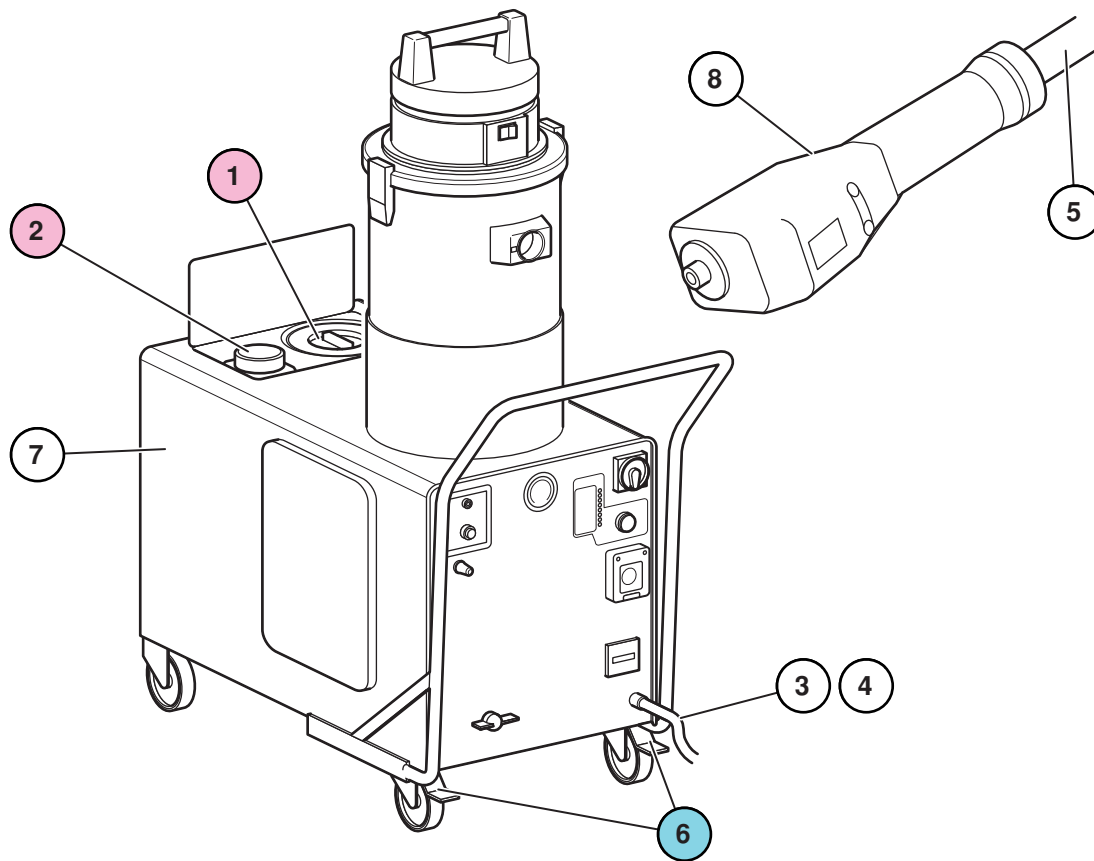

**8.**

Ensure the handle switch (a) is not depressed.

**7.**

Ensure machine is appropriately anchored.

**3.**

Ensure there is no risk of tripping over the electrical cord.

**4.**

Check condition of power cord and plug for damage.

**5.**

Ensure there are no kinks in the steam hose.

**6.**

Apply front brakes.

# REA - Saturno Junior and Super Models

## ASSEMBLY OF ACCESSORIES

**Key**

- Set/Move
- Remove/Replace
- Release/Secure

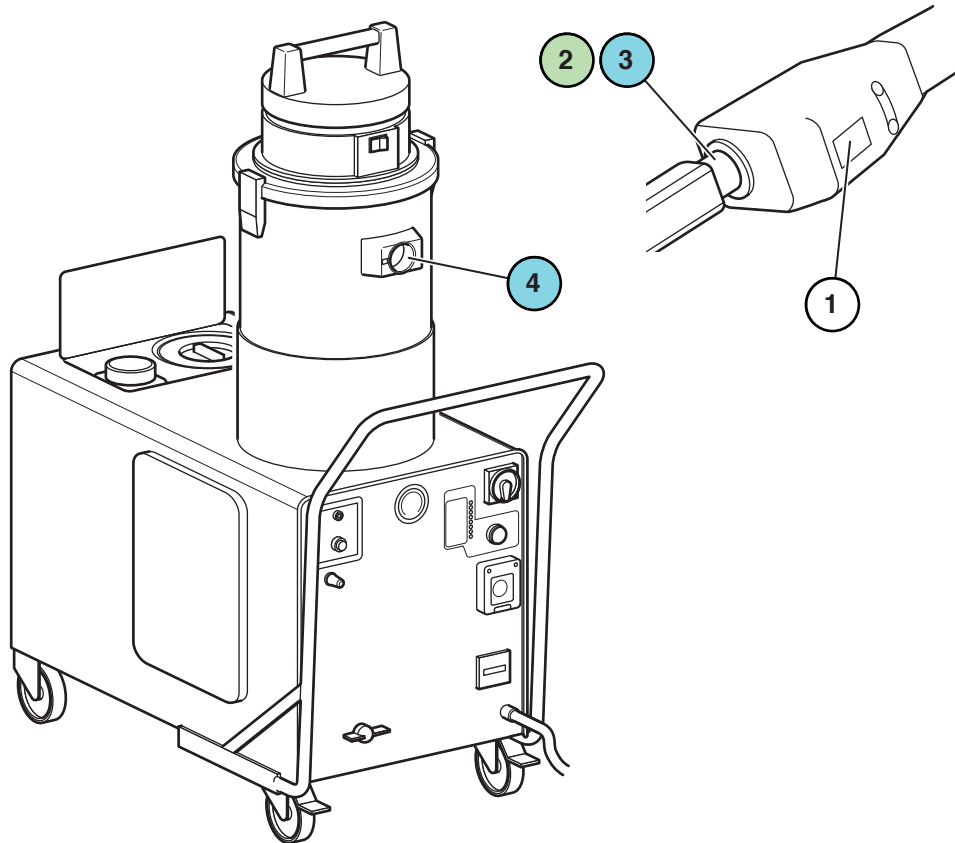

**Warning:**  
Steam will escape from loose accessory connections

**Warning:**  
Threaded end of handle can be hot

1.

NEVER assemble/disassemble attachments without digital readout (a) set to zero.

2.

Fit locator pin (a) on handle into hole on accessory to seat pieces.

3.

Firmly hand tighten connecting nut clockwise. If steam escapes from tightened connection please refer to trouble shooting section.

4.

Plug vacuum hose into socket on vacuum unit (if required).

**Note.**

Steam supply is regulated by the switch on the control Handle.  
0 = OFF.  
1 = Steam Only.  
2 = Steam Water and Detergent.  
3 = Steam and Water.  
4 = Steam Water Detergent & Vacuum.  
5 = Steam and Vacuum.  
6 = Vacuum Only.

# REA - Saturno Junior and Super Models START UP

**Key**

- Set/Move
- Remove/Replace
- Release/Secure

**1.**

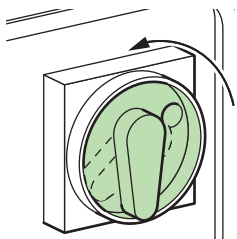

Ensure the main power switch is in the 'Off' position.

**2.**

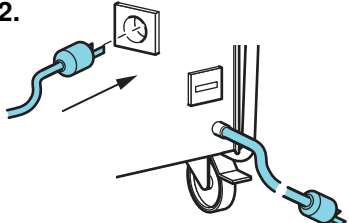

Plug main power cord into electrical outlet.

**3.**

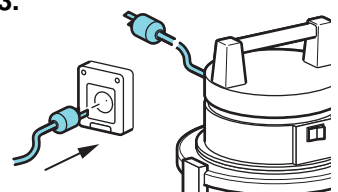

Plug vacuum power cord into electrical outlet on front panel of unit (if required).

**4.**

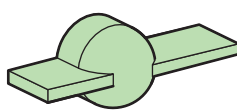

Check that the boiler exhaust valve is in the closed position.

**5.**

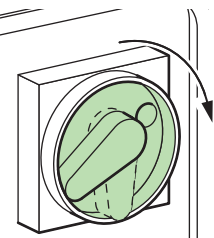

Turn 'On' the main power switch.

**6.**

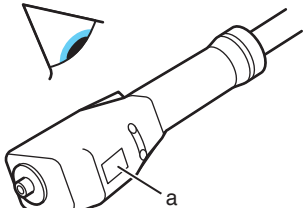

Ensure digital readout (a) on the handle is set to zero.

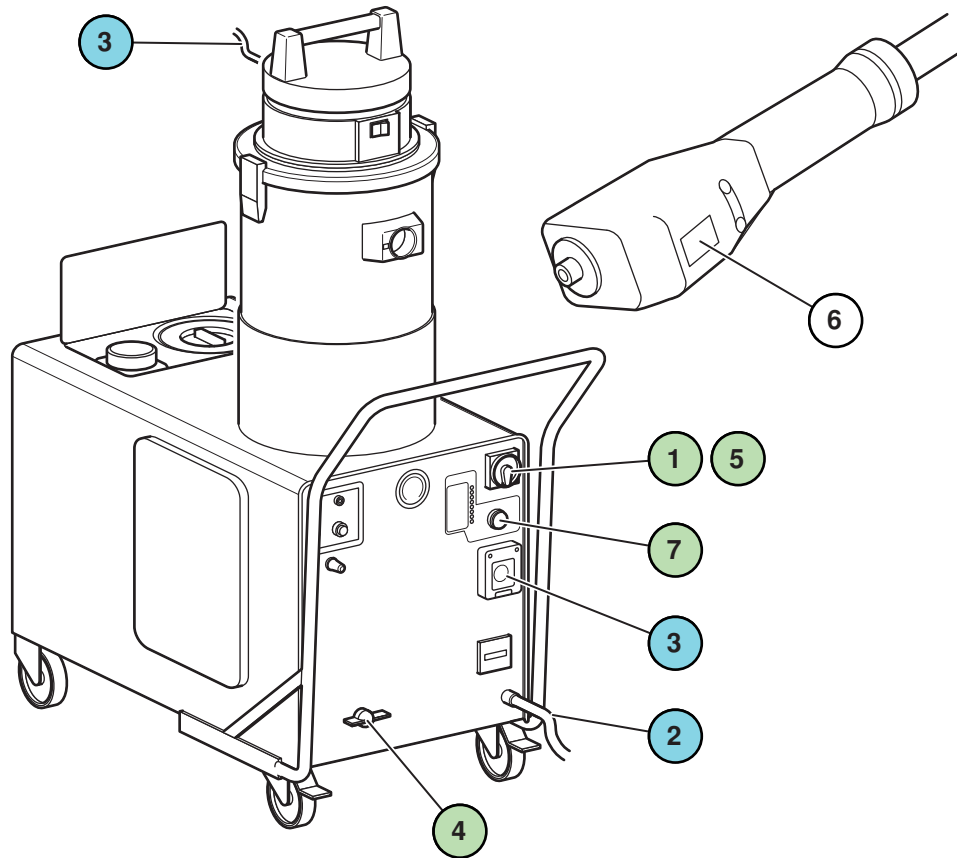

**Note.**

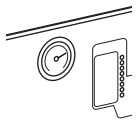

Pressure should never rise above 10 bar. If this occurs shut down immediately and refer to trouble shooting section.

**Note.**



Pump and resistance lights will illuminate during warm up. Once unit is ready for use the lights will go out. Indicator lights will turn on and off periodically during use - this is normal.

**7.**

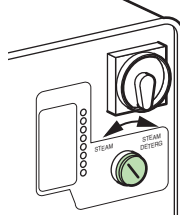

Select 'STEAM' (steam only) or 'STEAM DETERG' (steam, water and detergent).



# REA - Saturno Junior and Super Models SHUT DOWN

**Key**

- Set/Move
- Remove/Replace
- Release/Secure

**1.**

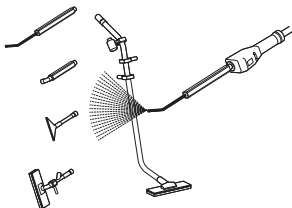

Clean accessories with steam and detergent prior to shut down.

**2.**

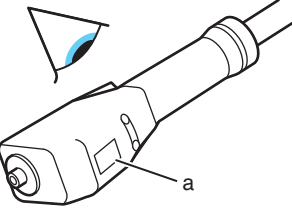

Return handle digital readout (a) to zero.

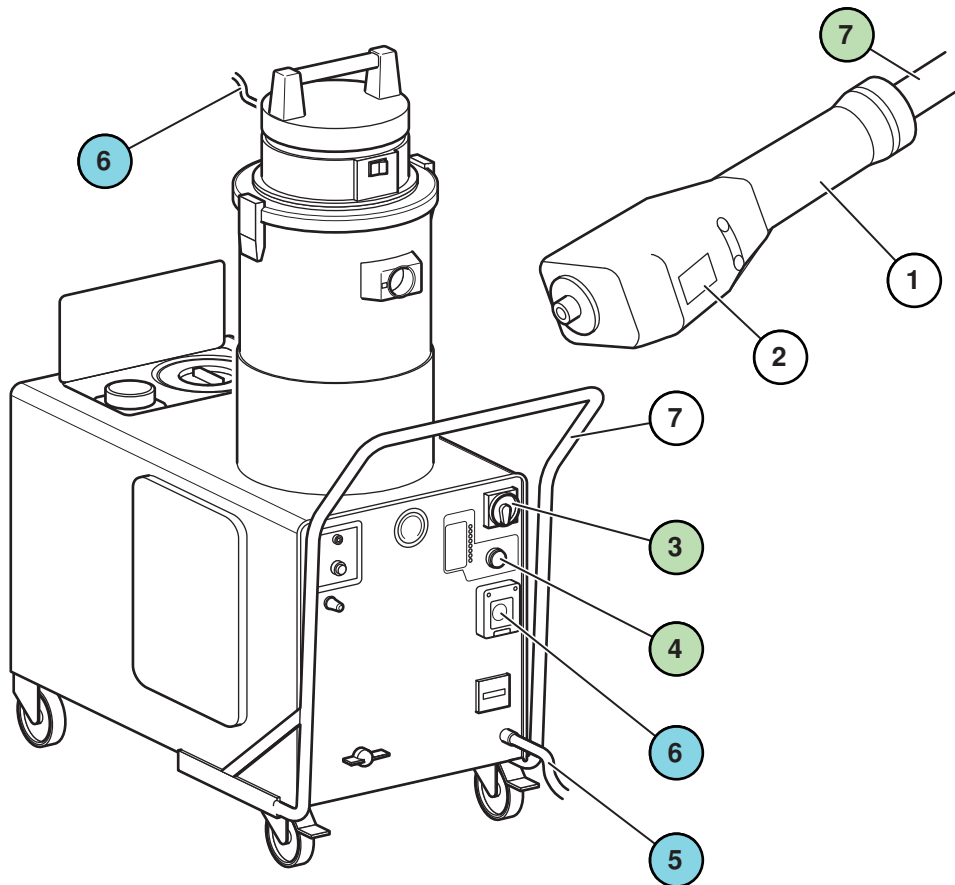

**7.**

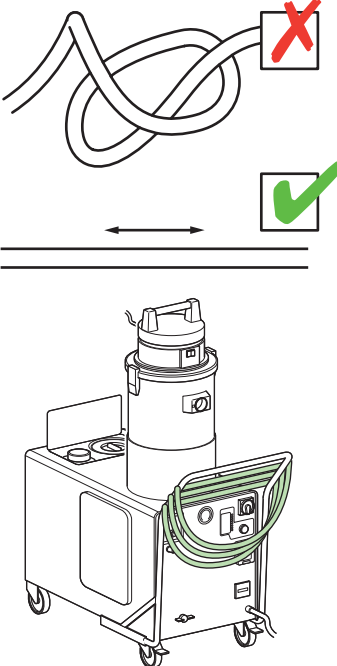

Extend steam hose fully to eliminate kinks. Wrap hose around the handle of unit.

**3.**

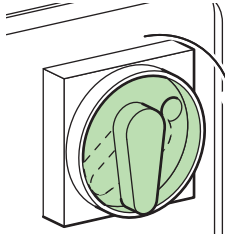

Turn 'Off' the main power switch.

**4.**

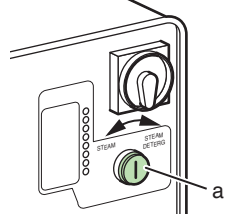

Turn steam setting (a) to middle position.

**5.**

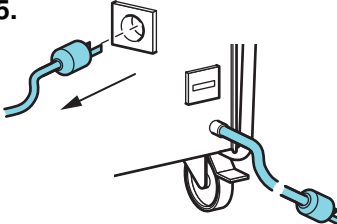

Disconnect main power cord from electrical outlet.

**6.**

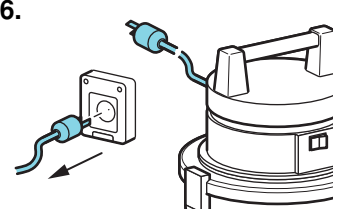

Disconnect vacuum power cord from electrical outlet on front panel of unit.

# REA - Saturno Junior and Super Models SHUT DOWN

**Key**

- Set/Move
- Remove/Replace
- Release/Secure

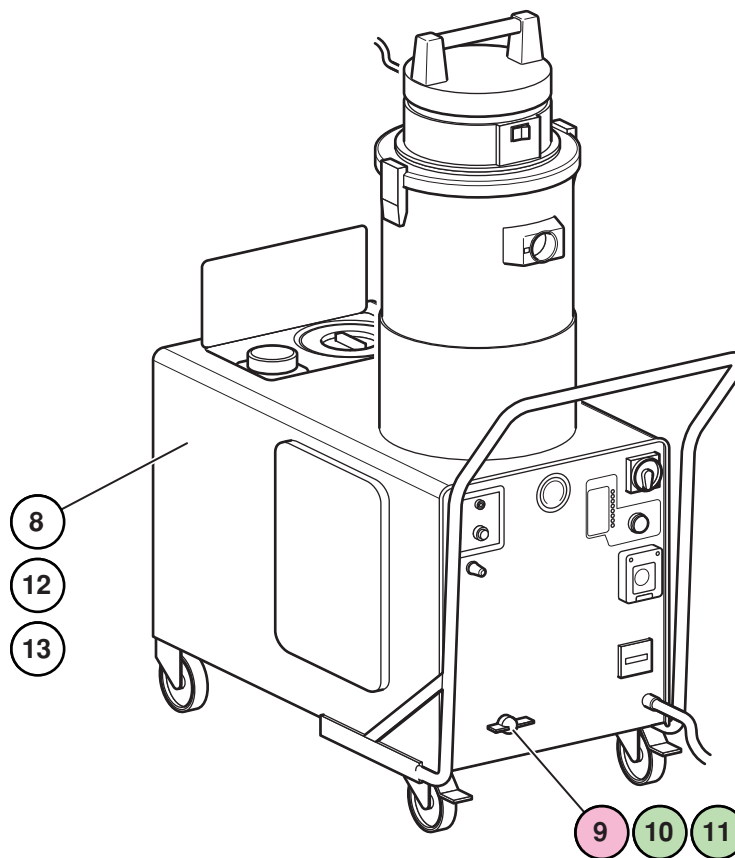

**8.**

Move unit to a appropriate area with drain to exhaust boiler.

**13.**

Cover machine when storing in a dusty environment.

**9.**

Place exhaust tool over the exhaust valve (a).

**10.**

Release the boiler exhaust valve quickly by turning 90° counter-clockwise. Steam will rapidly discharge from underneath the boiler. This is loud, notify others in area.

**11.**

Machine should stored with the boiler exhaust valve in the open position.

**12.**

Do not leave the machine in temperatures lower than 0°C.

# REA - Saturno Junior and Super Models

## FILTER CLEANING

**Key**

- Set/Move
- Remove/Replace
- Release/Secure

**1. Monthly**

Rotate lid of water tank until the gap (a) aligns with one of the screws (b) and remove lid.

**2.**

Release and remove screws (a) x3.

**3.**

Remove filter.

**4.**

Wash filter thoroughly under running water from an approved source.

**5.**

Replace filter.

**6.**

Replace and secure screws (a) x3.

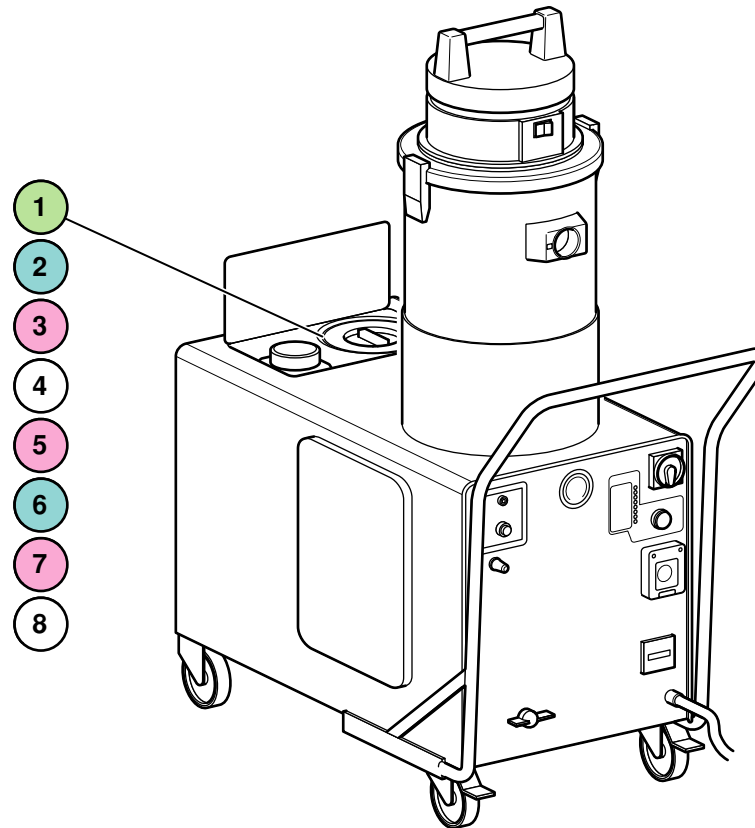

**8.**

Never leave the tank of water without the filter.

**7.**

Replace lid and secure.