



HDBU Series
Dynamic Braking Unit

HDBU Series

Dynamic Braking Unit

User manual



V1.0
User manual

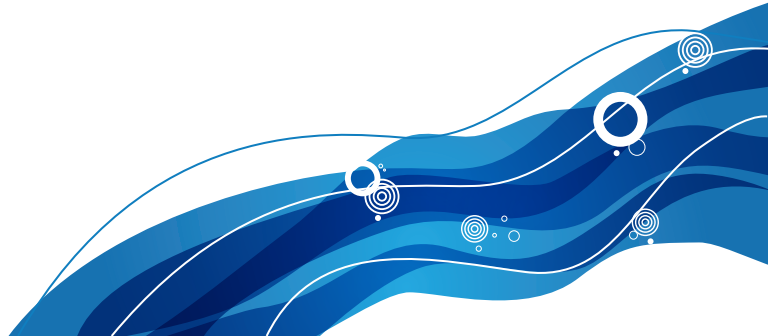

FOREWORD

Thank you for purchasing HDBU series dynamic braking unit manufactured by Shenzhen Hpmont Technology Co., Ltd!

HDBU series dynamic braking unit (hereinafter referred to as braking unit) are used with inverter to consume the feedback energy in the motor slowdown process and to achieve fast braking control.

This User Manual describes how to use the braking unit and its installation wiring, troubleshooting and daily maintenance etc. Before using the product, please read through this User Manual carefully. In addition, please do not use this product until you have fully understood safety precautions.

Note:

- Preserve this Manual for future.
- Due to product upgrade or specification change, and for the purpose of improving convenience and accuracy of this manual, this manual's contents may be modified.
- If you need the User Manual due to damage, loss or other reasons, please contact the regional distributor of our company or directly contact our company Technical Service Center.
- For the first time using, the user should carefully read this manual.
- If you still have some problems during use, please contact our company Technical Service Center.
- **Telephone: 4008-858-959 or 189 4871 3800**
- The product warranty is on the last page of this Manual, please preserve it for future.

CONTENTS

Chapter 1 Safety Information and Precautions	1
1.1 Safety Definition	1
1.2 Precautions	1
Chapter 2 Product Information.....	2
2.1 Part Name.....	2
2.2 Model Explanation.....	2
2.3 Nameplate	3
2.4 Fuse Explanation	4
Chapter 3 Mechanical Installation.....	1
3.1 Installation Precautions	1
3.2 Requirement for the Installation Site	1
3.3 Installation Direction and Space	2
3.4 Dimensions and Mounting Size	3
Chapter 4 Electrical Installation	4
4.1 Wiring Requirements	4
4.2 Power Terminal Description	5
4.3 Control Terminal Description.....	6
4.3.1 SK1 Terminal Description.....	6
4.3.2 SK2 Terminal Description.....	7
4.3.3 SW1 Dial Switch Description.....	8
4.3.4 Indicator Description	8
Chapter 5 Typical Application	9
5.1 Single Application.....	9
5.2 Two Braking Units for Parallel Application	10
5.3 Three Braking Units for Parallel Application	11
Chapter 6 Troubleshooting.....	12
Chapter 7 Maintenance.....	13
7.1 Daily Maintenance.....	13
7.2 Periodical Maintenance	14
7.3 Replacing Damaged Parts.....	14
7.4 Unwanted Braking Unit Disposal	14

Chapter 1 Safety Information and Precautions

1.1 Safety Definition



Danger: A Danger contains information which is critical for avoiding safety hazard.



Warning: A Warning contains information which is essential for avoiding a risk of damage to product or other equipments.



Note: A Note contains information which helps to ensure correct operation of the product.

1.2 Precautions

Before delivering, this product has been strictly checked and reliably packaged. Due to handling, loading and unloading in transit, it may cause damage. Therefore, after open the package please check product integrity carefully:

Check items	Check methods
Whether there is damage to parts or damaged	Check the overall appearance, check if there is damage in transit
If there is loose screws or other fasten parts	If necessary, use the screwdriver to check
Whether the manual intact	Check the manual

If has lacked, please contact manufacturer.

Chapter 2 Product Information

2.1 Part Name

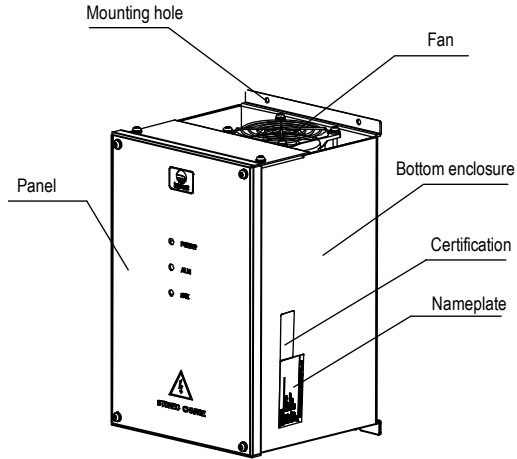

2.2 Model Explanation

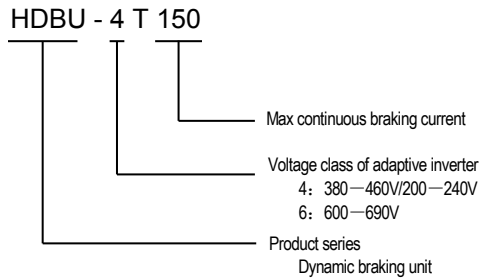

Table 2-1 Braking unit specifications

Model	DC input voltage (VDC)	Max continuous braking current (A)	Braking resistance range (Ω)	Voltage class of adaptive inverter (VAC)
HDBU-4T050	450—800	50	≥ 15	380—460
HDBU-4T075		75	≥ 10	
HDBU-4T100		100	≥ 7	
HDBU-4T150	250—800	150	≥ 5	380—460/200—240
HDBU-4T250		250	≥ 3	
HDBU-6T150	850—1200	150	≥ 8	500—690
HDBU-6T250		250	≥ 5	

Table 2-2 Selection for the braking unit

Inverter		Braking unit		
Voltage class	Power class	Model	Number	Configuration
380—460 VAC	11~22kW	HDBU-4T050	1	Single
380—460 VAC	30~37kW	HDBU-4T075	1	Single
380—460 VAC	45~55kW	HDBU-4T100	1	Single
380—460 VAC	75~110kW	HDBU-4T150	1	Single
380—460 VAC	132~200kW	HDBU-4T250	1	Single
380—460 VAC	220~315kW	HDBU-4T250	2	Parallel
380—460 VAC	355~400kW	HDBU-4T250	3	Parallel
600—690 VAC	75~110kW	HDBU-6T150	1	Single
600—690 VAC	132~220kW	HDBU-6T250	1	Single
600—690 VAC	250~400kW	HDBU-6T250	2	Parallel

2.3 Nameplate

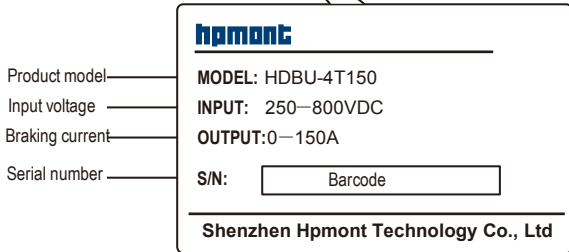
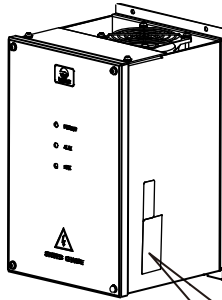

2.4 Fuse Explanation

The DC bus input side of braking unit is built-in fuse whose location is shown as Figure 2-1.

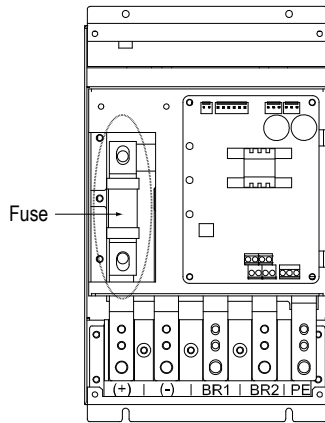

Figure 2-1 Location of fuse

If the braking unit is damaged by accident, this fuse can break off the electrical connection between braking unit and inverter's DC bus so as to avoid inverter damage.

When the fuse is damaged, please use another fuse which is the same as the damaged one, such as the same brand and model. If have any question, please contact us or our suppliers.

Chapter 3 Mechanical Installation

3.1 Installation Precautions



Danger

- Do not install if the braking unit is incomplete or impaired.
- Make sure that the braking unit is far from the explosive and combustible things.
- Only when the power supply is completely cut-off 10 minutes later can you do the wiring job.



Warning

- It is required not only carry the display panel and the cover but also the bottom enclosure of the braking unit.
- Do not play metal into the braking unit when installing.

3.2 Requirement for the Installation Site

Ensure the installation site meeting the following requirements:

- Do not install at the direct sunlight, moisture, water droplet location;
- Do not install at the combustible, explosive, corrosive gas and liquid location;
- Do not install at the oily dust, fiber and metal powder location;
- Be vertical installation on fire-retardant material with a strong support;
- Make sure adequate cooling space for the braking unit so as to keep the ambient temperature among - 10—+ 40℃;
- Install at where the vibration is less than 5.9m/s² (0.6g).

Note:

1. It needs derating use if the braking unit operation temperature exceeds 40℃. The derating value of braking unit shall be 2% for each degree centigrade. Max. allowed temperature is 50℃.
2. Keep ambient temperature among -10 – +40℃. It can improve the braking unit operation performance if install at the location with good ventilation or cooling devices (do not install the braking resistor mounted in proximity to the inlet of the braking unit).

3.3 Installation Direction and Space

When install several braking unit, it should consider the heat dissipation of air flow. To achieve good cooling efficiency, install the barking unit perpendicularly wall-mounted side by side and always provide the following space to allow normal heat dissipation. Just as shown in Figure 3-1.

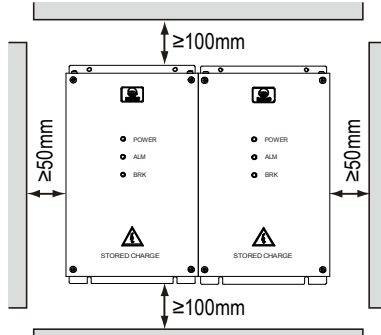

Figure 3-1 Installation of braking unit

When one braking unit is mounted on the top of the other, the distance between the top and the next should exceed 300mm. Just as shown in Figure 3-2.

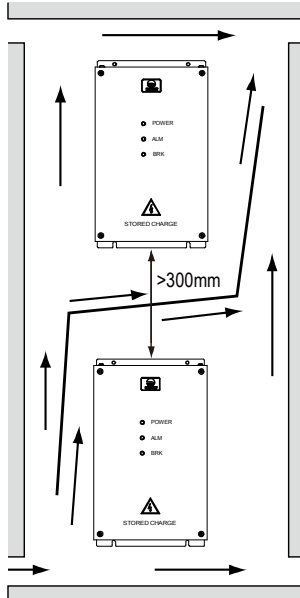

Figure 3-2 Installation of several braking units

3.4 Dimensions and Mounting Size

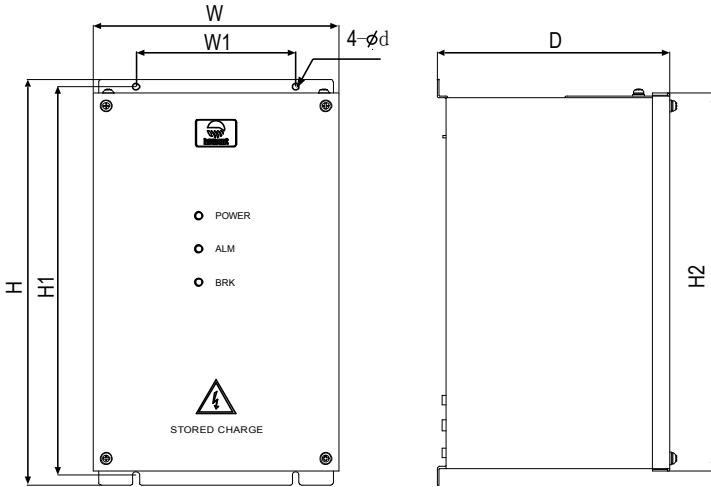

Figure 3-3 Braking unit dimensions

Table 3-1 Braking unit dimension descriptions

Model	Dimension (mm)			Mounting size (mm)				Gross weight (kg)
	W	H	D	W1	H1	H2	d	
HDBU-4T050	138	190	140	120	180	176	4.5	3
HDBU-4T075								
HDBU-4T100								
HDBU-4T150	185	305	180	120	292	284	5	8
HDBU-4T250								
HDBU-6T150								
HDBU-6T250								

Chapter 4 Electrical Installation



Danger

- Only qualified electrical engineer can perform wiring job.
- Bare metallic part of the power terminal wiring should be with insulating tape to wrap up.
- Only when the power supply is completely cut-off can you do the wiring job.
- You can't open the braking unit's cover to do wiring operation until the power is cut-off 10 minutes later. Do not wire or detach the braking unit's internal devices at power-on situation.
- Do not do wiring operation until the internal charge indicator of the braking unit is off and the voltage between (+) and (-) of the main circuit terminals is below 36V.
- The earth terminal PE of the braking unit must be reliable earthing. It must use two separate earth wire due to the leakage current from the braking unit to ground.
- Do not touch the wire terminals of the braking unit when it is live. The main circuit terminals is neither allowed connecting to the enclosure nor short-circuiting.



Warning

- Make sure the inverter's power supply voltage is the same as the braking unit's rated voltage.
- Do not do dielectric strength test on the inverter.
- Do wiring connection of the braking resistor or the braking unit according to the wiring figure. Do not connect the braking resistor to DC terminals (+) and (-) of the braking unit.
- Make sure that the terminals are fixed tightly.
- Do not play screws, washers and metal bars etc. metal into the braking unit when installing.
- Do not mount the braking unit at the water pipe where may have a water droplet splash.
- Do not supply the damage or parts of insufficiency of the braking unit with power.

4.1 Wiring Requirements

1. For the two power terminals' wiring between the inverter and the braking unit, it is suggested to use the red and the black of 600V voltage level cable, to prevent the DC bus terminal wiring error.
2. For the wiring between the braking unit and the braking resistor, please use the 600V voltage level of high temperature cable.
3. The two lines should be closed and used twisted pair when connect the inverter with the braking unit so as to reduce the current loop. It suggests that the length of wiring should be less than 5m and not exceed 10m.
4. The interval distance between the control terminal wiring and the power terminal wiring should be greater than 0.3m so as to reduce the interference to control terminal signal.

4.2 Power Terminal Description

HDBU-4T050, HDBU-4T075 and HDBU-4T100 of power terminal layout are shown as Figure 4-1. HDBU-4T150, HDBU-4T250, HDBU-6T150 and HDBU-6T250 of power terminal layout are shown as Figure 4-2.

The descriptions are shown as Table 4-1.

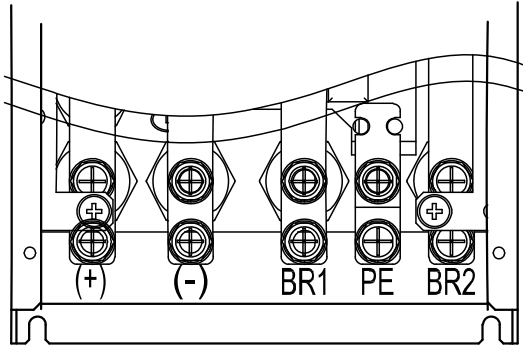

Figure 4-1 Power terminal layout 1 of braking unit

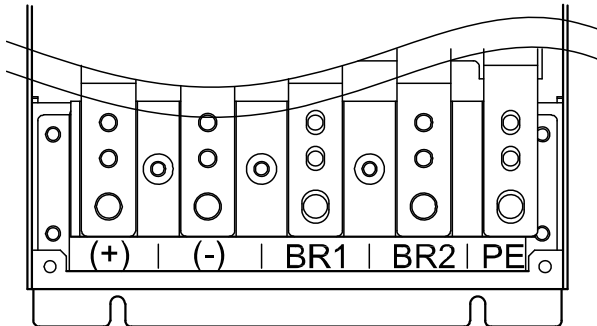

Figure 4-2 Power terminal layout 2 of braking unit

Table 4-1 Power terminal function description of braking unit

Terminal identification	Terminal name	Function description
(+), (-)	DC bus input terminal	Respectively connect to the inverter DC bus (+) and (-)
BR1、BR2	Terminal of connect to the braking resistor	Connect to the braking resistor
PE	Terminal of protective earth	Connect to the protective earth

4.3 Control Terminal Description

The control terminals, the dial switch and indicators are on the control board shown as Figure 4-3.

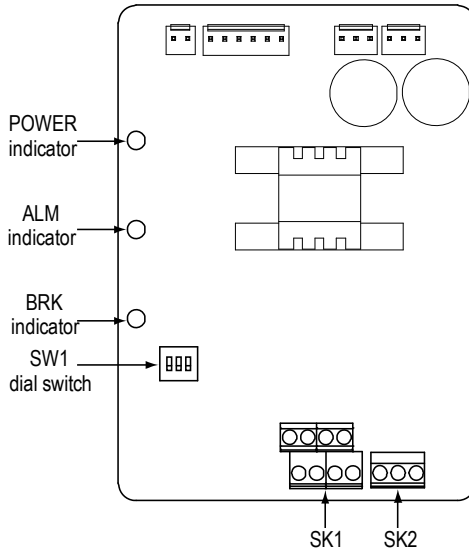

Figure 4-3 Position layout on the control board

4.3.1 SK1 Terminal Description

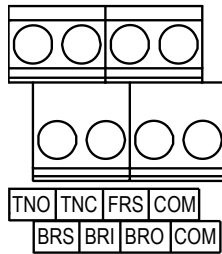

Figure 4-4 SK1 terminal layout

Table 4-2 SK1 terminal function description

Identification	Terminal name	Function description
TNO	Normally open terminal for braking resistor's overheated protection	Normally-open temperature switch for overheated protection input. This function is enabled when short connected with COM
TNC	Normally closed terminal for braking resistor's overheated protection	Normally-closed temperature switch for overheated protection input. This function is enabled when disconnected with COM Note: it need connect the TNO to the COM at the same time
FRS	Fault reset terminal	When the braking unit is faulty, connect the FRS to the COM to achieve fault reset function
BRS	Terminal for selective braking command source	When the BRS terminal is suspension, the braking unit's braking command is decided by the DC bus input voltage automatic detection value When the BRS and the COM are short connected, the braking unit's braking command is decided by the BRI terminal
BRI	Input terminal for braking command	When the BRI and the COM are short connected, the braking unit starts to operate
BRO	Output terminal for braking state	When the braking unit is at the braking state, this terminal output is enabled
COM	Signal ground	Signal reference ground

4.3.2 SK2 Terminal Description

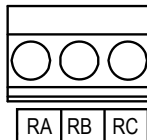

Figure 4-5 SK2 terminal layout

Table 4-3 SK2 terminal function description

Identification	Terminal name	Function description
RA/RB/RC	Fault output terminal	Relay of 1c contact output RC-RA: Normally open contact RC-RB: Normally closed contact Contact rating: 250VAC /3A or 30VDC /1A

4.3.3 SW1 Dial Switch Description

According to the different power supply voltage of adaptive inverter, it need set the braking unit's braking voltage threshold via the SW1 dial switch. To set the dial switch, it should be under the braking unit power-off condition. The relation between the braking voltage threshold and the dial switch is shown as Table 4-4.

Table 4-4 Set the voltage

Product model	Power supply voltage of adaptive inverter (VAC)	DC voltage for braking action (VDC)	SW1 switch setting
HDBU-4T050 HDBU-4T075 HDBU-4T100	380—460	690	
		750	
HDBU-4T150 HDBU-4T250	200—240	380	
	380—460	690	
		750	
HDBU-6T150 HDBU-6T250	600—690	1190	

4.3.4 Indicator Description

Table 4-5 Indicator description

Identification	Name	Function description
POWER	Braking unit power-on indicator	On: The braking unit is at power-on state Off: The braking unit is not at power-on state
ALM	Braking unit's fault alarm state indicator	On: The braking unit is faulty Off: The braking unit is not faulty
BRK	Braking unit's state indicator	On: The braking unit is at braking state Off: The braking unit is at standby state

Chapter 5 Typical Application

 Danger
<ul style="list-style-type: none"> Only when the braking terminal cover has been fitted can you switch on AC power source. Do not remove the cover after power is switched on.

 Warning
<ul style="list-style-type: none"> Do not check or detect the signal during the braking unit operation. Do not touch the energy-consumption braking resistor due to the high temperature.

5.1 Single Application

According to Figure 5-1, connect the inverter, braking unit and braking resistor when use one braking unit. And according to the inverter's voltage class in Table 4-4, set the braking voltage threshold of braking unit.

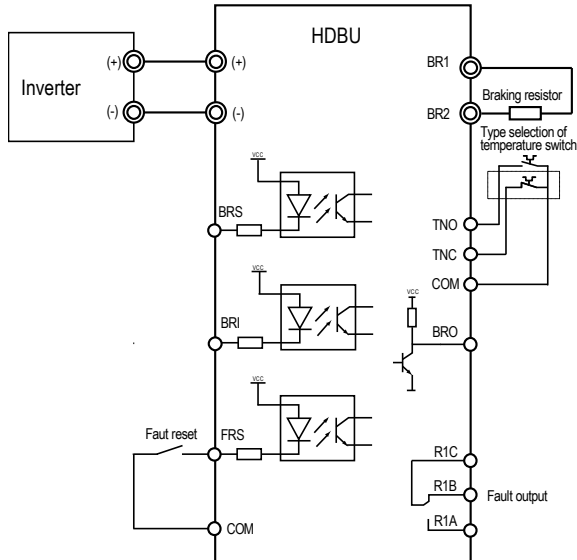

Figure 5-1 Single application connection

The braking resistor selection cannot exceed the braking unit output capacity range. Please refer to Table 2-1 for proper braking resistor.

Due to the braking resistor of large power consumption, it is suggested that over-temperature protective switch should be mounted to achieve overheated protection for the braking resistor.

5.2 Two Braking Units for Parallel Application

When the output capacity of one braking unit can not satisfy the application requirement, you can use two braking units in parallel to increase the braking output capacity.

Please according to Figure 5-2, connect two braking units for parallel application. Set one braking unit as master and set another braking unit as slave, then the slave one will auto-track the master one to brake synchronously.

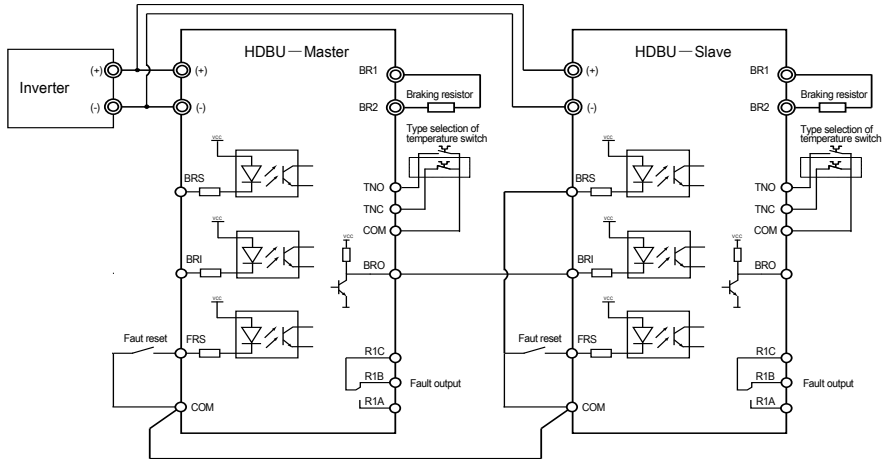

Figure 5-2 Two braking units for parallel application

In the above figure, connect the braking state output terminal (BRO) of the master braking unit with the braking command input terminal (BRI) of the slave one. And it need short connect the braking command source selective terminal (BRS) of the slave braking unit with the signal ground (COM), and signal grounds of the master and the slave should be connected at the same time.

5.3 Three Braking Units for Parallel Application

According to Figure 5-3, connect the three braking units for parallel application. Set one braking unit as the master and the other two as the slaves, and then the two slaves will auto-track the master one to brake synchronously.

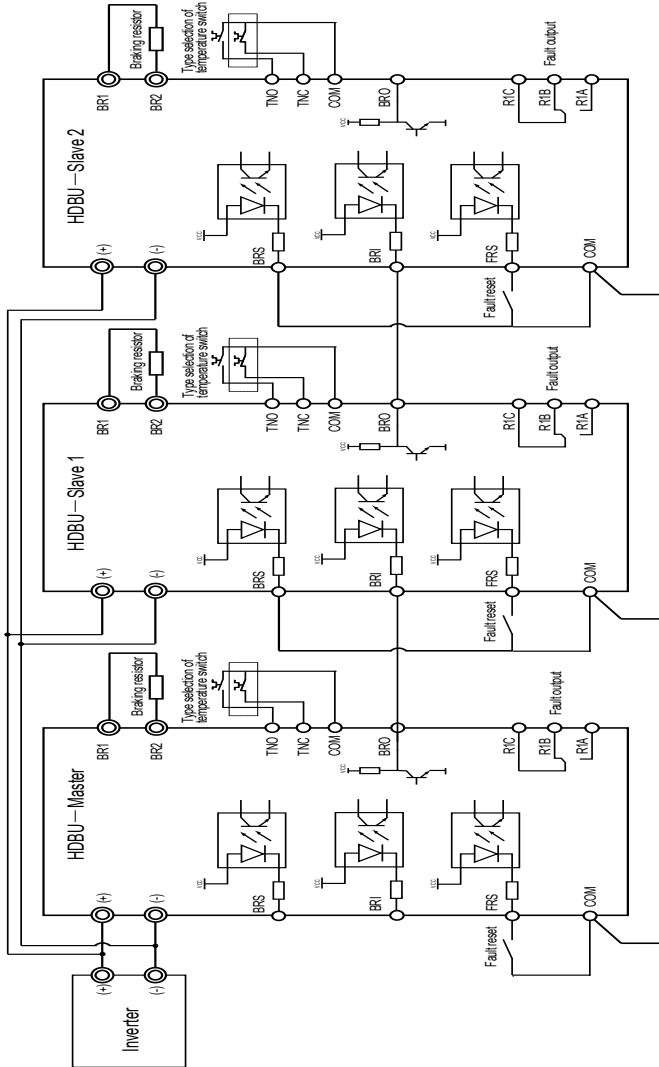

Figure 5-3 Three braking unit for parallel application

Chapter 6 Troubleshooting

When fault alarm occurs, please take proper action according to the Table 6-1.

Table 6-1 Fault alarm description and counter-measures

Fault name	Possible reasons of fault	Counter-measures
Overvoltage at inverter braking	<ul style="list-style-type: none"> • The braking resistor value is too big • The inverter preset deceleration time is too short 	<ul style="list-style-type: none"> • Decrease the braking resistor value • Properly increase the deceleration time
Braking unit fault	<ul style="list-style-type: none"> • The heatsink temperature is too high • The power module of braking unit is faulty 	<ul style="list-style-type: none"> • Please check the fan or change the work environment of braking unit • Please contact the manufacture
Braking unit does not operate all the time, and no fault is displayed	<ul style="list-style-type: none"> • The internal fuse has been fused • The external locked signal is enabled • The inverter's deceleration time is too long, which does not meet the braking working conditions 	<ul style="list-style-type: none"> • Change the fuse • Please relieve the external locked signal • Please decrease the inverter's deceleration time
Braking resistor overheated protection	<ul style="list-style-type: none"> • The braking resistor power is too small • The heat dissipation condition of braking resistor is too bad • The braking unit internal over-temperature protection circuit is faulty 	<ul style="list-style-type: none"> • Please select larger power braking resistor • Improve the braking resistor working environment • Please contact the manufacture

Chapter 7 Maintenance



Danger

- Only a trained and qualified professional person can maintain the braking unit.
- Maintenance personnel should take off all metal jewellery before carrying out maintenance or internal measurements in braking unit. Suitable clothes and tools must be used.
- High voltage still exists at the internal when the braking unit is powered up or running.
- Checking and maintaining can only be done after braking unit's AC power is cut off. And wait for at least 10 minutes if maintain the cover.



Warning

- For the braking unit stored for more than 2 years, please use voltage regulator to increase the input voltage gradually.
- Do not leave metal parts like screws or pads inside the braking unit.
- Do not make modification on the inside of braking unit without instruction from the supplier.
- There are IC components inside the braking unit, which are sensitive to static electricity. Directly touch the components on the PCB board is forbidden.

7.1 Daily Maintenance

Some unexpected accidents may occur during operation. Therefore you should maintain the braking unit conditions according to the Table 7-1, record the operation data, and investigate problems immediately.

Table 7-1 Daily checking items

Items	Content	Criteria
Operating environment	Temperature and humidity	-10—+40℃, derating at 40—50℃
	Dust and water dripping	No water dripping
	Gas	No strange smell
Braking unit	Oscillation and heating	Stable oscillation and proper temperature
	Noise	No abnormal sound

7.2 Periodical Maintenance

Customer should check the braking unit in short time or every 3 to 6 months according to the actual environment so as to avoid hidden problems and make sure the braking unit runs well for a long time.

General Inspection:

- Check whether the screws of control terminals are loose. If so, tighten them with a screw driver;
- Check whether the main circuit terminals are properly connected; whether the mains cables are over heated;
- Check whether the power cables and control cables are damaged, especially check for any wear on the cable tube;
- Check whether the insulating tapes around the cable lugs are stripped, and for signs of overheating near terminations.

Note:

1. Dielectric strength test of braking unit has already been conducted in the factory. Do not do the test again. Otherwise, the braking unit might be damaged.
 2. If insulation test to braking unit is necessary, it must be done to the ground after all input/output terminals are short-connected by conductors. It is forbidden for each terminal to ground test. It is recommended to use the 500V megger.
 3. For braking unit stored for a long time, it must be powered up every 2 years. When supplying AC power to braking unit, use a voltage regulator to gradually raise the input voltage to rated input voltage at least 5 hours.
-

7.3 Replacing Damaged Parts

The easily damaged component is the cooling fan. The lifetime depends largely on the application environment and preservation. The user can decide the time when the components should be replaced according to their service time.

Generally, due to the wear of bearing and aging of the fan vanes, the life of fan is 60,000 hours.

Criteria: After the braking unit is switched off, check if the abnormal conditions such as crack existing on fan vanes and other parts. When the braking unit is switched on, check if braking unit running is normal, and check if there is any abnormal oscillation.

7.4 Unwanted Braking Unit Disposal

When disposing the braking unit, please pay attention to the following factors:

The capacitors may explode if they are burnt.

Poisonous gas may be generated when the plastic parts like front covers are burnt.

Disposing method: Please dispose unwanted braking unit as industrial waste.



Shenzhen Hpmont Technology Co., Ltd

Warranty Agreement

1. The warranty period of the product is 18 months (refer to the barcode on the product body). During the warranty period, if the product fails or it is damaged under condition of normal use by following the user's manual, our company will be responsible for free maintenance.
2. The starting time of the warranty period is manufacturing date (see the barcode on the product body), but we could negotiate settlement under special condition.
3. Within warranty period, maintenance will be charged for damages caused by the following reasons:
 - A. The damage is caused by improper use or repair/modification without prior permission;
 - B. The damage is caused by abnormal voltage, fire, flood, other disasters and second disasters;
 - C. The damage is caused by dropped or transportation after purchase;
 - D. The damage is caused by the operation not following this user's manual;
 - E. The damage or failure is caused by the trouble out of the equipment (e.g. external device).
4. If there is any failure or damage to the product, please correctly fill out the Product Warranty Card in detail.
5. The maintenance fees are charged according to the newly adjusted Maintenance Price List by our company.
6. In general, the warranty card will not be reissued. Please keep the card and present it to the maintenance personnel when asking for maintenance.
7. If there is any problem during the service, please contact the agent of our company or our company directly.
8. This agreement should be interpreted by Shenzhen Hpmont Technology Co., Ltd.

Shenzhen Hpmont Technology Co., Ltd

Address: 3F, Building 28, Wangjingkeng Industry Park, Xili Dakan, Nanshan District, Shenzhen, China

Telephone: 4008-858-959 or 189 4871 3800

P.C.: 518055

Http://www.hpmont.com

E-mail: marketing@hpmont.com