



Allen-Bradley

*Bulletin 2707
MicroView
Operator
Interface
Module*

(Cat. No. 2707-MVH232)

User Manual

Important User Information

Because of the variety of uses for the products described in this publication, those responsible for the application and use of this control equipment must satisfy themselves that all necessary steps have been taken to assure that each application and use meets all performance and safety requirements, including any applicable laws, regulations, codes and standards.

The illustrations, charts, sample programs and layout examples shown in this guide are intended solely for purposes of example. Since there are many variables and requirements associated with any particular installation, Allen-Bradley does not assume responsibility or liability (to include intellectual property liability) for actual use based upon the examples shown in this publication.

Allen-Bradley publication SGI-1.1, *Safety Guidelines for the Application, Installation, and Maintenance of Solid-State Control* (available from your local Allen-Bradley office), describes some important differences between solid-state equipment and electromechanical devices that should be taken into consideration when applying products such as those described in this publication.

Reproduction of the contents of this copyrighted publication, in whole or in part, without written permission of Allen-Bradley Company, Inc., is prohibited.

Throughout this manual we use notes to make you aware of safety considerations:



ATTENTION: Identifies information about practices or circumstances that can lead to personal injury or death, property damage or economic loss.

Attention statements help you to:

- identify a hazard
- avoid the hazard
- recognize the consequences

Important: Identifies information that is critical for successful application and understanding of the product.

Using this Manual

Chapter 1

Objectives	1-1
Contents	1-1
Intended Audience	1-2
Conventions	1-2
Related Publications	1-2

MicroView Overview

Chapter 2

Objectives	2-1
General Information	2-1
Description	2-2
Display	2-2
Keypad	2-2
Communications Port	2-3
Power Connector	2-3
Keypad	2-3
Function Key Operations	2-4
MODE Key Operations	2-5
Communications Port	2-5
RS-232 Communications	2-6
Programming the MicroView	2-6
MicroView Programming Software (MDPS)	2-6
Upload/Download Connections	2-7
Default Settings	2-7
Operating Parameters	2-7
Operating System	2-8
Product Options	2-8
Product Accessories	2-8

Initial Setup and Mode Menu

Chapter 3

Objectives	3-1
Apply Power	3-1
Powerup Sequence	3-2
Powerup Sequence	3-2
Mode Menu	3-4
Resetting the MicroView	3-5
To reset the MicroView:	3-5
Setting Communication Parameters Manually	3-5
Special Functions for Controller Operations	3-6
P-A/D	3-6
Mode	3-6
Prgm	3-6
Clr Flt	3-6

Master Security Code	3-7
To Enter a New Master Security Code:	3-7
Enabling / Disabling Scaling	3-8
To Enable or Disable Scaling:	3-9
Using the Simulate Mode	3-9
To Simulate an Application:	3-9
Test Functions	3-11

Transferring Applications

Chapter 4

Objectives	4-1
Upload / Download Connections	4-1
Computer Setup	4-2
Downloading an Application	4-2
Uploading an Application	4-7

Running Applications

Chapter 5

Chapter Objectives	5-1
Application Documentation	5-1
Bit Write Mode	5-1
Screen Types	5-2
Screen Navigation	5-2
Screen Links	5-2
Advisor Option	5-2
Function Keys	5-3
Auto Return	5-3
Continue	5-3
Menu and Sub-Menu Screens	5-4
Main Menu	5-4
Sub-Menus	5-4
Security Screens	5-4
Data Display Screens	5-5
Data Entry Screens	5-5
Recipe Screens	5-6

Installation

Chapter 6

Objectives	6-1
Safety Guidelines	6-1
Operating Environment	6-1
Enclosures	6-1
Connecting DC Power	6-2

**Communication
 Connections and Setup**

Chapter 7

Chapter Objectives	7-1
Wiring Guidelines	7-1
Connecting RS-232 Devices	7-2
To connect the MicroView to the MicroLogix controller:	7-2
Communicating with a Logic Controller	7-3
Communications Parameters	7-3

**Troubleshooting and
 Maintenance**

Chapter 8

Chapter Objectives	8-1
Troubleshooting Recommendations	8-1
Equipment Required	8-1
Common Operating Problems	8-2
Error Messages	8-2
Communication Error Codes	8-3
Using the Test Functions	8-4
To access the test functions:	8-4
Display Test	8-5
To perform the display test:	8-5
Core ROM Test	8-5
To perform the Core ROM test:	8-5
System RAM Test	8-6
To perform the System RAM Test:	8-6
System ROM Test	8-7
To perform the System ROM Test:	8-7
Program ROM Test	8-8
To perform the Program ROM Test:	8-8
Keyboard Test	8-8
To perform the keyboard test:	8-8
Communications Port Test	8-10
To test the communications port:	8-10
Watchdog Test	8-11
To perform the Watchdog Test:	8-11
Cleaning the Display Window	8-12
Removing Paint and Grease	8-12

Specifications

Appendix A

MicroView Specifications A-1

MicroView Cable Diagrams

Appendix B

MicroView Cables B-1
Catalog No. 2707-NC9 B-2
Catalog No. 1761-CBL-HM02, 2707-NC11 B-3

**MicroView Special
Controller Functions**

Appendix C

Objectives C-1
Accessing Special Functions C-1
Accessing Special Functions C-2
Using the P-A/D Function C-2
 MicroLogix File Types C-2
Reading Controller Input and Output Files C-3
Reading / Writing Controller Status Files C-4
Reading / Writing Controller Binary and Integer Files C-5
Reading / Writing Controller Timer Files C-6
Reading / Writing Controller Counter Files C-8
Reading / Writing Controller Control Files C-10
Using the Mode Function C-12
Using the Program Function C-13
Using the Clear Fault Function C-14
 To clear controller faults: C-14

Using this Manual

Objectives

Read this chapter to familiarize yourself with the rest of the manual. You will learn about:

- Contents of this manual
- Intended audience
- Conventions
- Related publications

Contents

The following table lists the contents of each chapter:

Chapter	Title	Purpose
1	Using this Manual	Provides an overview of the manual.
2	Overview of MicroView	Contains a description of the MicroView and accessory devices.
3	Initial Setup and Main Menu	Describes initial desktop setup of the MicroView using main menu functions.
4	Transferring Application Files	Describes how to upload and download application files between the MicroView and a personal computer.
5	Running Applications	Describes the basic screen types. Also describes the different function key operations.
6	Installation	Provides procedures for mounting the MicroView. Also provided are wiring instructions and recommendations.
7	Communication Connections and Setup	Describes RS-232 connections. Setup guidelines are provided for MicroLogix controllers.
8	Troubleshooting and Maintenance	Provides assistance in identifying and correcting common operating problems. Cleaning recommendations are also provided.
Appendix A	Specifications	
Appendix B	Cable Diagrams	
Appendix C	MicroView Special Controller Functions	
Index		

Intended Audience

No special knowledge is required to operate the MicroView. If you are wiring the MicroView, you must be familiar with the electrical codes in your area (see inside front cover).

You should be familiar with the MicroView Programming Software (see related publications below).

Conventions

This manual uses the following conventions:

- Keys that you press on the MicroView are enclosed in brackets [].
For example: [NEXT] refers to the NEXT key on the MicroView.
- References to menus are initial cap followed by the word Menu.
For example: Special Menu, Main Menu, Other Menu
- All MicroView displays are shown inside a rectangular box.

1 Reset	3 Spec
2 Comm	4 Other

Related Publications

The following publications may be helpful for additional reference.

MicroView Publications

Publication / Catalog Number	Title
2707-805 May 95 or Later	MicroView Programming Software, Programming Manual
2707-801 April 95 or Later	DTAM Programming Software, Programming Manual

Other Publications

Publication / Catalog Number	Title
1761-6.1 August 1994 or Later	MicroLogix User Manual

MicroView Overview

Objectives

This chapter describes the MicroView and accessories. It contains these sections:

Section	Page
General Information	2-1
Description	2-2
Keypad	2-3
Communications Port	2-5
RS-232 Communications	2-6
Programming the MicroView	2-6
Default Settings	2-7
Accessories	2-8

General Information

The MicroView interfaces with the MicroLogix controller. The MicroView allows operators to monitor and manipulate process data on the plant floor.

RS-232 Port. The MicroView has an RS-232 communications port. The RS-232 port allows point-to-point connections with a MicroLogix controller. The RS-232 port also allows the MicroView to be connected to an IBM™ compatible personal computer.

Memory Capability. Storage of the operating system, configuration information, and user-programmed screens are maintained in nonvolatile memory providing storage for approximately 50 screens.

Recipe Operations. Recipe type functions allow operators to quickly modify blocks of data. Download data to a maximum of 10 non-sequential register addresses per screen. Link multiple recipe screens to download data to more than 10 addresses.

Flexible Function Key Operations. Two function keys provide a convenient way to trigger screen displays and change display screens.

Point-Access/Display Function. Allows you to monitor or modify data files in MicroLogix controllers. Use this function to set up and debug application programs.

Description

The front panel of the MicroView terminal is shown below.

Figure 2.1
MicroView (front view)

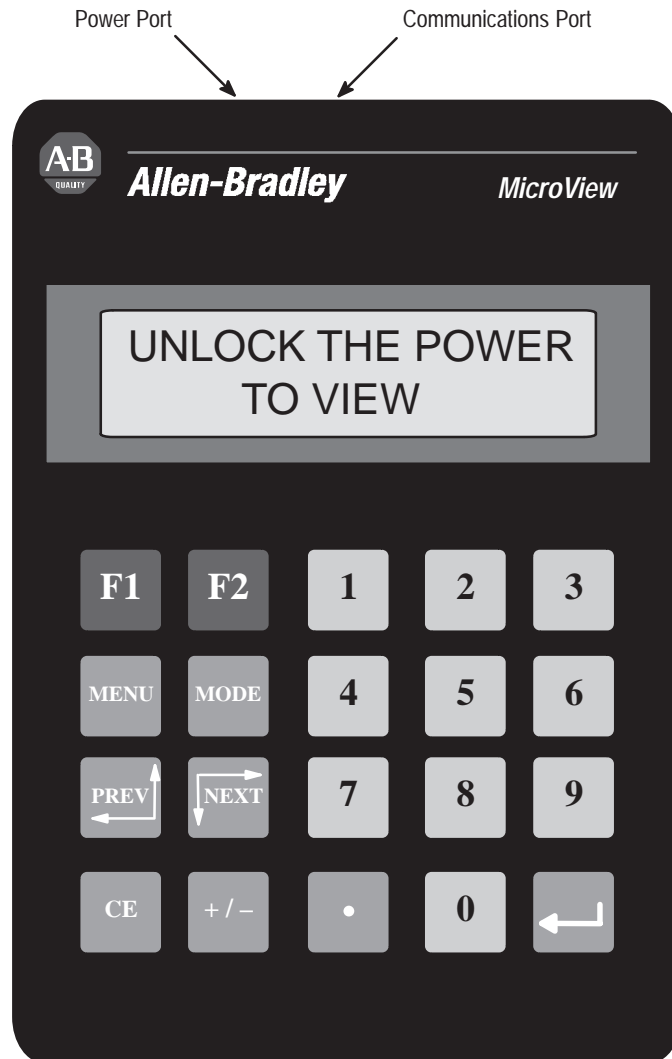

Display

The 2 line by 16 character display uses high contrast LCD technology with LED backlighting.

Keypad

The keypad is separated by color into easily identified groups or functions. In addition, each key has a raised dome in the center to provide tactile feedback.

Figure 2.2
MicroView (Top view)

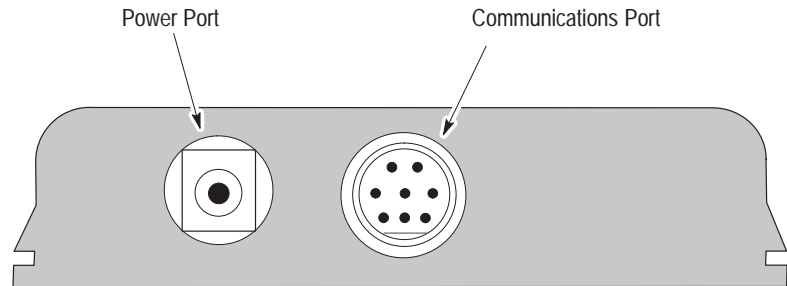

Communications Port

The MicroView operator interface has a communications port located on the top edge. The communications port is an 8 pin mini DIN connector configured with an RS-232 channel and a 24 VDC power supply connection.

Power Connector

The power connector is a 2 conductor power jack used to connect an external power source to the MicroView. This power source is required when the MicroView is connected to a PC for program transfers.

Keypad



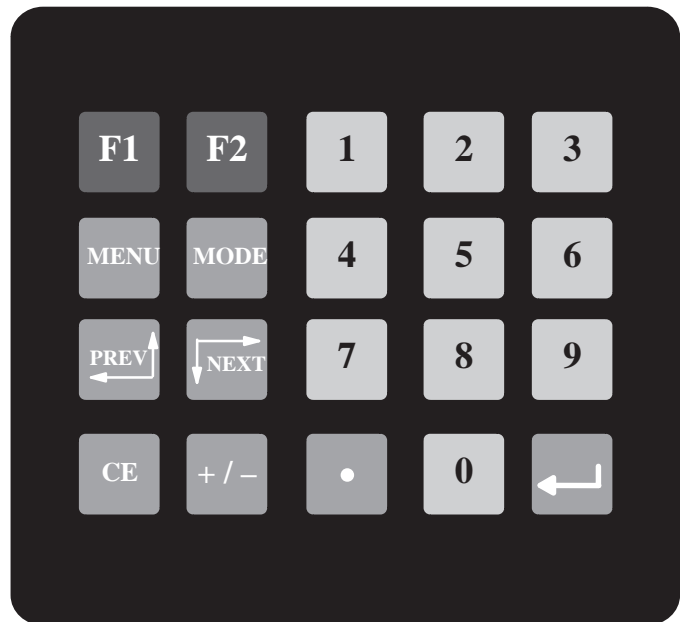





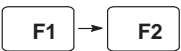

Figure 2.3
Keypad



The MicroView uses a sealed membrane, tactile feedback keypad. The keys are color coded to easily identify key functions.

Key Color	Function
Blue	Function Keys, F1 and F2
Dark Grey	Display/Format Control
Light Grey	Numeric Entry

The following table defines the function of each keypad key.

Key	Function
	Returns to the main menu of an application.
	Accesses special features and configuration of MicroView operating parameters.
	Steps back through a sequence of linked screens.
	Steps forward through a sequence of linked screens.
	Clears an entire value during data entry.
	Toggles a data entry value between positive or negative.
	Enters a decimal point.
	Sends data to the controller. Data can either be default values or data entered at the keyboard.
	Enters numbers 0 to 9 during data entry or selects a numbered item shown on the display.
	Displays any application screen assigned to the key. These keys can also set or clear bits at two consecutive registers in the controller data table.

Function Key Operations →

Function keys can be linked to application screens allowing quick access to critical data display or data entry screens. For example, if the F1 function key is linked to Recipe Screen 10, the operator can press F1 at any point in the application to download recipe registers on screen 10 to the processor.

A control mode can be assigned to each function key linked to a screen.

Control Mode	Function
Auto Return	Returns to the screen displayed before the function key was pressed.
Continue	Continues to the next screen in the link regardless of the screen displayed before the function key was pressed.
Bit Write Mode	Allows the function key when pressed to set or clear a bit in the controller. Bit Write Mode operates with either Auto Return or Continue mode. The function keys access 2 contiguous word data elements defined by the user. For example, assign function keys F1 to F2 to N7:20 and N7:21.

MODE Key Operations MODE

The MODE key accesses a menu of options allowing you to set features and operating parameters of the MicroView.

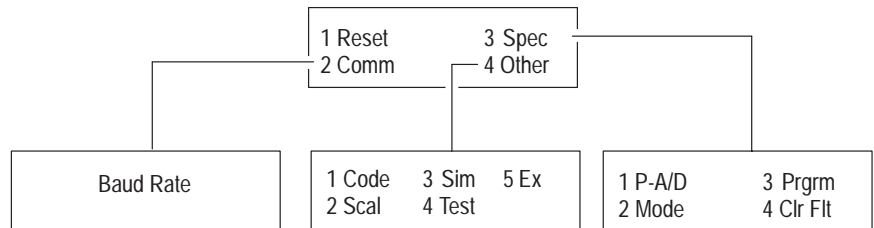

Mode Menu	Select this option:	To perform this function:
1 Reset		Resets the Unit
2 Comm	1 Baud Rate	Specifies 300, 1200, 2400, 9600, 19200 bits per second
3 Special	1 P-A/D	Displays and/or modifies data files in the processor.
	2 Mode	Places processor in RUN mode or PROGRAM mode.
	3 Prgrm (Program)	Transfers application files between the MicroView and PC.
	4 Clr Flt (Clear Fault)	Clears all processor faults in the MicroLogix controller.
4 Other	1 Code	Modifies the master security code of the MicroView.
	2 Scal (Scale)	Converts controller values to engineering units.
	3 Sim (Simulate)	Verifies an application without controller connected.
	4 Test	Tests memory, communications, keyboard and display.
	5 Ex (Exit)	Returns to the Mode menu.

Communications Port

All communications are through an 8 pin mini DIN connector on the top of the MicroView. The connector is an RS-232 port.

Figure 2.4
MicroView Communications Port

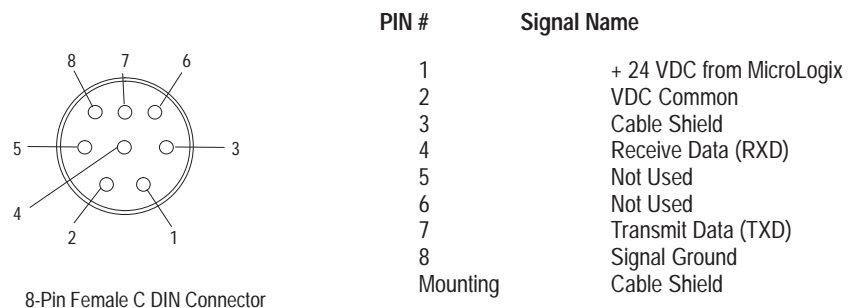

RS-232 Communications

The RS-232 port allows point-to-point communications with MicroLogix controllers.

Figure 2.5
RS-232 Communications

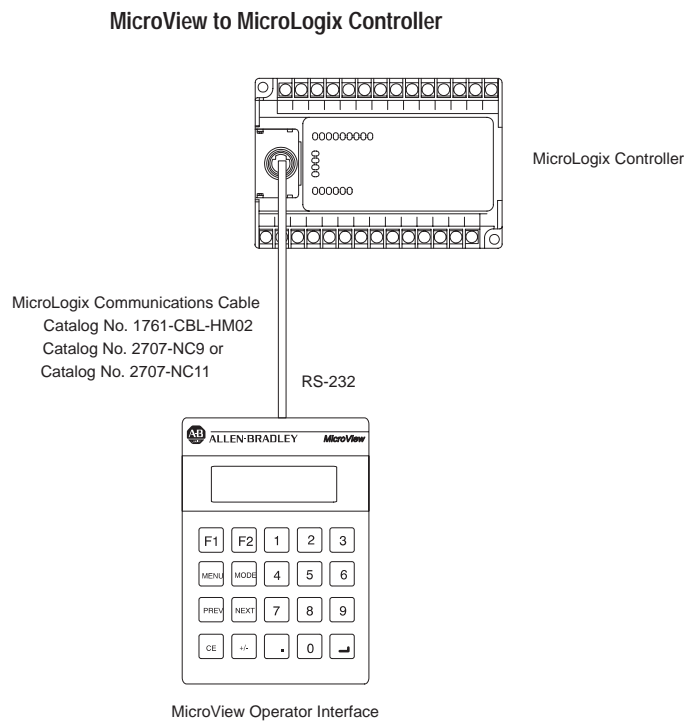

Programming the MicroView

The MicroView is programmed off-line using a personal computer running MicroView Programming Software (MDPS). Operating system upgrades can also be transferred using an IBM™ compatible personal computer.

MicroView Programming Software (MDPS)

You can use MicroView Programming Software (Catalog No. 2707-NP2, Version 1.00 or later) or DPS software (Catalog No. 2707-NP, Version 5.00 or later) to create application screens for the MicroView Operator Terminal. For a description of MicroView Programming Software (MDPS), refer to the Programming Manual (Publication No. 2707-805).

Upload/Download Connections

For programming and configuration, the MicroView is connected to your computer's RS-232 port, using a programming cable (Catalog No. 2707-NC8). See Appendix B if you need to construct your own cable.

Figure 2.6
Upload/Download Connections

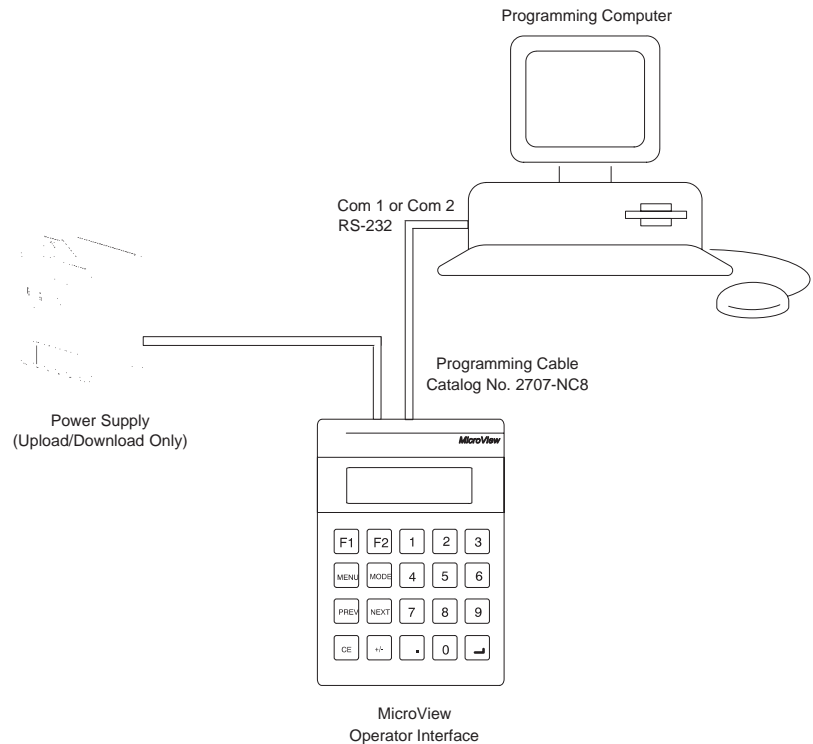

Default Settings

The MicroView is preset at the factory with the following defaults:

Operating Parameters

The default operating functions are shown in the table below. The operating functions can be set using the MicroView Mode Menu. Refer to Chapter 3.

Function	Parameter	Default Value
Com-Port	Baud	9600
	Data Bits	8 (Fixed)
	Parity	None (Fixed)
Other	Simulate	Off
	Master Code	00000000 (All zeros)
	Scale	On

Operating System

The MicroView is provided with a default application file using MicroLogix DF1 operating system.:

The application file displays a screen with the message:

**No Application
Program Loaded**

Product Options

The table below lists the options available for the MicroView.

Item	Catalog No.	Description
MicroView	2707-MVH232	Hand-Held MicroView with RS-232 Communications Port
MicroView	2707-MVP232	Panel-Mount MicroView with RS-232 Communications Port
Programming Software	2707-NP (Version 5.00 or later)	Use to create application screens for the MicroView on a personal computer. Software allows completed applications to be transferred between the MicroView and a personal computer. Will also support application development for DTAM Plus and DTAM Micro operator interfaces.
	2707-NP2 Version 1.00 or later	Use to create application screens for the MicroView on a personal computer. Software allows completed applications to be transferred between a personal computer and the MicroView.

Product Accessories

The following accessories are available for the MicroView.

Item	Catalog No.	Description
MicroView Face Plate Mounting Kit	2707-MVMNT	Allows the 2707-MVH232 hand-held MicroView to be surface-mounted to a panel. The MicroView unit slides into panel adapter housing. An integral cable assembly connects the MicroView 8 pin DIN connector to an 8 pin DIN connector on the panel adapter.
MicroView Programming Cable	2707-NC8	RS-232 cable connects MicroView and a personal computer. Use to upload or download applications with a personal computer running DPS or MDPS software.
MicroLogix Communications Cable	1761-CBL-HM02 2707-NC11	RS-232 cable connects MicroView to MicroLogix controller for run-time operations. (Length: 2 meters)
MicroLogix Communications Cable	2707-NC9	RS-232 cable connects MicroView to MicroLogix controller for run-time operations. (Length: 15 meters)
120V AC to DC Adapter	2707-PS120	Provides DC voltage output for the MicroView. Operates on 120 VAC input line voltage.
220V AC to DC Adapter	2707-PS220	Provides DC voltage output for the MicroView. Operates on 220 VAC input line voltage.

Initial Setup and Mode Menu

Objectives

This chapter describes how to apply power to and then configure the MicroView using the menu keys. Instructions on how to use the Simulate mode to run an application are also provided. This chapter contains the following sections:

Section	Page
Apply Power	3-1
Powerup Sequence	3-2
Mode Menu	3-4
Resetting the MicroView	3-5
Setting Communication Parameters Manually	3-5
Special Functions for Controller Operations	3-6
Entering a New Master Security Code	3-7
Enabling or Disabling Scaling	3-8
Using the Simulate Mode	3-9
Test Functions	3-11

Apply Power

This section describes power connections for initial desktop setup and programming. Refer to Chapter 6 for installation wiring instructions.

The MicroView operates on 24 VDC power supplied either through the power port or the communications port. For run-time operations with the MicroLogix controller, the MicroView is supplied with 24 VDC through the cable from the MicroLogix controller connected to the communications port.

For application download/upload operations, the MicroView is supplied with 24 VDC through the power port using a separate power adapter. You can use the AC to DC Adapters: Catalog No. 2707-PS120 for 120 VAC or Catalog No. 2707-PS220 for 220 VAC power.



ATTENTION: Verify that the power is disconnected from the power source before wiring. Failure to disconnect power may result in electrical shock.

If you use an AC/DC power adapter, make sure that the supply voltage to the MicroView is 11 to 25 volts DC and of the correct polarity. Incorrect voltage may damage the MicroView.

1. Connect the AC to DC Adapter to the MicroView's power port.

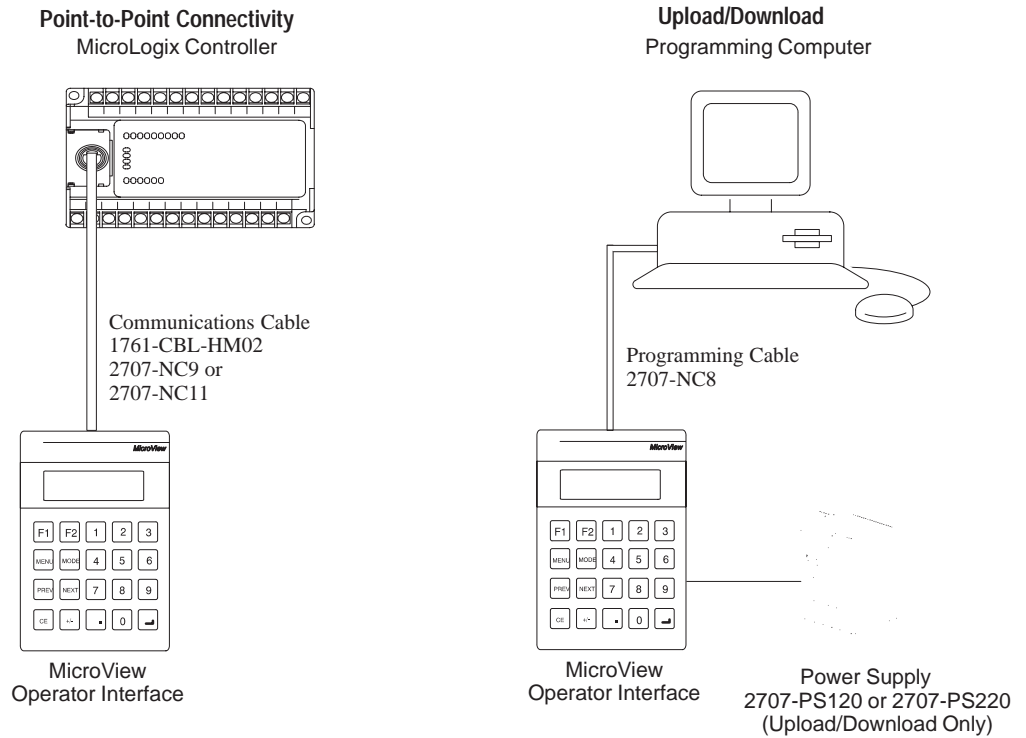

2. Apply power to the MicroView by plugging the AC to DC Adapter into the proper power source (check adapter label to verify voltage).
The MicroView performs a powerup sequence.

Powerup Sequence

The powerup sequence is automatic, you do not have to respond to the screens. During the Power Up or Reset sequence, the MicroView performs a series of initialization and diagnostic tests.

Powerup Sequence

1. When power is first applied, the display will light and remain blank for approximately one second.
2. Then the display is tested, every pixel of the display is turned on for one second. If all of the pixels do not turn on, the display may be defective.

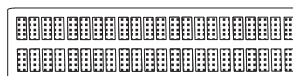

3. The display is again cleared and the MicroView verifies the system memory checksum, program checksum and system RAM.
4. If all tests pass, the MicroView will flash the boot code power-up screen for one second.

MicroView
Core: 1.01 (c) 1995

5. The following operating system screens are displayed. The first two flash briefly. The third screen is displayed until the MicroView is connected to the controller or the user presses a valid key.

MicroView
FRN: 1.01 (c) 1995

MicroView
MicroLogix DF1

MicroView DF1
Attempting Link

Mode Menu

Access the Mode Menu by pressing the [MODE] key. All other functions are halted when the menu is displayed.

The Mode Menu provides access to four functions:

1 Reset	3 Spec
2 Comm	4 Other

Select a menu item by pressing the corresponding numeric key [1] → [4]. The menu structure is shown below:

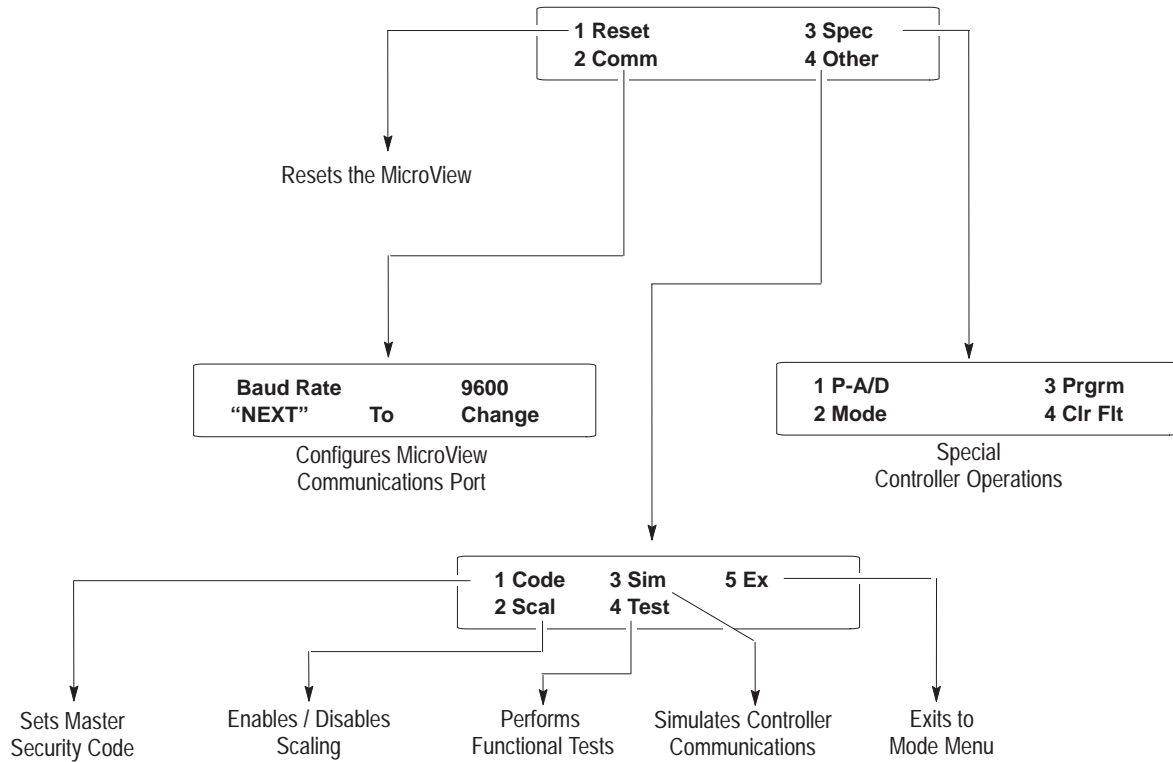

Resetting the MicroView

Use the reset function to reset the MicroView after configuration changes using the Mode Menu.

To reset the MicroView:

1. From the Mode Menu select [1] Reset.

1 Reset	3 Spec
2 Comm	4 Other

You are prompted:

1 = Reset
0 = Abort

2. Press [1] on the keypad to initiate the reset.

The MicroView resets. This has the same effect as turning the power off and on. The MicroView performs the self diagnostic tests and powerup displays as described in the Powerup Sequence.

Setting Communication Parameters Manually

The communication function on the Mode Menu lets you to manually set the baud rate of the communication port. Normally this parameter is set automatically from the programming software when an application is downloaded.

Select [2] Comm from the Mode Menu.

1 Reset	3 Spec
2 Comm	4 Other

This menu displays:

Baud Rate	9600
"Next" to	Change

Press [Prev] or [Next] to select a new rate: 300, 1200, 2400, 9600 or 19200.

Press [←] to save the new Baud rate setting. The screen will display:

COPYING TO MEM
Please Wait

After the new parameter is saved, the MicroView will again display the Mode Menu screen.

1 Reset	3 Spec
2 Comm	4 Other

Special Functions for Controller Operations

The Special Menu item provides access to special features for the controller operations.

Select [3] Spec from the Mode Menu.

1 Reset	3 Spec
2 Comm	4 Other

This menu displays:

1 P-A/D	3 Prgrm
2 Mode	4 Clr Flt

Note: Below are brief descriptions of each menu item. Refer to Appendix C for instructions on using the Special Menu items.

P-A/D

Use the Point Access / Display function to display and modify controller data files. The P-A/D function does not allow you to write to controller Input and Output files. Appendix C provides a listing of the applicable file types for MicroLogix controllers along with step-by-step instructions.

Mode

Select Mode to place the controller in either the run or program modes. This may be useful if you need to halt the controller for memory transfers.

Prgrm

Use the Program transfer function to initiate a transfer of data between a MicroView and a MicroLogix controller. The Program Mode uploads and downloads application programs between the MicroView and a personal computer.

Clr Flt

Use the Clear Fault function to clear all major and minor faults in the controller.

Master Security Code

The master security code provides access to all screen security codes and allows them to be modified. The master security code is initially set by the application program written using the MDPS or DPS software. See Catalog No. 2707-805 or 2707-801 (April 1995 or later) for more information.

Two master security codes perform special functions:

00000000 allows the operator to modify the existing master code without entering the current code.

99999999 does not allow operator to modify security codes. Changing of the master security code is only permitted through DPS software.

To Enter a New Master Security Code:

1. From the Mode Menu, select [4] Other.

1 Reset	3 Spec
2 Comm	4 Other

The Other Menu appears:

1 Code	3 Sim	5 Ex
2 Scal	4 Test	

2. Press [1] Code to select the Master security code function.

The master code entry screen displays:

Enter Master Code: _

3. Enter the current code and press [←].

You are prompted to enter the new code.

Enter New Master Code: _

4. Enter a new code and press [←]. The code must be 8 digits in length. If you enter less than 8 digits the entry is padded with zeroes. For example, an entry of 1234 is entered as 12340000.

The screen will display:

COPYING TO MEM Please Wait

After the new parameter is saved, the MicroView will again display:

1 Code	3 Sim	5 Ex
2 Scal	4 Test	

Note: Security codes can contain the wildcard character ? Any entered value will be treated as a match to the wildcard. You must make sure that the master security code is different from security codes using wildcard entries. Otherwise the master security code may be seen as a security code. For example, if the:

Security Code = 12??????
Master Code = 12368794

When the master security code above is entered, the MicroView interprets it as a security code.

Enabling / Disabling Scaling

Use scaling to convert data from a controller to engineering units such as gallons or psi. When scaling is disabled, the values are not converted. Refer to the MicroView Programming Software Manual for a description of how values are scaled. The scaling factor is determined by the application designer, it cannot be changed by the operator.

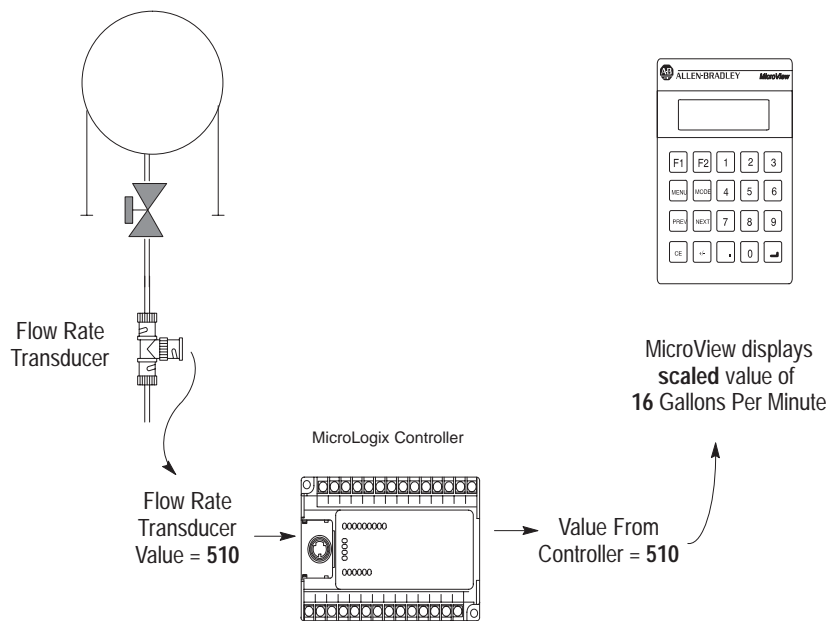

To Enable or Disable Scaling:

1. From the Mode Menu, select item [4] Other.

1 Reset	3 Spec
2 Comm	4 Other

The Other Menu appears:

1 Master	3 Sim	5 Ex
2 Scal	4 Test	

2. Select item [2] Scal.

The scale enable screen displays:

Scale	OFF (0)	← Current Setting
0=Off	1=On	

3. Press [1] on the keypad to enable scaling and [0] to disable scaling.

The screen will display:

COPYING TO MEM	
Please Wait	

After the new parameter is saved, the MicroView will again display:

1 Code	3 Sim	5 Ex
2 Scal	4 Test	

4. Select item [5] Ex to exit to the Mode Menu.

Using the Simulate Mode

The Simulate mode checks an application without having a controller connected. All data that normally would be sent by the controller, such as data for a display, is set to "0." Any ASCII data is set to "?". Selecting the Simulate function from the Mode Menu will:

- Halt communication between the MicroView and the controller.
- Simulate communication with a controller.

Disabling the Simulate mode resumes normal operation.

To Simulate an Application:

1. Download the application from the DPS software.
2. From the Mode Menu, select item [4] Other.

1 Reset	3 Spec
2 Comm	4 Other

The Other Menu appears:

1 Code	3 Sim	5 Ex
2 Scal	4 Test	

3. Select item [3] Sim.

The simulate enable screen displays:

Simulate	OFF (0)	← Current Setting
0=Off	1=On	

4. Press [1] to enable the Simulate mode.

The screen will display:

COPYING TO MEM	
Please	Wait

After the new parameter is saved, the MicroView will again display:

1 Code	3 Sim	5 Ex
2 Scal	4 Test	

5. Press [5] Ex to exit the Other Menu and display the Mode Menu.

1 Reset	3 Spec
2 Comm	4 Other

6. From the Mode Menu, reset the MicroView.

The MicroView displays a series of diagnostic tests, enters run mode, loads the application and then displays the Mode Menu of the application.

7. Run the program as you normally would. Notice that all display registers show data as a set of zeroes.

Pressure = 0000 PSI

← Data Display

8. After verifying the operation of the program, press the [MODE] key. All other functions are halted and the Mode Menu is displayed.
9. Disable the Simulate mode.

Test Functions

Selecting Test from the Other Menu displays the test screen:



Use the Test menu to perform the following:

- Display
- Core ROM
- System RAM
- System ROM
- Program ROM
- Keyboard
- Comm Port
- Watchdog
- Reset

Refer to Chapter 8, Troubleshooting and Maintenance for instructions on how to perform these tests.

Transferring Applications

Objectives

This chapter describes how to transfer applications between the offline programming software (DPS) operating on a personal computer and the MicroView. It contains the following sections:

Section	Page
Upload/Download Connections	4-1
Computer Setup	4-2
Downloading an Application	4-2
Uploading an Application	4-7

Upload / Download Connections

To upload or download an application to the MicroView, you must:

- connect a power supply (refer to Chapter 3).
- connect the (Catalog No. 2707-NC8) programming cable.

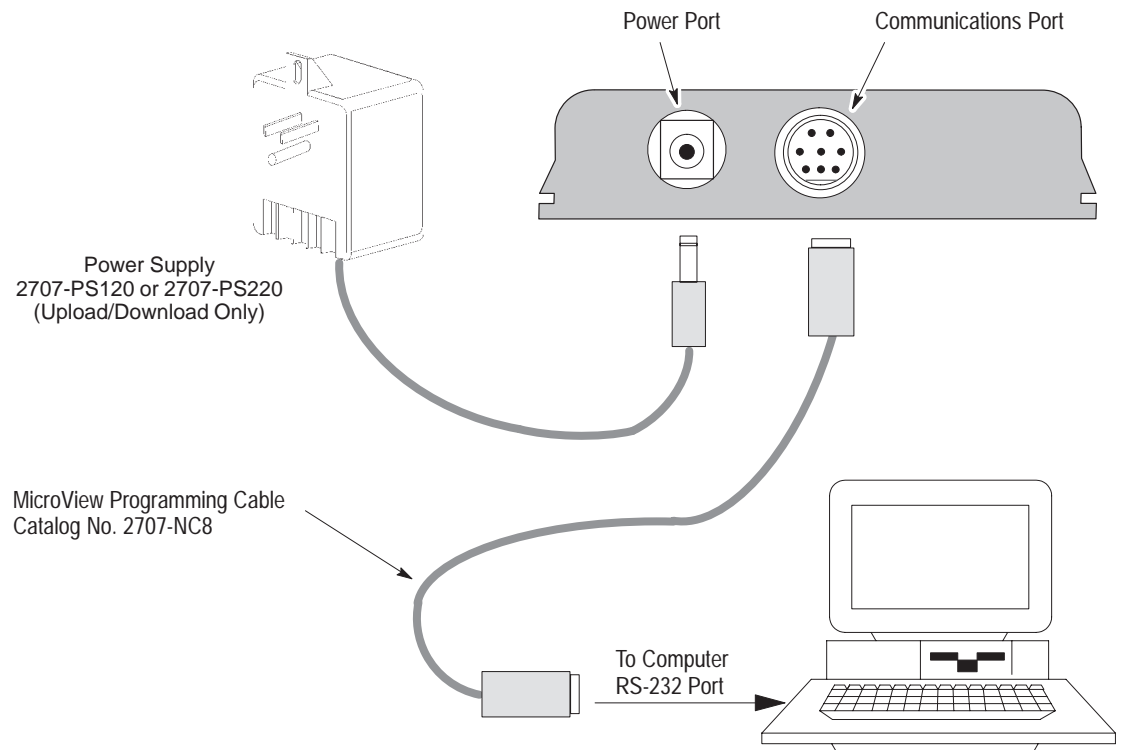

Computer Setup

Upload and download functions are initiated from a personal computer running the programming software DPS (Catalog No. 2707-NP, Version 5.00 or later) or the MicroView programming software MDPS (Catalog No. 2707-NP2, Version 1.00 or later). All data transfer functions automatically occur at 9600 Baud.

After the transfer is complete, the baud rate is set to the parameters defined by the application program residing in the MicroView.

Downloading an Application

This section shows how to download an application from a computer running DPS software (Catalog No. 2707-NP, Version 5.00) to the MicroView.

If you are using MicroView MDPS software (Catalog No. 2707-NP2, Version 1.00 or later), refer to the MicroView Programming Manual (Publication No. 2707-805) for additional information.

1. Apply power to the MicroView.
2. Place the MicroView into the Program Mode by performing these steps:
 - Press the [MODE] key to access the Mode Menu.
 - Press [3] to access Special Menu.
 - Press [3] to enter the Program Mode.
 - Press [1] for uploading/downloading function.

The following message appears in the window of the MicroView.

PROGRAMMING MODE
"MENU" to Exit

3. On your computer, move to the \DPS subdirectory where the software resides.

```
C:\DPS>
```

Note: If you are using MicroView MDPS software (Catalog No. 2707-NP2) the default subdirectory is \MDPS

4. Type **dps** and press [Return] to start the program.

```
C:\DPS>dps
```

☞ *You will not see this prompt if a monitor was specified during DPS installation.*

5. Specify whether you are using a color monitor. Enter **Y** or **N**.
6. The startup screen displays:



7. Press any key (other than [Esc]) to continue.
The Product Selection Menu appears.

☞ *You will not see this prompt if a product type was specified during DPS installation.*



8. Highlight "MicroView" and press [Return].

Downloading an Application

The Opening Menu appears.

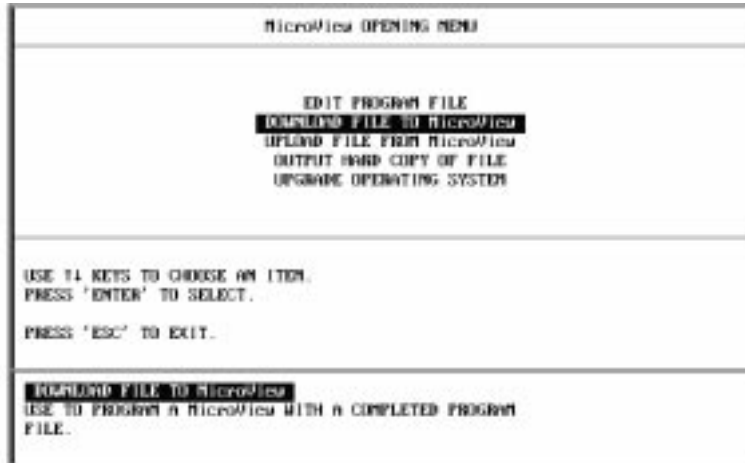

9. Highlight "Download File to MicroView" and press [Return].

The Communication Port Selection screen appears.

You will not see this screen if a communication port was specified during DPS installation.

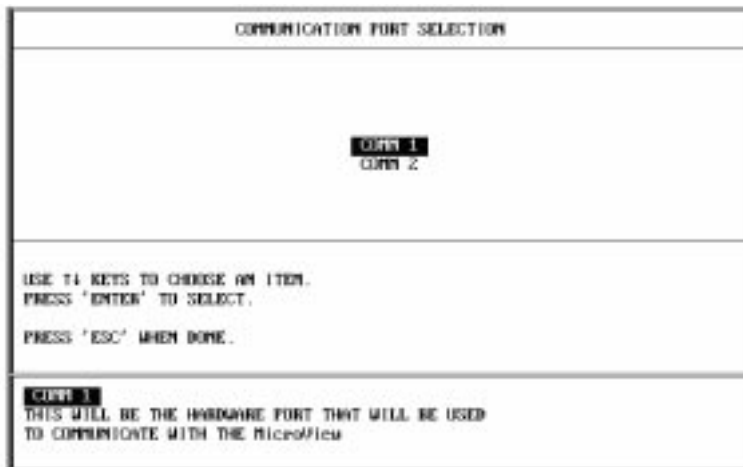

10. Highlight the serial port on your computer that is connected to the MicroView (COMM 1 or COMM 2) and press [Return].

11. When communication is established, the following screen appears:

☞ *If a communication link does not occur in 60 seconds, you get an error message. Check cable connections and verify that the MicroView is in the Program Mode.*

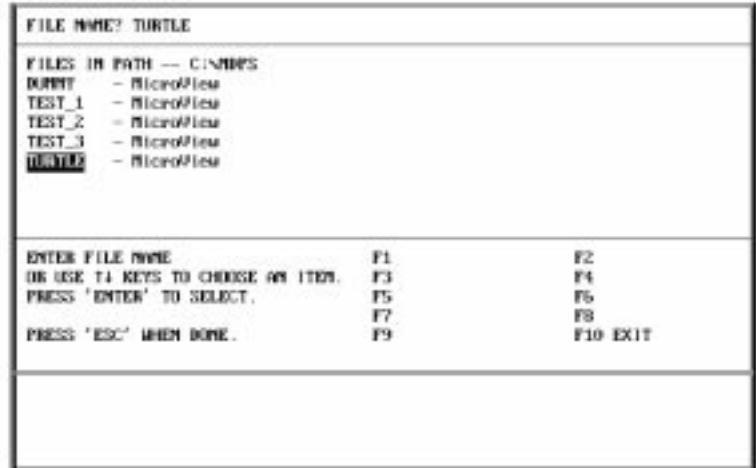

12. Enter or select the file name that you want to download.

13. Press [Return] to load the application file.

The download begins and the following screen shows the progress of the download operation.

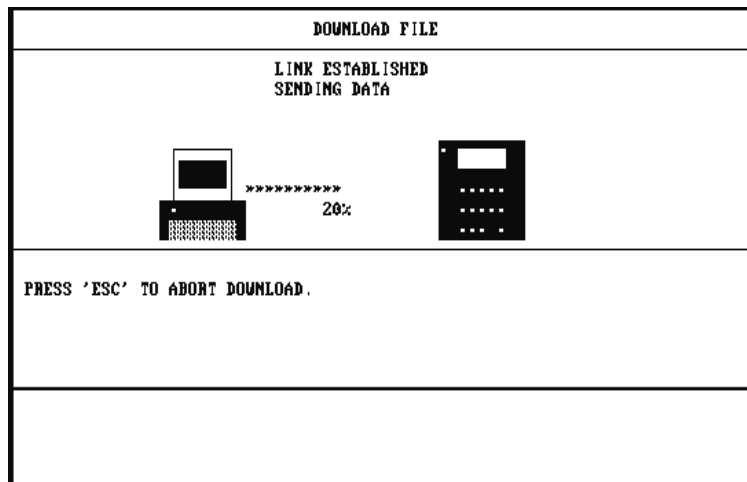

Downloading an Application

14. During the download, the MicroView alternately displays:

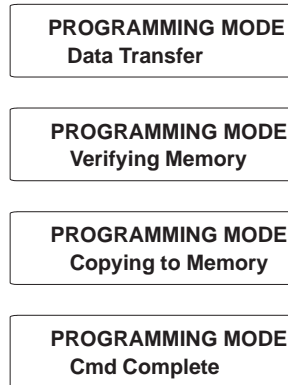

15. When the download is complete, you are returned to the Opening Menu.

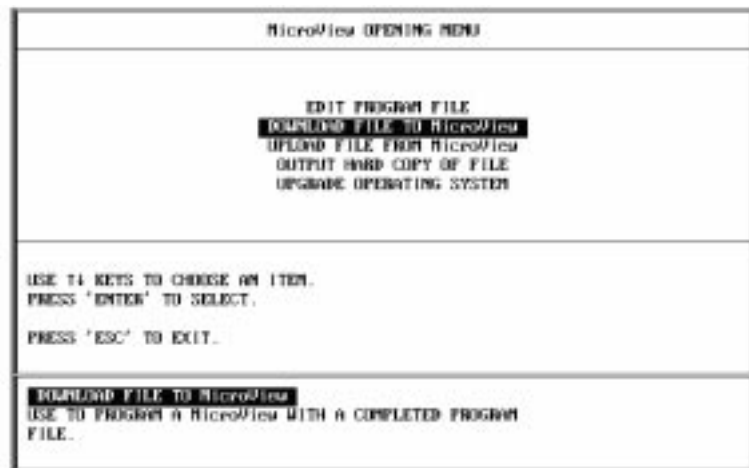

and the MicroView displays the Program Mode screen:



16. Press [Esc] to exit the software.

17. Press [Y] to return to DOS.

The application is now loaded into the MicroView. You can test the application using the simulate function described in Chapter 3 or you can run the application as described in Chapter 5.

Uploading an Application

This section shows how to upload an application to a computer running DPS software (Catalog No. 2707-NP, Version 5.00) from the MicroView.

If you are using MicroView MDPS software (Catalog No. 2707-NP2, Version 1.00 or later), refer to the MicroView Programming Manual (Publication No. 2707-805) for additional information

1. Apply power to the MicroView.
2. Place the MicroView into the Program Mode by performing these steps:
 - Press the [MODE] key to access the Mode Menu.
 - Press [3] to access Special Menu.
 - Press [3] to enter the Program Mode.
 - Press [1] for uploading/downloading function.

The following message appears in the window of the MicroView.

PROGRAMMING MODE
"MENU" to Exit

3. On your computer, move to the \DPS subdirectory where the software resides.

```
C:\DPS>
```

Note: If you are using MicroView MDPS software (Catalog No. 2707-NP2) the default subdirectory is \MDPS

4. Type **dps** and press [Return] to start the program.

```
C:\DPS>dps
```

5. Specify whether you are using a color monitor. Enter **Y** or **N**.
6. The startup screen displays:

 You will not see this prompt if a monitor was specified during installation.



Uploading an Application

You will not see this prompt if a product type was specified during installation.

7. Press any key (other than [Esc]) to continue.

The Product Selection Menu appears.



8. Highlight "MicroView" and press [Return].

The Opening Menu appears.



9. Highlight "Upload File From MicroView" and press [Return].

The Communication Port Selection screen appears.

☞ You will not see this screen if a communication port was specified during DPS installation.

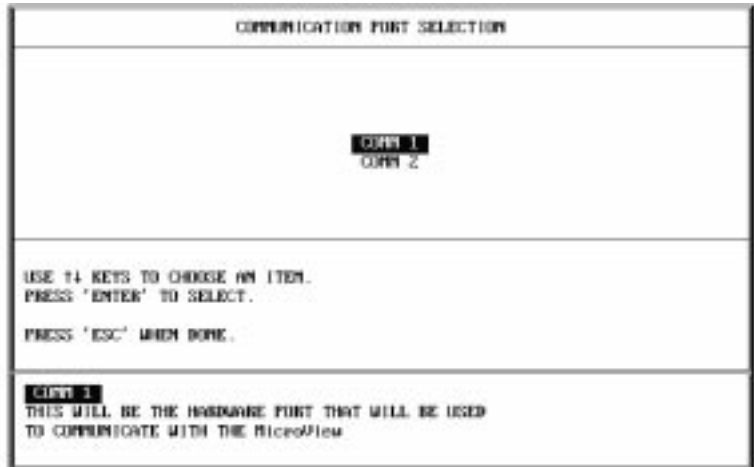

10. Highlight the serial port on your computer that is connected to the MicroView (COMM 1 or COMM 2) and press [Return].
11. When communication is established, the upload begins and the following screen shows the progress of the upload operation.

☞ If a communication link does not occur in 60 seconds, you get an error message. Check cable connections and verify that the MicroView is in the Program Mode.

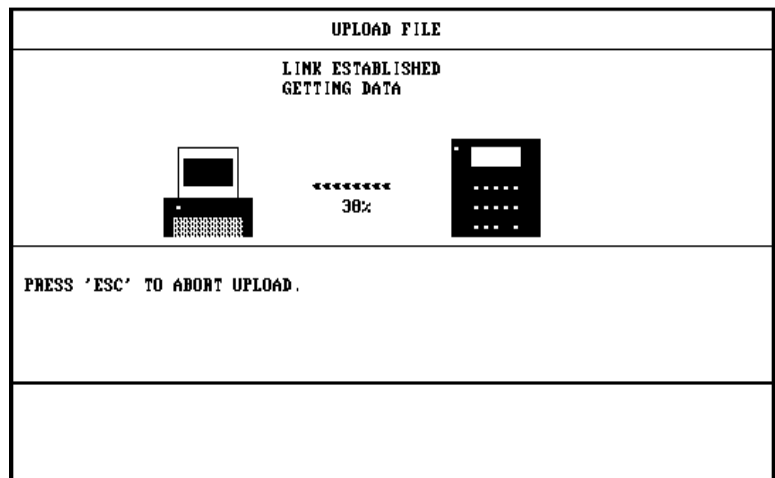

12. When the upload is completed, you are asked to enter the name that the file should be saved as. Enter up to an eight character file name and press [Return].

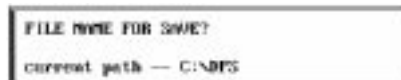

Note: Do not use a file extension. DPS adds a “.CFG” file extension to the file name.

Uploading an Application

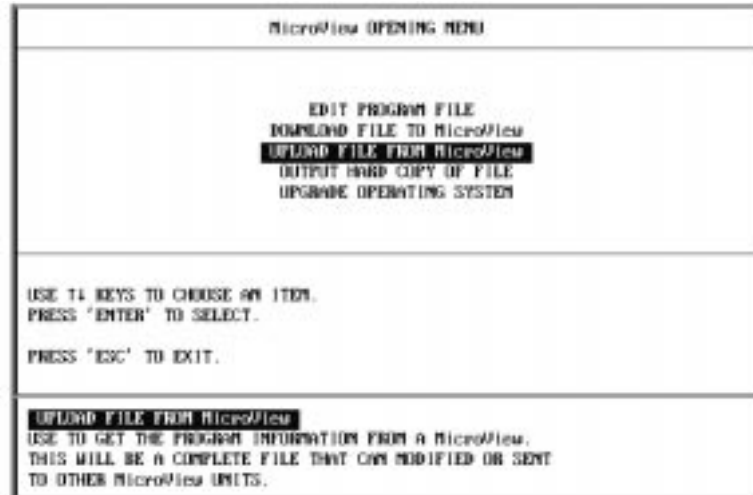

13. The program returns to the Opening Menu. Press [Esc] to exit the software.
14. Press [Y] to return to DOS.

The application is now loaded into the DPS software. To edit the application file refer to Publication No. 2707-801, if you are using DPS Programming Software, Version 5.00 or later. Refer to Publication No. 2707-805 if you are using MicroView Programming Software, Version 1.00 or later.

Running Applications

Chapter Objectives

This chapter describes screen types and operating procedures that are common to most applications. It contains the following sections:

Section	Page
Application Documentation	5-1
Bit Write Mode	5-1
Screen Navigation	5-2
Screen Types	5-2
Menu and Sub-Menu Screens	5-4
Security Screens	5-4
Data Display Screens	5-5
Data Entry Screens	5-5
Recipe Screens	5-6

Application Documentation

It is the responsibility of the application designer to document the operation of an application program. This chapter only provides basic guidelines. Before running an application, you should understand what processes are being controlled and monitored.



ATTENTION: The function keys of the MicroView can be assigned different functions depending upon the application. The application designer must document these functions. Make sure you understand any function key operations prior to operating the MicroView. Failure to do so may result in unintended operation.

Bit Write Mode

The application designer can assign the function keys [F1] and [F2] to set or clear a bit at a controller address. This bit may control a variety of processes. It is the responsibility of the application designer to document the use of the bit write mode function keys.

Screen Types

Application screens can have a variety of appearances. The MicroView can display five types of screens.

- Menu and Sub-Menu Screens
- Security Screens
- Data Display Screens
- Data Entry Screens
- Recipe Screens

Screen Navigation

The MicroView provides several options for changing the screen displays:

- Screen links
- Advisor option
- Function keys

Screen Links

Use the [NEXT] and [PREV] keys to step backward and forward through this sequence.

Main Menu and Sub-Menu screens list screens that can be accessed by pressing the assigned numeric key [1] through [8]. A typical Main Menu screen provides links to individual screens or sub-menus:

1 Pump	2 Tank
3 Mixer	4 Recipe

In the example above, pressing [2] at the Main Menu displays the status of a holding tank. Pressing [4] displays a Sub-Menu of the recipe screen options.

Advisor Option

Applications can allow screen changes that are controlled by a logic controller. When the logic controller writes a valid screen number to a specified Advisor register, the corresponding screen is displayed. The controller can initiate a screen change based upon a variety of inputs to the controller. For example, a pressure limit switch can be used to initiate the display of a pressure control screen. It is the responsibility of the application designer to document when and what screen changes may occur.

Function Keys

An application designer can link function keys [F1] and [F2] to individual screens. Pressing an assigned function key displays the function key number for approximately 0.5 seconds and then the assigned screen. It is the responsibility of the application designer to document the operations assigned to function keys. There are two function key modes:

- Auto Return
- Continue

Auto Return

Auto return function keys return to the initial display after the linked screen is executed. For example, assume that an application is displaying screen #6 and an auto return function key [F1] is linked to a recipe screen #10. When [F1] is pressed, the recipe screen #10 is displayed. After the operator downloads a new recipe on screen #10, the initial screen #6 is displayed.

The following table describes when the return to the initial screen occurs.

Function Key Linked To:	Returns to Initial Screen After:
Data Display Screen	[←] , [PREV], or [NEXT] keys are pressed
Data Entry Screen	A value is entered or [PREV], or [NEXT] keys are pressed ①
Recipe Screen	Recipe data is downloaded or [PREV], or [NEXT] keys are pressed ①

① [NEXT] or [PREV] keys abort the operation.

Continue

Continue function keys do not return to the initial display but remain at the linked screen. For example, assume that an application is displaying screen #3 and a “continue” function key [F2] is linked to a data entry screen #5. When [F2] is pressed, the data entry screen #5 is displayed. The application continues from screen #5.

Menu and Sub-Menu Screens

Menus and Sub-Menus provide a convenient method of accessing a large number of display screens.

Main Menu

Every application has a Main Menu screen. The Main Menu is the first application screen displayed after an initial power-up or reset.

1 Pump	2 Tank
3 Mixer	4 Recipe

The Main Menu provides access to the next level of screens and Sub-Menus.

To access the Main Menu, press the [MENU] key. Pressing this key at any time displays the Main Menu.

Sub-Menus

Sub-Menu screens function like the Main Menu. The only difference is that you must navigate through the other screens or use assigned function keys to access the Sub-Menus.

Security Screens

Security screens limit access to parts of an application. Although the text on a security screen may be changed by the application designer, many applications will use the default text:

LIMITED ACCESS CODE:

A security code is a series of 1 to 8 digits. Each security screen can have up to 3 code entries. Entering any one of the codes provides access.

To enter a security code, use the numeric keypad. An asterisk (*) is displayed for each number entered. Press [←] after the entire code is entered.

If a valid security code has been entered, the next linked screen is displayed. If an invalid security code has been entered, an error message appears. Once you acknowledge the error condition by pressing [←], you can re-enter the code.

Data Display Screens

Data display screens show either the actual or scaled value of a logic controller.

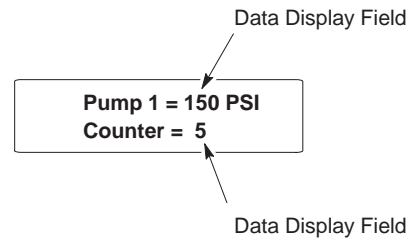

Data displays are updated at different intervals depending upon the application.

Data Entry Screens

Data entry screens contain an entry field. The length and format of the data entry field depends upon the application designer. In addition, the application designer can place a data display field on the same screen:

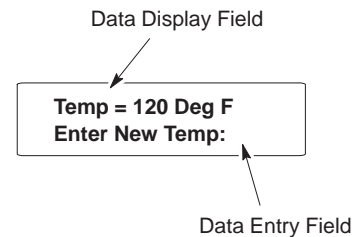

Note: The data entry field must always appear last on the screen. The application designer cannot place text after a data entry field.

To enter data, use the numeric keypad. To modify an entry, press the clear entry key [CE] and re-enter the value. Press the [+/-] key to toggle between positive and negative values. Press [↵] after the entire value is entered.

Data entry screens can have a default value appear in the data entry field. A flashing cursor identifies the first digit of the default value. Pressing [↵] writes the default to the controller or you can enter a different value by pressing the [CE] key.

Recipe Screens

Recipe screens allow the MicroView to write multiple controller addresses at the same time. Recipe screens can also be linked so that more than one recipe is downloaded.

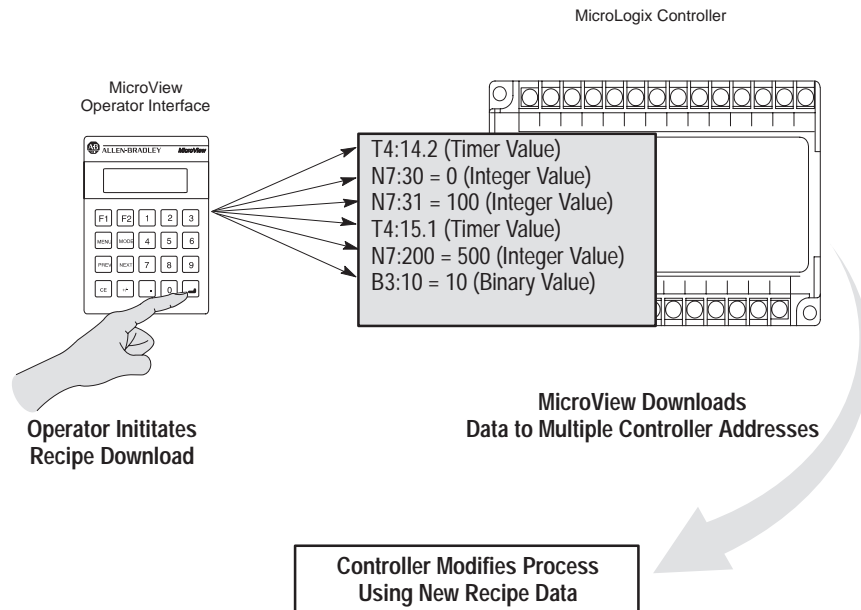

Depending upon the application designer, recipe screens will either automatically download data or display a prompt allowing the download to be initiated when [↵] is pressed.

Download Recipe?
"ENTER" to Send

Once the download is initiated, the MicroView writes the recipe data to the various controller addresses. You cannot modify the recipe data that is sent, recipe data is specified by the application designer.

Installation

Objectives

This chapter contains the following sections:

Section	Page
Safety Guidelines	6-1
Operating Environment	6-1
Enclosures	6-1
Connecting DC Power	6-2

Safety Guidelines

Install the MicroView terminal using publication NFPA 70E, Electrical Safety Requirements for Employee Workplaces as a guide.

In addition, grounding is an important safety measure in electrical installations. A source for grounding recommendations is the National Electrical Code published by the National Fire protection Association of Boston Massachusetts.

Refer to the inside front cover of this manual for additional guidelines.

Operating Environment

The MicroView is rated for an operating temperature range of 32 to 131°F (0 to 55°C). The storage temperature range is -4 to 158°F (-20 to 70°C). The humidity rating is 5 to 95% relative humidity (non-condensing).

If you are using a DC power supply, check the environmental ratings of the supply. The AC to DC Adapters (Catalog No. 2707-PS120 and 2707-PS220) are rated at 32-104°F (0-40°C).

Enclosures

The Hand-Held MicroView (Catalog No. 2707-MVH232) does not need to be mounted in an enclosure. A Faceplate Mounting Kit (Catalog No. 2707-MVMNT) is available if you wish to surface mount the Hand-Held MicroView to a panel.

Connecting DC Power

During run-time operation, the MicroView is supplied with 24 VDC power by the MicroLogix controller through the cable connected to the Communication Port.

When the MicroView is connected to a personal computer for application uploading/downloading a separate DC power source must be connected to the Power Port. The MicroView accepts power supply voltages from 11 to 25 VDC. The DC power supply must be capable of providing at least 1.5 watts.

The following MicroView accessories meet these requirements. Use either depending upon your source voltage.

- 120 VAC Input, use AC to DC Adapter (Catalog No. 2707-PS120)
- 220 VAC Input, use AC to DC Adapter (Catalog No. 2707-PS220)

To connect the communications cabling, between the MicroView and MicroLogix, refer to Chapter 7.

Communication Connections and Setup

Chapter Objectives

This chapter describes how to connect the MicroView terminal to communicate with peripheral devices. It contains the following sections:

Section	Page
Wiring Guidelines	7-1
Connecting RS-232 Devices	7-2
Communicating with a Logic Controller	7-3

Wiring Guidelines

Here are some recommendations on how to reduce noise on the communications connections:

- Careful wire routing helps reduce or minimize electrical noise. Route incoming power to the terminal by a separate path from the communications cables.
- Do not run communications wiring and power wiring in the same conduit.
- Where communications and power wiring must cross, make their intersection perpendicular.
- Proper grounding helps to limit the effects of noise due to Electromagnetic Interference (EMI). To avoid problems caused by EMI, all cables must be shielded and grounded at one end. Grounding is also an important safety measure in electrical installations.

Connecting RS-232 Devices

The RS-232 port of the MicroView terminal allows point-to-point communications with:

- A MicroLogix controller during run-time operations.
- A personal computer for application uploads and downloads. (See Chapter 4)

MicroView to MicroLogix Controller

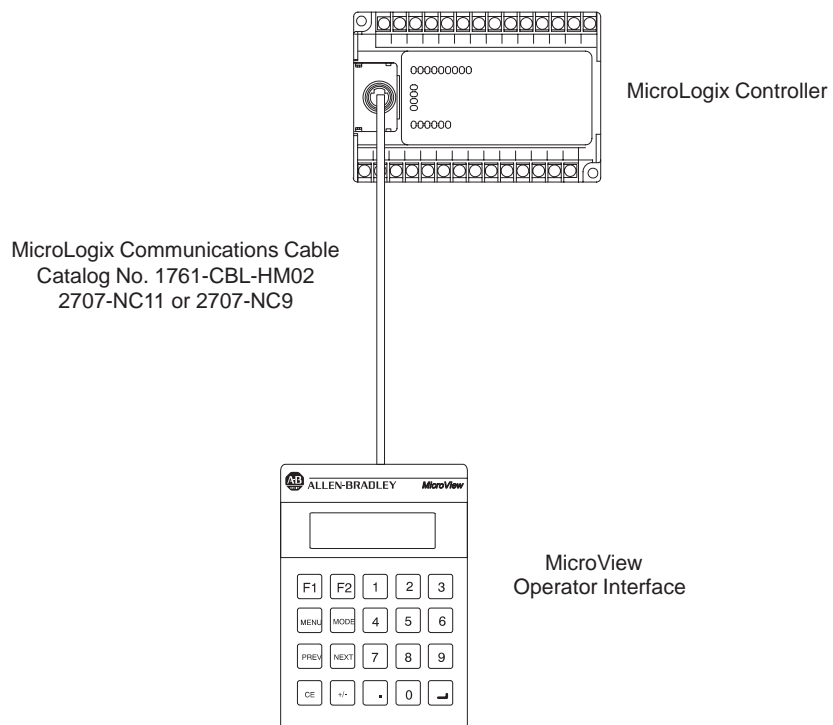

To connect the MicroView to the MicroLogix controller:

1. Use the proper cabling to connect the MicroView communications port to the port of the controller. Use cable:
 - Catalog No 2707-NC9 (15 meters).
 - Catalog No. 1761-CBL-HM02 (2 meters).
 - Catalog No. 2707-NC11 (2 meters)

If you need to make your own cable, refer to the cable diagrams in Appendix B. The maximum recommended cable length is 50 feet (15.2 meters).

2. Make sure that the communication parameters of the MicroView terminal match the MicroLogix.

Communicating with a Logic Controller

The MicroView supports communications with the MicroLogix DF1 operating system.

Applications are downloaded with the MicroLogix DF1 operating system. You cannot download an application that has a different operating system than the current operating system in the MicroView.

Communications Parameters

The communication settings of the MicroView must be set to match the MicroLogix controller. The baud rate is the only parameter that can be set for both the MicroView and MicroLogix controller.

Parameter	Selections
Baud Rate	300, 1200, 2400, 9600, 19200
Data Bits	8 (Fixed)
Parity	None (None)

Troubleshooting and Maintenance

Chapter Objectives

This chapter describes how to isolate and correct the most common operating problems and routine maintenance tasks. It contains these sections:

Section	Page
Troubleshooting Recommendations	8-1
Equipment Required	8-1
Common Operating Problems	8-2
Error Messages	8-2
Using the Test Functions	8-4
Display Test	8-5
Core ROM Test	8-5
System RAM Test	8-6
System ROM Test	8-7
Program ROM Test	8-8
Keyboard Test	8-8
Communication Port Test	8-10
Watchdog Test	8-11
Cleaning the display window.	8-12

Troubleshooting Recommendations

Most errors are accompanied by an error message. Find the error message in the error message listing and perform the recommended corrective action.

If you encounter a problem that is not listed in the table, contact your local Allen-Bradley distributor for assistance.



ATTENTION: Always disconnect power when checking wiring connections. Failure to take adequate precautions may result in severe electrical shock or equipment damage.

Equipment Required

Other than verifying that the correct power source is connected to the terminal (use a voltmeter), no electronic diagnostic equipment is required for troubleshooting.

Common Operating Problems

If there is no display on the MicroView, verify that 24 VDC is present at the 8-pin DIN connector (pins 1 and 2). If not, check the DC power from the MicroLogix controller through the communications cable.

The most common problems are related to cabling configurations and the communication parameters (baud rate, data bits, parity). These parameters must be identical for both the MicroView and the controller. Cabling and the communications parameters are always the first things to check.

If the communications cabling and communications parameters are correct, perform the diagnostic tests to rule out any non-functioning features of the MicroView.

Error Messages

Refer to the following when the MicroView displays an error message.

Message	Probable Cause(s)	Corrective Action(s)
Core ROM: FAIL Any Key to Cont.	Core ROM (boot code) checksum test failure at power-up or reset.	Possible defective ROM. Reset the MicroView and re-check. If the problem still exists, return the MicroView for repair.
FATAL ERROR Operation Halted	Core ROM checksum test failure at power-up or reset.	Possible defective ROM. Reset the MicroView and re-check. If the problem still exists, return the MicroView for repair.
Sys ROM: Fail Any Key to Cont.	Operating system checksum is incorrect.	Possible bad operating system. Reset the MicroView and re-check. If problem still exists, re-download operating system through the programming software. If the problem is not corrected, return the MicroView for repair.
Prg ROM: Fail Any Key to Cont.	Application file checksum is incorrect.	Reset the MicroView and re-check. If problem still exists, reload the application file and re-check. If problem is not corrected, return MicroView for repair..
Access Denied ENTER To Cont.	The security code entered did not match any of the 3 stored security codes in the application program.	To check for input error – try again. If security codes have been forgotten, view the application file using MicroView programming software on a PC.
Incorrect Master Code	Entered master code and stored master code did not match.	To check for input error – try again. If Master Security Code has been forgotten, view the application file using MicroView programming software on the PC.

Message	Probable Cause(s)	Corrective Action(s)
Not Programmable	Master code is 99999999 and is not user-programmable.	A master code number of 99999999 may not be programmed. Download a new, valid master code number (using MicroView Programming Software).
* Input Error * Any Key to Cont. High and low limits are displayed for one second in either of these formats: HIGH xxxxxxxxxxxx LOW xxxxxxxxxxxx HIGH LIM xxxxx LOW LIM xxxxx	The data entered is not within the programmed limits.	Verify that the displayed limits are as programmed for the entry field. Re-enter data within the entry limits.
MicroLogix DF1 Attempting Link	Attempting to communicate with a MicroLogix Controller.	Normal display when initiating communications with the MicroLogix controller.
SW/OI Mismatch **OI Locked**	An incorrect unlock code sent by MicroView Programming Software. Wrong version of MicroView Programming Software	Verify that your version of DPS Programming Software is compatible for the MicroView. (Catalog No. 2707-NP, Version 5.00 or later) or (Catalog No. 2707-NP2, Version 1.00 or later)
Com Error Code: nnH ENTER to Reset	Communication error code (nn)	Received a controller error code. Refer to next section for error codes.
Comm Fault 1=Retry 0=Reset	Communications between the MicroView and MicroLogix controller has been lost.	Pressing "1" will try to restore communications. Check cabling between MicroView and controller. Check MicroLogix controller operations.
Communication Loss Press ENTER to Reset	Communication with the controller was lost.	Check MicroView to controller cabling. Check Controller operating conditions.

Communication Error Codes

Communication Error Codes appear on the MicroView display as follows:

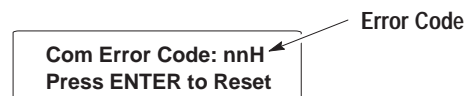

The communication error codes are displayed as a result of a remote error occurring at the MicroLogix controller. These error codes are generated by the controller and provide valuable troubleshooting information when other symptoms either have not been discovered or have not been understood.

Note: For a complete list of error codes, consult the troubleshooting section of the user manual for your MicroLogix Controller (Catalog No. 1761-6.1).

Using the Test Functions

Use the test selection screen to test or check the following:

- Reset (resets terminal, terminates test function, page 8-4)
- Display (page 8-5)
- Core ROM (page 8-5)
- Random Access Memory (page 8-6)
- System ROM (page 8-7)
- Program ROM (page 8-8)
- Keyboard (page 8-8)
- Communications port (page 8-10)
- Watchdog hardware operation (page 8-11)

To access the test functions:

1. Access the test functions from the Mode Menu.



A screenshot of a Mode Menu with four options arranged in a 2x2 grid:

1 Reset	3 Spec
2 Comm	4 Other

2. From the Mode Menu, select item 4 to display the Other Menu:



A screenshot of an Other Menu with five options arranged in two rows:

1 Code	3 Sim	5 Ex
2 Scal	4 Test	

3. From the Other Menu, select item 4 to display the test selection screen:



A screenshot of a screen titled "Diagnostic Tests" with the option "< Test Selection >" highlighted. An arrow points from the text "Current Test Selection" below to the highlighted option.

Current Test Selection

4. Use the [NEXT] and [PREV] keys to scroll through the test options. Display the test you want to perform.
5. Press [←] to initiate the test.
6. To terminate the test, press the [NEXT] and [PREV] keys to display **Reset** in the test selection area. Press [←] to reset the terminal.

Display Test

Use the display test to verify that each screen pixel is operating properly.

To perform the display test:

1. Use the [NEXT] and [PREV] keys to show Display on the test selection screen.

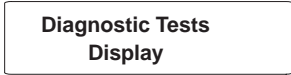

Diagnostic Tests
Display

2. Press [←] to initiate the test.

The MicroView turns all pixels on and then off. Then an alternate checkerboard pattern is displayed:



3. Press any key to terminate the test.

The next test selection screen is displayed.



Diagnostic Tests
Core ROM

4. To terminate the test function, press the [NEXT] and [PREV] keys to display **Reset** in the test selection area. Press [←] to reset the terminal.

Core ROM Test

The Core ROM checksum test verifies that the boot code stored in the Read-Only-Memory of the MicroView is correct.

To perform the Core ROM test:

1. Use the [NEXT] and [PREV] keys to display Core ROM on the test selection screen.



Diagnostic Tests
Core ROM

2. Press [←] to initiate the test.

The boot code stored in Read Only Memory is checked. If the Core ROM checksum test fails, the display shows:



Core ROM: FAIL
Any Key to Cont.

When you press any key the MicroView halts and displays:

FATAL ERROR
Operation Halted

Note: All MicroView operations will be halted after a Core ROM failure. To reset, you can attempt a power up cycle by disconnecting the communications cable from the MicroView and then reconnecting.

If the Core ROM checksum is correct, the MicroView displays:

Core ROM: PASS
Any Key to Cont.

3. Press any key to terminate the test. The next test selection screen is displayed.

Diagnostic Tests
System RAM

4. To terminate all test functions, press the [NEXT] and [PREV] keys to display **Reset** in the test selection area. Press [←] to reset the terminal.

System RAM Test

Use the RAM Read/Write test to verify the Random Access Memory of the MicroView.

To perform the System RAM Test:

1. Use the [NEXT] and [PREV] keys to display System RAM on the test selection screen.

Diagnostic Tests
System RAM

2. Press [←] to initiate the test.

The MicroView displays either a Pass or Fail message.

RAM: Test: PASS
Any Key to Cont.

3. Pressing any key terminates the RAM test.

The next test selection screen is displayed.

Diagnostic Tests
System ROM

4. To terminate all test functions , press the [NEXT] and [PREV] keys to display **Reset** in the test selection area. Press [←] to reset the terminal.

System ROM Test

The System ROM test verifies the checksum of the operating system stored in the EPROM of the MicroView.

To perform the System ROM Test:

1. Use the [NEXT] and [PREV] keys to display System ROM on the test selection screen.

Diagnostic Tests
System ROM

2. Press [←] to initiate the test.

The MicroView displays either a Pass or Fail message.

Sys ROM: PASS
Any Key to Cont.

If the test fails, the system enters the program mode. If the test passes, pressing any key returns operation to the next test.

3. Pressing any key terminates the System Memory test.

The next test selection screen is displayed.

Diagnostic Tests
Program ROM

4. To terminate all test functions , press the [NEXT] and [PREV] keys to display **Reset** in the test selection area. Press [←] to reset the terminal.

Program ROM Test

Use the Program ROM test to verify the checksum of the current application file stored in the EPROM of the MicroView.

To perform the Program ROM Test:

1. Use the [NEXT] and [PREV] keys to display Program ROM on the test selection screen.



Diagnostic Tests
Program ROM

2. Press [←] to initiate the test.

The MicroView displays either a Pass or Fail message.

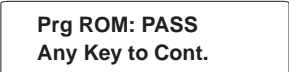

Prg ROM: PASS
Any Key to Cont.

If the test fails, the system enters the program mode. If the test passes, pressing any key returns operation to the next test.

3. Pressing any key terminates the Program ROM test.

The next test selection screen is displayed.

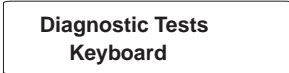

Diagnostic Tests
Keyboard

4. To terminate all test functions, press the [NEXT] and [PREV] keys to display **Reset** in the test selection area. Press [←] to reset the terminal.

Keyboard Test

Use the keyboard test to verify that the keyboard is functioning properly.

To perform the keyboard test:

1. Use the [NEXT] and [PREV] keys to display Keyboard on the test selection screen.



Diagnostic Tests
Keyboard

2. Press [←] to initiate the test.

The MicroView prompts you to press each key in a sequential order.

Press "F1"

3. Press the keys as prompted from left to right beginning at the top.

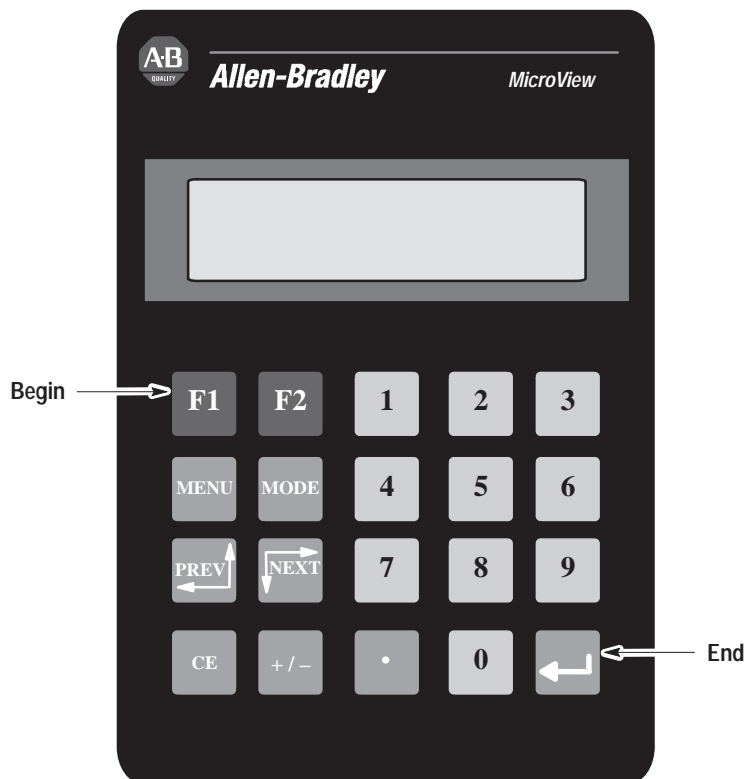

You must press all of the keys in the order prompted. If you press the wrong key, the MicroView will display:

Keyboard: FAIL
Any Key to Cont.

4. Pressing the last key in the sequence causes the MicroView to display:

Keyboard: PASS
Any Key to Cont.

5. Pressing any key terminates the KeyBoard Test.

The next test selection screen is displayed.



6. To terminate all test functions, press the [NEXT] and [PREV] keys to display **Reset** in the test selection area. Press [←] to reset the terminal.

Communications Port Test

Use the communications test to verify the operation of the MicroView communications port.

During the communications test, the MicroView must be supplied with 11 to 25 VDC through the power port. The following power adapters are recommended:

- Catalog No. 2707-PS120, MicroView 120VAC Power Adapter
- Catalog No. 2707-PS220, MicroView 220VAC Power Adapter

The communications test requires a loopback connector. You can construct a simple loopback connector as follows:

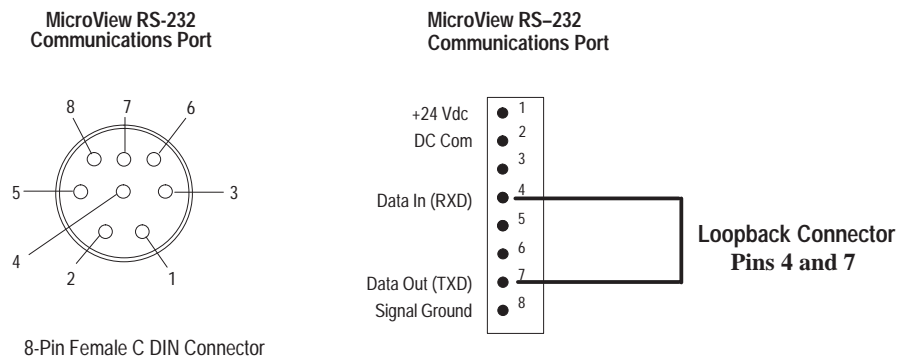

To test the communications port:

1. Connect the Loopback connector to the communications port of the MicroView (Pins 4 and 7).
2. Connect an AC to DC power adapter to the power port.
3. Use the [NEXT] and [PREV] keys to display “Comm Port” on the test selection screen.



4. Press [**←**] to initiate the test.

The MicroView will continuously send out and receive a message at the communications port and display:

COMM Self Loop
Any Key to Cont.

5. Press any key to terminate the communications test.

The MicroView displays either a Pass or Fail message.

Comm Port: PASS
Any Key to Cont.

6. Pressing any key terminates the Comm. Port test.

The next test selection screen is displayed.

Diagnostic Tests
Watchdog

7. To terminate all test functions, press the [NEXT] and [PREV] keys to display **Reset** in the test selection area. Press [**←**] to reset the terminal.

Watchdog Test

Tests the hardware watchdog operation.

To perform the Watchdog Test:

1. Use the [NEXT] and [PREV] keys to display Watchdog on the test selection screen.

Diagnostic Tests
Watchdog

2. Press [**←**] to initiate the test.

The MicroView displays either a Pass or Fail message.

Watchdog: PASS
Any Key to Cont.

3. Pressing any key terminates the Watchdog test.

The next test selection screen is displayed.

Diagnostic Tests
Reset

4. Press [←] to reset the terminal and exit the test sequence.

Cleaning the Display Window

To clean the display window:



ATTENTION: Use of abrasive cleansers or solvents may damage the window. Do not scrub or use brushes. Some types of paper towels may scratch the window, only use a soft sponge or cloth.

1. Disconnect power from the terminal at the power source.
2. Using a clean sponge or a soft cloth, clean the display with a mild soap or detergent.
3. Dry the display with a chamois or moist cellulose sponge to avoid water spots.

Removing Paint and Grease

Remove fresh paint splashes and grease before drying by rubbing lightly with isopropyl alcohol. Afterward, provide a final wash using a mild soap or detergent solution. Rinse with clean water.

Specifications

MicroView Specifications

LCD Display

Character Size (H x W)	0.22 x 0.12 in (5.56 x 2.96 mm)
Character Format	5 x 7 dot matrix
Column and Character	2 lines x 16 characters
Backlight	Yellow-green LED, fixed intensity
Contrast	Fixed
Display Viewing Area (H x W)	0.58 x 2.35 in (15mm x 60 mm)
Viewing Angle	Horizontal $\pm 30^\circ$, Vertical -20° to $+30^\circ$

Keypad

Keypad Type	Tactile embossed, domed keys, sealed membrane
Operation Force	16 oz. (453 grams)
Operational Life	1 million operations

Electrical

Communications Port	RS-232
Communication Distances	50 ft. (15 meters) maximum
Input Voltage Range	11-25 VDC, 1.5 Watt
Input Current	140 mA @ 11 Volts 60 mA @ 25 Volts

Environmental

Operating Temperature	0 to 55°C (32 to 131° F)
Storage Temperature	-20 to 70° C (-4 to 158° F)
Relative Humidity	5 to 95%, non-condensing
Shock	30G operating 50G non-operating
Agency Rating	UL, C-UL

Mechanical (Catalog # 2707-MVH232, Hand- Held)

Dimensions (Approximate)	
Height:	5.1 inch (129.5 mm)
Width:	3.55 inch (90.2 mm)
Depth:	0.975 inch (24.8 mm)

MicroView Cable Diagrams

MicroView Cables

Catalog No. 2707-NC8

Use the MicroView programming cable (Catalog No. 2707-NC8) to connect the MicroView to a PC for the uploading or downloading of application programs. The length of this cable is 2 meters.

Note: A 25 to 9 pin adapter may be required if your computer has a 25 pin communication port.

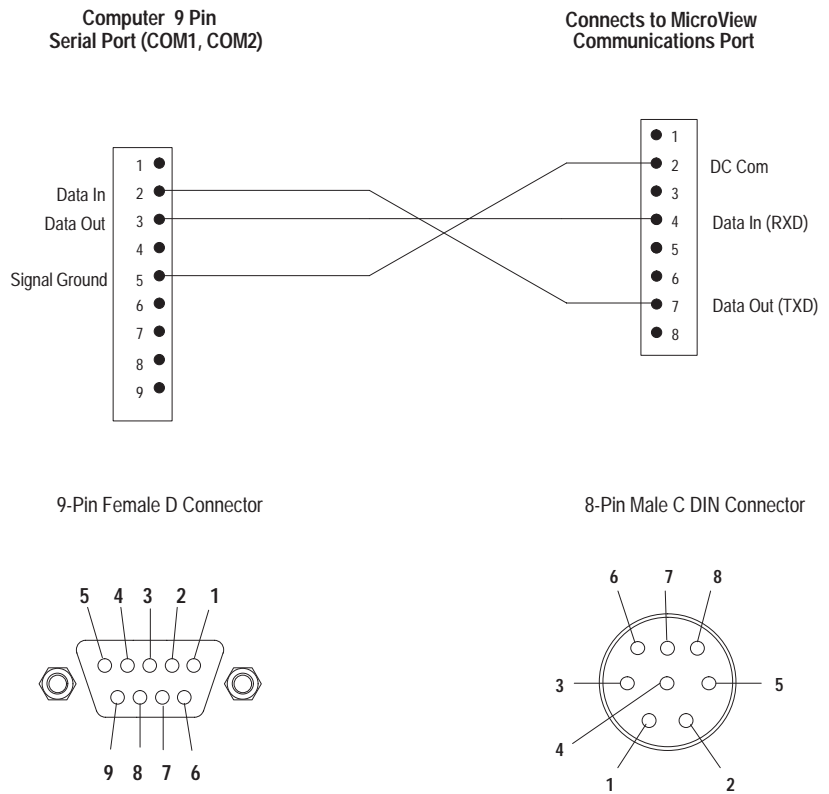

Catalog No. 2707-NC9

Use the MicroView Communications cable (Catalog No. 2707-NC9) to connect the MicroView to the MicroLogix controller for run-time operation. The cable length is 15 meters.

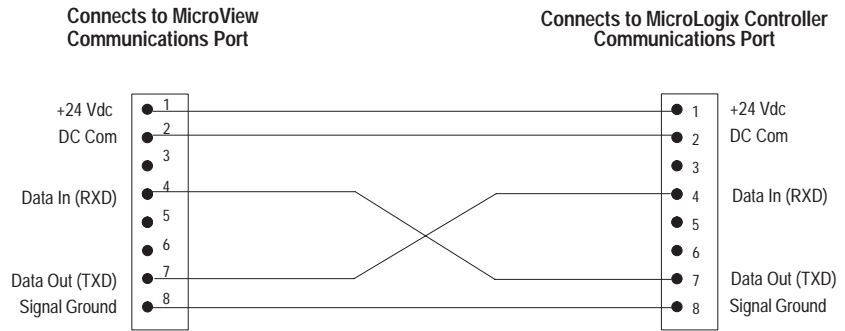

8-Pin Male C DIN Connector

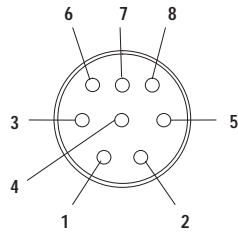

8-Pin Male C DIN Connector

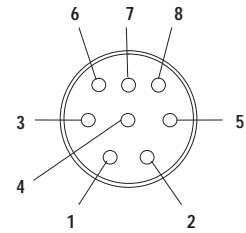

Catalog No. 1761-CBL-HM02, 2707-NC11

Use the MicroLogix communications cable to connect the MicroView to the MicroLogix controller for run-time operations. This cable is wired the same as Catalog No. 2707-NC9 except it is 2 meters long.

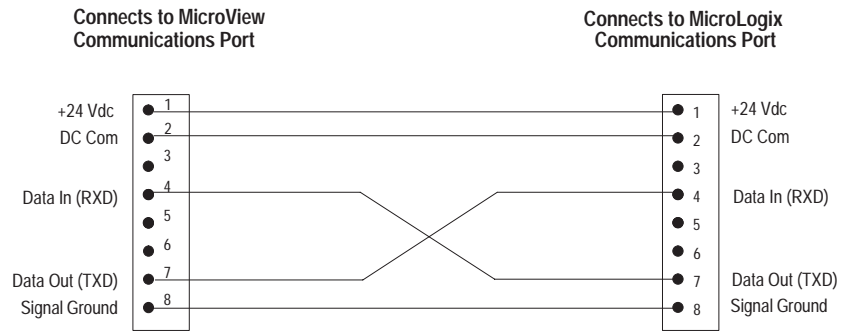

8-Pin Male C DIN Connector

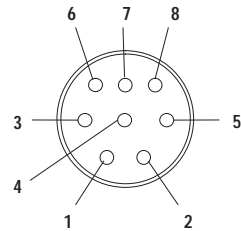

8-Pin Male C DIN Connector

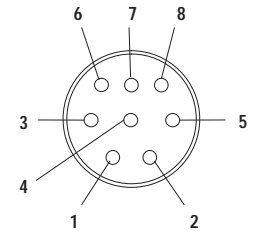

MicroView Special Controller Functions

Objectives

This appendix describes the Special Menu used to access to special features for controller operations.

Section	Page
Accessing Special Functions	C-1
Using the P-A/D Function	C-2
Reading Controller Input and Output Files	C-3
Reading / Writing Controller Status Files	C-4
Reading / Writing Controller Binary and Integer Files	C-5
Reading / Writing Controller Timer Files	C-6
Reading / Writing Controller Counter Files	C-8
Reading / Writing Controller Control Files	C-10
Using the Mode Function	C-12
Using the Program Function	C-13
Using the Clear Fault Function	C-14

Accessing Special Functions

To access the Special Menu:

Note: A security access code may be assigned in the application restricting access to the Mode Menu.

1. Select item [3] Spec from the Mode Menu to access the Special Menu:

1 Reset	3 Spec
2 Comm	4 Other

The Special Menu is displayed

1 P-A/D	3 Prgrm
2 Mode	4 Clr Fit

Accessing Special Functions

The Special Menu provides access to these functions:

1 P-A/D (Point Access/Display) refer to page C–2 for more information.

2 Mode refer to page C–12 for more information.

3 Prgrm (Program) refer to page C–13 for more information.

4 Clr Flt (Clear Fault) refer to page C–14 for more information.

Using the P-A/D Function

The P-A/D will enable the Point Access/Display function to allow you to display and change values in controller data files. The only exceptions are Input and Output files, you cannot write to these file types. The P-A/D function is often useful when starting up or debugging applications.

The following table lists the controller file types that can be accessed by the P-A/D function:

MicroLogix File Types

File Type	Identifier	File Number	Element	Read	Write
Output	O	0	0	Yes	No
Input	I	1	0 - 1	Yes	No
Status	S	2	0 - 32	Yes	Yes
Binary	B	3	0 - 31	Yes	Yes
Timer	T	4	0 - 39	Yes	Yes
Counter	C	5	0 - 31	Yes	Yes
Control	R	6	0 - 15	Yes	Yes
Integer	N	7	0 - 104	Yes	Yes

Reading Controller Input and Output Files

To read the contents of controller Input and Output files:

The input and output files are read-only files. You can view the data fields but can not change them.

1. Select item [1] P-A/D from the Special Menu to access the P-A/D function.

You are prompted for a file type:

```
Select File Type:
(O) Output
```

2. Press [NEXT] and [PREV] keys to scroll through the file types.

```
Select File Type:
(I) Input    0 - 1
```

```
Select File Type:
(O) Output
```

3. Select either Input or Output and press [←↵].

If you selected an Input file type, you are prompted to enter the element number [0 or 1] and press [←↵] to view the data in that address element.

If you selected an Output file type, the MicroView displays the data at element 0 (Zero).

```

Data Format
-----
File=l1    DEC
Elem=001   19774
Data
```

Initially, you are shown the decimal value at that address element. If you press [NEXT], the hexadecimal format is displayed:

```
File=l1    HEX
Elem=001   4D3E
```

Pressing [NEXT] again displays the binary value:

```
File=l1    Elem=001
0011111001001101
```

4. To exit, press the [CE] key to return to the initial P-A/D screen. You can press the [CE] key at any time during the P-A/D function.

```
Select File Type:
(O) Output
```

5. You can press the [MENU] key at any time to exit the P-A/D function and display the Main Menu.

Reading / Writing Controller Status Files

To read/write the contents of controller Status files:



ATTENTION: Changing control status bits may cause a processor fault or have other serious effects on the controller operation. Make sure you understand the function of status data before changing any status values.

1. Press [1] P-A/D from the Special Menu to access the P-A/D function.

You are prompted for a file type:

```
Select File Type:
(O) Output
```

2. Press [NEXT] and [PREV] keys to scroll through the file types. Select Status and press [←].

You are shown the data at a Status file element:

```
File=S2    DEC
Elem=003   5632
```

3. You can enter a new element number.

You are shown the decimal value at that address element:

```
File=S2    DEC
Elem=004   19774
```

Data Format

Data

Initially, you are shown the decimal value at that address element. If you press [NEXT], the hexadecimal format is displayed:

```
File=S2    HEX
Elem=004   4D3E
```

Pressing [NEXT] again displays the binary value:

```
File=S2    Elem=004
0011111001001101
```

4. To change a value, move the cursor into the data field using the [NEXT] or [PREV] keys. Enter the new data. If you are editing binary data, you can also use the [+/-] key to toggle the data between 1 and 0. See **Attention** above.
5. Press [←] to load the new data into the file element.
6. To exit, press the [CE] key to return to the initial P-A/D screen. You can press the [CE] key at any time during the P-A/D function.
7. Pressing the [MENU] key at any time to exit the P-A/D function and display the Main Menu.

Reading / Writing Controller Binary and Integer Files

To read/write the contents of controller Binary and Integer files:

You can read or write the element, decimal data and binary data fields of Bit and Integer files. The hexadecimal data field is read-only.

1. Press [1] P-A/D from the Special Menu to access the P-A/D function.

You are prompted for a file type:

```
Select File Type:
(O) Output
```

2. Press [NEXT] and [PREV] keys to scroll through the file types. Select either Binary (B) or Integer (N) and press [←↵].

You are prompted for an element number:

```
Elem= _____
```

3. Enter the element number and press [←↵].

You are shown the decimal value of the data:

```
File=N7   DEC
Elem=10   19774
```

Data Format

Data

Initially, you are shown a decimal value for the status. If you press [NEXT], the hexadecimal format is displayed:

```
File=N7   HEX
Elem=10   4D3E
```

Pressing [NEXT] again displays the binary value:

```
File=N7   Elem=10
0011111001001101
```

4. To change a value, move the cursor into the data field using the [NEXT] or [PREV] keys. Enter the new data. If you are editing binary data, use the [+/-] key to toggle the data between 1 and 0.
5. Press [←↵] to load the new data into the file element.
6. To exit, press the [CE] key to return to the initial P-A/D screen. You can press the [CE] key at any time during the P-A/D function.
7. Press the [MENU] key at any time to exit the P-A/D function and display the Main Menu.

Reading / Writing Controller Timer Files

To read/write the contents of controller Timer files:

1. Press [1] P-A/D from the Special Menu to access the P-A/D function.

You are prompted for a file type:

```
Select File Type:
(O) Output
```

2. Press [NEXT] and [PREV] keys to scroll through the file types. Select Timer and press [←↵].
3. You are prompted for an element number:

```
Elem= _____
```

4. Enter the element number and press [←↵].

You are shown the timer accumulator value

```
File=T4   Acc
Elem= 008 00120
```

Accumulator

Accumulated Value

5. Press [NEXT] to display the timer preset value:

```
File=T4   Pre
Elem= 008 00200
```

Preset

Preset Value

6. You can change the Acc and Pre values by pressing the [PREV] or [NEXT] keys to move the cursor to the field to change, and then entering a new value.



ATTENTION: Do not send negative timer values to the controller. Negative timer values cause a fault in the controller.

7. Press the [←] key to enter new accumulator or preset values to the displayed timer address.
8. Press [NEXT] again to display the status bits:

File=T4	EN	TT	DN	← Bits (Enable, Timer Timing, Done)
Elem= 008	0	0	0	

↙
Status

9. To exit, press the [CE] key to return to the initial P-A/D screen.
You can press the [CE] key at any time during the P-A/D function.
10. Press the [MENU] key at any time to exit the P-A/D function and display the Main Menu.

Reading / Writing Controller Counter Files

To read/write the contents of controller Counter files:

There are two types of counter files supported by the MicroLogix controller. Element 0 (Zero) is for the MicroLogix high speed counter. Elements 1 to 31 are for the standard MicroLogix counter. You can read/write the accumulator and preset values of the counter. You can not edit the status bit data files. They are read-only.

Note: Consult the MicroLogix User Manual (Catalog No. 1761 - 6.1) for a complete description of the high speed counter status bits.

1. Press [1] P-A/D from the Special Menu to access the P-A/D function.

Select File Type:
(O) Output

2. Press [NEXT] and [PREV] keys to scroll through the file types. Select Counter and press [←].
3. You are prompted for an element number:

Elem= _____

4. Enter the element number and press [←].

You are shown the counter accumulator value

File=C5	Acc
Elem= 010	02000

Accumulator
Accumulated Value

5. Press [NEXT] to display the counter preset value:

File=C5	Pre
Elem= 010	02500

Preset
Preset Value

6. You can change the Acc and Pre values by pressing the [PREV] or [NEXT] keys to move the cursor to the field to change, and then entering a new value.
7. Press the [←] key to enter new accumulator or preset values to the displayed counter address.
8. Press [NEXT] again to display the status bits:

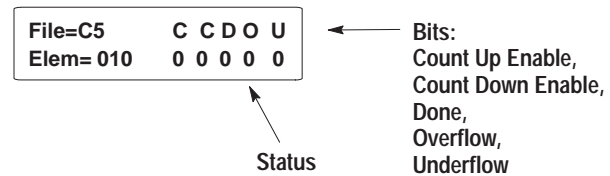

9. If you chose element C0, (High Speed Counter) , you can access two additional status bit screens. Press [NEXT] again to display:

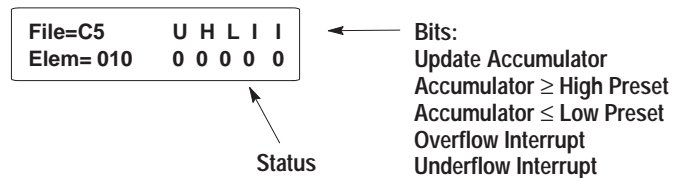

10. Press [NEXT] again to display the additional status bits.

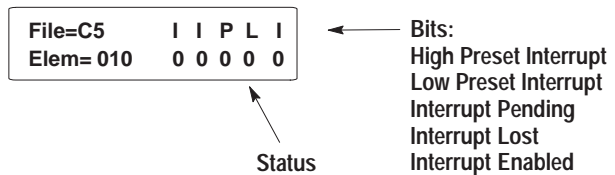

11. To exit, press the [CE] key to return to the initial P-A/D screen. You can press the [CE] key at any time during the P-A/D function.
12. Press the [MENU] key at any time to exit the P-A/D function and display the Main Menu.

Reading / Writing Controller Control Files

To read/write the contents of controller Control files:

1. Press [1] P-A/D from the Special Menu to access the P-A/D function.

You are prompted for a file type:

```
Select File Type:
(O) Output
```

2. Press [NEXT] and [PREV] keys to scroll through the file types. Select Control and press [←↵].
3. You are prompted for an element number:

```
Elem= _____
```

4. Enter the element number and press [←↵].

You are shown the length value

```

          Length
          |
          v
File=R6   Len
Elem=002  0100
          |
          v
          Value
```

5. Press [NEXT] to display the position value:

```

          Position
          |
          v
File=0 6   Pos
Elem=002  00025
          |
          v
          Value
```

6. You can change the Len and Pos values by pressing the [PREV] or [NEXT] keys to move the cursor to the field to change, and then entering a new value.
7. Press the [←↵] key to enter new length or position values to the displayed control address.

8. Press [NEXT] again to display the status bits.

The status bits for the controller are displayed on two screens. Status bits are read-only files.

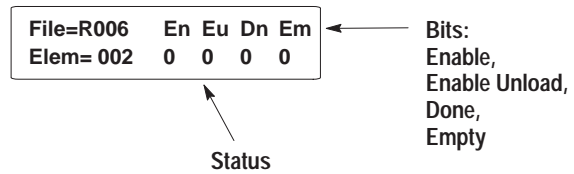

Press [NEXT] again to display the remaining status bits:

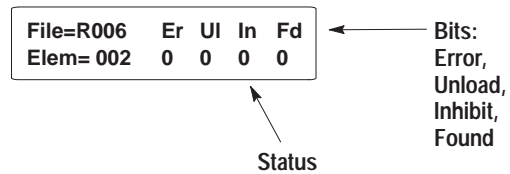

9. To exit, press the [CE] key to return to the initial P-A/D screen. You can press the [CE] key at any time during the P-A/D function.
10. Press the [MENU] key at any time to exit the P-A/D function and display the Main Menu.

Using the Mode Function

Use the Mode function to change the controller operating mode (Run or Program) from the MicroView. The mode function display is shown below:

1. Press [2] Mode from the Special Menu to access the Mode function.
2. Depending upon the current mode, you are prompted to change the controller mode:

If the controller is in Run mode:

PLC Mode = RUN
1=Prog 0=Abort

If the controller is in Program mode:

PLC Mode= PROG
1=RUN 0=Abort

3. Press [1] or [0] to enter your selection.

You are returned to the Main Menu.

Using the Program Function

The program function allows the MicroView to transfer an application program between the MicroView and an IBM™ compatible PC. Application programs can be uploaded or downloaded using the program function.

1. Press [3] Prgrm from the Special Menu to access the Program function.

1 P-A/D	3 Prgrm
2 Mode	4 Clr Flt

The MicroView displays:

1 = Upld/Dnld
0 = Abort

- [1] Sets the MicroView in the upload/download mode.
[0] Aborts the program function and return to the Special menu.
2. Press [1] to place the MicroView in the program mode.

Programming Mode "Menu" to Exit

The MicroView is now ready to upload or download application programs. Consult the MicroView Programming Software Manual (Catalog No. 2707-805) or the DTAM Programming Software Manual (Catalog No. 2707-801) for complete instructions on program transfers.

During the download, the MicroView alternately displays:

PROGRAMMING MODE Data Transfer

PROGRAMMING MODE Verifying Memory

PROGRAMMING MODE Copying to Mem

PROGRAMMING MODE Cmd Complete

3. Press [MENU] when the program transfer is completed to reset the MicroView and return to the opening menu.

PROGRAMMING MODE "MENU" to Exit

Using the Clear Fault Function

Use the Clear Fault function to clear all major and minor faults in the logic controller.

Note: The MicroLogix controller must be in the Program or Remote Program mode. Faults can not be cleared if the controller is in the Run mode.

To clear controller faults:

1. Press [4] Clr Flt from the Special Menu to access the Clear Fault function.

1 P-A/D	3 Prgrm
2 Mode	4 Clr Flt

You are prompted to clear faults:

1 = Clear Fault
0 =Abort

2. Press [1] to clear the faults or [0] to abort the function.

The faults are cleared and you are returned to the special functions menu:

1 P-A/D	3 Prgrm
2 Mode	4 Clr Flt

A

- AC Adapter, 3-2
- Accessories, MicroView, 2-8
- Adapter, AC, 3-2
- Advisor, 5-2
- Ambient Temperature, Operating, 6-1
- Application, Simulation, 3-9
- Application File
 - Documentation, 5-1
 - Downloading, 4-2
 - Transfer, 4-1
 - Uploading, 4-7
- Application Files, Running, 5-1
- Audience, Intended, 1-2
- Auto Return, 5-3

B

- Baud Rate, 7-3
- Bit File, C-5
- Bit Write Mode, 5-1

C

- Cable, Diagrams, B-1
- Chapter Descriptions, 1-1
- Chart, Troubleshooting, 8-1
- Cleaning Display, 8-12
- Clearing Faults, C-14
- Codes, Master Security, 3-7
- Communication
 - Connections, 7-2
 - Default Settings, 2-7
 - Error Codes, 8-3
 - Parameters, 7-3
 - Setting Baud Rate, 3-5
 - Upload/Download Connections, 4-1
- Communications
 - RS-232, 2-6
 - Upload/Download, 2-7
- Communications Port, 2-1, 2-3
 - Pin Identification, 2-5
 - Test, 8-10

- Connector
 - Communication, 7-2
 - Communications, 2-3
 - Loopback, 8-10
 - Power, 2-3, 6-2
- Continue Screen Changes, 5-3
- Control File, C-10
- Controller
 - Communicating With, 7-3
 - File Types, C-2
 - Mode Function, C-12
 - Screen Changes, 5-2
- Controller Mode, 3-6
- Conventions, 1-2
- Core ROM, Test, 8-5
- Counter File, C-8

D

- Data Bits, 7-3
- Data Display Screen, 5-5
- Data Entry Screen, 5-5
- Default, Application File, 2-8
- Display, 2-2
 - Cleaning, 8-12
 - Specifications, A-1
 - Test, 8-5
- Downloading, Application File, 4-2
- DPS, Upload/Download, 2-6

E

- Electrical, Specifications, A-1
- Electromagnetic Interference, Limiting, 7-1
- Environment
 - Operating, 6-1
 - Specifications, A-1
- Error Codes, Communications, 8-3
- Error Messages, 8-2

F

- Faults, Clearing, C-14

File

- Bit, C-5
- Control, C-10
- Counter, C-8
- Integer, C-5
- Status, C-4
- Timer, C-6

Function Key, Operations, 2-1, 2-4

Function Keys

- Auto Return, 5-3
- Continue, 5-3
- Screen Changes, 5-3

G**Guidelines**

- Safety, 6-1
- Wiring, 7-1

H

Humidity, Operating, 6-1

I

Initial Setup, 3-1

Input File, Reading, C-3

Installation, Guidelines, 6-1

Integer File, C-5

Intended Audience, 1-2

K

Keyboard, Test, 8-8

Keypad, 2-2, 2-3
Functions, 2-4
Specifications, A-1

L

Links, Screen, 5-2

Loopback Connector, 8-10

M

Main Menu, 5-4

Master Security Code

- Disabling, 3-7
- Entering, 3-7

Mechanical, Specifications, A-1

Memory, Number of Screens, 2-1

Menu

- Com-Port, 2-5, 3-4
- Main, 5-4
- Mode, 2-5, 3-4
- Other, 2-5, 3-4
- Special, 2-5, 3-4
- Sub, 5-4
- Test, 3-11

Messages, Error, 8-2

MicroLogix Controller, Connection, 7-2

MicroView

- Accessories, 2-8
- Description, 2-8
- Mounting Kit, 6-1

Microview, Description, 2-2

Mode

- Bit Write, 5-1
- Controller, 3-6
- Simulate, 3-9

Mode Function, Controller, C-12

Mode Key, Operations, 2-5

Mode Menu, 3-4

Mounting Kit, Hand-Held MicroView, 6-1

O

Operating Problems, 8-2

Operating System, Defaults, 2-8

Output File, Reading, C-3

P

Parity, 7-3

Personal Computer

- Connecting, 2-7
- Setup, 4-2
- Upload/Download, 2-7

Point Access/Display, C-2

- Description, 2-1, 3-6

Power, Requirements, 3-1

- Power Connection
 - AC Adapter, 6–2
 - Connecting Power, 6–2
- Power Connector, 2–3
- Power-up, Sequence, 3–2
- Problems, Operating, 8–2
- Program Function, C–13
- Program ROM, Test, 8–8
- Program Transfer, 3–6
- Programming Software
 - Description, 2–6
 - DPS or MDPS, 2–6
- Publications
 - MicroView, 1–2
 - Other, 1–2

R

- Recipe, Description, 2–1
- Recipe Screen, 5–6
- Related Publications, 1–2
- Reset, 3–5
- ROM, Test, 8–7
- RS-232, Port, 2–3

S

- Safety, Guidelines, 6–1
- Scaling, Enable/Disable, 3–8
- Screen
 - Data Display, 5–5
 - Data Entry, 5–5
 - Main Menu, 5–4
 - Navigation, 5–2
 - Recipe, 5–6
 - Security, 5–4
 - Sub-Menu, 5–4
 - Types, 5–2
- Screen Changes
 - Auto Return, 5–3
 - Continue, 5–3
 - Controller, 5–2
 - Function Keys, 5–3
- Screen Links, 5–2

- Security Code, 5–4
 - Master, 3–7
- Security Screen, 5–4
- Setup, Initial, 3–1
- Simulate Mode, 3–9
- Special Functions, C–1
- Special Menu, 3–6
 - Clear Fault, 3–6
 - Prgrm, 3–6
- Specifications, A–1
 - Cable, B–1
- Status File, C–4
- Sub-Menus, 5–4
- System RAM, Test, 8–6

T

- Temperature, Operating, 6–1
- Test
 - Communications Port, 8–10
 - Core ROM, 8–5
 - Display, 8–5
 - Keyboard, 8–8
 - Menu, 3–11
 - Program ROM, 8–8
 - RAM, 8–6
 - System Memory, 8–7
 - Watchdog, 8–11
- Test Functions, 8–4
- Timer File, C–6
- Troubleshooting, 8–1
 - Chart, 8–1
 - Equipment, 8–1

U

- Upload/Download, 3–6
 - Connections, 2–7, 4–1
- Uploading, Application File, 4–7
- Uploading/Downloading, Programs, C–13

W

- Watchdog, Test, 8–11
- Wildcard Character, 3–8



Rockwell Automation helps its customers receive a superior return on their investment by bringing together leading brands in industrial automation, creating a broad spectrum of easy-to-integrate products. These are supported by local technical resources available worldwide, a global network of system solutions providers, and the advanced technology resources of Rockwell.

Worldwide representation.



Argentina • Australia • Austria • Bahrain • Belgium • Bolivia • Brazil • Bulgaria • Canada • Chile • China, People's Republic of • Colombia • Costa Rica • Croatia • Cyprus • Czech Republic • Denmark • Dominican Republic • Ecuador • Egypt • El Salvador • Finland • France • Germany • Ghana • Greece • Guatemala • Honduras • Hong Kong • Hungary • Iceland • India • Indonesia • Iran • Ireland • Israel • Italy • Jamaica • Japan • Jordan • Korea • Kuwait • Lebanon • Macau • Malaysia • Malta • Mexico • Morocco • The Netherlands • New Zealand • Nigeria • Norway • Oman • Pakistan • Panama • Peru • Philippines • Poland • Portugal • Puerto Rico • Qatar • Romania • Russia • Saudi Arabia • Singapore • Slovakia • Slovenia • South Africa, Republic of • Spain • Sweden • Switzerland • Taiwan • Thailand • Trinidad • Tunisia • Turkey • United Arab Emirates • United Kingdom • United States • Uruguay • Venezuela

Rockwell Automation Headquarters, 1201 South Second Street, Milwaukee, WI 53204-2496 USA, Tel: (1) 414 382-2000 Fax: (1) 414 382-4444

Rockwell Automation European Headquarters, Avenue Hermann Debroux, 46, 1160 Brussels, Belgium, Tel: (32) 2 663 06 00, Fax: (32) 2 663 06 40

Rockwell Automation Asia Pacific Headquarters, 27/F Citicorp Centre, 18 Whitfield Road, Causeway Bay, Hong Kong, Tel: (852) 2887 4788, Fax: (852) 2508 1846

World Wide Web: <http://www.ab.com>