

USER'S MANUAL

PROCESS CONTROL MODULE for Regenerative Drives

(pre-mounted on RG3X0UA-PCM,
RG4X0UA-PCM, and RG5X0UA-PCM Drives)

**Model 200-0397
200-0405
200-0406**

Copyright © 1999 by
Minarik Corporation

All rights reserved. No part of this manual may be reproduced or transmitted in any form without written permission from Minarik Corporation. The information and technical data in this manual are subject to change without notice. Minarik Corporation and its Divisions make no warranty of any kind with respect to this material, including, but not limited to, the implied warranties of its merchantability and fitness for a given purpose. Minarik Corporation and its Divisions assume no responsibility for any errors that may appear in this manual and make no commitment to update or to keep current the information in this manual.

Printed in the United States of America.

Safety Warnings

- This symbol  denotes an important safety tip or warning. Please read these sections carefully prior to performing any of the instructions contained in that section.
- Have a qualified electrical maintenance technician install, adjust and service this equipment. Follow the National Electrical Code and all other applicable electrical and safety codes, including the provisions of the Occupational Safety and Health Act (OSHA), when installing equipment.
- Reduce the chance of an electrical fire, shock, or explosion by proper grounding, over-current protection, thermal protection, and enclosure. Follow sound maintenance procedures.
- **It is possible for a drive to run at full speed as a result of a component failure.** Please ensure that a master switch has been placed in the AC line to stop the drive in an emergency.
- **This drive is isolated from earth ground.** Circuit potentials are at 115 VAC or 230 VAC above earth ground. Avoid direct contact with the printed circuit board or with circuit elements to prevent the risk of serious injury or fatality. Use a non-metallic screwdriver for adjusting the calibration trimpots.



Contents

Introduction	1
Specifications	3
Dimensions	5
Installation	7
Mounting	7
Connections	10
PCM connections	10
Input voltage select switch	11
Speed adjust potentiometer connections	12
Polarity reversal switch connections	13
Calibration	15
Voltage input signal calibration	16
Current input signal calibration	18
Troubleshooting	21
Unconditional Warranty	Inside back cover

Introduction

Process control modules (PCM) are adder boards for regenerative drives (RG300, RG400, and RG500 series). PCM adder boards allow regenerative drives to accept a grounded or floating DC voltage or current signal.

This manual contains specifications, installation procedures, connections, and calibration procedures for the process control module (models 200-0397, 200-0405, and 200-0406). Refer to your regenerative drive user's manual for additional installation, operation, and troubleshooting procedures.

Specifications

Power Requirements

Line input	115VAC/230 VAC, 50/60 Hz, single phase
------------	----------------------------------------

Input Signal Ranges

Voltage signal, narrow range	-25 to +25 VDC
------------------------------	----------------

Voltage signal, wide range	-250 to +250 VDC
----------------------------	------------------

Current signal	1-5 mADC, 4-20 mADC, 10-50 mADC
----------------	---------------------------------

Input Impedance

Voltage signal	>25K ohms
----------------	-----------

Current signal, 1-5 mADC	1K ohms
--------------------------	---------

Current signal, 4-20 mADC	235 ohms
---------------------------	----------

Current signal, 10-50 mADC	100 ohms
----------------------------	----------

Output

Voltage range, max	-10 to +10 VDC
--------------------	----------------

Linearity	0.01%
-----------	-------

Process Control Module (PCM) Description

Model	Description
200-0379	Dual voltage PCM board for RG500 series drives
200-0405	115VAC PCM board for RG300 series drives
200-0406	240VAC PCM board for RG400 series drives

Note: PCM boards are pre-mounted on RG3X0UA-PCM, RG4X0UA-PCM, and RG5X0UA-PCM drives.

Dimensions

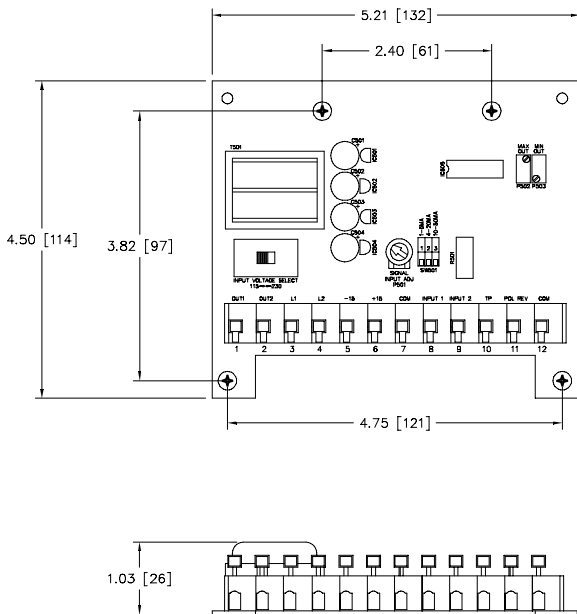

ALL DIMENSIONS IN INCHES [MILLIMETERS]

Figure 1. Process Control Module Dimensions (all models)

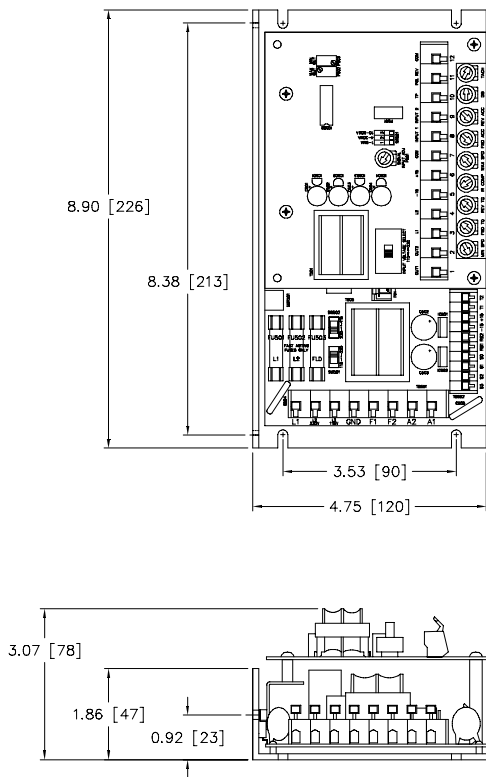

ALL DIMENSIONS IN INCHES [MILLIMETERS]

Figure 2. Process Control Module Mounted on a Regenerative Drive

Installation

Mounting

Skip these mounting steps if the PCM board is already mounted to the regenerative drive.

Step 1

Remove the 2 SCR Screws and the 2 hex nuts. Also remove the two PC board screws to the left and right of the calibration trim pots (see Figure 3).

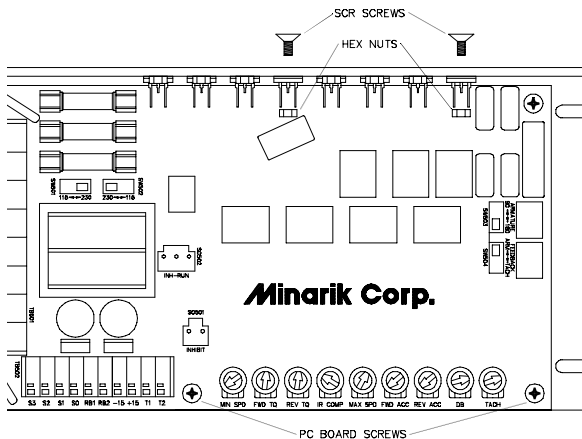

Figure 3. Mounting Step 1

Step 2

Fasten the bracket to the chassis using the SCR screws. The bracket's short standoffs replace the two hex nuts removed in Step 1. Screw in the 1.75 inch standoffs to the regenerative drive PC board (see Figure 4).

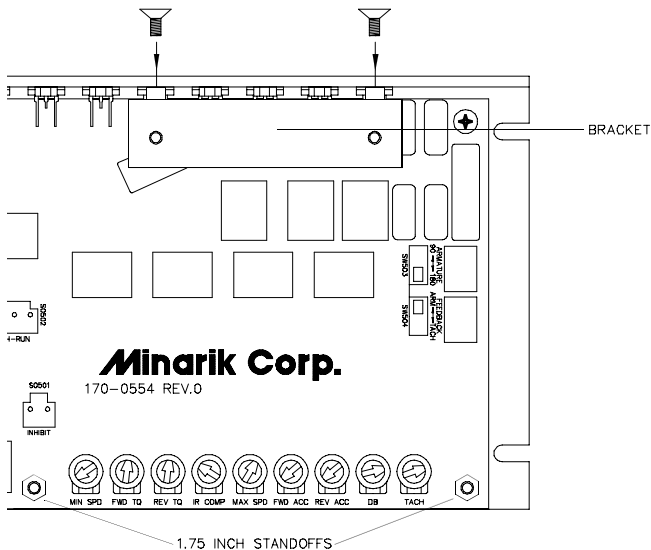

Figure 4. Mounting Step 2

Step 3

Mount the PCM board above the bracket and 1.75 inch standoffs. Secure the PCM board with four PC board screws: two unscrewed from the regenerative drive PC board in Step 1, and two included in the PCM board hardware kit (see Figure 5).

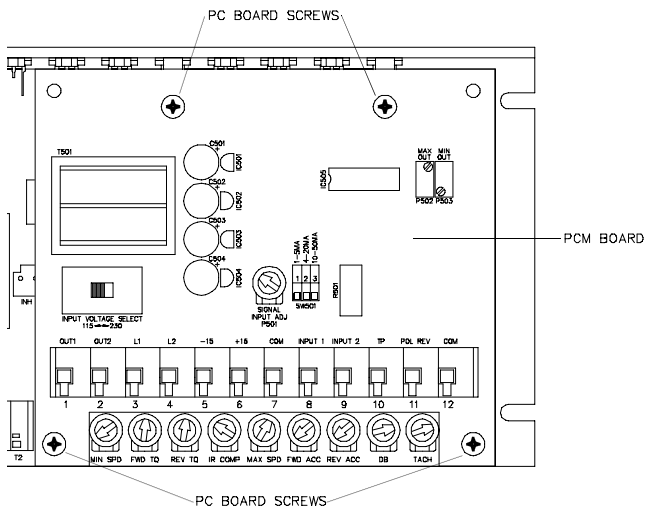

Figure 5. Mounting Step 3

Connections

PCM connections

See Figure 6 for PCM connections. PCM terminals 1 through 4 are prewired if you are using RG3X0UA-PCM, RG4X0UA-PCM, or RG5X0UA-PCM drives.

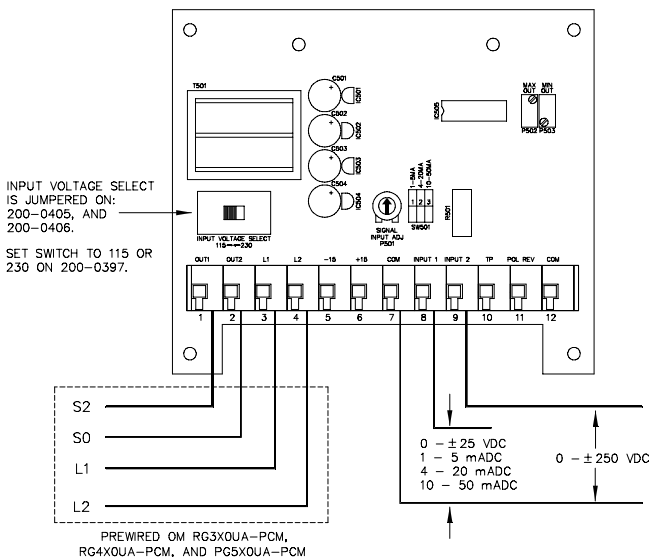

Figure 6. Process Control Module Connections

Input voltage select switch

Set the input voltage select switch to 115 or 230 to match the AC line voltage. This applies only to PCM model number 200-0392, used with RG500 series drives. See Figure 7 for switch locations.

The input voltage select switch is jumpered on PCM model number 200-0405 and 200-0406, used with RG300 and RG400 series drives, respectively. Refer to Figure 7.

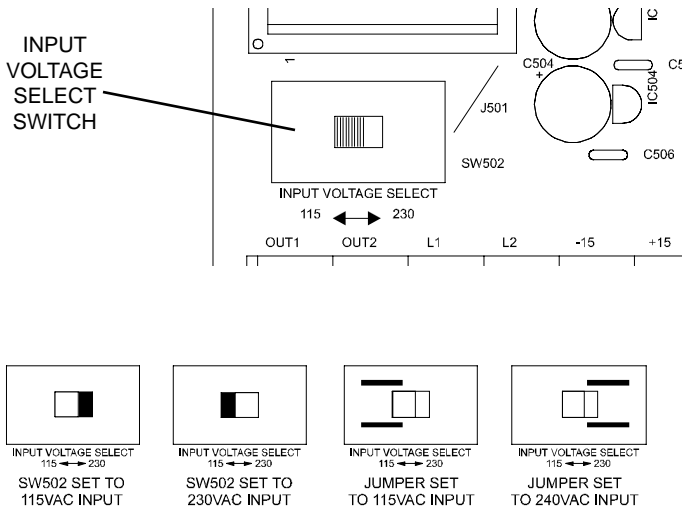

Figure 7. Input Voltage Select Switch

Speed adjust potentiometer connections

The logic board can be hooked up to speed adjust potentiometer instead of following an external current or voltage signal. To control a motor in one direction, hook up the speed adjust potentiometer as shown in Figure 8(a); for bidirectional control, use the connection in Figure 8(b).

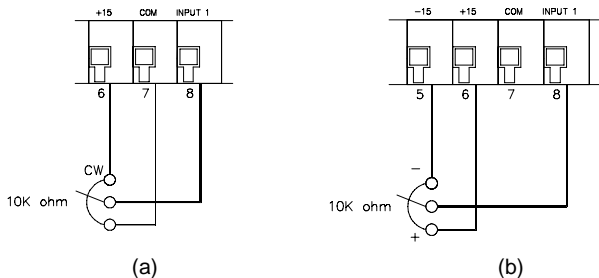

Figure 8. Speed Adjust Potentiometer Connections for (a) Unidirectional Control and (b) Bidirectional Control

Polarity reversal switch connections

To reverse the output voltage polarity without changing the input voltage (or current) polarity, connect POL REV to COM (terminal 11 to terminal 12). A single pole, single throw switch can be used as a polarity reversal switch (Figure 9). Close the switch to reverse polarity. Open the switch to return the output voltage back to its original polarity.

An open collector PNP transistor may also be used to reverse the output voltage polarity (Figure 10). Another alternative is to use an NPN transistor as shown in Figure 11 to reverse the output voltage polarity.

Note: If using an NPN transistor, additional components must be installed. Install a 39K ohm resistor in series between Terminal 11 and the transistor collector, and a 10K ohm resistor between Terminal 6 and the transistor collector as shown in Figure 11.

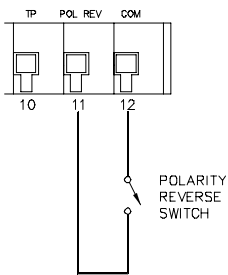

Figure 9. Polarity Reversal Switch Connection

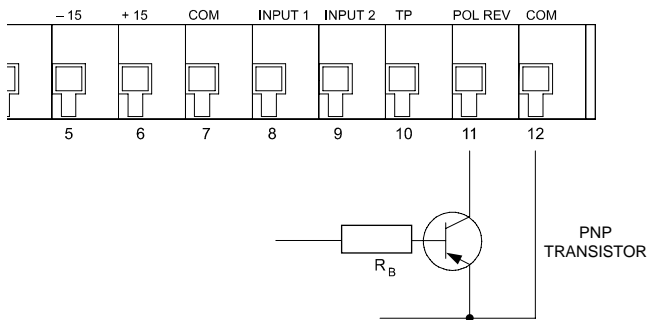

Figure 10. Open Collector PNP Transistor Used as a Polarity Reversal Switch

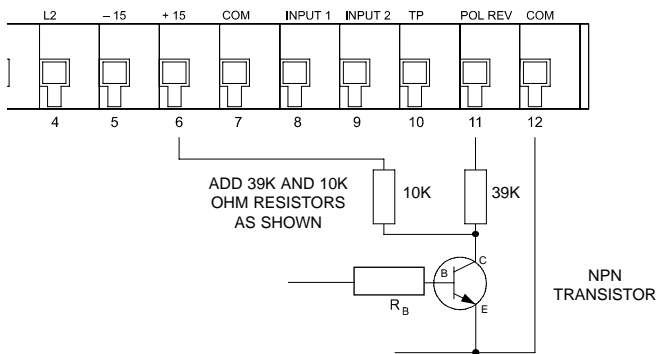

Figure 11. Polarity Reversal Using NPN Transistor

Calibration

All adjustments increase with CW rotation, and decrease with CCW rotation. Use a non-metallic screwdriver for calibration. Each trimpot is identified on the printed circuit board.

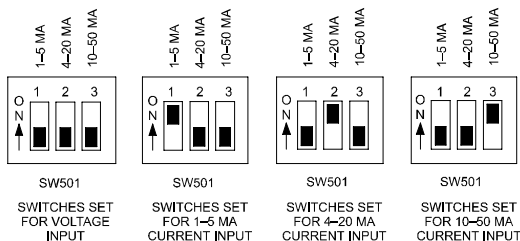
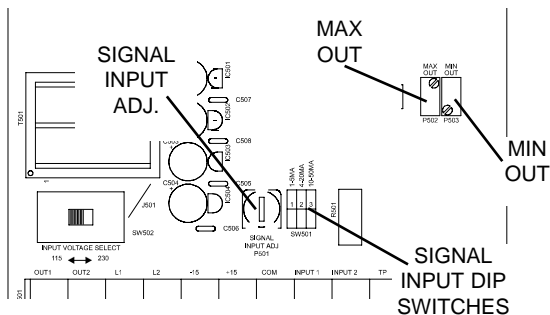

Figure 12. Calibration Trimpot and DIP Switch Layout

Voltage input signal calibration

The following maximum and minimum voltages should be known:

V_{imin} – Minimum voltage input signal.

V_{omin} – Minimum voltage output signal.

V_{imax} – Maximum voltage input signal.

V_{omax} – Maximum voltage output signal.

V_{imin} and V_{imax} is the voltage applied across terminals 7 and 8 (COM and INPUT 1) if the voltage input signal range is 0 – ± 25 VDC, or across terminals 7 and 9 (COM and INPUT 2) if the voltage input signal range is 0 – ± 250 VDC. V_{omin} and V_{omax} is the voltage across terminals 1 and 2 (OUT1 AND OUT2).

Calibration procedure

Use a voltmeter for voltage measurements.

1. Switch all three of the SW501 DIP switches OFF (Figure 12).
2. Connect the signal input as follows:
 - a. Connect signal common (–) to COM (terminal 7).
 - b. For 0 – ± 25 VDC input signal, connect the signal positive (+) to INPUT 1 (terminal 8); for 0 – ± 250 VDC input signal, connect the signal positive to INPUT 2 (terminal 9).
3. Adjust the regenerative drive's MIN SPD trimpot full CCW and the MAX SPD trimpot full CW.

4. Apply AC line voltage and voltage input signal.
5. Set the voltage input signal to $V_{i\min}$.
6. Adjust the MIN OUT trimmer potentiometer (P503) so that the output voltage is $V_{o\min}$.
7. Set the voltage input signal to $V_{i\max}$.
8. Calculate the test point voltage, V_{tp} :

$$V_{tp} = \frac{(V_{i\max}) (m)}{2}$$

where

$$m = \frac{V_{o\max} - V_{o\min}}{V_{i\max} - V_{i\min}}$$

9. Adjust the SIGNAL INPUT ADJ trimmer potentiometer (P501) so that the voltage from COM to TP (terminal 7 to 10) is V_{tp} .
10. Adjust the MAX OUT trimmer potentiometer (P502) so that the voltage output signal is $V_{o\max}$.
11. Repeat steps 4, 5, 6, 7, 9, and 10. Use the same voltage values that you previously calculated.

Current input signal calibration

The following minimum and maximum values should be known:

V_{omax} - Maximum voltage output signal

V_{omin} - Minimum voltage input signal

I_{imax} - Maximum current input signal

I_{imin} - Minimum current input signal

I_{imin} and I_{imax} is the current applied through terminals 8 and 9 (COM and INPUT 1). V_{omin} and V_{omax} is the voltage applied across terminals 1 and 2 (OUT1 and OUT2).

Calibration procedure:

Use a voltmeter and ammeter for voltage and current measurements, respectively.

1. Switch only one of the SW501 DIP switches to the ON position (Figure 12):
 - DIP switch 1 ON for 1–5 mA,
 - DIP switch 2 ON for 4–20 mA, or
 - DIP switch 3 ON for 10–50 mA.
2. Connect (but do not power) the current input signal as follows:
 - a. Connect the signal negative (–) to COM (terminal 7).
 - b. Connect the signal positive (+) to INPUT 1 (terminal 8).
3. Adjust the regenerative drive's MIN SPD trimpot full CCW and the MAX SPD trimpot full CW.
4. Apply both the AC line voltage and the current input signal.
5. Set the current input signal to I_{imin} .

- Adjust the MIN OUT trimmer potentiometer (P503) so that the output voltage is V_{omin} .
- Set the current input signal to I_{imax} .
- Calculate the test point voltage, V_{tp} :

$$V_{\text{tp}} = \frac{(I_{\text{imax}}) (m)}{2}$$

where

$$m = \frac{V_{\text{omax}} - V_{\text{omin}}}{I_{\text{imax}} - I_{\text{imin}}}$$

- Adjust the SIGNAL INPUT ADJ trimmer potentiometer (P501) so that the voltage from COM to TP (terminal 7 to terminal 10) is V_{tp} .
- Adjust the MAX OUT trimmer potentiometer (P502) so that the output voltage is V_{omax} .
- Repeat steps 4, 5, 6, 7, 9, and 10. Use the same voltage and current values that you previously calculated.

Troubleshooting

Warning!

Dangerous voltages exist on the PCM adder board and regenerative drive when it is powered. When possible, disconnect the AC line voltage from the PCM adder board and regenerative drive while troubleshooting. Be alert. High voltages can cause serious or fatal injury.

Before troubleshooting

Perform the following steps before starting any procedure in this section:

- Disconnect AC line voltage from the PCM adder board and regenerative drive.
- Check the PCM adder board and drive closely for damaged components.
- Check that no conductive or other foreign material has become lodged on the printed circuit board.
- Verify that every connection is correct and in good condition.
- Verify that there are no short circuits or grounded connections.
- Check that the input voltage select switch is set to either 115 or 230 to match the AC line voltage (model 200–0397 only).
- Check that the regenerative drive's rated armature and field outputs are consistent with the motor ratings.

If there is no output

1. Measure the voltage output signal across terminals 1 and 2 (OUT1 and OUT2). If there is a DC voltage present and there is no DC motor output, then check the connections to the regenerative drive that it is connected to.
2. Check the voltage at terminals 3 and 4 (L1 and L2). If there is no voltage then check the connections to the regenerative drive that it is connected to.
3. Check that the PCM board is receiving a voltage (or current) input signal.
4. Check to see that the SIGNAL INPUT ADJ trimmer potentiometer (P501) is not set to the full CCW position.

If the unit is running at full speed

1. Check that the voltage output signal across terminals 1 and 2 (OUT1 and OUT2) changes when the voltage (or current) input signal changes.
2. Check the wiring to the PCM board to the regenerative drive.

If the unit runs too slow or too fast

1. Check SW501 positions.
2. Check MIN SPD and MAX SPD trimpot calibrations.

If unit does not reverse

Check POL REV and COM connections.

For additional assistance, contact your local Minarik® distributor, or the factory direct at (702) 823-9475 (phone) or (702) 823-9495 (fax).

Notes

Notes

Unconditional Warranty

A. Warranty

Minarik Corporation (referred to as "the Corporation") warrants that its products will be free from defects in workmanship and material for twelve (12) months from date of manufacture thereof. Within this warranty period, the Corporation will repair or replace such products that are returned to Minarik Corporation, 901 East Thompson Avenue, Glendale, CA 91201-2011 USA.

This warranty shall not apply to any product that has been repaired by unauthorized persons. The Corporation is not responsible for removal, installation, or any other incidental expenses incurred in shipping the product to and from the repair point.

B. Disclaimer

The provisions of Paragraph A are the Corporation's sole obligation and exclude all other warranties of merchantability for use, express or implied. The Corporation further disclaims any responsibility whatsoever to the customer or to any other person for injury to the person or damage or loss of property of value caused by any product that has been subject to misuse, negligence, or accident, or misapplied or modified by unauthorized persons or improperly installed.

C. Limitations of Liability

In the event of any claim for breach of any of the Corporation's obligations, whether express or implied, and particularly of any other claim or breach of warranty contained in Paragraph A, or of any other warranties, express or implied, or claim of liability that might, despite Paragraph B, be decided against the Corporation by lawful authority, the Corporation shall under no circumstances be liable for any consequential damages, losses, or expense arising in connection with the use of, or inability to use, the Corporation's product for any purpose whatsoever.

An adjustment made under warranty does not void the warranty, nor does it imply an extension of the original 12-month warranty period. Products serviced and/or parts replaced on a no-charge basis during the warranty period carry the unexpired portion of the original warranty only.

If for any reason any of the foregoing provisions shall be ineffective, the Corporation's liability for damages arising out of its manufacture or sale of equipment, or use thereof, whether such liability is based on warranty, contract, negligence, strict liability in tort, or otherwise, shall not in any event exceed the full purchase price of such equipment.

Any action against the Corporation based upon any liability or obligation arising hereunder or under any law applicable to the sale of equipment or the use thereof, must be commenced within one year after the cause of such action arises.

Minarik Corporation

901 E Thompson Avenue
Glendale, CA 91201-2011

Tel: (702) 823-9475

Fax: (702) 823-9495

www.minarikcorp.com

Document number 250-0214, Revision 2

Printed in the U.S.A – 4/99

U.S.A. \$10.00, Canada \$11.00