

# RetroSound®

## Radio MODEL TWO Installation and Owner's Manual



AM/FM Radio with iPod® / iPhone®, USB MP3 / WMA Playback  
and InfiniMount Shaft / Bracket System

Retro Manufacturing, LLC

Model Two

**TABLE OF CONTENTS**

---

---

Licensing..... 4

Welcome! ..... 4

What’s in the Box ..... 5

Warnings and Precautions..... 6

Installation Warnings..... 9

Installation Instructions..... 11

Wiring Instructions ..... 15

Using Your Radio (Basic Operation) ..... 17

Adjusting Sound Properties ..... 21

Sub-Menu System (Right Knob)..... 24

USB Device Instructions..... 28

Bluetooth Instructions..... 30

Troubleshooting ..... 32

Frequently Asked Questions..... 33

Specifications..... 36

Limited Warranty..... 37

## LICENSING

"Made for iPod®" and "Made for iPhone®" mean that an electronics accessory has been designed to connect specifically iPod® or iPhone® respectively, and has been certified by the developer to meet Apple performance standards. Apple is not responsible for the operation of this device or its compliance with safety and regulatory standards. Please note that the use of this accessory with iPod® or iPhone® may affect wireless performance. Apple is not responsible for the operation of the device or its compliance with safety and regulatory standards.

iPod® or iPhone® are trademarks of Apple inc., registered in the U.S. and other countries. Windows Media and the windows logo are trademarks, or registered trademarks of Microsoft Corporation in the United States and / or other countries.

The Bluetooth® word mark and logos are owned by the Bluetooth SIG, inc. and any use of such marks by Retro Manufacturing, LLC is under license. Other trademarks and trade names are those of their respective owners.

### Confirmed devices regarding Made for iPod®

(Correct function of earlier versions cannot be guaranteed.)

iPod touch (4th generation): Ver. 5.1.1

iPod touch (2nd generation): Ver. 4.2.1

iPod touch (3rd generation): Ver. 5.1

iPod nano (6th generation): Ver. 1.1

iPod nano (5th generation): Ver. 1.0.2

iPod nano (4th generation): Ver. 1.0.4

iPod nano (3rd generation): Ver. 1.1.3

iPod classic (160 GB) (Late 2009): Ver. 2.0.4

iPod classic (120 GB): Ver. 2.0.1

iPod classic (80 GB, 160 GB): Ver. 1.1.2

### Confirmed devices regarding Made for iPhone®

(Correct function of earlier versions cannot be guaranteed.)

iPhone 4S: Ver. 5.1.1

iPhone 4: Ver. 5.1.1

iPhone 3GS: Ver. 5.1.1

iPhone 3G: Ver. 4.2.1

For clarity in identifying your model iPod®, please see Apple's own document "Identifying iPod models" at <http://support.apple.com/kb/HT1353>.

## WELCOME!

The RetroSound® "Model Two" radio is the answer for enthusiasts who want to maintain the classic in dash look of the vehicle and enjoy convenient playback capabilities from today's modern digital sources. The radio features AM / FM Tuner, RDS, Bluetooth® A2DP and hands free operation, iPod® / iPhone® compatible, USB inputs and subwoofer output, among its many innovative features.

This is a breakthrough classic car radio offering authentic classic style push buttons and flexible mounting options with our Patented "InfiniMount" shaft / bracket system. Connect, play and charge your iPod® or iPhone® directly from the radio with no additional adapters necessary.

### General Features

- Compatible with iPod® and iPhone®
- Built-in Bluetooth® for hands-free calling and audio streaming
- Plays MP3 and WMA files via USB input
- Selectable 32,000 color LCD illumination with user presets
- AM/FM tuner with 30 presets and RDS
- Selectable USA/EU/Japan tuner frequencies
- New shaft system featuring rear knob functionality
- Authentic push-button styling
- Built-in amplifier (25 watts RMS/45 watts peak x 4 channels)
- Two sets of RCA low level outputs
- InfiniMount shaft/bracket system for maximum installation flexibility
- Compatible with all RetroSound® vehicle specific bezel, plate and knob kits
- Two year parts and labor warranty
- Audio Features

### Audio Features

- 3 EQ presets plus user-controlled bass, treble, fader, mid-range and balance adjustment with detailed subwoofer adjustments
- XBAS loudness control

### Expandability

- Inputs: Two rear-mounted standard USB port and 2 rear auxiliary inputs
- Outputs: Six-channel pre-amp outputs (front, rear, subwoofer)
- Separate power antenna and amp turn-on lead(s)

## WHAT'S IN THE BOX

The accessory items and hardware shown below are packaged with your "Model Two" radio.



Main Harness  
(Connection on the back of the radio)

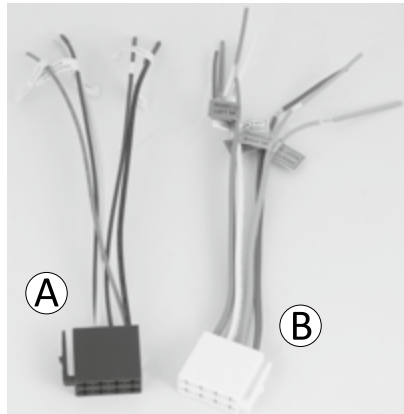

Power Wire Harness (A)  
Speaker Wire Harness (B)



Shaft/Bracket Mounting Hardware



Shaft Mounting Guide (4)



Shaft Covers (2)



Bluetooth  
Microphone



Removable InfiniMount  
Shafts (2)



Metal Mounting  
Backstrap and Hardware



InfiniMount "L" Brackets (2)

## WARNINGS AND PRECAUTIONS

This equipment has been tested and found to comply with the limits for a Class B device, pursuant to Part 15 of the FCC Rules. These limits are designed to provide reasonable protection against harmful interference in a residential installation. This equipment generates, uses and can radiate radio frequency energy, and, if not installed and used in accordance with instructions, may cause harmful interference with radio communications. However, there is no guarantee that radio interference will not occur in a particular installation. If this equipment does cause harmful interference to radio or television reception, which can be determined by turning the equipment off and on, the user is encouraged to consult the dealer or an experienced radio/TV technician for help. You are cautioned that any changes or modifications not expressly approved in this manual could void your authority to operate this equipment.

### Observe these warnings and precautions when using this unit:

- **Carefully read this manual before using the unit.** If you encounter any problems that are not covered in this manual, please consult the dealer from which you purchased the unit or the dealer nearest you. You may also email us at [support@retrosoundusa.com](mailto:support@retrosoundusa.com).
- **Do not turn the unit on if the temperature inside the car is very high.** Always allow the unit to cool down before usage.
- **The driver should neither watch the display nor operate the system while driving.** Watching the display or operating the system will distract the driver from driving safely and can cause accidents. Always stop the vehicle in a safe location and use the parking brake before watching the display or operating the system.
- **Use the proper power supply.** This product is designed for operation with a negative ground 12V DC battery system. Never operate this product with other battery systems, especially a 24V DC battery or positive ground system.
- **Do not disassemble or modify the unit.** Do not disassemble, modify the unit or attempt to repair the product yourself. If the product needs to be repaired, consult your dealer or Retro Manufacturing directly.
- **Do not use the unit when it is out of order.** If the unit is out of order (no power, no sound) or in an abnormal state (has foreign objects in it, is exposed to water, is smoking, or smells), turn it off immediately and consult your dealer.
- **Refer fuse replacement to qualified service personnel.** When the fuse blows out, eliminate the cause and have it replaced with the fuse prescribed for this unit by a qualified service technician. Incorrect replacement of the fuse may lead to smoke, fire, and damage to the product.
- **If the unit does not turn on, check the connections first.** Then, check whether the fuse in your vehicle's fuse box is blown and check the fuse at the unit's wiring harness.

**Observe these warnings and precautions during installation:**

- **Do not expose the unit to direct sunlight or excessive heat.** Excessive heat will raise the interior temperature of the unit, which may damage the unit.
- **Do not use the product where it is exposed to water, moisture, or dust.** Exposure of the unit to water, moisture, or dust may lead to smoke, fire, or other damage to the unit and void your warranty. Make sure that the unit does not get wet in car washes or on rainy days.
- **Refer wiring and installation to qualified service personnel.** Installation of this unit requires special skills and experience. For maximum safety, have it installed by your dealer. Retro Manufacturing is not liable for any problems resulting from your own installation of the unit. Please be sure to follow our instructions carefully before attempting installation.
- **Follow the instructions to install and wire the product.** Not following the instructions to properly install and wire the product could damage the unit or cause an accident or fire.
- **Disconnect the lead from the negative (-) battery terminal before installation.** Wiring and installation with the negative (-) battery terminal connected may cause electrical shock and injury due to a short circuit. Some cars equipped with the electrical safety system have specific procedures for battery terminal disconnection. FAILURE TO FOLLOW THIS PROCEDURE MAY LEAD TO THE UNINTENDED ACTIVATION OF THE ELECTRICAL SAFETY SYSTEM RESULTING IN DAMAGE TO THE VEHICLE AND PERSONAL INJURY OR DEATH.
- **Take care not to damage the leads.** When wiring, take care not to damage the leads. Prevent them from getting caught in the vehicle chassis, or from being damaged by screws or moving parts, such as seat rails. Do not scratch, pull, bend or twist the leads. Do not run them near heat sources or place heavy objects on them. If leads must be routed around sharp metal edges, protect the leads by winding them with vinyl tape or similar protection.
- **Use the designated parts and tools for installation.** Use the supplied or designated parts and appropriate tools to install the product. The use of parts other than those supplied or designated may result in internal damage to the unit. Faulty installation may lead to an accident, malfunction or fire.
- **Never use safety-related components for installation, grounding, and other such functions.** Do not use safety-related vehicle components (fuel tank, brake, suspension, steering wheel, pedals, airbag, etc.) for wiring or fixing the product or its accessories.
- **In the case of installation to an airbag-equipped car, confirm warnings and cautions of the vehicle manufacturer before installation.**
- **Check for piping, gasoline tank, electric wiring, and other items before installing the product.** If you need to open a hole in the vehicle chassis to attach or wire the

product, first check where the wire harness, gasoline tank, and electric wiring are located. Then open the hole from outside if possible.

- **Never install the product in a location where it interferes with your field of vision.**
- **Never have the power cord branched to supply other equipment with power.**
- **After installation and wiring, you should check the normal operation of other electrical equipment.** The continuation of their use in abnormal conditions may cause fire, electrical shock or a traffic accident.
- **Make sure the leads do not interfere with driving or getting in and out of the vehicle.**
- **Insulate all exposed wires to prevent short circuiting.**
- **Do not operate the unit for a prolonged period with the engine turned off.** Operating the audio system for a long period of time with the engine turned off will drain the battery.

## INSTALLATION WARNINGS



To ensure proper operation of this RetroSound product, please read these instructions carefully before installing and using this equipment.

This Owner's manual does not cover all possible installation scenarios. If you feel you can't install this product yourself, please take it to a local car audio professional, or contact us at support@retrosoundusa.com or call 909-364-1372 | 888-325-1555.



**IMPORTANT! PLEASE NOTE THAT THIS UNIT REQUIRES +12V TO BOTH THE RED & YELLOW WIRES, OTHERWISE THE UNIT WILL NOT OPERATE. CONTACT US IF YOU HAVE QUESTIONS.**



**Disconnect the negative (-) battery cable before beginning installation.** Verify the battery ground by checking that one wire is connected to the starter mounting bolt or engine block and another to the vehicle chassis using at least #8 gauge wire. Make sure the alternator connections are secure and free from corrosion, rust or dirt.



**WARNING! To prevent damage to the unit, do not connect the power connector until you have completed the wiring process. This is a 12 Volt negative-ground ONLY radio. If you have a positive ground system, or a 6-volt system, you need to either convert to 12 volts or purchase a separate inverter that would step up the voltage to 12 volts. Please note that the inverter needs to be rated at 8 amps or higher in order for the "Model Two" to operate properly.**

## PREPARING TO INSTALL

The "Model Two" radio is available with an optional set of knobs and a faceplate (for the front of the dash) or bezel (mounts from behind the dash) that fits around the control face of your "Model Two" radio. Please contact us at support@retrosoundusa.com regarding a multi-purpose or vehicle-specific faceplate/bezel and knob kit for your car. Below are examples of some of the optional dash bezels and faceplate adapters available.

	<p>1968-85 VW/Porsche/Jaguar/BMW faceplate (mounts on top of the dash). This solution shown with our exclusive all metal chrome Euro style knobs.</p>
	<p>1970-72 Chevelle bezel (mounts from behind the dash). This solution shown with our exclusive all metal GM style chrome knobs.</p>
	<p>1964-66 Ford Mustang bezel (mounts from behind the dash). This solution shown with our exclusive all metal chrome knobs.</p>
	<p>1959 Cadillac car bezel (mounts from behind the dash). The shafts have been placed on the left side, highlighting the unique installation possibilities of this system.</p>

## INSTALLATION INSTRUCTIONS

**NOTE:** Getting the unit to fit perfectly into your dash is probably the most difficult portion of the install. Patience and persistence is the key. If you still have problems, please contact us at [support@retrosoundusa.com](mailto:support@retrosoundusa.com) or 909-364-1372.

The InfiniMount system offers nearly unlimited installation options to accommodate your fit needs.

To begin, locate the removable InfiniMount shaft system and the InfiniMount "L" brackets, as well as two each large and small washers (see "What's in the Box" on page 6).

### STEP 1: Install InfiniMount Brackets

1. Attach each InfiniMount bracket using the supplied screws. Before tightening, adjust the brackets forward or backward, or rotate to achieve the perfect fit. Complete the assembly with 2 or 4 screws tightened on either side.

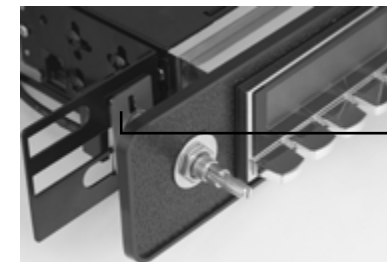

Figure 1 - Attach InfiniMount Brackets

**NOTE:** You can move our brackets forward or backward and move them in any direction. You can even cut, trim or bend the bracket or create your own bracket for a more challenging installation.

### STEP 2: Mount Shafts to Brackets

1. To match the InfiniMount shaft and bracket system to the proper shaft width of your vehicle, first measure the distance between your existing shaft holes from center to center.
2. Mount a shaft system to each bracket using the supplied shaft nuts and a shaft mounting guide.
3. Finger tighten to prepare for the final installation (see Figure 2).



Shaft Mounting Guide with Washer(s) and Nut(s)

Figure 2 - Mount Shaft to Bracket

4. Once sure of the proper width, tighten prior to final installation. Be sure to plug the shafts into each side of the main unit to activate the shaft-control functions (see Figure 3). (NOTE: Each of the shafts can operate on either side of the radio and are not left/right dependant.)

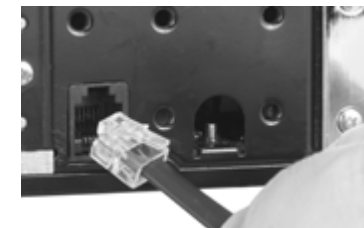

Figure 2 - Mount Shaft to Bracket

**NOTE:** Modifying or cutting the radio's brackets will not void your warranty. The system is designed to accommodate any installation scenario.

### STEP 3: Complete Wiring Connections

See "Wiring Instructions" on page 16.

## STEP 4: Adjust to Fit Your Vehicle Specific Kit

One of the most frequent questions we get is "How can your radio fit my car?" The "Model Two" radio is a universal solution (one chassis for most vehicles) and its control face is a fixed size (3.5" W x 1.5" H). Most American cars fit the radio from behind the dash and require a "bezel" that fits around the "Model Two" control face to fill the original factory opening.

The "Model Two" control face is NOT referred to as a "faceplate". A faceplate is a piece that overlays or covers the top or front of the dash. A faceplate is used in most European or Japanese cars, and can also be used on a modified dash to disguise any blemishes or poorly made modifications. Our flat Euro style faceplates are perfect for covering unsightly modifications. For unique installations, RetroSound offers a 3.5" H x 9"W universal plate that can be trimmed to get the desired appearance.

Once you've located the appropriate bezel or faceplate for your installation, perform the following steps to get the "Model Two" installed:

1. Use the supplied nuts and washers to align the faceplate onto the shaft. (NOTE: For illustration purposes, a faceplate is shown below in Figure 4. Bezels do not require this step.)
2. Once the shafts are lined up to the shaft openings on your vehicle-specific faceplate, use a nut and washer to hold the faceplate in place on the shafts. The "Model Two" face should be flush with the opening of the bezel or faceplate (see "Figure 4 - Install Vehicle Specific Faceplate").

- Use supplied nuts and washers to align the plate onto the shaft.
- Adjust nut height to allow the faceplate to align flush with your dash.

**NOTE: With the faceplate pictured below, the area around the radio face (chrome or black) mounts on top of the dash.**



Nuts/Washers Installed Between L Bracket and Faceplate

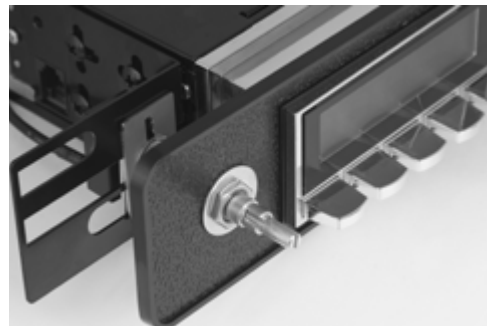

Figure 4 - Install Vehicle Specific Faceplate

## STEP 5: Install Knobs

Once your radio is installed, follow the steps below to ensure a proper knob fit.

1. The included shaft covers may be used to cover up excess shaft metal during your installation. They can be cut to any length to conceal the shaft and make the install look more professional. See Figure 5 for an example.
2. Slide the rear knob over the shaft, rotating it into the correct position, and push it into place. See Figure 6.
3. Mount the front-knob and you're done.



Figure 5 - Shaft Cover Installed



Figure 6 - Install Rear Knob



Figure 7 - Install Front Knob



Optional '67-68 Camaro Faceplate

Figure 8 - Final Result



## WIRING INSTRUCTIONS

PLEASE NOTE THAT THIS UNIT REQUIRES +12V TO BOTH THE RED AND YELLOW WIRES, OTHERWISE THE UNIT WILL NOT OPERATE. CONTACT US IF YOU HAVE QUESTIONS. (support@retrosoundusa.com) or 909-364-1371

### Wiring Diagram (Figure 9)

Before you begin, familiarize yourself with the "Model Two" wiring harness. Note that there are two plug connectors: plug "A", which contains power/ground connections and plug "B" which contains the speaker leads.

#### Installation Notes

- To prevent damage to the unit, do not connect the power connector until you have completed the wiring process.
- This is a 12 Volt negative-ground ONLY radio. If you have a positive ground, or a 6-volt system, you need to either convert to 12 volts or purchase a separate inverter that would step up the voltage to 12 volts.
- Please note that the inverter must be rated at 8 amps or higher in order for the radio to operate properly.

#### Rear AUX Inputs

Two rear auxiliary inputs allow you to listen to any portable device with standard headphone outputs. An example of an external source would be a portable CD player, mini disc player, portable cassette recorder, iPod® or MP3 player. Select an auxiliary input mode by turning the left rear knob clockwise until you see AUX IN 1 or AUX IN 2 on the "Model Two's" screen.

#### USB Connectivity

The USB connector is located at the rear of the "Model Two" radio. During installation, you must route the included 24 inch USB extension cable from the rear of the radio to a convenient and accessible location for plugging in a USB device. If the 24 inch cable is not long enough to suit your needs, you can substitute an optional extended length USB cable during installation.

**NOTE: Maximum operational distance of a USB cable is 16 feet. For optimum data transfer, we recommend no more than 12 feet of total cable length.**

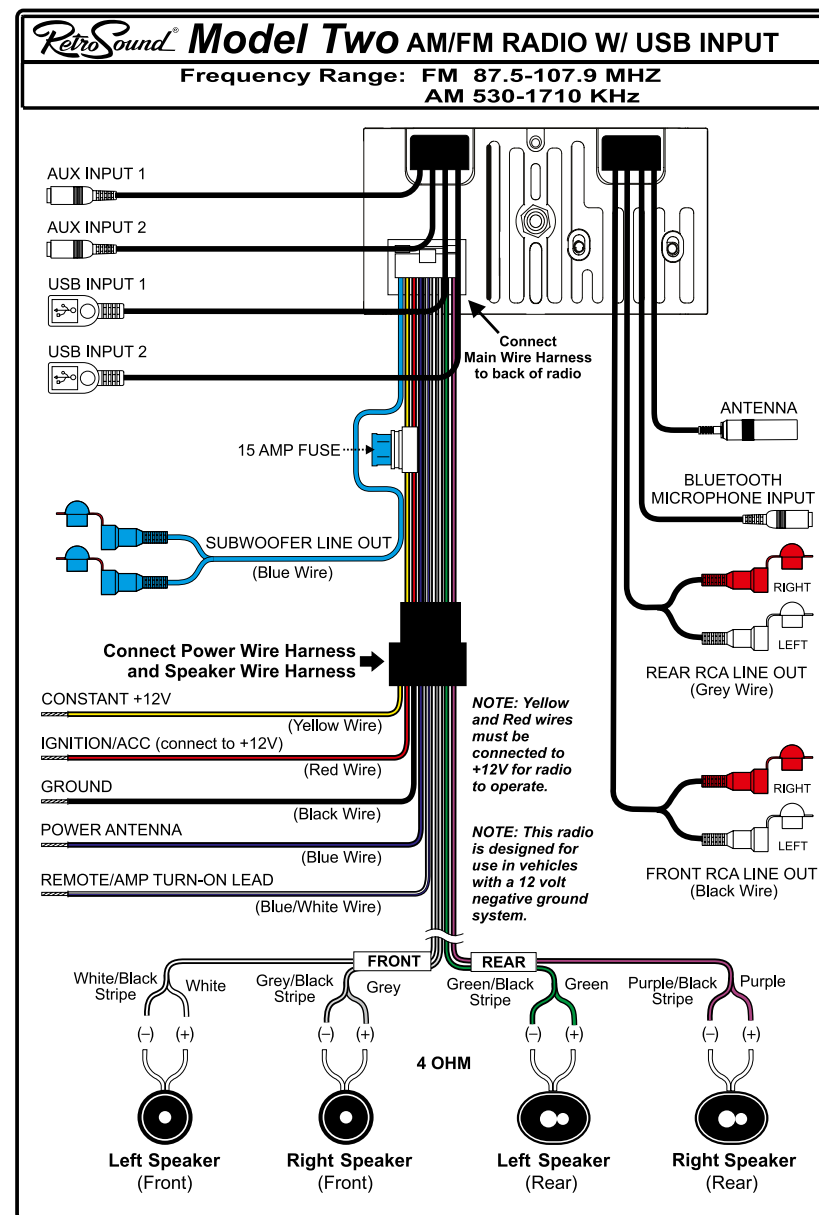

Figure 9 - Wiring Diagram

## USING YOUR RADIO (BASIC OPERATION)

### Front Panel Controls

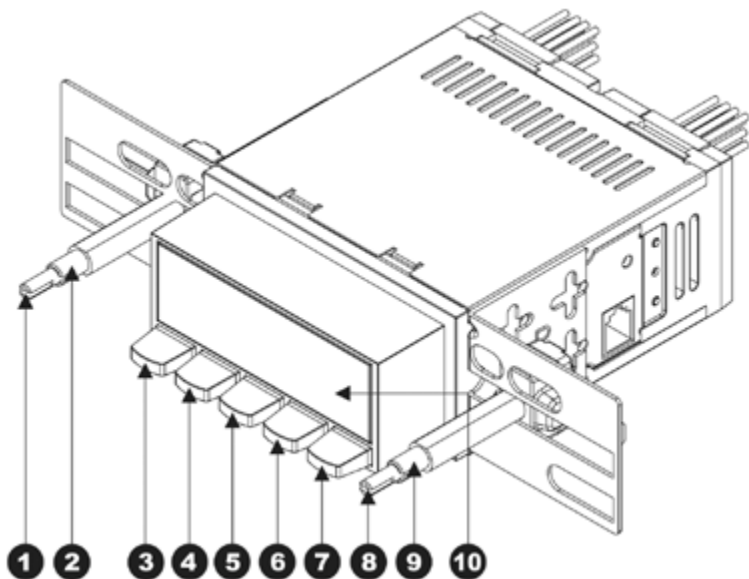

Figure 10 - Front Panel Controls

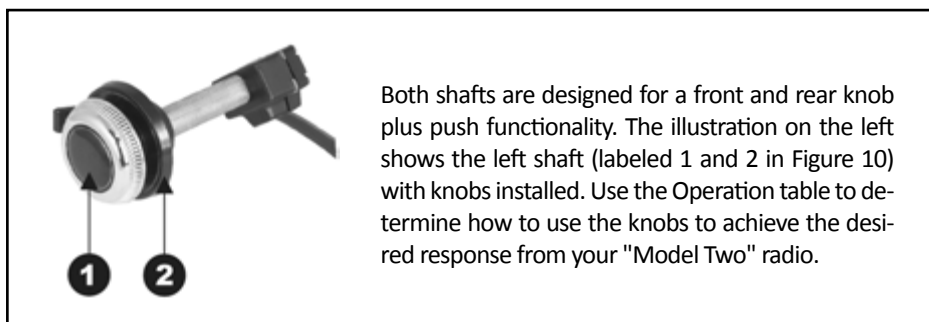

Figure 11 - Shaft with Knobs

### Operation Table

Function	#	Radio Mode	USB Mode
Power On/Off	1	Press the left knob to turn the unit on. Look for RETROSOUND on power up. Press and <b>hold</b> for 3 seconds to turn the unit off. The LCD display will show GOODBYE for your confirmation.	
Volume	1	Turn the left front knob to adjust the volume attenuation between 0 - 50 (Min/Max). 17 is the default turn-on volume level.	
Audio Adjust	1	Press the left knob to activate the SEL (Select) function. Press repeatedly to cycle through the DSP (Digital Signal Processing) EQ, Bass, Treble, Balance, Fader, LED White/Green and LCD High/Low functions. Turn the front center knob to select a value (See "Adjusting Sound Properties" on page 21 for detailed instructions).	
Mode	2	Turn the left rear knob clockwise to select from an available listening source: Radio, USB, AUX IN 1, AUX IN 2. Two sets of AUX inputs are located at the rear of the radio. To utilize these inputs, AUX cables must be routed to an accessible area during installation (See "Wiring Instructions" on page 15). <b>NOTE: The USB option will not appear unless media is plugged into the USB connector.</b>	
RDS TA	2	Turn the left rear knob clockwise and hold to activate the RDS TA Feature. TA or Traffic Announcement is a RDS function that allows FM stations to broadcast traffic announcements that scroll across the screen and will also broadcast audible traffic alerts to your radio.	
Clock On	2	Turn the left rear knob counter-clockwise to activate the clock on screen feature.	Turn the left rear knob counter to toggle and view artist, album, and title information.
View Song Info			

Function	#	Radio Mode	USB Mode
Preset 1 Recall/Store	3	Press to select the #1 radio preset.	Press to play/pause file playback.
Play/Pause		Press and <b>hold</b> to store preset 1 into memory.	
Preset 2 Recall/Store	4	Press to select the #2 radio preset.	Press to play 10 seconds of each track on the flash drive. Press again to cancel the preview scan function. The song name appears as it plays. INT ON appears on the screen during intro scan mode.
Preview Scan		Press and hold to store preset 2 into memory.	
Preset 3 Recall/Store	5	Press to select the #3 radio preset. Press and <b>hold</b> to store preset 3 into memory.	Press to randomly play all digital tracks on your flash drive, regardless of the folder selected. RDM ON appears on the screen during random mode.
Preset 4 Recall/Store	6	Press to select the #4 radio preset.	Press to move UP through folders on your drive. The first file in the selected folder will play. The screen will display DIR 001, DIR 002, etc.
Random		Press and hold to store preset 4 into memory.	
Preset 5 Recall/Store	7	Press to select the #5 radio preset.	Press to move DOWN through folders on your drive. The first file in the selected folder will play. The screen will display DIR 001, DIR 002, etc.
Select Folder		Press and hold to store preset 5 into memory.	

Function	#	Radio Mode	USB Mode
Next/Previous	8	Turn the right front knob to tune to the next or previous AM/FM frequency.	Turn the right front knob to change to the next/previous track. <b>This function also applies to Bluetooth Audio mode.</b>
System Menu		Press and <b>hold</b> the right front knob for 3 seconds to access the sub menu system where you can adjust: Auto/Manual tuning, RDS On/off, Clock or Frequency Priority, Loudness ON/OFF, Beep ON/OFF, AREA USA/EUR tuning, Stereo/Mono, Local/DX (distant) tuning, Vol Adjust/Vol Last and volume on default level. Toggle the selection by turning the front center knob and pressing the front center knob inward to go to the next mode (See "Special Modes (Sub-Menu System)" on page 24 for detailed instructions).	
Preset 6 Recall/Store	9	Turn the right rear knob clockwise to select the #6 radio preset.	Turn the right rear knob clockwise to repeat the current track (RPT ONE). Turn and hold to repeat all tracks (RPT ALL).
Repeat Play		Turn and <b>hold</b> the right rear knob clockwise to store preset 6 into memory.	
Band		Turn the right rear knob counter-clockwise to toggle through 5 radio bands (2 AM and 3 FM).	Turn the right rear knob counter-clockwise to activate the track or directory search function. Once in search mode, press the left front knob (8) to select track or search for directories, when the selection is found, press the left front knob to select a track number or directory.
Track/Directory Search			
Folder / Music Name		Turn the right rear knob counter-clockwise to view the folder or music name.	

Function	#	Radio Mode	USB Mode
iPod® / iPhone® Playlist / Search	9		While in USB-1 /USB-2 mode with an iPod® / iPhone® connected to one of the USB inputs, turn the right rear knob counter-clockwise to select the iPod Playlist. Turn the front right knob clockwise to choose from Playlist, Artist, Album, Genre, Songs, Composer, Audio Book or Podcast. Press the front right knob to access the selected mode, then turn clockwise to select items within the list. Press the front right knob again to listen to the selected item. To access this mode again, turn the right rear knob clockwise to select Repeat All or Repeat One.
RDS PTY		Turn and <i>hold</i> the right rear knob counter/clockwise, then release, to activate the RDS PTY (Program Type) feature. Use the preset buttons (labeled 3-7) to select program types. See "Program Type (PTY)" on page 29 for detailed instructions.	
LCD Display	10	Backlit LCD Display	

## ADJUSTING SOUND PROPERTIES

1. Press the left front knob, the release, to access the sound properties menu.
2. Repeatedly press and release the front left knob to scroll through the available menu options.
3. Turn the left front knob right or left to select a value for the chosen menu option.
4. Press and release the left front knob repeatedly to move to the next function desired, or do nothing and the menu will revert to the current source display.

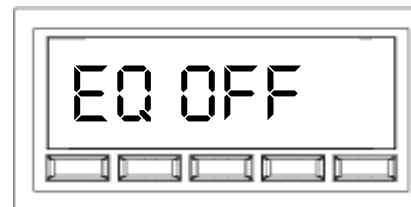

**EQ OFF**

When you first access the left front knob menu, EQ is set to OFF. Turn the left front knob right to view and select the 3 preset equalizer options.

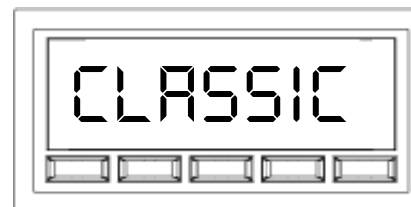

**CLASSIC**

The CLASSIC setting offers sonic adjustments that lend themselves to classical music.



**POP**

The POP setting accentuates the bass and treble settings. This is suitable for bass heavy popular music.

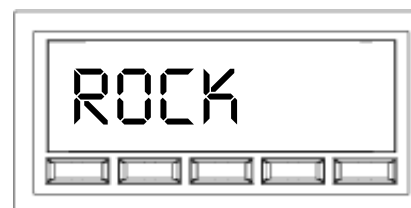

**ROCK**

The ROCK setting accentuates the treble settings. This is suitable for Rock Music.

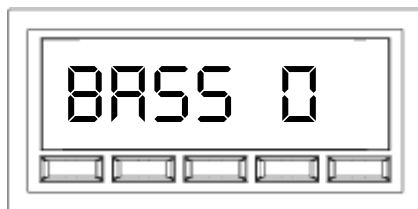
**BASS**

The bass adjustment function allows you to boost or cut the low frequencies from -7 to +7.

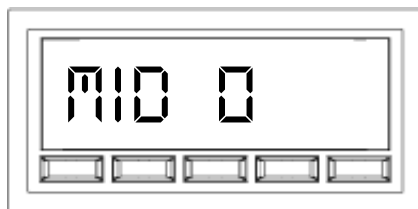
**MID**

The mid-range adjustment function allows you to adjust the middle frequencies -7 to +7.

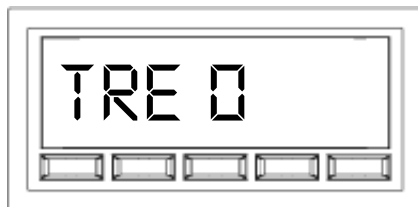
**TREBLE**

The treble adjustment function allows you to boost or cut the high frequencies from -7 to +7.

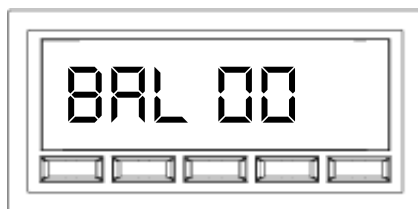
**BALANCE**

The balance adjustment function allows you to adjust or pan the stereo sound from the left or right. This is helpful to compensate for the position of the driver in relation to the speakers. Adjustment range is 0-12 between the left and right speakers.

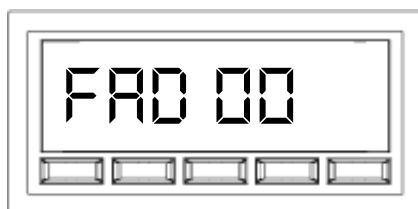
**FADER**

The fader control allows you to fade the sound from the front pair of speakers to the rear pair of speakers. Adjustment range 0-12 between front and rear speakers.

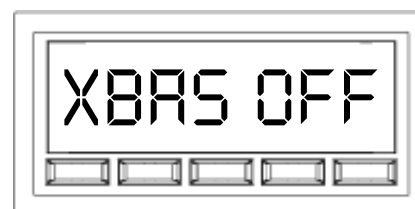
**XBAS**

This function boosts bass and treble at low listening volume and should be turned off at higher volumes. You will know this function is active when you see "XBAS" on your display. Adjusting your Bass, Mid or Treble settings will override the XBAS function.

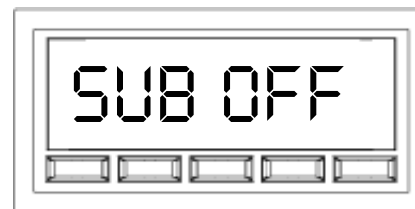
**SUB ON / OFF**

Turn the subwoofer RCA output ON to activate this features.

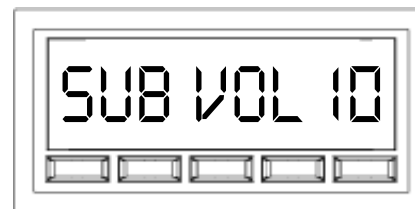
**SUB VOL**

When SUB ON is selected and a subwoofer is attached to the unit, use this function to increase or decrease the volume level of the subwoofer outputs from 0-12.

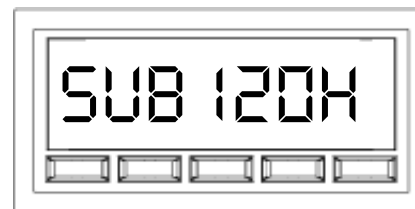
**SUB**

When SUB ON is selected and a subwoofer is attached to the unit, use this function to adjust the subwoofer crossover point to 80HZ, 12HZ or 160HZ.

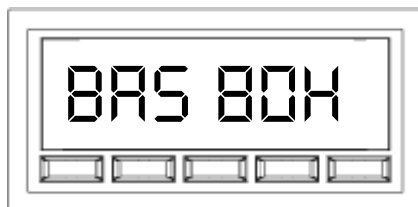
**BAS**

Use this function to make a more detailed boost or cut adjustment of bass (low) frequencies as follow: 60/80/100/200Hz. This is a very useful mode for making very specific tonal adjustment. When selecting one of these 60/80/100/200Hz points, any changes to the prior BAS menu settings on page 23 (-7 to +7) will boost or cut at the selected frequencies setting chosen in this menu.

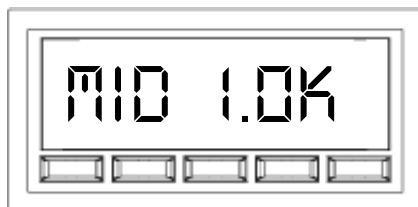
**MID**

Use this function to make a more detailed boost or cut adjustment of mid-range (vocal) frequencies as follows: 0.5K/1.0K/1.5K/2.5KHz. Default setting is 1.0KHz. This is a very useful mode for making very specific tonal adjustments. When selected one of these 0.5K/1.0K/1.5K/2.5KHz points, any changes to the prior MID menu settings on page 23 (-7 to +7) will boost or cut at the selected frequency setting chosen in this menu.

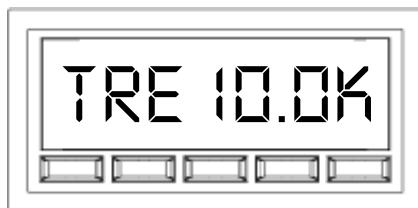
**TRE**

Use this function to make detailed boost or cut adjustment of treble frequencies as follows: 10.0K/12.5K/15.0K/17.5KHz. Default setting is 10.0KHz. When selecting one of these 10.0K/12.5K/15.0K/17.5KHz points, any changes to the prior TRE menu settings on page 23 (-7 to +7) will boost or cut at the selected frequency setting chosen in this menu. This is a very useful mode for making very specific tonal adjustments.

**SUB-MENU SYSTEM (RIGHT KNOB)****Accessing the System Menu**

1. Press and *hold* the right knob for 3 seconds, then release, to access the sub menu system.
2. Repeatedly press the center shaft to scroll through the available menu options.
3. Turn the right front knob right or left to select a value for the chosen menu option.
4. Press and release the right front knob to move to the next function desired, or do nothing and the menu will revert to the current source display.

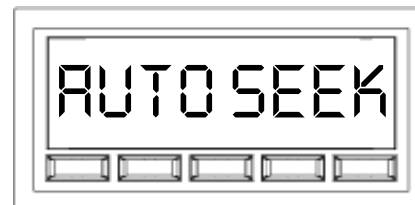
**Sub-Menu Options****AUTO SEEK**

This function allows you to select auto seek tuning or manual tuning when you turn the right front knob to the right or left when listening to the radio. The factory default setting is **AUTO SEEK**. Turn the right front knob clockwise or counter-clockwise to select manual or auto.

**A STORE**

This function will automatically fill presets with the strongest stations found for the current band. Turn the right front knob clockwise to activate this feature.

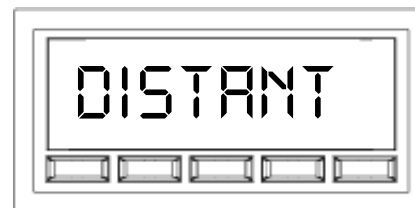
**LOCAL/DISTANT**

When listening to the FM tuner, you can access the LOCAL or DISTANT (default) option. Selecting between the local and distant settings can aid in listening to weak FM radio stations or compensate for stations that have too strong of a signal.

**CLOCK**

Choose the Clock function to adjust the clock hours and minutes. Adjusting past 12 will toggle the AM/ PM indication.

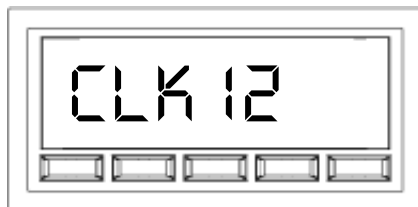
**CLK 12 / 24**

Adjust this function to choose between the 12 and 24 hour clock mode. The factory default setting is CLK 12.

**DISP FREQ / CLK**

The unit default setting displays frequency on the screen. Select DISP CLK show the clock as the priority screen view. Turn right front shaft clockwise or counter-clockwise to select DISP CLK or DISP FREQ. Push the front shaft knob to move to next menu item.

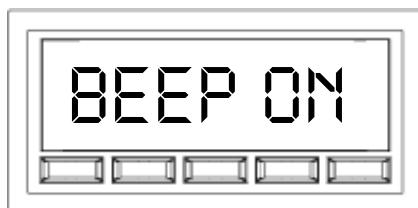
**BEEP ON/OFF**

This function controls the audible beep confirmation that sounds during radio operation. With the Beep function displayed, turn the right knob to select BEEP ON or BEEP OFF.

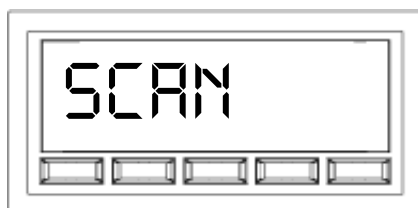
**SCAN**

Select the desired color preset. By default, the LCD lighting will alternate between all colors. Preset color options include WHITE, GREEN 1, PINK, PURPLE 1, PURPLE 2, BLUE 1, BLUE 2, USER and AMBER.

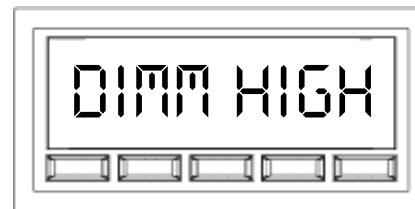
**DIMMER**

Use this menu option to switch the LCD brightness between high (DIMMER HIGH) and low (DIMMER LOW).

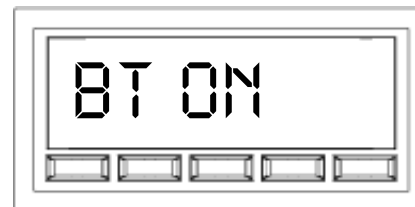
**Stereo/Mono**

Adjust this feature to turn the Bluetooth function ON/OFF.

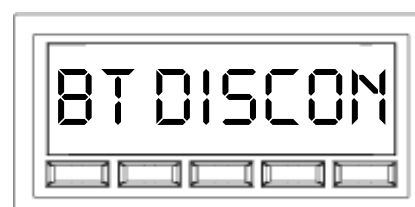
**BT DISCON/CONNEX**

Turn the right front shaft clockwise to select "CONNEX" to enable the bluetooth function and search for "RETROSOUND" in your phone's bluetooth device list. Enter password (0000) if prompted. Turn counter clockwise to select "DISCON" and disconnect a Bluetooth device.

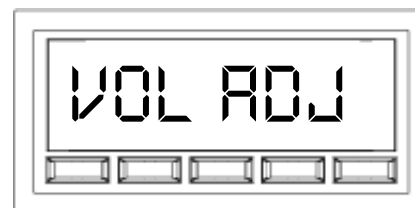
**RDS (ON/OFF)**

RDS stands for Radio Data System. This function allows you to turn off the RDS function if you desire to not see the RDS information. The factory default setting is RDS ON.

RDS tuners can automatically tune in stations according to the style of music (or talk) they broadcast. Some RDS tuners can even break in with traffic alerts or emergency broadcasts. RDS enables your receiver to display text messages (usually call letters and format info) that many FM stations include on a subcarrier signal within their normal broadcast signal. The RDS function is always active, and if the FM station you are listening to is broadcasting RDS information, the radio station call letters, song info, artist info and other messages will appear. Please note that not all FM stations use RDS. The standard has been around for over 15 years.

## Program Type (PTY)

RDS has a function called PTY (Program Type). This coding of up to 31 pre defined program types allow you to find similar programming by genre. When the tuner searches for this desired programming type, the tuner will study all strong FM stations to see what programming type they are broadcasting.

If the programming type is found, the radio will select it.

To use this function, turn and *hold* the right rear knob counter-clockwise to activate the RDS PTY (Program Type) feature. Use the preset buttons (labeled 3-7) to select program types to choose from 10 different program categories (2 per preset), then turn and hold the right rear knob another 2 seconds to access another bank of 10 program categories.

### Turn and *hold* once for these categories:

- 1# Preset: ROCK/CLS\_ROCK
- 2# Preset: SOFT\_RCK/TOP\_40
- 3# Preset: OLDIES/SOFT
- 4# Preset: NOSTALGIA/JAZZ
- 5# Preset: CLASSICL/R\_B
- 6# Preset: SOFT\_R\_B/REL\_MUSC (turn right rear knob)

### Turn and *hold* a second time for these categories:

- 1# Preset: NEWS/INFORM
- 2# Preset: SPORTS/TALK
- 3# Preset: ADLT\_HIT/COUNTRY
- 4# Preset: LANGUAGE/REL\_TALK
- 5# Preset: PERSNLTY/PUBLIC
- 6# Preset: COLLEGE/WEATHER (turn right rear knob)

Once the program type has been selected, the tuner will search all available FM stations for a station broadcasting the selected program category.

### EXAMPLE

If you're looking for country music stations, perform the following steps:

1. Turn and *hold* the right rear knob counter-clockwise to activate the RDS PTY (Program Type) feature.
2. Turn and *hold* the right rear knob another 2 seconds to access another bank of 10 program categories.
3. Press the third preset button to toggle between ADLT\_HIT and COUNTRY, choosing COUNTRY.

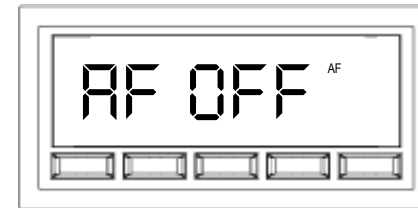

### AF ON/OFF (AREA EUR ONLY)

When in AREA EUR tuning mode, the "AF" RDS function (as a default) will be active, and the unit will search for the next strongest station when the one you're listening to gets weak (FM only). When AREA EUR is selected, this function appears on the sub-menu, allowing you to choose AF ON or AF OFF (default).

**IMPORTANT:** When switching the tuner to AREA EUR mode, your STORED radio presets will be erased and the clock will change to military/24 hour time.

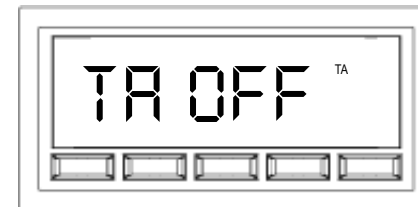

### TA(ON/OFF)

Adjust to turn the Traffic Announcement function on/off. TA allows FM stations to broadcast traffic announcements that scroll across the screen and will also broadcast audible traffic alerts to your radio.

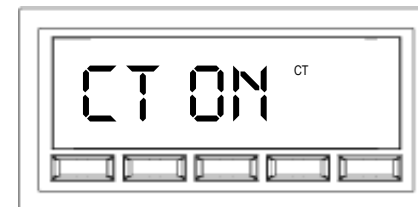

### CT(ON/OFF)

Adjust to turn the CT (Clock Time) function on/off. This feature can synchronize the clock, with accuracy within 100 ms of UTC.

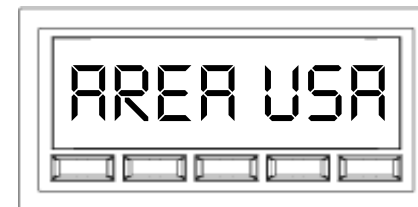

### AREA (USA/EUR/AUS/JAP/RUS)

The RetroSound Model Two radio has the capability to receive AM/ FM broadcast frequencies in other countries. To modify the default setting, AREA EUR (default), turn the right center shaft knob.

To confirm the change, let the sub menu revert to your tuner. You will see your selected mode: AREA USA, AREA EUR, AREA AUS, AREA JAP or AREA RUS.

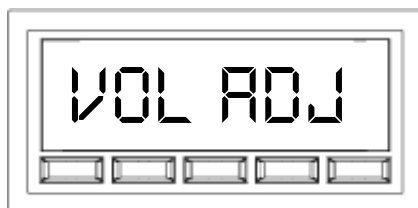

**VOL ADJUST/LAST**

Factory default for this menu options is **VOL LAST**, which maintains the last volume the radio was at when you turned it off. When you select **VOL ADJ**, you can set the default turn-on volume at any level (AD VAL 00-46), regardless of what the volume level was when you last turned off the unit.

**USB DEVICE INSTRUCTIONS****Attaching a USB Device**

The USB connector is located at the rear of the "Model Two" radio. During installation, you must route a USB extension cable from the rear of the radio to a convenient and accessible location for plugging in a USB device. See "Wiring Diagram (Figure 9)" on page 15 to locate the rear USB input.

Once you've turned on the "Model Two" and connected your flash drive to the USB input, the radio will find your songs instantly and automatically begin playing them from any mode.

The **USB** icon appears on the LCD during USB playback.

**NOTE: The USB input is for flash drive use ONLY. This unit will not control or charge an iPod®. Please use the rear auxiliary inputs to connect your iPod® or iPhone.**

To change songs, turn the right shaft knob to the right or left to access the next or previous song. Please note that the function buttons on the front of the faceplate will allow you to play/pause, listen to 10 seconds of each song (INT) or repeat the track you're listening to (RPT) or randomly select from all songs on the attached thumb/flash drive.

**NOTE: The unit MUST be in USB mode for it to read the USB files on your flash/thumb drive.**

**About MP3/WMA Files**

MP3 (MPEG Audio Layer-3) and WMA (Windows Media™ Audio) is a format for compressed audio files. When the "Model Two" radio is in USB mode, you can play MP3 and unprotected (no DRM) WMA files off the USB drive.

**Common facts about these compressed-sound formats:**

- High bit rate and high sampling frequencies are recommended for high sound quality.
- Selecting VBR (Variable Bit Rate) is not recommended because playing time is not displayed properly and there may be some audible skipping artifacts. The playback sound quality differs depending on the encoding circumstances. For details, refer to the user manual of your own encoding software.
- When adding MP3 files to your flash drive, it is recommended to set the bit rate to "128 kbps or more" and "fixed".

- When adding WMA files to you flash drive, it is recommended to set the bit rate to "64 kbps or more" and "fixed". Do not set the copy protect attribute on the WMA file or you will not be able to play the track.
- The "Model Two" will read only FAT or FAT32 formatted flash drives. This radio will NOT read NTFS formatted drives.
- The "Model Two" will read files placed in the root directory first before playing files in the folder structure of the drive. Please note that files are read in order of creation NOT alphabetically or numerically. Older files will get read first in a folder.

**Caution! Except for private use, duplicating audio data (including MP3/WMA) or distributing, transferring or copying it, whether for free or if it is paid for without permission of the original copyright holder is strictly prohibited by the Copyright Act and international treaty.**

## Viewing MP3/WMA Song Information

When playing MP3/WMA files from the USB source, the "Model Two" allows you to view the track name, album, artist info (ID-3) information automatically from these files. Once the USB Drive is inserted, the following info will scroll across the screen in the following order: F-DIR (Folder Directory), MP3 FILE (file name of song), ALBUM (Name of artist album) ARTIST (Name of artist), SONG (name of song).

**NOTE: To access the clock when in USB mode, turn the left rear knob counter-clockwise to activate the clock on screen feature. The clock will display until you turn the left rear knob counter-clockwise again.**

## USB Playback Mode

The function buttons on the front of the faceplate (1-5) will allow you to play/pause, listen to 10 seconds of each song (INT), repeat the track you're listening to (RPT), randomly select from all songs from a USB thumb/flash drive, and navigate folders (See "Operation Table" on page 18 for additional operating instructions for USB mode).

## BLUETOOTH INSTRUCTIONS

### Bluetooth Hands-Free and A2DP Streaming Operation

You can make or receive phone call using Bluetooth enabled phone connected to the "Model Two", controlling basic functions via the radio interface. During a call, the radio music source will be muted and call broadcast through your car speaker system. You can also listen to music stored on a A2DP enabled Bluetooth device.

### Pairing a Bluetooth Device

When connecting a Bluetooth device for the first time, you must first pair the device with the unit. For most devices, pairing only needs to be done once.

Please follow these steps:

1. Make sure the BT (Bluetooth) function is tuned "ON" in the radio Sub Menu. See "Sub-Menu System" on Page 24.
2. Change the "BT DISCON" function to "BT CONNECT".
3. Ensure Bluetooth is enabled on the phone to be connected to the unit.
4. Search for a new Bluetooth device from the phone (this may take up to 20 seconds).
5. Select "RETROSOUND" from the Bluetooth device list.
6. Some devices may require you to enter PIN. If prompted, enter "0000" for the PIN.
7. "PAIRING OK" will be displayed on the LCD display if pairing is successful. The paired device will then connect to the "Model Two" automatically.

**On some phones, you may need to select "SET AS AUTHORIZED" or similar to ensure the "Model Two" will automatically pair on subsequent usage.**

**PAIRED NOTIFICATION DISPLAY: When the Bluetooth device is paired with the "Model Two", the Bluetooth icon will appear on the LCD display. This should occur whenever you use the system while the paired device is in range.**

### Making a Call

1. Dial the desired number on the paired mobile phone.
2. Once dialing the progress, "CALLING" will be displayed on the LCD.
3. When the call is in progress, "TALK" will be displayed on the LCD, along with the elapsed call time (Talk 00:00)
4. The **Answer** button will also slowly flash to indicate you are in a call.

## Receiving a Call

1. If a call comes in, audio playback from the current source will either be muted or paused (depending on the source) and "PHONE IN" will be shown on the display, along with the Caller ID, if it is enabled by the phone/carrier.
2. Turn the left rear knob counter-clockwise to accept the call.
3. To reject the call, turn the left rear shaft knob counter-clockwise and it will not be answered.

## Ending a Call

Once in a call, Turn the left rear shaft knob counter-clockwise to end the call.

**NOTE: Regarding placement of the included Bluetooth microphone, we suggest mounting on the sun visor, A-pillar or steering column inside the vehicle, closest to the driver. The microphone is very sensitive and you may speak at a normal volume when using hands-free operation.**

## TROUBLESHOOTING

Problem	Mögliche Ursache	Lösungsansatz
Radio will not turn on (no Power on LED indicator)	12 Volt Batt+ wire not connected or incorrect voltage   remote wire not connected or incorrect voltage	Check all connections for proper voltage with a volt meter. Voltage range: 12-15 volts.
	Ground wire not connected	Check ground connection.
	Fuse on Batt+ is blown	Replace blown fuse.
No sound heard from unit but LED power indicator is on	Volume turned all the way down	Increase radio volume.
	Input signal not connected	Check low level inputs for proper connection.
Unit blows fuses	Incorrect fuse rating	Use fuses with correct 10 amp rating.
	Not +12 Volts / car battery not connected	Make sure the vehicle is + 12 volts and that the car battery is correctly connected to the vehicle.
USB ERR	Invalid media/device type	Please review the "USB Device Instructions" on page 33 to learn which formats and devices are acceptable for playback in this unit.

### System Reset

To restore/reset the unit to factory units, remove all power from the unit, wait 5 minutes and then reconnect power. The unit will revert to factory default settings.

## FREQUENTLY ASKED QUESTIONS

### ***Do your radios work on 6 Volt systems or on positive ground systems?***

No. Our radios are 12 Volt, negative ground only. After-market converters and inverters are available, but must have at least 8 amps of output.

### ***I have your radio and am having problems getting it to turn on.***

RetroSound radios require 12 Volts through both power leads. The red lead goes to a switched power source, and the Yellow to constant 12 Volt power source. Using a Volt Meter, check for voltage drop when the key is switched to "on." This means the circuit you are connected to cannot handle the additional draw of these modern electronics. Try moving the yellow power wire else where.

### ***What speaker wire do you recommend I use?***

We would recommend 16 or 18 gauge wire for the speakers. If it is a longer run, we recommend using 16 gauge only.

### ***I have a/14 speakers connected to your radio and the display is lit up like it is working, but there's no sound coming out.***

*This usually indicates one of two things:*

1. Speaker wires touching each other or the vehicle chassis at some point. Check each speaker lead from radio to speaker.
2. Speaker impedance below 4 Ohms. Older speakers are usually not compatible with modern electronics.

### ***My car originally came with a switch to control my automatic antenna. Can we use the RetroSound radio's remote antenna wire to do this?***

Your stock antenna is known as "semi-automatic." That is, you use a switch to either extend or retract the antenna. You must still use this switch to control your antenna the RetroSound radio's antenna wire is for more modern "fully automatic antennas" not requiring a separate switch.

### ***The sound output is a/1 mid-range, with very little bass and a strangled-sounding upper range. What is wrong?***

One of your speaker wires is connected backwards. This is called being "out of phase." Check to make sure positive is wired to positive and negative to negative on all your speakers.

### ***Will cutting or bending the Model One or Retro Classic's InfiniMount brackets void the warranty or harm the unit?***

No. RetroSound's Patented InfiniMount bracket system has been designed specifically to be bent, cut and modified to simplify radio installation. Indeed, cutting or modifying

the brackets- and not your dash!- is what RetroSound is all about. For questions about modifying the bracket system, please feel free to contact us at support@retrosoundusa.com or 909-364-1372. Keep in mind, no other radio made today is as flexible as ours. Modification to the radio is actually encouraged to ensure proper fit.

### ***I have your radio with an amp connected, but hear a whirring sound through the speakers when I step on the accelerator.***

If you have an external amplifier installed and experience a high-pitched noise that varies with the engine's RPM, there are many possible solutions:

1. Make sure the amplifier's gain controls are not turned all the way up. Amplifiers amplify everything, including noise.
2. Make sure to run the amplifier's low level input cables (RCA's) separately from the amplifier's power wire.
3. Try grounding the amplifier near where it is installed.
4. A low level (RCA) noise filter, known as a "ground loop isolator," is often effective at removing engine or alternator noise.
5. As a last resort, you can try a filter on the amplifier's 12 Volt power lead. Make sure to use a filter that includes a ground wire.
6. On rare occasions, noise can be introduced through the antenna lead. If disconnecting the antenna makes the noise go away, you need to replace or repair the antenna plug where it goes into the radio.

### ***When I plug in my flash drive, the screen says "Error" and it won't play the files I placed on the drive.***

1. Make sure the files on the drive are .mp3 or unprotected .wma (Windows Media Audio) files. iTunes files are .m4a format and need to be converted to .mp3 format, which can easily be done using iTunes.
2. Check if the flash drive is under 512k in size. The Model Two will play 1gig up to 32 gig size flash drives.
3. We've seen the "Error" occur when the flash drive is NTFS formatted. Try to use the FAT32 format (most drives are formatted with FAT32 from the factory). Please be sure to do a full format rather than a quick erase, and make sure none of the files or folders have names longer than 64 characters.

**SPECIFICATIONS**

**FM**

Tuning Range (EU and US Tuning Capable) with RDS ..... 87.5-107.9MHz  
 Antenna Terminal ..... External Antenna Connector  
 Usable Sensitivity ..... 12.5 dBf  
 Selectivity ..... 75 dB @ 400kHz  
 Signal to Noise Ratio ..... 62 dB (Stereo), 67 dB (Mono)  
 Harmonic Distortion @ 1 kHz ..... 0.8% (stereo), 0.5% (monaural)  
 Separation ..... 32 dB @ 1kHz  
 Frequency Response ..... 30-16,000 Hz

**AM (EU and US Tuning Capable)**

Tuning Range ..... 530-1710 kHz  
 Antenna Terminal ..... External Antenna Connector

**General**

Dimensions (Radio Face Only) ..... 3.5"W x 1.5" H x 1.05" D  
 Dimensions (Radio Body) ..... 3.96"W x 1.98"H x 4.30"D  
 Power Requirements ..... 10.5-14.4V  
 Current Consumption ..... Max. 15A  
 Current Consumption ..... <3.5 mA  
 Output Power (@ 12V @ 4 ohm @ 1% THD) ..... 25x4w RMS 45x4 Max Power  
 Output Impedance ..... 4-8ohm  
 Low Level Output (4 Channels) ..... 2.85V  
 AUX 1 Input (Rear) ..... >300 mV / 6 kΩ  
 AUX 2 Input (Front) ..... >300 mV / 6 kΩ  
 USB 1 Input ..... 5V (USB Female input)  
 USB 2 Input ..... 5V (USB Female input)

**NOTE: All Specifications are subject to change without notice.**

**Notes**

---

---

---

---

---

---

---

---

---

---

---

---

---

---

---

---

---

---

---

---

---

---

---

---

---

---

---

---

---

---

---

---

---

---

---

---

---

---

---

---

---

---

---

---

---

*RetroSound*<sup>®</sup>

Langwadener Straße 60  
D-41516 Grevenbroich  
Mail: [info@ampire.de](mailto:info@ampire.de)

Support:  
Phone.: +49-2181-81955-0  
Mail: [support@ampire.de](mailto:support@ampire.de)

**[www.ampire.de](http://www.ampire.de)**