

Panasonic

Installation Guide

Network Camera

Model No. **WV-SC385, WV-SC384**
WV-SC385E, WV-SC384E

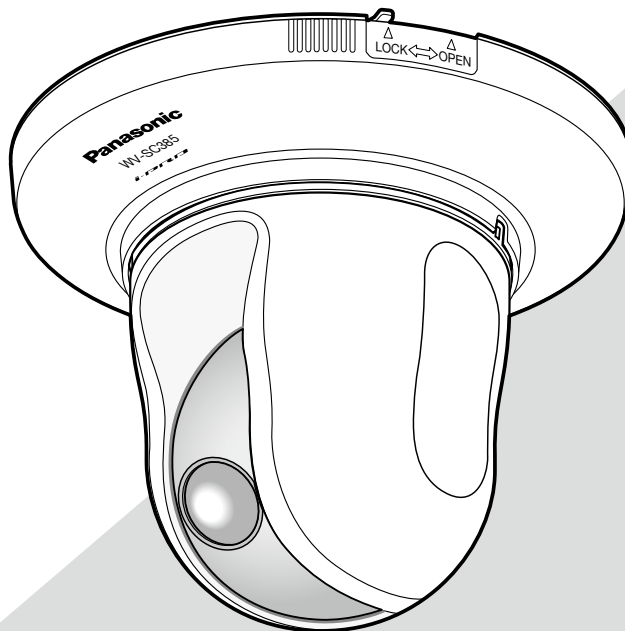

(This illustration represents WV-SC385.)



Before attempting to connect or operate this product,
please read these instructions carefully and save this manual for future use.

The model number is abbreviated in some descriptions in this manual.

We declare under our sole responsibility that the product to which this declaration relates is in conformity with the standards or other normative documents following the provisions of Directives 2006/95/EC and 2004/108/EC.

Wir erklären in alleiniger Verantwortung, daß das Produkt, auf das sich diese Erklärung bezieht, mit den folgenden Normen oder normativen Dokumenten übereinstimmt. Gemäß den Bestimmungen der Richtlinie 2006/95/EC und 2004/108/EC.

Nous déclarons sous notre propre responsabilité que le produit auquel se réfère la présente déclaration est conforme aux normes spécifiées ou à tout autre document normatif conformément aux dispositions des directives 2006/95/CE et 2004/108/CE.

Nosotros declaramos bajo nuestra única responsabilidad que el producto a que hace referencia esta declaración está conforme con las normas u otros documentos normativos siguiendo las estipulaciones de las directivas 2006/95/CE y 2004/108/CE.

Noi dichiariamo sotto nostra esclusiva responsabilità che il prodotto a cui si riferisce la presente dichiarazione risulta conforme ai seguenti standard o altri documenti normativi conformi alle disposizioni delle direttive 2006/95/CE e 2004/108/CE.

WARNING:

- Apparatus shall be connected to a mains socket outlet with a protective earthing connection.
- The mains plug or an appliance coupler shall remain readily operable.
- To prevent fire or electric shock hazard, do not expose this apparatus to rain or moisture.
- The apparatus should not be exposed to dripping or splashing and that no objects filled with liquids, such as vases, should be placed on the apparatus.
- All work related to the installation of this product should be made by qualified service personnel or system installers.
- For PERMANENTLY CONNECTED APPARATUS provided neither with an all-pole MAINS SWITCH nor an all-all pole circuit breaker, the installation shall be carried out in accordance with all applicable installation rules.
- The connections should comply with local electrical code.

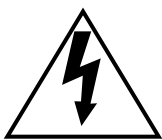
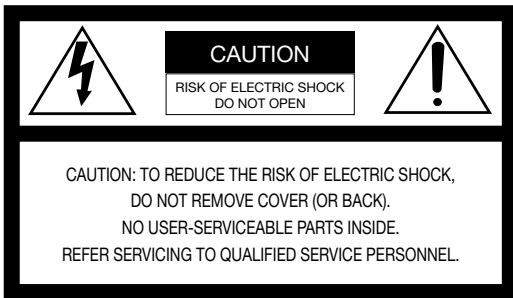

The lightning flash with arrowhead symbol, within an equilateral triangle, is intended to alert the user to the presence of uninsulated "dangerous voltage" within the product's enclosure that may be of sufficient magnitude to constitute a risk of electric shock to persons.



The exclamation point within an equilateral triangle is intended to alert the user to the presence of important operating and maintenance (servicing) instructions in the literature accompanying the appliance.

Power disconnection. Unit with or without ON-OFF switches have power supplied to the unit whenever the power cord is inserted into the power source; however, the unit is operational only when the ON-OFF switch is in the ON position. Unplug the power cord to disconnect the main power for all units.

Wij verklaren als enige aansprakelijke, dat het product waarop deze verklaring betrekking heeft, voldoet aan de volgende normen of andere normatieve documenten, overeenkomstig de bepalingen van Richtlijnen 2006/95/EC en 2004/108/EC.

Vi erklærer os eneansvarlige for, at dette produkt, som denne deklaration omhandler, er i overensstemmelse med standarder eller andre normative dokumenter i følge bestemmelserne i direktivene 2006/95/EC og 2004/108/EC.

Vi deklarerar härmed vårt fulla ansvar för att den produkt till vilken denna deklaration hänvisar är i överensstämmelse med de standarder eller andra normativa dokument som framställs i direktiv nr 2006/95/EC och 2004/108/EC.

Ilmoitamme yksinomaisella vastuullamme, että tuote, jota tämä ilmoitus koskee, noudattaa seuraavia standardeja tai muita ohjeellisia asiakirjoja, jotka noudattavat direktiivien 2006/95/EC ja 2004/108/EC säädöksiä.

Vi erklærer oss alene ansvarlige for at produktet som denne erklæringen gjelder for, er i overensstemmelse med følgende normer eller andre normgivende dokumenter som følger bestemmelsene i direktivene 2006/95/EC og 2004/108/EC.

This product contains CR Coin Cell Lithium Battery which contains Perchlorate Material - special handling may apply. See www.dtsc.ca.gov/hazardouswaste/perchlorate/

For U.S. and Canada:
WV-SC385, WV-SC384
For Europe and other countries:
WV-SC385E, WV-SC384E

UL listed model No.
WV-SC385, WV-SC384

For Canada
This Class A digital apparatus complies with Canadian ICES-003.

For U.S.A
NOTE: This equipment has been tested and found to comply with the limits for a Class A digital device, pursuant to Part 15 of the FCC Rules. These limits are designed to provide reasonable protection against harmful interference when the equipment is operated in a commercial environment. This equipment generates, uses, and can radiate radio frequency energy and, if not installed and used in accordance with the instruction manual, may cause harmful interference to radio communications. Operation of this equipment in a residential area is likely to cause harmful interference in which case the user will be required to correct the interference at his own expense.

FCC Caution: To assure continued compliance, (example - use only shielded interface cables when connecting to computer or peripheral devices). Any changes or modifications not expressly approved by the party responsible for compliance could void the user's authority to operate this equipment.

For U.S.A
The model number and serial number of this product may be found on the surface of the unit. You should note the model number and serial number of this unit in the space provided and retain this book as a permanent record of your purchase to aid identification in the event of theft.

Model No. _____
Serial No. _____

Contents

Important safety instructions.....	4
Limitation of liability.....	5
Disclaimer of warranty.....	5
Preface	6
Main functions.....	6
About the user manuals	7
About notations.....	7
System requirements for a PC	7
Trademarks and registered trademarks.....	8
About copyright and license.....	8
Network security	8
Precautions	9
Precautions for installation.....	12
Major operating controls	13
Installations/Connections.....	15
Detach the camera	25
Insert/remove an SDHC/SD memory card	26
Configure the network settings	28
Troubleshooting.....	30
Specifications.....	34
Standard accessories.....	37
Optional accessories.....	37

Important safety instructions

- 1) Read these instructions.
- 2) Keep these instructions.
- 3) Heed all warnings.
- 4) Follow all instructions.
- 5) Do not use this apparatus near water.
- 6) Clean only with dry cloth.
- 7) Do not block any ventilation openings. Install in accordance with the manufacturer's instructions.
- 8) Do not install near any heat sources such as radiators, heat registers, stoves, or other apparatus (including amplifiers) that produce heat.
- 9) Do not defeat the safety purpose of the polarized or grounding-type plug. A polarized plug has two blades with one wider than the other. A grounding type plug has two blades and a third grounding prong. The wide blade or the third prong are provided for your safety. If the provided plug does not fit into your outlet, consult an electrician for replacement of the obsolete outlet.
- 10) Protect the power cord from being walked on or pinched particularly at plugs, convenience receptacles, and the point where they exit from the apparatus.
- 11) Only use attachments/accessories specified by the manufacturer.
- 12) Use only with the cart, stand, tripod, bracket, or table specified by the manufacturer, or sold with the apparatus. When a cart is used, use caution when moving the cart/apparatus combination to avoid injury from tip-over.



- 13) Unplug this apparatus during lightning storms or when unused for long periods of time.
- 14) Refer all servicing to qualified service personnel. Servicing is required when the apparatus has been damaged in any way, such as power-supply cord or plug is damaged, liquid has been spilled or objects have fallen into the apparatus, the apparatus has been exposed to rain or moisture, does not operate normally, or has been dropped.

Limitation of liability

THIS PUBLICATION IS PROVIDED "AS IS" WITHOUT WARRANTY OF ANY KIND, EITHER EXPRESS OR IMPLIED, INCLUDING BUT NOT LIMITED TO, THE IMPLIED WARRANTIES OF MERCHANTABILITY, FITNESS FOR ANY PARTICULAR PURPOSE, OR NON-INFRINGEMENT OF THE THIRD PARTY'S RIGHT.

THIS PUBLICATION COULD INCLUDE TECHNICAL INACCURACIES OR TYPOGRAPHICAL ERRORS. CHANGES ARE ADDED TO THE INFORMATION HEREIN, AT ANY TIME, FOR THE IMPROVEMENTS OF THIS PUBLICATION AND/OR THE CORRESPONDING PRODUCT (S).

Disclaimer of warranty

IN NO EVENT SHALL Panasonic System Networks Co., Ltd. BE LIABLE TO ANY PARTY OR ANY PERSON, EXCEPT FOR REPLACEMENT OR REASONABLE MAINTENANCE OF THE PRODUCT, FOR THE CASES, INCLUDING BUT NOT LIMITED TO BELOW:

- (1) ANY DAMAGE AND LOSS, INCLUDING WITHOUT LIMITATION, DIRECT OR INDIRECT, SPECIAL, CONSEQUENTIAL OR EXEMPLARY, ARISING OUT OF OR RELATING TO THE PRODUCT;
- (2) PERSONAL INJURY OR ANY DAMAGE CAUSED BY INAPPROPRIATE USE OR NEGLIGENT OPERATION OF THE USER;
- (3) UNAUTHORIZED DISASSEMBLE, REPAIR OR MODIFICATION OF THE PRODUCT BY THE USER;
- (4) INCONVENIENCE OR ANY LOSS ARISING WHEN IMAGES ARE NOT DISPLAYED, DUE TO ANY REASON OR CAUSE INCLUDING ANY FAILURE OR PROBLEM OF THE PRODUCT;
- (5) ANY PROBLEM, CONSEQUENTIAL INCONVENIENCE, OR LOSS OR DAMAGE, ARISING OUT OF THE SYSTEM COMBINED BY THE DEVICES OF THIRD PARTY;
- (6) ANY CLAIM OR ACTION FOR DAMAGES, BROUGHT BY ANY PERSON OR ORGANIZATION BEING A PHOTOGENIC SUBJECT, DUE TO VIOLATION OF PRIVACY WITH THE RESULT OF THAT SURVEILLANCE-CAMERA'S PICTURE, INCLUDING SAVED DATA, FOR SOME REASON, BECOMES PUBLIC OR IS USED FOR ANY PURPOSE;
- (7) LOSS OF REGISTERED DATA CAUSED BY ANY FAILURE.

Preface

The network cameras WV-SC385/WV-SC384 are designed to operate using a PC on a network (10BASE-T/100BASE-TX). By connecting to a network (LAN) or the Internet, images and audio from the camera can be monitored on a PC via a network.

Note:

- It is necessary to configure the network settings of the PC and its network environment to monitor images and audio from the camera on the PC. It is also necessary to install a web browser on the PC.
-

Main functions

H.264/MPEG-4 and JPEG triple encoding

H.264/MPEG-4 stream and JPEG (MJPEG) outputs can be simultaneously provided.

* Either H.264 or MPEG-4 is selectable.

MEGA Super Dynamic **SC385**

( Operating Instructions (PDF))

MEGA Super Dynamic compensates brightness on a pixel-to-pixel basis so that it produces clearer images even if objects have various illumination intensities.

Wide dynamic range function equipped **SC384**

This function compensates brightness so that it produces clearer images even if objects have various illumination intensities.

Important:

- When the wide dynamic range function is activated, noise may be increased in the dark area of the object.
-

Black & white function **SC385**

Images will be displayed clear even at night since the camera will be automatically switched from the color mode to the black and white mode under low illumination condition.

Megapixel-compatible lens and high accuracy preset position function

A single camera provides wide area monitoring.

The camera can be installed not only on the ceiling but also on the desktop **SC385**

When using an optional mount bracket, embedded installation on a ceiling or mounting on a wall is available.

Power over Ethernet function

When connecting with a PoE (Power over Ethernet) device, power will be supplied by simply connecting a LAN cable. (IEEE802.3af compliant)

Interactive communication with audio

By using the audio output connector and the microphone in connector, receiving audio from the cameras on a PC and transmitting audio from the PC to the cameras is available.

SDHC/SD memory card slot equipped

It is possible to save H.264 videos and JPEG images on the SDHC/SD memory card manually at an alarm occurrence, during the period of the schedule, or on a web browser. It is also possible to save JPEG images at a network failure occurrence. (Download is possible.)

* Recommended SDHC/SD memory card ( page 36)

About the user manuals

There are 2 sets of operating instructions for the WV-SC385, WV-SC384 (NTSC model), WV-SC385E, WV-SC384E (PAL model) as follows.

- Installation Guide: Explains how to install and connect devices, as well as how to connect and configure the network.
- Operating Instructions (PDF): Explains how to perform the settings and how to operate this camera.

The Operating Instructions covers the models: WV-SW395, WV-SC385, WV-SC384, WV-SW395E, WV-SC385E, WV-SC384E.

Adobe® Reader® is required to read these operating instructions (PDF) on the provided CD-ROM.

When the Adobe® Reader® is not installed on the PC, download the latest Adobe® Reader® from the Adobe web site and install it.

"WV-SC385, WV-SC384" or "SC385, SC384" shown in the instructions and illustrations used in these operating instructions indicates the WV-SC385, WV-SC384, WV-SC385E, WV-SC384E.

The screens used in these operating instructions show the case of NTSC model.

About notations

The following notations are used when describing the functions limited for specified models.

The functions without the notations are supported by all models.

SC385 : The functions with this notation are available when using the model WV-SC385.

SC384 : The functions with this notation are available when using the model WV-SC384.

System requirements for a PC

CPU:	Intel® Core™ 2 Duo 2.4 GHz or faster recommended
Memory:	512 MB or more (A minimum of 1 GB memory is required when using Microsoft® Windows® 7 or Microsoft® Windows Vista®.)
Network interface:	10BASE-T/100BASE-TX 1 port
Audio interface:	Sound card (when using the audio function)
Monitor:	Image capture size: 1024 x 768 pixels or more Color: 24-bit True color or better
OS:	Microsoft® Windows® 7 Professional (64-bit) Microsoft® Windows® 7 Professional (32-bit) Microsoft® Windows Vista® Business SP1 (32-bit) Microsoft® Windows® XP Professional SP3
Web browser:	Windows® Internet Explorer® 8.0 (32-bit) (Microsoft® Windows® 7 Professional (32-bit/64-bit)) Windows® Internet Explorer® 7.0 Microsoft® Windows Vista® Business SP1 (32-bit) Microsoft® Internet Explorer® 6.0 SP3 (Microsoft® Windows® XP Professional SP3)
Others:	CD-ROM drive (It is necessary to read the operating instructions and use the software on the provided CD-ROM.) DirectX® 9.0c or later Adobe® Reader® (It is necessary to read the operating instructions on the provided CD-ROM.)

Important:

- When using a PC that does not meet the above requirements, displaying of images may become slower or the web browser may become inoperable.
 - Audio may not be heard if a sound card is not installed on a PC. Audio may be interrupted depending on the network environment.
 - Microsoft® Windows® XP Professional 64-bit Edition is not supported.
 - When using IPv6 for communication, use Microsoft® Windows® 7 or Microsoft® Windows Vista®.
-

Note:

- Refer to "Notes on Windows Vista® / Windows® 7" (PDF) on the provided CD-ROM for further information about system requirements for a PC and precautions when using Microsoft® Windows® 7 or Microsoft® Windows Vista®.
 - If using Microsoft® Windows® XP, screen tearing* may occur when the shooting scene drastically changes (for example, while shooting fast-moving subjects or while controlling panning/tilting) due to the GDI restrictions of the OS.
* A phenomenon in which portions of the screen are displayed out of alignment
-

Trademarks and registered trademarks

- Microsoft, Windows, Windows Vista, Internet Explorer, ActiveX and DirectX are either registered trademarks or trademarks of Microsoft Corporation in the United States and/or other countries.
- Microsoft product screen shot(s) reprinted with permission from Microsoft Corporation.
- Intel and Intel Core are trademarks or registered trademarks of Intel Corporation in the United States and other countries.
- Adobe, the Adobe logo and Reader are either registered trademarks or trademarks of Adobe Systems Incorporated in the United States and/or other countries.
- SDHC Logo is a trademark of SD-3C, LLC.
- All other trademarks identified herein are the property of their respective owners.

About copyright and license

Distributing, copying, disassembling, reverse compiling and reverse engineering of the software provided with this product are all expressly prohibited. In addition, exporting any software provided with this product violating export laws is prohibited.

Network security

As you will use this unit connected to a network, your attention is called to the following security risks.

- ① Leakage or theft of information through this unit
- ② Use of this unit for illegal operations by persons with malicious intent
- ③ Interference with or stoppage of this unit by persons with malicious intent

It is your responsibility to take precautions such as those described below to protect yourself against the above network security risks.

- Use this unit in a network secured by a firewall, etc.
- If this unit is connected to a network that includes PCs, make sure that the system is not infected by computer viruses or other malicious entities (using a regularly updated anti-virus program, anti-spyware program, etc.).
- Protect your network against unauthorized access by restricting users to those who log in with an authorized user name and password.
- Apply measures such as user authentication to protect your network against leakage or theft of information, including image data, authentication information (user names and passwords), alarm mail information, FTP server information and DDNS server information.
- After the unit is accessed by the administrator, make sure to close the browser.
- Change the administrator password periodically.
- Do not install the camera in locations where the camera or the cables can be destroyed or damaged by persons with malicious intent.

Precautions

Refer installation work to the dealer.

Installation work requires technique and experiences. Failure to observe this may cause fire, electric shock, injury, or damage to the product. Be sure to consult the dealer.

Stop the operation immediately when something is wrong with this product.

When smoke goes up from this product or the smell of smoke comes from this product, stop the operation immediately and contact your dealer. Turn the power off immediately and contact qualified service personnel for service.

Do not attempt to disassemble or modify this product.

Failure to observe this may cause fire or electric shock. Consult the dealer for the repair or inspections.

Do not insert any foreign objects.

This could permanently damage the product. Turn the power off immediately and contact qualified service personnel for service.

Select an installation area that can support the total weight.

Selecting an inappropriate installation surface may cause the product to fall down or topple over, resulting in injury. Installation work shall be started after sufficient reinforcement.

Periodic inspections shall be conducted.

Rust on the metal parts or screws may cause a fall of the product resulting in injury or accidents. Consult the dealer for the inspections.

Do not use this product in an inflammable atmosphere.

Failure to observe this may cause an explosion resulting in injury.

Avoid installing this bracket in the locations where salt damage occurs or corrosive gas is produced.

Otherwise, the mounting portions will deteriorate and accidents such as a fall of this product may occur.

The measures of protection against a fall of this product shall be taken.

Failure to observe this may cause a drop resulting in injury. Be sure to install the safety wire.

The exclusively designed mount bracket shall be used.

Failure to observe this may cause a drop resulting in injury or accidents. Use the exclusively designed mount bracket for installation.

The screws and bolts must be tightened to the specified torque.

Failure to observe this may cause a drop resulting in injury or accidents.

Do not install this product in locations subject to vibration.

Loosening of mounting screws or bolts may cause a fall of the product resulting in injury.

Do not strike or give a strong shock to this product.

Failure to observe this may cause fire or injury.

Turn the power off when do wiring of this product.

Failure to observe this may cause electric shock. In addition, short circuit or wrong wiring may cause fire.

Do not rub the edges of metal parts with your hand.

Failure to observe this may cause injury.

Do not touch the main unit while this product is panning/tilting.

Fingers may be caught up in the moving part, and that may result in injury.

Keep SDHC/SD memory cards (option) away from infants and children.

Otherwise, they may swallow the cards by mistake. In this case, consult a doctor immediately.

Do not use tripod screws when installing this product on the ceiling.

Failure to observe this may cause injury. Use the exclusively designed mount bracket for installation.

Do not touch this product, the power cable or the connected cables during thunder. (Including during installation work)

Failure to observe this may cause electric shock.

Turn the power off when cleaning this product.

Failure to observe this may cause injury.

[Precautions for use]

This product is designed to be used indoors. This product is not operable outdoors.

This product has no power switch.

When turning off the power, turn off a circuit breaker.

To keep on using with stable performance

Do not use this product in hot and humid conditions for a long time. Failure to observe this causes component degradation resulting in life shortening of this product. Do not expose this product to direct heat sources such as a heater.

Do not touch the transparent part (over the lens) with your bare hands.

The dirty part causes deterioration of picture quality.

Handle this product with care.

Do not drop this product, nor apply shock or vibration to the product. Failure to observe this may cause trouble.

About the PC monitor

When displaying the same image on the monitor for a long time, the monitor may be damaged.

It is recommended to use a screen-saver.

When an error is detected, this product will restart automatically.

This product will be inoperable for around 2 minutes after the restart just as when the power is turned on.

Product disposal/transfer

Images saved on the SDHC/SD memory card may lead to personal information leakage. When it is necessary to dispose or give this product to someone, even when for repair, make sure that there is no data on the hard disk drives.

Cleaning this product body

Be sure to turn off the power before cleaning. Failure to observe this may cause injury. Do not use strong abrasive detergent when cleaning this product. Otherwise, it may cause discoloration. When using a chemical cloth for cleaning, read the caution provided with the chemical cloth product.

Important:

- The camera position may be moved inadvertently while cleaning the camera body. Restart the camera or refresh the camera position (position refresh) to correct the camera position. Refer to the Operating Instructions (PDF) for further information.
-

Transmission interval

Image transmission interval may become slow depending on the network environment, PC performance, shooting subject, access number, etc.

About SDHC/SD memory card

- Before inserting the SDHC/SD memory card, turn off the power of this product first. Otherwise, it may cause malfunction or damage data recorded on the SDHC/SD memory card. Refer to page 26 for descriptions of how to insert/remove an SDHC/SD memory card.
- When using an SDHC/SD memory card, format it using this product. Recorded data on the SDHC/SD memory card will be deleted when formatted. If an unformatted SDHC/SD memory card or an SDHC/SD memory card formatted with other devices is used, this product may not work properly or performance deterioration may be caused. Refer to the Operating Instructions (PDF) for how to format a SDHC/SD memory card.
- When some SDHC/SD memory cards are used with this product, the product may not work properly or performance deterioration may be caused. Use the SDHC/SD memory cards recommended in page 36.

Code label

The code labels (accessory) are required at inquiry for trouble. Use caution not to lose these labels. It is recommended to paste one of the labels onto the CD-ROM case.

About the MOS image sensor

- When continuously shooting a bright light source such as a spotlight, the color filter of the MOS image sensor may have deteriorated and it may cause discoloration. Even when changing the fixed shooting direction after continuously shooting a spotlight for a certain period, the discoloration may remain.
- When shooting fast-moving subjects or performing panning/tilting operations, objects crossing the shooting area may look to be bending askew.

MPEG-4 Visual Patent Portfolio License

This product is licensed under the MPEG-4 Visual Patent Portfolio License for the personal and non-commercial use of a consumer for (i) encoding video in compliance with the MPEG-4 Visual Standard ("MPEG-4 Video") and/or (ii) decoding MPEG-4 Video that was encoded by a consumer engaged in a personal and non-commercial activity and/or was obtained from a video provider licensed by MPEG LA to provide MPEG-4 Video. No license is granted or shall be implied for any other use. Additional information including that relating to promotional, internal and commercial uses and licensing may be obtained from MPEG LA, LLC.

See <http://www.mpegla.com>.

AVC Patent Portfolio License

THIS PRODUCT IS LICENSED UNDER THE AVC PATENT PORTFOLIO LICENSE FOR THE PERSONAL USE OF A CONSUMER OR OTHER USES IN WHICH IT DOES NOT RECEIVE REMUNERATION TO (i) ENCODE VIDEO IN COMPLIANCE WITH THE AVC STANDARD ("AVC VIDEO") AND/OR (ii) DECODE AVC VIDEO THAT WAS ENCODED BY A CONSUMER ENGAGED IN A PERSONAL ACTIVITY AND/OR WAS OBTAINED FROM A VIDEO PROVIDER LICENSED TO PROVIDE AVC VIDEO. NO LICENSE IS GRANTED OR SHALL BE IMPLIED FOR ANY OTHER USE. ADDITIONAL INFORMATION MAY BE OBTAINED FROM MPEG LA, L.L.C. SEE [HTTP://WWW.MPEGLA.COM](http://www.mpegla.com)

Consumable parts

The following are consumables: Replace them in accordance with their lives. Their lives vary depending on use environment and conditions.

Lens unit, panning motor, tilting motor, flat cable for panning, flat cable for tilting: Approx. 3.7 million operations (Lifetime approx. 20000 hours is just an indication when using the camera at +35 °C {95 °F}.)

About the self-diagnosis function

When this product malfunctions due to exogenous noise, etc. for 30 seconds or more, the product will automatically reset and will return to normal state. When the product is reset, initialization will be carried out as when the power of the product is turned on. When the product repeatedly resets, exogenous noise level around the product may be high and that may cause malfunction. Contact your dealer for instructions.

Motor operating sound

The operating sound may be louder depending on the speed of panning/tilting operations. When you feel uneasy, the operating sound can be diminished by reducing the setting value of auto panning speed.

Lens and pan/tilt head

If a lens and pan/tilt head are not performed for a long period of time, the grease coating inside these parts may become sticky. That may obstruct the parts from moving. To prevent this, move the lens or pan/tilt head periodically. Or perform position refresh.

Position refresh

During the use for a long period of time, the preset positions may become inaccurate. When "Position refresh" is set for the created schedule, the camera position will be corrected periodically.

Refer to the Operating Instructions (PDF) for how to perform the settings.

Precautions for installation

Panasonic assumes no responsibility for injuries or property damage resulting from failures arising out of improper installation or operation inconsistent with this documentation.

Installing place

Contact your dealer for assistance if you are unsure of an appropriate place in your particular environment.

- Make sure that the installation area is strong enough to hold this product, such as a concrete ceiling.
- When the installation area is not strong enough, reinforce and strengthen it or use an optional mount bracket (WV-Q155S, WV-Q155C or WV-Q105).
- When the product is installed on a wall, use the wall mount bracket WV-Q154C or WV-Q154S (option).
- When using an outdoor housing to install the product on the ceiling, use the inner cover (provided with WV-Q157 or other optional mount brackets). That can avoid the shape of the camera from reflecting on images.
- The optional mount brackets for WV-NS202A (WV-Q150C, WV-Q150S, WV-Q151C, WV-Q151S, WV-Q152C, WV-Q152S) cannot be used with this product.

Do not place this product in the following places:

- Locations where it may get wet from rain or water splash
- Locations where a chemical agent is used such as a swimming pool
- Locations subject to humidity, dust, steam and oil smoke
- Locations in a specific environment where a solvent or a flammable atmosphere exists
- Locations where a radiation, an X-ray, a strong radio wave or a strong magnetic field is generated
- Locations where corrosive gas is produced, locations where it may be damaged by briny air such as sea-shores
- Locations where the temperature is not within $-10\text{ }^{\circ}\text{C}$ to $+50\text{ }^{\circ}\text{C}$ { $14\text{ }^{\circ}\text{F}$ to $122\text{ }^{\circ}\text{F}$ }.
- Locations subject to vibrations (This product is not designed for on-vehicle use.)
- Locations subject to condensation as the result of severe changes in temperature (In case of installing the camera in such locations, the dome cover may become foggy or condensation may be caused on the cover.)

Procure fixing screws separately.

The screws that secure this product are not supplied. Prepare them according to the material and strength of the area where the product is to be installed.

Screw tightening

- The screws and bolts must be tightened with an appropriate tightening torque according to the material and strength of the installation area.
- Do not use an impact driver. Use of an impact driver may damage the screws or cause tightening excessively.
- When a screw is tightened, make the screw at a right angle to the surface. After tightening the screws or bolts, perform visual check to ensure tightening is enough and there is no backlash.

Be sure to remove this product if it is not in use.

Radio disturbance

When this product is used near TV/radio antenna, strong electric field or magnetic field (near a motor, a transformer or a power line), images may be distorted and noise sound may be produced.

PoE (Power over Ethernet)

Use a PoE hub/device that is compliant with IEEE802.3af standard.

Router

When connecting this product to the Internet, use a broadband router with the port forwarding function (NAT, IP masquerade).

Refer to the Operating Instructions (PDF) for further information about the port forwarding function.

Time & date setting

It is necessary to set the time & date before putting this product into operation. Refer to the Operating Instructions (PDF) on the provided CD-ROM for descriptions of how to perform the settings.

Major operating controls

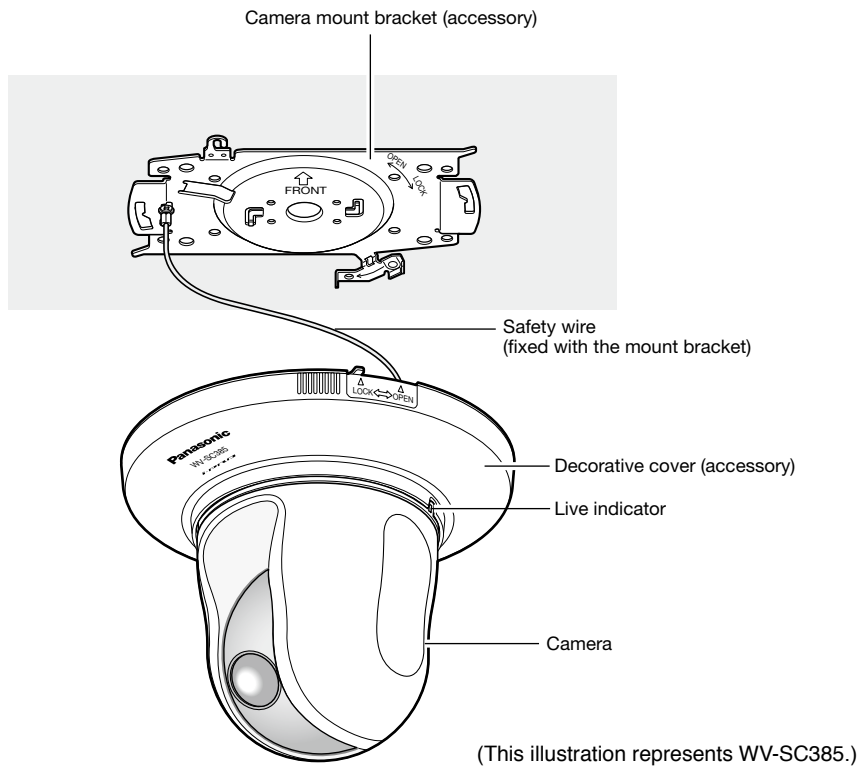

Front view

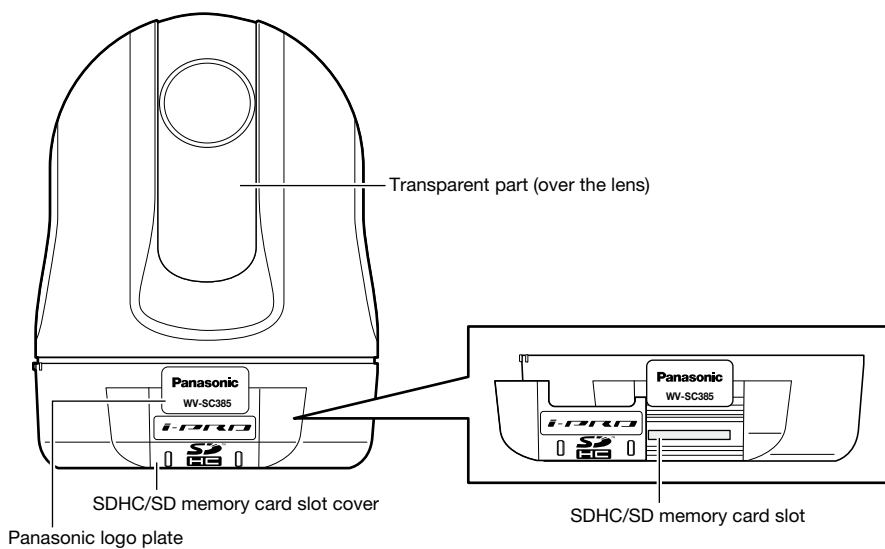

Rear view

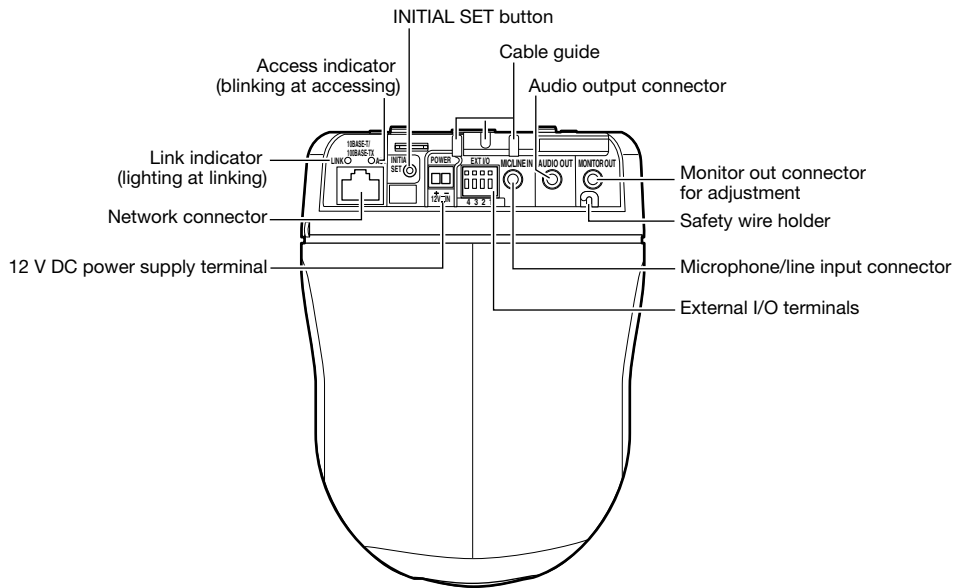

About the [INITIAL SET] button

After turning off the power of the camera, turn on the power of the camera while holding down this button, and wait for around 5 seconds or more without releasing this button. Wait around 3 minute after releasing the button. The camera will start up and the settings including the network settings will be initialized. Before initializing the settings, it is recommended to write down the settings in advance. The initialization will be complete when the live indicator stops blinking orange and lights off. Note that the preset position settings and the CRT key (SSL encryption key) used for the HTTPS protocol will not be initialized.

Important:

- Do not turn off the power of the camera during the process of initialization. Otherwise, it may fail to initialize and may cause malfunction.
-

Bottom view

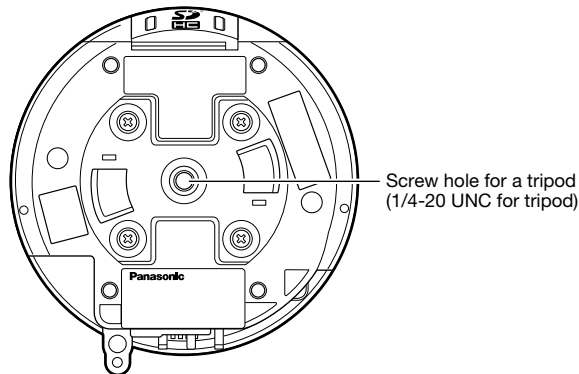

Important:

- Do not use this hole to mount on the ceiling since the fall prevention measure is unavailable.
-

Installations/Connections

Caution:

- FOR UL LISTED MODEL(S), ONLY CONNECT 12 V DC CLASS 2 POWER SUPPLY.

This camera is designed to be installed on a ceiling.

Before starting the installation/connection, prepare the required devices and cables.

Before starting the connection, turn off the power of the devices including the camera and the PC or disconnect from the 12 V DC power supply.

Install

When installing the camera on a ceiling, there are two methods; wiring through a hole in the ceiling (☞ page 16) and wiring through a cable guide (unnecessary to make a hole in the ceiling) (☞ page 20).

Important:

- Procure 4 screws (M4 or M6) to secure the camera mount bracket (accessory) to the ceiling according to the material of the installation area. In this case, wood screws and nails should not be used.
When installing on concrete ceiling: Fix with anchor bolts (M6).
(Recommended tightening torque: M4: 1.6 N·m {1.18 lbf·ft}, M6: 5.0 N·m {3.69 lbf·ft})
- Required pull-out capacity of a single screw/bolt is 196 N {19.99 lbf} or more.
- If a ceiling board such as plaster board is too weak to support the total weight, the area shall be sufficiently reinforced or the ceiling mount bracket for the camera WV-Q105 (option), or the ceiling embedding bracket WV-Q155S/ WV-Q155C (option), shall be used.
- When using an outdoor housing to install the product on the ceiling, use the inner cover (provided with WV-Q157 or other optional mount brackets). That can avoid the shape of the camera from reflecting on images.
- When using a mount bracket (option) or inner cover (provided with WV-Q157 or other optional mount brackets), refer to the operating instructions of the bracket in use.
- Remove the cover film from the transparent part of the dome cover after the installation is complete.
- Be sure to install the safety wire to prevent a fall of the camera resulting in injury or accidents in case the mount bracket (accessory) comes off. (Only for models that can be installed with a safety wire)

<When using the optional mount bracket WV-Q105>

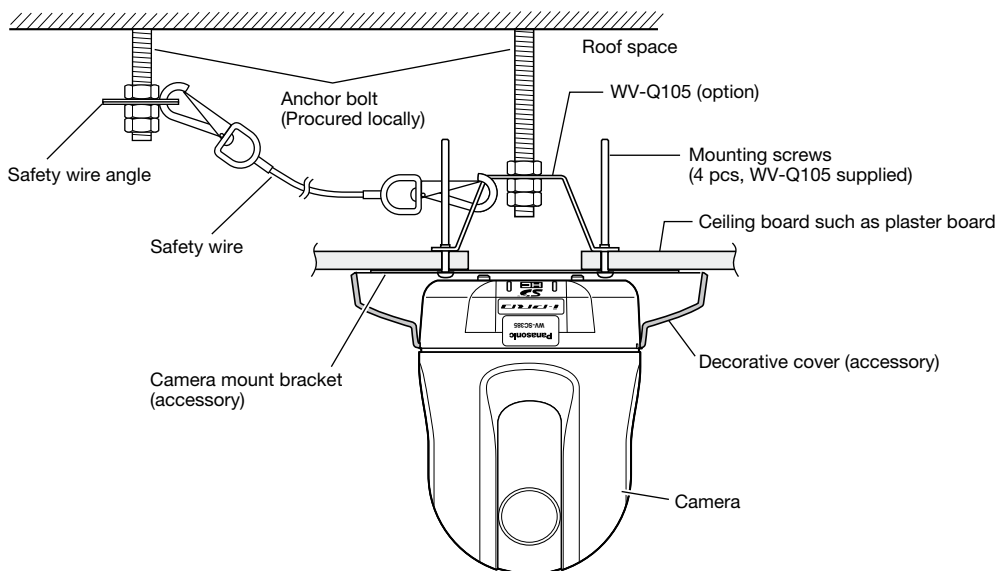

Wire through a hole in the ceiling

Step 1

Fix the camera mount bracket (accessory) with four optional fixing screws (M4 or M6, option). There should be no obstacles such as wall in a range of 100 mm {3-15/16 inches} away from the center point of the camera mount bracket.

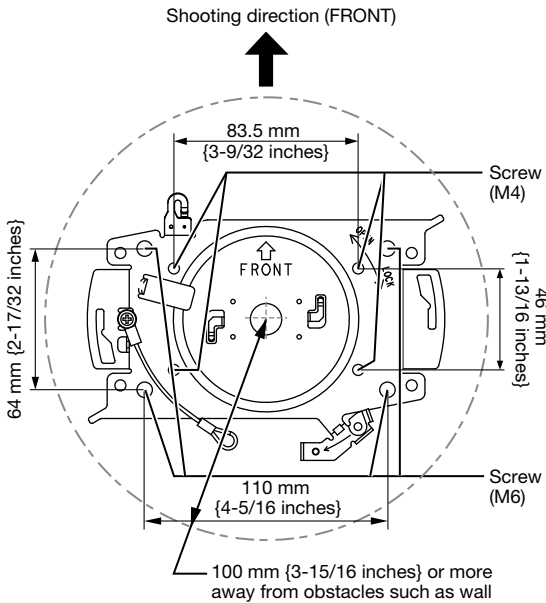

Step 2

Make a hole in the ceiling to pass the cables through. Make a hole 25 mm {31/32 inches} in diameter. The center point of the hole should be located approx. 75 mm {2-15/16 inches} away from the center point of the camera mount bracket.

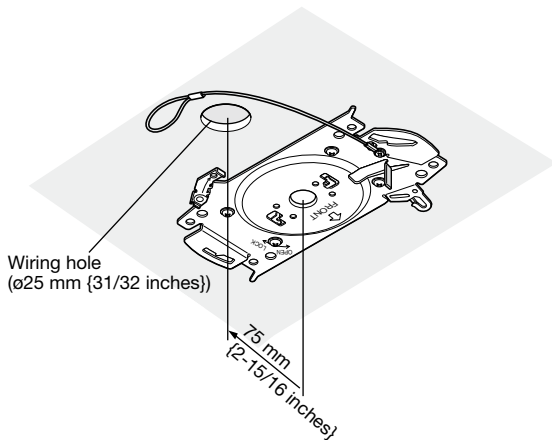

Step 3

Insert the SDHC/SD memory card into the SDHC/SD memory card slot. Refer to page 26 for how to insert the SDHC/SD memory card.

Step 4

Attach the safety wire fixed with the camera mount bracket (accessory) to the camera. After attaching the safety wire to the camera, confirm that the ring part at the end of the safety wire is securely hooked on the safety wire holder.

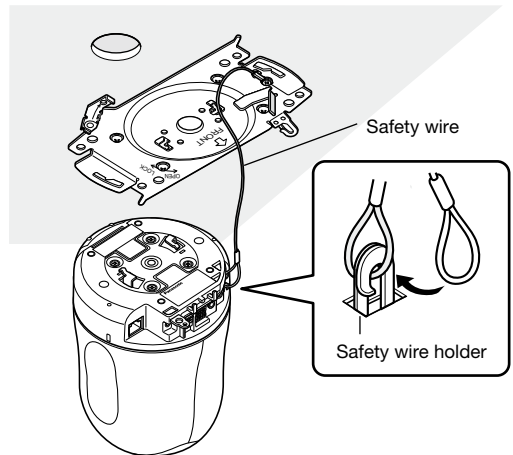

Step 5

Connect cables to the External I/O terminals, microphone/line input connector, audio output connector and the monitor out connector for adjustment. When connecting these cables, hold the base part of the camera.

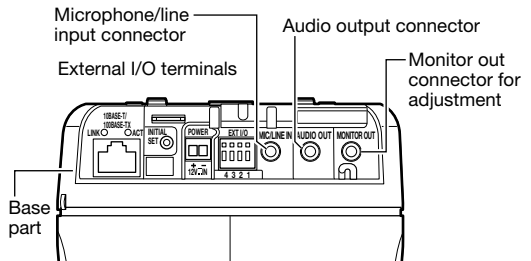

• External I/O terminals

Connect external devices. When connecting an external device, remove 9 mm - 10 mm {11/32 inches - 13/32 inches} of the outer jacket of the cable and twist the cable core to prevent the short circuit first.

Specification of cable (wire): AWG #22 - #28, Single core, twisted

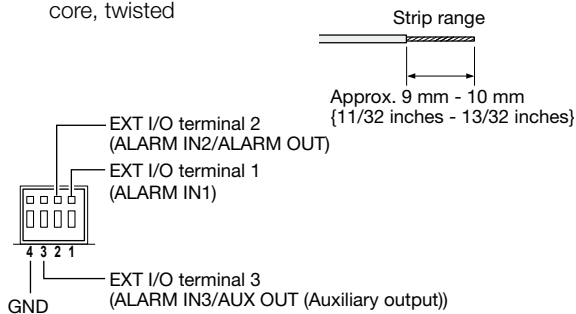

Important:

- Do not connect 2 wires or more directly to a terminal. When it is necessary to connect 2 or more wires, use a splitter.
- Input and output of the external I/O terminal 2 and 3 can be switched by configuring the setting. Refer to the Operating Instructions (PDF) for further information about the EXT I/O terminal 2 and 3 (ALARM IN2, 3) settings ("Off", "Alarm input", "Alarm output" or "AUX output").
- The default of EXT I/O terminals is "Off". When "Off" is selected, it is possible to connect external devices as well as the input setting.
- When using the EXT I/O terminals as the output terminals, ensure they do not cause signal collision with external signals.

<Ratings>

- ALARM IN1, ALARM IN2, ALARM IN3
Input specification: No-voltage make contact input (4 V - 5 V DC, internally pulled up)
OFF: Open or 4 V - 5 V DC
ON: Make contact with GND (required drive current: 1 mA or more)
- ALARM OUT, AUX OUT
Output specification: Open collector output (maximum applied voltage: 20 V DC)
Open: 4 V - 5 V DC by internal pull-up
Close: Output voltage 1 V DC or less (maximum drive current: 50 mA)

• Microphone/line input connector

Connect a monaural mini plug ($\varnothing 3.5$ mm).

- Input impedance: Approx. 2 k Ω
- Recommended cable length: 1 m {3.28 feet} or less (for microphone input)
10 m {32.8 feet} or less (for line input)
- Recommended microphone: Plug-in power type (option)
- Supply voltage: 2.5 V ± 0.5 V
- Recommended sensitivity of microphone: -48 dB ± 3 dB (0 dB=1 V/Pa, 1 kHz)
- Recommended plug: L type

Important:

- Connect/disconnect the audio cables and turn on the power of the camera after turning off the power of the audio output devices. Otherwise, loud noise may be heard from the speaker.

• Audio output connector

Connect a stereo mini plug ($\varnothing 3.5$ mm) (Audio output is monaural.). Use an external powered speaker.

- Recommended cable length: 10 m {32.8 feet} or less
- Recommended plug: L type (A straight type plug must be 40 mm {1-9/16 inches} or less.)

• Monitor out connector for adjustment

Connect a monaural mini plug ($\varnothing 3.5$ mm) (only for checking if images are displayed on the monitor).

- Recommended plug: Straight type (Because of the pin array difference, it is difficult to fit an L type plug into this connector.)

Important:

- The monitor out connector for adjustment is provided only for checking the adjustment of the angular field of view on the video monitor when installing the camera or when servicing. It is not provided for recording/monitoring use.
- Black bands may appear at the top and bottom or right and left of the screen. (That does not affect the adjustment because the angular field of view is not changed.)

Step 6

Mount the camera onto the camera mount bracket (accessory). Fit the lock plate of the camera onto the guide part of the camera mount bracket, and rotate the camera clockwise after inserting the camera while putting the center of the camera (screw hole for a tripod) onto the center of the camera mount bracket.

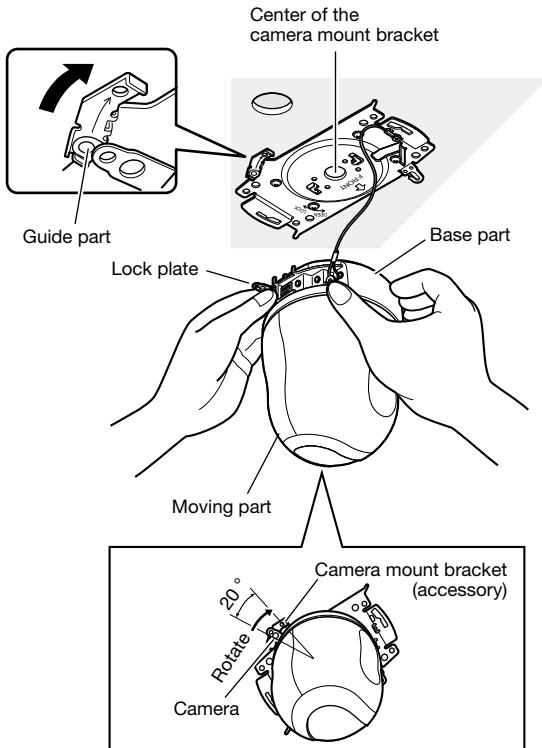

Important:

- When mounting the camera onto the camera mount bracket, hold the base part of the camera. Mounting the camera while holding the moving part may result in malfunction.

Step 7

Fix the camera on the camera mount bracket (accessory) using the camera fixing screw (accessory).

Recommended tightening torque: 0.68 N·m
{0.50 lbf·ft}

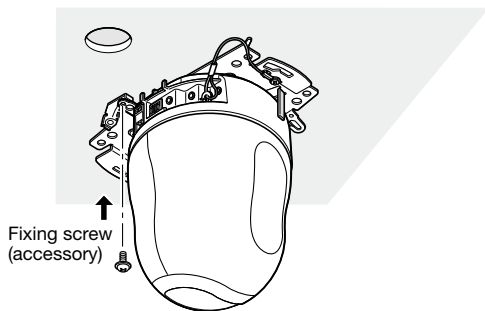

Step 8

Connect the cables to the network connector and the power inlet.

Important:

- When the power of the camera is turned on, the camera will start panning and the position will automatically be initialized.
 - Do not touch the camera in the process of initialization. Otherwise, it may fail to initialize and may cause malfunction.
 - When the camera has been inadvertently touched and moved after the initialization is complete, the preset positions may be inaccurate. In this case, use the position refresh function or restart the camera to correct the preset positions.
- Refer to the Operating Instructions (PDF) for further information.

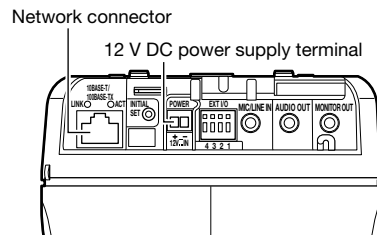

• **Network connector**

Connect a LAN cable (category 5 or better, STP*) to the network connector.

* PAL model only

Important:

- Use all 4 pairs (8 pins) of the LAN cable.
- The maximum cable length is 100 m {328 feet}.
- Make sure that the PoE device in use is compliant with IEEE802.3af standard.
- When connecting both the 12 V DC power supply and the PoE device for power supply, 12 V DC will be used for power supply.
- When the LAN cable is disconnected once, reconnect the cable after around 2 seconds. When the cable is quickly reconnected, the power may not be supplied from the PoE device.

• 12 V DC power supply terminal

- ① Loosen the screw of the power cable plug (accessory).
- ② Connect the output cable to the power cable plug. Strip 3 mm to 7 mm {1/8 inches to 9/32 inches} from the end of the wire, and twist the stripped part of the wire sufficiently to avoid short circuit.

Specification of cable (wire): 16 AWG - 24 AWG,
Single core, twisted

* Check whether the stripped part of the wire is not exposed and is securely connected.

- ③ Tighten the screw of the power cable plug.
- ④ Connect the power cable plug to the 12 V DC power supply terminal on the rear of the camera.

* FOR UL LISTED MODEL(S), ONLY CONNECT 12 V DC CLASS 2 POWER SUPPLY.

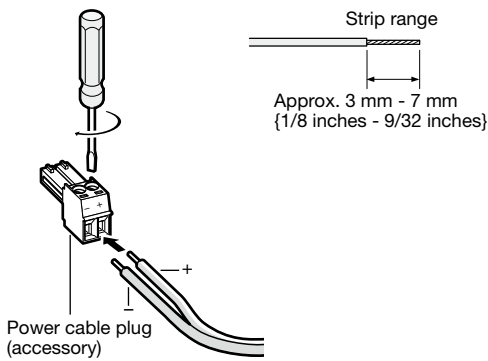

Important:

- Be sure to use the power cable plug provided with this product.
- Be sure to fully insert the power cable plug into the 12 V DC power supply terminal. Otherwise, it may damage the camera or cause malfunction.

Step 9

After completing the cable connections, attach the decorative cover (accessory).

- ① Align the indication "OPEN" of the decorative cover to the decorative cover guide of the camera mount bracket.

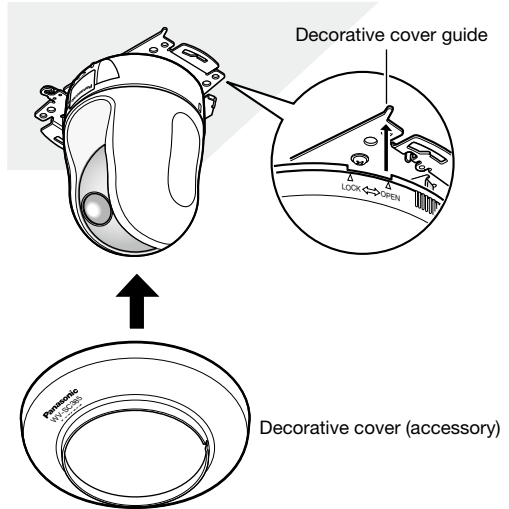

- ② Rotate the decorative cover clockwise into the mount bracket until the "LOCK" indications on both sides of the cover reaches the decorative cover guide of the mount bracket.

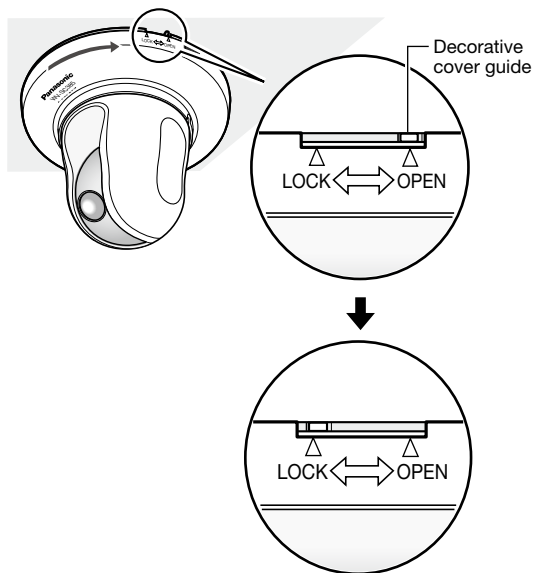

Important:

- Make sure that no cable is pinched by the decorative cover.

Wire without making a hole in the ceiling

Step 1

Install the camera by following step 1 and steps 3 - 8 of the "Wire through a hole in the ceiling" section (☞ pages 16 - 18). It is unnecessary to make a hole in the ceiling as described in step 2 of the "Wire through a hole in the ceiling" section.

Step 2

Remove the tab on the rear of the decorative cover (accessory) that is blocking the wiring hole.

Attach the decorative cover by following step 9 of the "Wire through a hole in the ceiling" section (☞ page 19).

Wire through the wiring hole of the decorative cover.

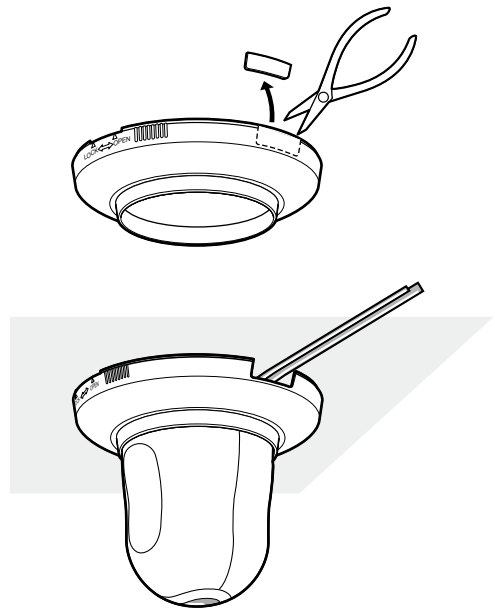

Place the camera upside-down by fixing on the bracket **SC385**

When using the camera upside-down, fix the camera using the camera mount bracket (accessory) to prevent a fall. If necessary, attach the decorative cover (accessory) to the camera.

Install the camera by following step 1 and steps 3 - 9 of the "Wire through a hole in the ceiling" section (☞ pages 16 - 19).

When using the camera upside-down, select "On (desktop)" for "Upside-down" on the [Cam. Function] tab of the setup menu. (☞ Operating Instructions (PDF))

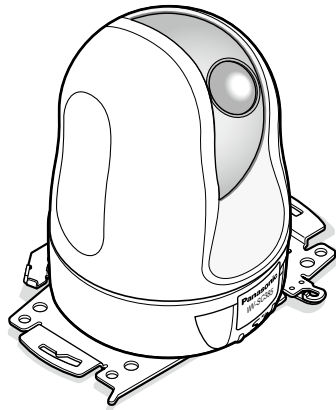

Important:

- Prepare four fixing screws (M4 or M6) to be used to mount the camera mount bracket (accessory) according to the material of the place where the camera mount bracket is to be installed.
-

Place the camera upside-down on a desktop without fixing **SC385**

Use it as a simple desktop device at meetings and on other occasions.

Place the camera on a level place not subject to vibrations.

Ensure that the camera does not fall.

When using the camera upside-down, select "On (desktop)" for "Upside-down" on the [Cam. Function] tab of the setup menu. (☞ Operating Instructions (PDF))

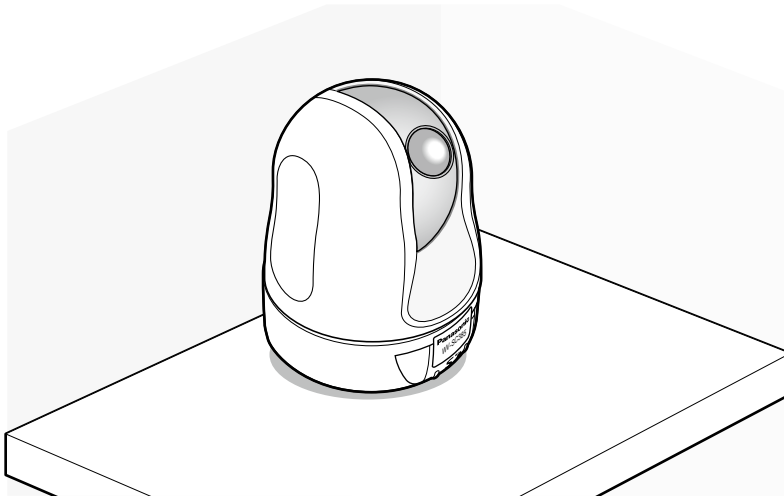

Pass the power cable from a 12 V DC power supply (accessory) through the cable guides after connecting the power cable plug to the 12 V DC power supply terminal.

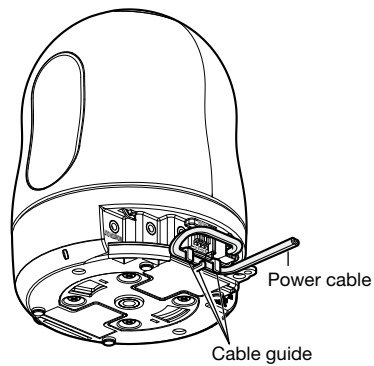

Installation examples

The following are installation examples in which a mount bracket (option) is used with this camera.

<For using the WV-Q154S>

• Embedded box (locally procured)

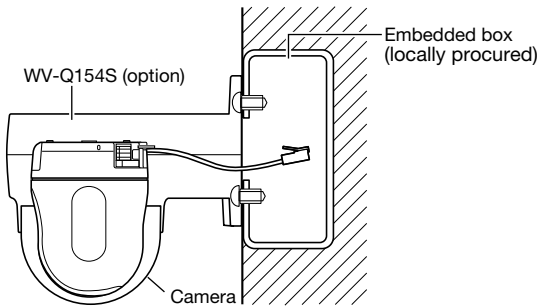

• Strong wall

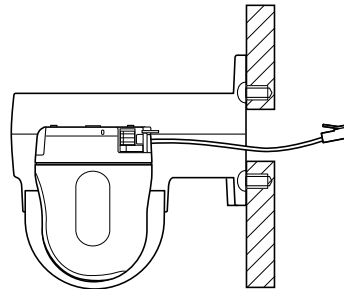

• Concrete

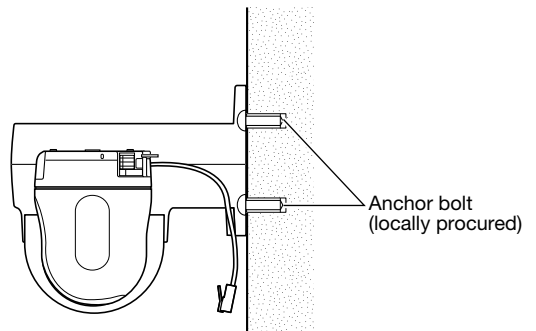
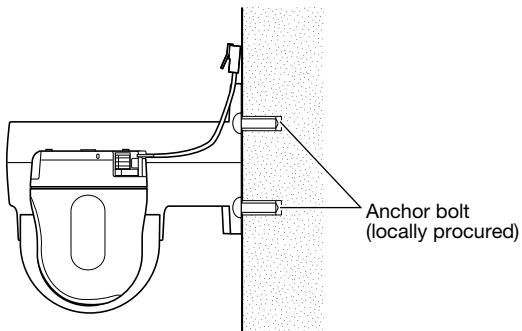

<For using the WV-Q155S>

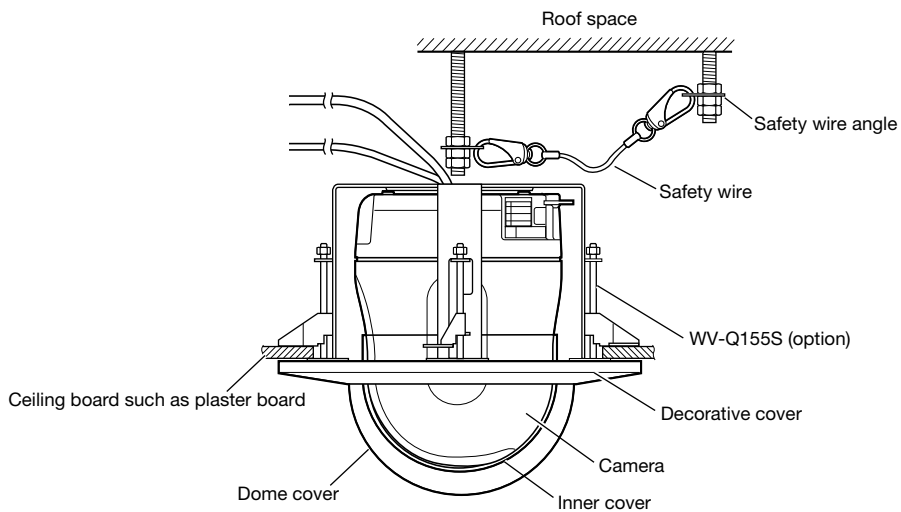

<For using the WV-Q156S>

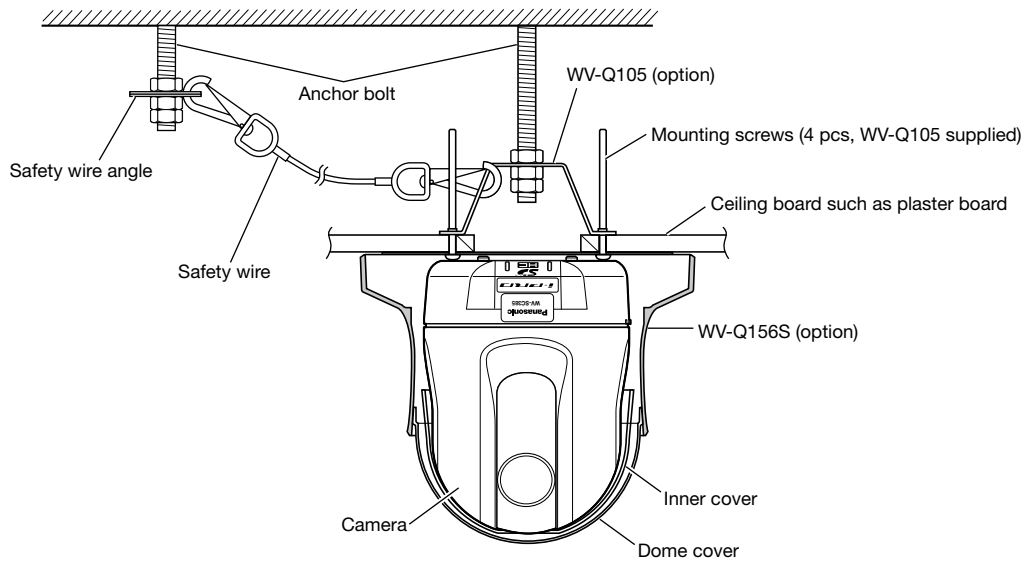

Connection example

When connecting with a PC directly

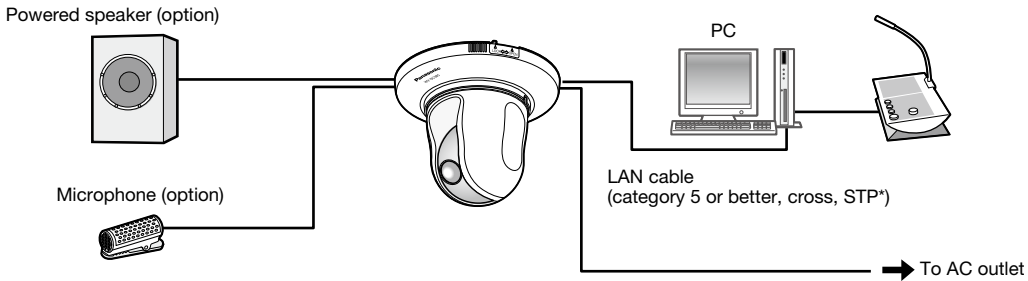

<Required cable>

LAN cable (category 5 or better, cross, STP*)

* PAL model only

When connecting to a network using a PoE hub

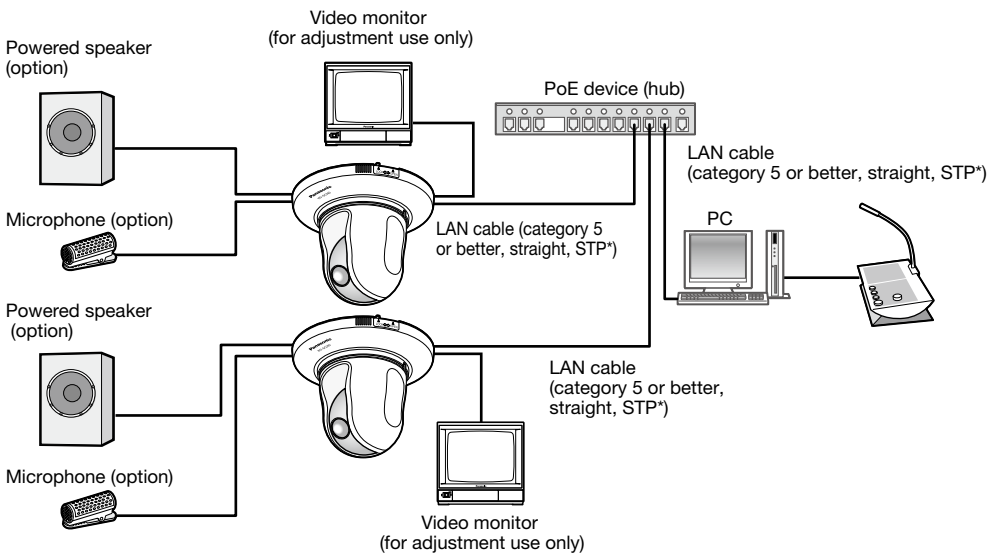

<Required cable>

LAN cable (category 5 or better, straight, STP*)

* PAL model only

Important:

- The video monitor is used for checking the adjustment of the angular field of view when installing the camera or when servicing. It is not provided for recording/monitoring use.
 - Depending on the monitor, some characters (camera title, preset ID, etc.) may not be displayed on the screen.
 - Use a switching hub or a router which is compliant with 10BASE-T/100BASE-TX.
 - Power supply is required for each network camera. When using a PoE device (hub), 12 V DC power supply is unnecessary.
-

Detach the camera

The camera is fixed on the camera mount bracket using the fixing screw. Remove the camera by following the instructions below.

Important:

- Do not detach the camera in a different way from the one described below. It may damage the camera.

Step 1

Rotate the decorative cover (accessory) counterclockwise until the indication "OPEN" reached the decorative cover guide of the camera mount bracket (accessory). Detach the decorative cover.

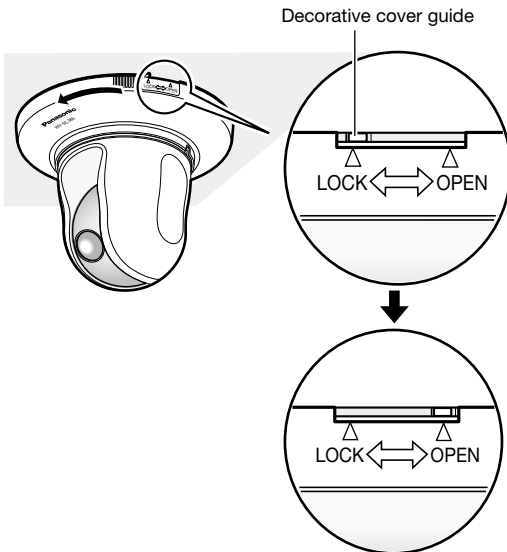

Step 2

Detach the 12 V DC power cable plug (accessory) and the LAN cable from the camera, and then turn off the power of the camera.

Step 3

Remove the fixing screw (accessory) that is fixing the camera on the camera mount bracket (accessory). Do not lose the fixing screw.

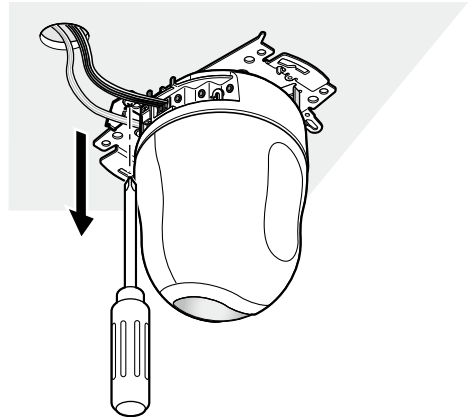

Step 4

Rotate the camera counterclockwise to detach the camera from the camera mount bracket (accessory).

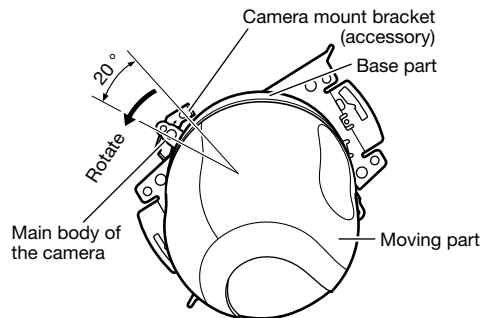

Important:

- When detaching the camera from the camera mount bracket, hold the base of the camera. Detaching the camera while holding the moving part may result in malfunction.

Step 5

Detach the cables from the camera.

Step 6

Detach the safety wire from the camera.

Insert/remove an SDHC/SD memory card

How to insert an SDHC/SD memory card

Important:

- Before inserting the SDHC/SD memory card, turn off the power of the camera first.
- When inserting an SDHC/SD memory card, make sure the direction.
- When the SDHC/SD memory card is inserted or removed with the power on, data in the SDHC/SD memory card may be damaged.

Step 1

Push the left corner of the Panasonic logo plate on the front panel to unlock the SDHC/SD memory card slot cover.

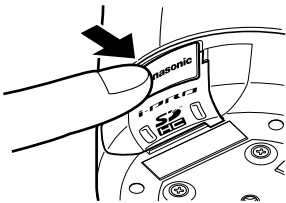

Step 4

Shut the SDHC/SD memory card slot cover and lock the cover by pushing the Panasonic logo plate.

Step 2

Slide the SDHC/SD memory card slot cover to the left to expose the slot.

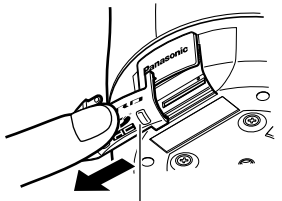

SDHC/SD memory card slot cover

Step 3

Insert an SDHC/SD memory card fully into the SDHC/SD memory card slot until a click is heard.

SDHC/SD memory card slot

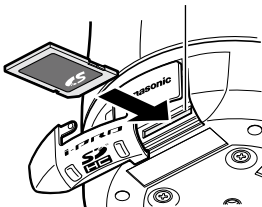

How to remove the SDHC/SD memory card

Important:

- Before removing the SDHC/SD memory card, select "Not use" for "SD memory card" on the [SD memory card] tab of the "Basic" page on the setup menu first. (Operating Instructions (PDF))
-

Step 1

Open the SDHC/SD memory card slot cover by following steps 1 and 2 of the "How to insert an SDHC/SD memory card" section.

Step 2

Push the SDHC/SD memory card until a click is heard and then pull the SDHC/SD memory card from the slot.

Step 3

Shut the SDHC/SD memory card slot cover and lock the cover by pushing the Panasonic logo plate.

Configure the network settings

Install the software

Before installing the software, refer to the readme file on the provided CD-ROM first.

Software included on the provided CD-ROM

- Panasonic IP setting software
Configure the network settings of the camera. Refer to the following for further information.
- Viewer Software "Network Camera View 4S"
It is necessary to install the viewer software "Network Camera View 4S" to display images on a PC. Install the viewer software by double-clicking the "nwc4Ssetup.exe" icon on the provided CD-ROM.

Configure the network settings of the camera using the Panasonic IP setting software

It is possible to perform the network settings of the camera using the IP setup software on the provided CD-ROM.

When using multiple cameras, it is necessary to configure the network settings of each camera independently.

If the Panasonic IP setting software does not work, configure the network settings of the camera and the PC individually on the "Network" page of the setup menu. Refer to the Operating Instructions (PDF) for further information.

Important:

- When using Microsoft Windows 7 or Microsoft Windows Vista, the "Windows Security Alert" window may be displayed when starting the IP setup software. In this case, disable "User Account Control" from the control panel.
 - For a security countermeasure, the MAC address/IP address of the camera to be configured will not be displayed when around 20 minutes have passed after turning on the power of the camera. (When "Easy IP Setup accommodate period" is set to "20min")
 - Panasonic IP setting software is inoperable in other subnets via the same router.
 - This camera cannot be displayed or set with an older version of the IP setup software (version 2.xx).
-

Step 1

Start the Panasonic IP setting software by double-clicking the "EasyIpSetup.exe" icon on the provided CD-ROM. The License Agreement will be displayed. Read the Agreement and choose "I accept the term in the license agreement", and click "OK".

Step 2

Click the [Network Settings] button after selecting the MAC address/IP address of the camera to be configured.

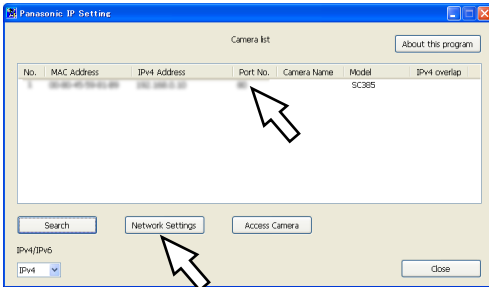

Note:

- When using a DHCP server, the IP address assigned to the camera can be displayed by clicking the [Search] button of the IP setting software.
- When a duplicate IP address is used, the corresponding camera number will be displayed shaded.
- When the [Access Camera] button is clicked, live images of the selected camera will be displayed.
- It is possible to change the "Camera list" display between IPv4 addresses and IPv6 addresses in accordance with the protocol in use.

Important:

- It may take for around 2 minutes to complete to upload the settings to the camera after clicking the [Save] button. The settings may be invalidated when the 12 V DC power supply is cut or when the AC adapter or the LAN cable is disconnected before completing the upload. In this case, perform the settings again.
- When using a firewall (including software), allow access to all UDP ports.

Step 3

Complete each network setup item and click the [Save] button.

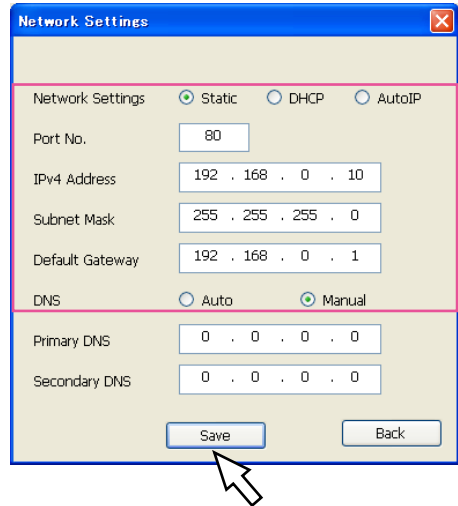

Note:

- When selecting "DHCP" or "AutoIP", it is possible to set "DNS" to "Auto".

Troubleshooting

Before asking for repairs, check the symptoms with the following table.

Contact your dealer if a problem cannot be solved even after checking and trying the solution in the table or a problem is not described below.

Symptom	Cause/solution	Reference pages
Power is not turned on.	<p>When using DC power supply</p> <ul style="list-style-type: none"> Is the 12 V DC power cable plug (accessory) firmly inserted into the 12 V DC power terminals of the camera? Confirm the power plug is firmly connected. 	18
	<p>When using a PoE device for power supply</p> <ul style="list-style-type: none"> Are the PoE device and the network connector on the rear of the camera connected using a LAN cable (category 5, STP*)? Check whether the connection is appropriately established. * PAL model only Depending on the PoE device, the power supply will stop when the demanded power exceeds its total power limit for all PoE ports. Refer to the operating instructions of the PoE device in use. 	18
The camera does not move to the preset positions accurately.	<ul style="list-style-type: none"> When the preset positions becomes inaccurate during use, it is possible to correct the positions by executing the position refresh function. In addition, when "Position refresh" is set for the created schedule, the camera position will be corrected periodically. In some situations, reconfigure the preset positions. 	Operating Instructions (PDF)
When the camera is panning/tilting, the camera stops panning/tilting and mechanical noise comes from the camera.	<ul style="list-style-type: none"> The camera position may have become inaccurate. Carry out the refresh position function from the [Default reset] tab of the setup menu. 	Operating Instructions (PDF)
The camera starts panning unpredictably.	<ul style="list-style-type: none"> This may be caused by noise. Check the exogenous noise level around the camera. 	11
When using an optional inner cover, upper side of images are hidden (become black) when the tilt angle of the camera is almost level.	<ul style="list-style-type: none"> This is not malfunction. This is caused by the shape of the inner cover (WV-Q157 or an accessory of optional mount bracket). In this case, images may also be washed out depending on the photographic subject when "On" is selected for "AGC" on the setup menu. 	12
When the power is turned on, the live indicator lights or blinks orange.	<ul style="list-style-type: none"> Is the LAN cable connected appropriately? Connect the LAN cable appropriately. Is the hub or router connected to the camera operating appropriately? Check if the hub or router in use is operating appropriately. Isn't the LAN cable connected to the camera broken? Replace the cable with another one. 	18

Symptom	Cause/solution	Reference pages
Live indicator keeps on blinking orange approx. in 2 seconds intervals.	<ul style="list-style-type: none"> • UPnP™ error has occurred since the power is not supplied to the router. Turn on the power of the router. Wait until the connections are established. 	-
	<ul style="list-style-type: none"> • An error has occurred during the port update by the UPnP function. • If the router in use does not support the UPnP function, perform the port forwarding setting for the router. In addition, deactivate the setting of auto port forwarding for the camera. 	Operating Instructions (PDF)
	<ul style="list-style-type: none"> • UPnP function of the router is disabled. Refer to the operating instructions of the router to enable the UPnP function. 	-
Live indicator never lights up.	<ul style="list-style-type: none"> • Is "Off" selected for "Link/Access LED" on the "Basic" page? Select "On" or "On(Access)" for the indicator setting. 	Operating Instructions (PDF)
Live indicator keeps on blinking red.	<ul style="list-style-type: none"> • The camera may be out of order. Contact your dealer. • Refer to the readme file on the provided CD-ROM for further information after checking the displayed contents of the "Maintenance" page - the [Status] tab - "Self check" of the setup menu. Or refer to our website (http://panasonic.net/pss/security/support/info.html) for further information about the supported software. 	-
Live indicator lights red.	<ul style="list-style-type: none"> • Isn't the write protect switch of the inserted SDHC/SD memory card set to "LOCK"? Unlock the write protect switch of the SDHC/SD memory card. • Hasn't the inserted SDHC/SD memory card been formatted on a PC? Use an SDHC/SD memory card formatted on the camera. Or install the software to format the SDHC/SD memory card on the PC. Refer to our website (http://panasonic.net/pss/security/support/info.html) for further information about the supported software. • Isn't the inserted SDHC/SD memory card faulty? Replace the card with a normal one. 	Operating Instructions (PDF)

Symptom	Cause/solution	Reference pages
<p>Cannot access the camera.</p>	<ul style="list-style-type: none"> • Are you accessing the wrong IP address? Check the connection as follows With the Windows command prompt, > ping "IP address of the camera" If there is reply from the camera, the connection is normal. If not, proceed either of the following. <ul style="list-style-type: none"> • Reboot the camera and change the IP address by using the Panasonic IP setup software within 20 minutes after the restart. • Reboot the camera while holding the [INITIAL SET] button on the camera. The camera will be initialized and the IP address will return to the default setting "192.168.0.10".After the camera is initialized, access the camera and set the IP address again. (When the camera is initialized, all the settings of the camera previously configured on the setup menus will be initialized.) • Are the IP addresses (local addresses) of the different classes used for the PC and the camera? The addresses (local addresses) of the same class must be set for the PC and the camera to be used in the same network. Change the IP address by using the "Panasonic IP setting" software. Then, access the camera again. 	<p>–</p>
<p>No live image is displayed.</p>	<ul style="list-style-type: none"> • Is the viewer software installed on the PC? Install the viewer software on a PC. (☞ Page 28 "Check camera images on a PC") 	<p>–</p>

About the live indicator

The live indicator will light or blink as follows depending on the camera status.

Operation status		Indicator status
When the power is turned on	Before the network connection is established	Blinks orange
	When the network connection is established	Blinks orange → Blinks green → Lights green
During the standby or connection (Cable is not connected.)		Lights orange
During the standby or connection (Cable is connected.)		Lights green
During the upgrade process		Blinks orange
During the initialization		Blinks orange → Lights off (Restarts in a few minutes.)
Port forwarding error caused by the UPnP function		Blinks orange (in 2 seconds intervals (on for 1 second / off for 1 second))
Trouble happening on the camera		Blinks red
Failure in writing data on the SDHC/SD memory card		Lights red

Specifications

• Basic

Power source:	12 V DC, PoE (IEEE802.3af compliant)
Power consumption:	WW-SC385: 12 V DC*: 1 A, PoE 48 V: 12 W/230 mA (Class 0 device) WW-SC384: 12 V DC*: 690 mA, PoE 48 V: 10 W/190 mA (Class 0 device) * FOR UL LISTED MODEL(S), ONLY CONNECT 12 V DC CLASS 2 POWER SUPPLY.
Ambient operating temperature:	-10 °C to +50 °C {14 °F to 122 °F}
Ambient operating humidity:	Less than 90 % (no condensation)
Monitor output:	VBS: 1.0 V [p-p]/75 Ω, composite (BNC), ø3.5 mm mini jack (monaural)
External I/O terminals:	ALARM IN 1, ALARM IN 2/ALARM OUT, ALARM IN 3/AUX OUT (x1 each)
Microphone/Line input:	ø3.5 mm monaural mini jack Input impedance: Approx. 2 kΩ
For microphone input:	Applicable microphone: Plug-in power type Supply voltage: 2.5 V ±0.5 V
For line input:	Input level: Approx. -10 dBV
Audio output:	ø3.5 mm stereo mini jack (monaural output) Output impedance: Approx. 600 Ω Line level
Dimensions:	ø115 mm x 155 mm (H) {ø4-17/32 inches x 6-3/32 inches (H)} (excluding the 12 V DC power cable plug)
Mass:	Camera: Approx. 900 g {1.99 lbs} Accessories (Camera mount bracket, decorative cover): Approx. 200 g {0.44 lbs}
Finish:	Camera: PC/ABS resin (Coating color: Fine silver (501)) Transparent part: PMMA resin

• Camera

Image sensor:	1/3 type MOS image sensor
Effective pixels:	Approx. 1.3 megapixels
Scanning area:	4.80 mm (H) × 3.60 mm (V) {3/16 inches (H) × 5/32 inches (V)}
Scanning system:	Progressive
Minimum illumination (SC385):	Color: 0.5 lx {0.05 footcandle} (F1.6, Auto slow shutter: Off (1/30 s), AGC: High, SD Off) 0.031 lx {0.0031 footcandle} (F1.6, Auto slow shutter: max. 16/30 s, AGC: High, SD Off)* BW: 0.06 lx {0.006 footcandle} (F1.6, Auto slow shutter: Off (1/30 s), AGC: High) 0.004 lx {0.0004 footcandle} (F1.6, Auto slow shutter: max. 16/30 s, AGC: High)* * Converted value
Minimum illumination (SC384):	Color: 0.6 lx {0.06 footcandle} (F1.6, Auto slow shutter: Off (1/30 s), AGC: High, WDR Off) 0.038 lx {0.0038 footcandle} (F1.6, Auto slow shutter: max. 16/30 s, AGC: High, WDR Off)* BW: 0.5 lx {0.05 footcandle} (F1.6, Auto slow shutter: Off (1/30 s), AGC: High) 0.031 lx {0.0031 footcandle} (F1.6, Auto slow shutter: max. 16/30 s, AGC: High)* * Converted value
Super Dynamic (SC385):	On/Off
Dynamic range (SC385):	52 dB typ. (Super Dynamic: On, Light control: Indoor scene)
Wide dynamic range (SC384):	On/Off
Face SD (SC385):	On/Off
Face WDR (SC384):	On/Off
Gain (AGC):	On(Low)/ On(Mid)/ On(High)/ Off
Adaptive black stretch:	On/Off
Light control mode setting:	Indoor scene (50 Hz)/ Indoor scene (60 Hz)/ Outdoor scene/ Fix shutter
Shutter speed:	1/30, 3/100, 3/120, 2/100, 2/120, 1/100, 1/120, 1/250, 1/500, 1/1000, 1/2000, 1/4000, 1/10000

Auto slow shutter:	Off (1/30 s), max. 2/30 s, max. 4/30 s, max. 6/30 s, max. 10/30 s, max. 16/30 s
Color/BW (SC385):	On/ Off/ AUTO1/ AUTO2/ AUTO3
Simple black & white mode (SC384):	Off/Auto
White balance:	ATW1/ ATW2/ AWC
Digital noise reduction:	High/Low
Image stabilizer:	On/Off
Video analytics	
Face detection:	On/Off (with the XML notification setting)
Privacy zone:	WV-SC385: On/Off (up to 8 zones available) WV-SC384: On/Off (up to 2 zones available)
Camera title on screen:	On/Off Up to 20 characters (alphanumeric characters, marks) WV-SC385: Character size: Large/Middle/Small WV-SC384: Character size: Small
Video motion detection	
(VMD alarm):	On/Off, 4 areas available
Image hold:	On/Off
Upside-down:	WV-SC385: On (desktop)/Off (ceiling) WV-SC384: Ceiling

• Lens

Zoom ratio:	18x 36x with Extra Optical Zoom (under VGA)
Digital (electronic) zoom:	WV-SC385: 12x (Max 432x combined with Extra Optical Zoom under VGA) WV-SC384: 8x (Max 288x combined with Extra Optical Zoom under VGA)
Focal length:	4.7 mm - 84.6 mm
Maximum aperture ratio:	1:1.6 (WIDE) - 2.8 (TELE)
Focus range:	1.5 m - ∞
Aperture range:	F1.6 - 22, Close
Angular field of view:	Horizontal: 3.2 ° (TELE) - 55.2 ° (WIDE) Vertical: 2.4 ° (TELE) - 42.1 ° (WIDE)

• Panning/tilting platform

Panning range:	0 ° - 350 °
Panning speed:	Manual: Approx. 0.5 °/s - 100 °/s, Preset: Up to approx. 300 °/s
Tilting range:	-30 ° to 90 ° (upward - level - downward) Selectable tilting angle: 10 ° / 5 ° / 3 ° / 0 ° / -3 ° / -5 ° / -10 ° / -15 ° / -20 ° / -25 ° / -30 °
Tilting speed:	Manual: Approx. 0.5 °/s - 100 °/s, Preset: Up to approx. 100 °/s
Number of the preset positions:	64
Auto mode:	Auto track (SC385)/ Auto pan/ Preset sequence/ 360 map-shot/ Preset map-shot
Self return:	10 s/ 20 s/ 30 s/ 1 min/ 2 min/ 3 min/ 5 min/ 10 min/ 20 min/ 30 min/ 60 min
Pan/Tilt-flip*:	On/Off
Map shot:	360 map-shot/Preset map-shot

* The pan/tilt-flip function cannot be activated by clicking live images. When the zoom ratio is adjusted to the "TELE" side, images will be partially hidden even if the pan/tilt-flip function is activated.

• Network

Network:	10BASE-T/100BASE-TX, RJ45 connector
Resolution (SC385):	Aspect ratio: 4:3 H.264 1280x960/ 800x600/ VGA(640x480)/ QVGA(320x240), max. 30 fps MPEG-4 VGA(640x480)/ QVGA(320x240), max. 30 fps JPEG (MJPEG) 1280x960/ 800x600/ VGA(640x480)/ QVGA(320x240), max. 30 fps Aspect ratio: 16:9 H.264 1280x720/ 640x360/ 320x180, max. 30 fps JPEG (MJPEG) 1280x720/ 640x360/ 320x180, max. 30 fps * MPEG-4 is not supported.

Resolution (SC384):	Aspect ratio: 4:3 H.264 1280x960/ VGA(640x480)/ QVGA(320x240), max. 30 fps MPEG-4 VGA(640x480)/ QVGA(320x240), max. 30 fps JPEG (MJPEG) 1280x960/ VGA(640x480)/ QVGA(320x240), max. 30 fps Aspect ratio: 16:9 H.264 1280x720/ 640x360/ 320x180, max. 30 fps JPEG (MJPEG) 1280x720/ 640x360/ 320x180, max. 30 fps * MPEG-4 is not supported.
Image compression method*1 *2:	H.264/MPEG-4 Image quality: Low/ Normal/ Fine Transmission type: Unicast/Multicast Audio bit rate: Constant bit rate/Best effort: 64 kbps/ 128 kbps/ 256 kbps/ 384 kbps/ 512 kbps/ 768 kbps/ 1024 kbps/ 1536 kbps/ 2048 kbps/ 3072 kbps/ 4096 kbps/ *8192 kbps * only in H.264 mode Frame rate: 1 fps/ 3 fps/ 5 fps/ 7.5 fps/ 10 fps/ 12 fps*/ 15 fps/ 20 fps/ 30 fps * PAL model only JPEG (MJPEG) Image quality: 0 SUPER FINE/ 1 FINE/ 2/ 3/ 4/ 5 NORMAL/ 6/ 7/ 8/ 9 LOW (10 steps: 0-9) Transmission type: PULL/PUSH
Transmission interval:	0.1 fps - 30 fps (JPEG frame rate will be restricted when displaying both JPEG and H.264/MPEG-4 images.)
Audio compression method:	G.726 (ADPCM) 32 kbps/16 kbps G.711 64 kbps
Bandwidth control:	Unlimited/ 64 kbps/ 128k bps/ 256 kbps/ 384 kbps/ 512 kbps/ 768 kbps/ 1024 kbps/ 2048 kbps/ 4096 kbps/ 8192 kbps
Protocol:	IPv6: TCP/IP, UDP/IP, HTTP, HTTPS, RTP, FTP, SMTP, DNS, NTP, SNMP, DHCPv6 IPv4: TCP/IP, UDP/IP, HTTP, HTTPS, RTSP, RTP, RTP/RTCP, FTP, SMTP, DHCP, DNS, DDNS, NTP, SNMP, UPnP
OS*3, *4:	Microsoft Windows 7 Professional (64-bit) Microsoft Windows 7 Professional (32-bit) Microsoft Windows Vista Business SP1 (32-bit) Microsoft Windows XP Professional SP3
Browser:	Windows Internet Explorer 8.0 (32-bit) (Microsoft Windows 7 Professional (32-bit/64-bit)) Windows Internet Explorer 7.0 (Microsoft Windows Vista Business SP1 (32-bit)) Microsoft Internet Explorer 6.0 SP3 (Microsoft Windows XP Professional SP3)
Maximum concurrent access number:	14 (Depends on network conditions)
FTP client:	Alarm image transmission, FTP periodic transmission (When the FTP transmission is failed, backup on an optional SDHC/SD memory card is available.)
Multi-screen:	Up to 16 camera images can be displayed simultaneously on a multi-screen. (Including the camera itself)
Compatible SDHC/ SD memory card (option):	Manufactured by Panasonic SDHC memory card: 4 GB, 8 GB, 16 GB, 32 GB SD memory card: 256 MB, 512 MB, 1 GB, 2 GB (except miniSD card and microSD card)
Cellular phone compatibility:	JPEG image, panning/ tilting/ zoom control, AUX control (by access level)

*1 Either H.264 or MPEG-4 is selectable.

*2 Transmission for 2 streams can be individually set in the same compression method.

*3 Refer to "Notes on Windows Vista® / Windows® 7" (PDF) on the provided CD-ROM for further information about system requirements for a PC and precautions when using Microsoft Windows 7 or Microsoft Windows Vista.

*4 When using IPv6 for communication, use Microsoft Windows 7 or Microsoft Windows Vista.

Standard accessories

Installation Guide (this document)	1 pc.
Warranty card (NTSC model only)	1 pc.
CD-ROM*1	1 pc.
Code label*2	1 pc.

*1 The CD-ROM contains the operating instructions (PDFs) and different kinds of tool software programs.

*2 This label may be required for network management. The network administrator shall retain the code label.

The following parts are used during installation procedures.

Camera mount bracket (w/safety wire)	1 pc.
Camera fixing screw	2 pcs. (incl. 1 spare)
Decorative cover	1 pc.
Power cable plug	1 pc.

Optional accessories

Wall Mount Bracket	WV-Q154S (Smoke dome type) WV-Q154C (Clear dome type)
Ceiling Embedding Bracket	WV-Q155S (Smoke dome type) WV-Q155C (Clear dome type)
Ceiling Mount Bracket	WV-Q156S (Smoke dome type) WV-Q156C (Clear dome type) WV-Q105 WV-Q157
Inner Cover	
User License Accessory (For MPEG-4)	BB-HCA5A (NTSC model) BB-HCA5CE (PAL model, Korea)* * Required in Korea.
User License Accessory (For H.264)	BB-HCA8A (NTSC model) BB-HCA8CE (PAL model, Korea)* * Required in Korea.

Important:

- When using an inner cover (WV-Q157 or an accessory of optional mount bracket), upper side of images will be hidden (become black) when the tilt angle of the camera is almost level. (When "-5°" is selected for "Tilt Angle" on the setup menu, upper half of images will be hidden.) In this case, images may also be washed out depending on the photographic subject when "On" is selected for "AGC" on the setup menu.
Refer to the Operating Instructions (PDF) for further information about the setup menu.
-

Information for Users on Collection and Disposal of Old Equipment and used Batteries



These symbols on the products, packaging, and/or accompanying documents mean that used electrical and electronic products and batteries should not be mixed with general household waste.

For proper treatment, recovery and recycling of old products and used batteries, please take them to applicable collection points, in accordance with your national legislation and the Directives 2002/96/EC and 2006/66/EC.

By disposing of these products and batteries correctly, you will help to save valuable resources and prevent any potential negative effects on human health and the environment which could otherwise arise from inappropriate waste handling.

For more information about collection and recycling of old products and batteries, please contact your local municipality, your waste disposal service or the point of sale where you purchased the items.

Penalties may be applicable for incorrect disposal of this waste, in accordance with national legislation.



For business users in the European Union

If you wish to discard electrical and electronic equipment, please contact your dealer or supplier for further information.

[Information on Disposal in other Countries outside the European Union]

These symbols are only valid in the European Union. If you wish to discard these items, please contact your local authorities or dealer and ask for the correct method of disposal.



Note for the battery symbol (bottom two symbol examples):

This symbol might be used in combination with a chemical symbol. In this case it complies with the requirement set by the Directive for the chemical involved.

Cd

For U.S. and Canada:

**Panasonic System Communications
Company of North America,
Unit of Panasonic Corporation of North America**

www.panasonic.com/business/
For customer support, call 1.800.528.6747
Three Panasonic Way, Secaucus, New Jersey 07094 U.S.A.

Panasonic Canada Inc.

5770 Ambler Drive, Mississauga, Ontario, L4W 2T3 Canada
(905)624-5010
www.panasonic.ca

For Europe and other countries:

Panasonic Corporation

<http://panasonic.net>

Importer's name and address to follow EU rules:

Panasonic Testing Centre
Panasonic Marketing Europe GmbH
Winsbergring 15, 22525 Hamburg F.R.Germany