



• User Manual •
Digital Enhanced Cordless Communication
SKYPE™ DECT TELEPHONE

Contents

Introduction	1
Physical Details.....	2
What the symbols mean.....	4
Setting up your telephone.....	4
Installation	5
Important safety information.....	6
Making and Answering Calls	7
Call Waiting (SKYPE / PSTN).....	7
Conference Calling	8
Phone Book.....	8
Call Lists	9
Settings	9
Extra Setting	13
SKYPE Function.....	13
Resetting the system	15
Intercom and transfer.....	15
Troubleshooting	16
Technical details.....	17
Declaration of conformity.....	18

Introduction

Overview

With the Skype DECT, you can make ordinary telephone call and Internet calls using Skype™ and SkypeOut.

- ♣ An ordinary telephone call is a call between two telephone line subscribers.
- ♣ A Skype™ call is between two registered Skype™ users. These calls are free of charge.
- ♣ A SkypeOut call is made via the Internet to an ordinary telephone number anywhere in the world using the Skype™ software.

In this user manual you will learn how to handle the different calls and learn how to navigate the handset menu.



Minimum System Requirements

- ♣ Broadband Internet Service
- ♣ PC with the following minimum specifications:
 - Pentium 400Mhz or above
 - Windows® 2000® or XP®
 - Available USB Port, USB2.0 or USB1.1
 - Skype® version 1.2 or higher (visit www.skype.com)
 - 128Mb RAM, 256Mb RAM recommended
 - 10Mb Hard Disk space
 - CD ROM for Software Driver

Package Content

The contents of your product should contain the following items. For any missing items, please contact your dealer immediately.

1. USB dongle
2. Telephone Cable
3. Rechargeable Battery
4. Power Adapter
5. DECT (Handset + Base)
6. Installation CD
7. User Manual
8. Earpiece Headset (Optional)
9. Handset Belt Clip (Optional)

NoteTo make Internet calls your PC must be turned on and the Skype™ software must be activated.

Physical Details

The USB dongle

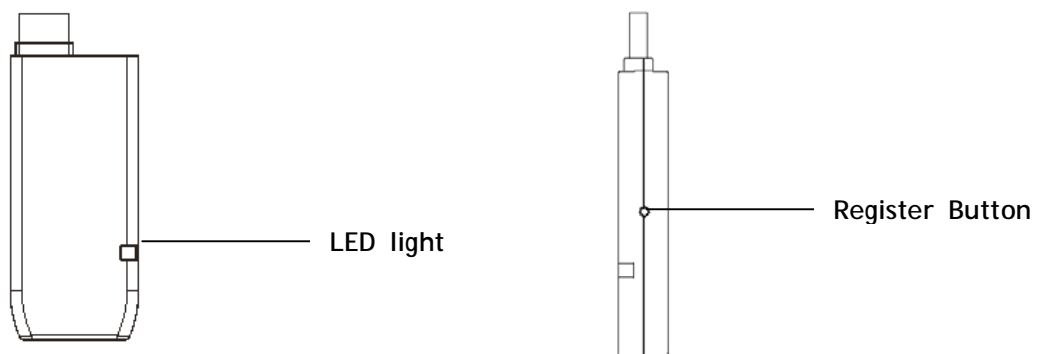

The Handset and Base Unit



Note:

Before you can use the handset to make calls for the first time, you will need to fit and fully charge the batteries for 15 hours.

What the symbols mean

Batteries Charge Level

Whenever this shows 'nearly empty' () , put the handset on the base unit to charge the batteries. While the batteries are being charged, the level shown will keep changing.



Mute

Your handset's microphone is muted.



Signal Level

Shows the signal between the handset and base unit, and disappear when you are out of range of the base unit.



Speakerphone

Your handset's loudspeaker is on.



Lock

Your handset's keypad is locked.

Setting up your telephone

Connection and conditions for use

You can connect your telephone to a direct exchange line (DEL), a line connected to a local exchange, with its own phone number; to an extension socket connected to a DEL; or to an extension on an approved compatible PBX. Do not connect the telephone as an extension to a payphone.

How many phones can you connect?

The ringer equivalence numbers (RENs) of all instruments (phones, fax machines, etc.) connected to an exchange line must not add up to more than 4, otherwise, one or more of them may not ring and/or answer calls correctly. The telephone has a REN of 1, and most other telephones have a REN of 1 unless marked otherwise.

Radio signals between handset and base unit

To use your handset and base unit together, you must be able to establish a radio link between them. Be aware that:

- Sitting the base unit as high as possible will give better results, in a two-storey house, the best position may be on the first-floor landing.
- Any large metal object, like a fridge, a mirror or a filing cabinet, between the handset and base unit may block the radio signal.
- Other solid structures, like walls, may reduce the signal strength.

Choosing a site for the base unit

The base unit should be placed on a level surface, in a position where:

- The mains adapter plug will reach a 230 V AC switched mains supply socket; never try to lengthen the mains power cable.
- The telephone cable will reach your telephone line socket or extension socket.
- It is not close to another telephone, this can cause radio interference.
- It is not close to a sink, bath or shower, or anywhere else where it might get wet.
- It is not close to other electrical equipment, fridges, washing machines, microwave ovens, TVs, fluorescent lights, etc.

Installation

1. Choose a suitable site for the base unit

Make sure it is not near to another telephone, nor to other electrical equipment.

2. Plug the mains power lead and the telephone line cord into the bottom of the base unit.

3. Plug the mains adapter into a 230 V AC, 50 Hz mains socket with the switch on the socket set to OFF.

Note: The illustration of adaptor may vary from country to country.

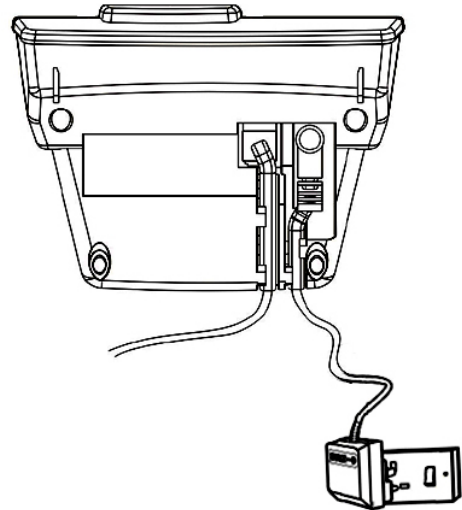

4. Switch on mains power at the socket

5. Fit the batteries in the handset(s)

Insert the batteries cell following the batteries polarity indication.

Push the latch inwards, and then slide the cover until it clicks firmly into position.

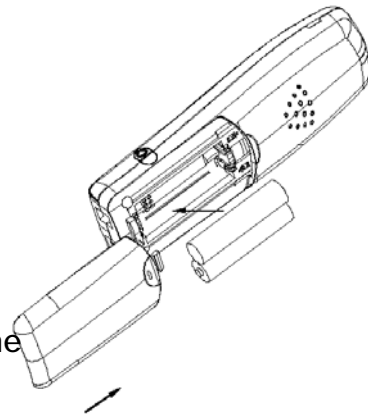

6. Connect the base unit to the telephone line

7. Plug in the USB dongle into PC USB port



8. Download the latest version of Skype™ from www.skype.com.

This is a Windows-based installation. If you have already installed the Skype™ software, proceed to the next step.

9. Mount the CD-ROM and install the program with CD installation provided.

The installation should run automatically. If it doesn't, begin the installation by opening the CD file namely **Setup** or **Skype Dect**. Follow the on-screen instructions to complete the installation.

After a successful installation, you will find an icon namely **Skype Dect** on the desktop.

Note: The Skype software must be activated on your PC before you place SkypeOut and Skype™ calls every time.

Important safety information

This equipment is not designed for making emergency calls in the event of a power failure. Alternative arrangements should be made for access to emergency services. (This means that you should also have a basic phone that does not need mains power, connected to your line so that you can make calls during a power failure)

People with a heart pacemaker should consult their doctor before using the telephone.

If you wear a hearing aid, you should note telephone works by transmitting radio waves between base and handset that may cause a humming noise.

1. **DO NOT** clean any part of your phone with benzene, thinner or other solvent chemicals, which may cause permanent damage to your phone. This damage is not covered by the Guarantee. When necessary, clean it with a damp cloth. Cleaning it with a wet cloth may give you an electric shock.
2. **DO NOT** use this equipment in places where volatile or explosive materials may be present.
3. **DO NOT** let the base unit get wet. Electrical equipment can cause serious injury if used while you are wet or standing in water. **NEVER** use your phone during a thunderstorm. Unplug the base unit from the telephone line and the mains socket when there are storms in your area. Damage caused by lightning is not covered by the Guarantee.
4. The telephone will produce a certain amount of heat during operation. For this reason it is recommended that this equipment is **NOT** placed in direct contact with antique, veneered or delicate furniture surfaces.
5. **DO NOT** dispose batteries with normal household waste, never burn them, or put them where they could get punctured.
6. The telephone DECT phone emits radio signals which could interfere with other electronic equipment, computers, radio, TV set, clock radio alarms, etc. A distance of at least one meter should be maintained between telephone base station and other equipment. This will minimize the risk of such interference.
7. When you do not need to carry your handsets around, leave them on the base unit or charger pod, to keep the batteries charged.
8. If you hear a warning tone as move around during a call, and/ or the sound in the earpiece becomes faint or distorted; you may be going out of range of the base unit. Move nearer to the base unit within 20 seconds, until the tone stops. Otherwise your call may be cut off.

Making and Answering Calls

Note: In standby mode, press any button on keypad except "Talk" button to make the backlight come on before enabling any function. (It means 1st press to turn on the backlight, 2nd press to activate the function button. This is correct for all buttons except for "Talk" button.)

To Make an Ordinary Call

1. Enter the telephone number and press Call key to place call;
2. If you make a mistake, press Right key to delete incorrect digits, before you press Call key.

To Answer an Ordinary Call

1. When the handset and base unit ring, press the Call key to answer call.
2. When the AUTO TALK is turned on, you can simply answer the call by lifting the handset from the base unit (see *AUTO TALK part*).

To End a Call

Press End key to hang up.

To Dial a Number from Call Logs

1. Select <Missed Calls>, <Received Calls> or <Dialed Calls> under *CALL LISTS* mode;
2. Press Left key, the display shows these calls;
3. Select the telephone number you want to call, then press the Call key to make call

To Redial a Call

In standby mode, press and hold the Call key to enter the dial list, and press the Scrolling button to scroll through the number you want to dial, then press the Call key to redial.

Earpiece Volume

During a call, you just press Scrolling button up/down to adjust the volume of the earpiece (0-9 level).

To Mute the Mouthpiece

1. During a call, press Left key once to mute the mouthpiece;
2. While the mouthpiece is muted, you cannot press any number key to send digits down the line;
3. Press Left key again to get back to the Call.

Call Waiting (SKYPE / PSTN)

DECT telephone has a Call Waiting feature that works with Caller ID service from your telephone service operator. When you're engaged on a PSTN ongoing call, if you receive a second Skype call, your phone will use a call waiting signal to let you know another call is ringing in. This way, you can switch between Skype and PSTN callers, hook down Skype call or even make Skype conference call together.

To Hook down / up the Second Call (Skype Call)

1. When you already engaged on an ongoing call, if another Skype call is received, press Right key to enter option menu;
2. Then press Scrolling button to select *Hook up / Hook down*;
3. Press Left key to confirm.

To Toggle between Skype call and PSTN call

1. When you already engaged on an ongoing call, if another Skype call is received, press Right key to enter option menu;
2. Then press Scrolling button to select *Hook up* and press Left key;
3. Press Right key to enter option menu again;
4. Press Scrolling button to select *Switch*;
5. Press Left key to toggle the phone connection. (If you want to hook down the Skype call, press Right key to enter option and Scrolling button to select *Hook down*, then press Left key)

Conference Calling

You need to register with your fixed line network operator for conference calling service. It is dependant on service availability and subscription.

To Make an Ordinary Conference Call:

1. Connect the first party;
2. Press INT key, and the first party is put on hold;
3. Dial second party's phone number;
4. When connected, press and hold "#" button to connect the three parties together.

Note: Refer to Call Waiting section for how to make Skype Conference Call.

Phone Book

Up to 100 records could be stored in each handset's Phone Book. Each record can store up to 20 digits, and names of up to 10 characters. In standby mode, press Right key, and the display shows phonebook list.

To Enter Phone Book mode:

There are two ways to enter Phone Book mode as following:

- Select *Phonebook* under menu mode.
- Press Right key to enter *Phonebook* mode directly.

To Store New Number into Phonebook

1. In standby mode, press Right key, the display shows the stored number;
2. Press Left key, and goes to the location *New Entry*;
3. Then press Left key again, and key in the name;
4. Press Left key to confirm, and key in the number;
5. Now press Left key to store it.

To Delete a Number or All Numbers from Phonebook

1. Under Phonebook mode, press Scrolling button to scroll through the stored numbers
2. Select the number you want to delete, then press Left key, then Scrolling button till to the location *Delete*
3. Now press Left key to delete current number or all numbers; the display shows *Delete?*
4. Press Left key to delete the number/numbers.

To Modify (Change) a Number in Phonebook

1. Under Phonebook mode, press Scrolling button to scroll through the stored numbers;
2. Select the number you want to modify, then press Left key, then Scrolling button to the location *Edit Entry*;

3. Press Left key to confirm, and Right key to clear the old name, then key in the new name;
4. Press Left key to save the edit, also goes to the stored number; press Right key to clear the old number and key in the new number;
5. Then press Left key to save the change

To Check Memory

You can use this feature to see how many of your Phone Book's locations have been not used.

1. In standby mode, press Right key, enter Phonebook mode, the display shows the stored numbers;
2. Press Left key and Scrolling button to the location *memory*;
3. Press Left key, the display shows " n Free".

Call Lists

You must subscribe to Caller ID service from your service provider to use this feature.

Call Logs store information related to Received calls, Missed calls and Dialed calls. telephone can store up to a maximum of 30 calls, consisting of 10 Received, Missed and Dialed calls respectively.

To Check Call Records

1. Select *Call Lists* under menu mode;
2. Press Left key again, the display shows *Received Calls, Dialed calls, Missed Calls*;
3. Select the calls type you wish to check through Scrolling button, then press Left key, the display shows these calls numbers;
4. Select one number, then press left key, and Scrolling button to the location *Show Details*;
5. Press Left key, then the display shows the details of the call, including the call number, and the date and time the call is received, dialed or missed.

To Save Call

1. See steps 1-3 above;
2. Select one number, then press Left key and goes to the location *Save*
3. Press Left key, and key in the name;
4. Press Left key to confirm, and key in the number;
5. Press Left key to store it.

To Delete Call Records

1. See steps 1-3 above;
2. Select one number, then press Left key and Scrolling button to the location *Delete Current or Delete All*
3. Press Left key, the display shows "Delete?"
4. Press Left key to confirm.

Settings

To Enter Handset Settings Mode

1. Select *Settings* under *menu* mode;
2. Press Left key, select *Handset set* under *Setting* mode; the display shows *Wall Paper, Ringer Set, Auto-talk, Handset Name, Language*;

To Set Wall Paper

1. Select < *Wall Paper*> under *Handset Set* mode;
2. Press Left key to confirm, and press Scrolling button to scroll through the pictures;

3. Choose the picture you prefer, and then press Left key to confirm, now the picture is set to the wallpaper of the handset.

To Set External/Internal Ringer Volume

1. Select < *Ringer Set*> under *Handset Set* mode;
2. Press Left key to confirm, then Scrolling button to the location *ExternalVo/InternalVol*;
3. Press Left key and Scrolling button to choose the volume level you want to set;
4. Then press Left key to confirm the choice.

To Set External/Internal Ringer Melody (1 - 9 melody)

1. Select < *Ringer Set*> under *Handset Set* mode;
2. Press Left key to confirm, then Scrolling button to the location *ExternalRing / InternalRing*;
3. Press Left key and Scrolling button to choose the ring melody you want to set;
4. Then press Left key to confirm the choice.

To Set Key Tone On/Off

Each time you press a key on your handset, you hear a tone. You can turn this off if needed.

1. Select < *Ringer Set*> under *Handset Set* mode;
2. Press Left key to confirm, then Scrolling button to the location *Key Beep*;
3. Press Left key and Scrolling button to set the key beep ON/OFF;
4. Press Left key to confirm.

Auto Talk Function

Normally, you need to press the Call button to answer an incoming call. But with *AUTOTALK* function turned on, when your handset is ringing for an incoming call, you can answer the call by simply lifting the handset from the base unit without pressing the Call button.

To Set Auto-Talk Function ON/OFF

1. Select < *Auto-talk*> under *Handset Set* mode;
2. Press Left key, and Scrolling button to set Auto-talk ON/OFF;
3. Then press Left key to confirm

Note: If you have turned Auto-talk on, do not press the Call button after you've answered a call by lifting the handset, otherwise, you'll disconnect the call.

To Set Handset Name

1. Select < *Handset Name*> under *Handset Set* mode.
2. Press Left key to confirm.
3. Key in your chosen name.
4. Then press Left key to confirm.

To Change Handset Name

1. Select < *Handset Name*> under *Handset Set* mode.
2. Press Left key to confirm, the display shows the current name.
3. Press and hold the Right key to clear the old name, then key in the new name.
4. Press Left key to confirm to the change.

To Set Language

You can select the language from the menu up to your preference.

1. Select < *Language*> under *Handset Set* mode;
2. Press Left key and Scrolling button to choose the language you prefer;
3. Then press Left key to confirm the setting

To Lock /Unlock the Keypad

Press Left key and " * " button consecutively to lock/unlock the keypad.

To Enter Base Settings Mode

1. Select *Settings* under *menu* mode;
2. Press left key select *Base Settings* and the display shows *Ringer Settings, Dial Settings, Call Barring, LCR(Optional), PIN* and *Default Settings*.

To Set Base Volume

1. Select < *Ringer Settings*> under *Base Settings* mode;
2. Select <*Ringer Volume*> under *Ringer Settings*;
3. Press Left key and Scrolling button to set the volume you like;
4. Press Left key to confirm.

To Set Base Melody (1-9 melody)

1. Select < *Ringer Settings*> under *Base Settings* mode;
2. Select <*Ringer Melody*> under *Ringer Settings*;
3. Press Left key Scrolling button to set the melody you prefer;
4. Press Left key to confirm.

To Set Flash Time

You can change flash time to short or long.

1. Select < *Dial Settings*> under *Base Settings* mode;
2. Select <*Flash Time*> under *Dial Settings*;
3. Press Left key and Scrolling button to change Flash Time to Long or Short;
4. Press Left key to confirm

To Set Auto Pause

When you call a number with a pause, the phone waits a few seconds before transmitting the next digits in the dialing sequence. This is useful when you have to dial a number for access to an outside line, or for going into a voicemail system. You are allowed to set one number in Auto Pause

1. Select < *Dial Settings*> under *Base Settings* mode;
2. Select <*Auto Pause*> under *Dial Settings*;
3. Press Left key, then key in PIN (default 0000)
4. Press Left key, then key in the number you want to set auto pause;
5. Press Left key to confirm.

To Set Dial Mode

You can change dial mode to TONE or PULSE dialing.

1. Select < *Dial Settings*> under *Base Settings* mode;
2. Select <*Dial Mode*> under *Dial Settings*;
3. Press Left key and Scrolling button to change dial mode as TONE or PULSE;
4. Press Left key to confirm.

Call Barring Function

Call barring enables you to restrict or bar certain types of calls from your phone.

To Set Call Barring Number

1. Select < *Call Barring*> under *Base Settings* mode;
2. Select <*Barring Number*> under *Call Barring*;
3. Press Left key, then key in the PIN (the default PIN is 0000);
The display shows the numbers from 1 to 5 (the maximum call barring numbers you can set)
4. Press Left key and then key in the telephone number you want to set call barring.
5. Press Left key to confirm.

To Delete Call Barring Number

1. See 1-3 step above, press the Scrolling button to select the call barring number you want to delete;

2. Then press Left key, the display shows the call barring number you set;
3. Press and hold Right key to clear the number;
4. Press Left key to confirm.

Least cost route (LCR) function (Optional)

With the LCR function, the phone will automatically replace a long number with a comparative short number, to simplify the process of dialing a long number. For example, if the user program to replace "00" with "1790900", then when he dials "006567417211", then the phone will automatically replace the number to be dialed out as "17909006567417211".

To Set LCR

1. Select <LCR> under *Base Settings* mode;
2. Press Left key, and key in the PIN;
3. Press Left key, then key in the SHORT number that you want to replace the long number;
4. Press Left key to confirm, then key in the LONG number;
5. Press Left key to confirm.

To Change Base PIN

1. Select <PIN> under *Base Settings* mode;
2. Press Left key, and key in the original PIN (default PIN:0000) number;
3. Then press Left key to confirm, and key in New PIN;
4. Press Left key, then key in New PIN again;
5. Press Left key to confirm.

Default Settings

1. Select <Default settings> under *Base Settings* mode;
2. Press Left key, and key in the current PIN number;
3. Press Left key to confirm, you will hear a beep, then all features will return to their default settings.

The following default settings are for your reference:

1. Reset Flash time to Long
2. Delete call barring number.
3. Reset master pin number to 0000.
4. Reset ringer melody and volume.
5. Dial mode reset to Tone.
6. Remove Auto Pause number.
7. Remove LCR (if available).

Registration

Your telephone is supplied with the handset and USB dongle already registered to the base unit; you shouldn't need to register them. But if you've bought extra handset, you'll need to register each one to your original base unit. Maximum another 3 handsets can be registered to one base.

To Enter Registration Mode

1. Select *Settings* under *menu* mode;
2. Press Left key, select *Registration* and the display shows *Select Base, Base Sub* and *De-register*.

To register a handset

1. Select *Base Sub* under *Registration* mode;
2. Press Left key again, you will see *BASE 1; BASE 2; BASE 3; BASE 4;*
3. Press Scrolling button to scroll through the base, and press Left key to select.
4. Press and hold the **Handset locator** button on the base unit for a while, until you hear "beep" sound twice continuously then let go.
5. Handset will find the base, press Left button to confirm. Enter base PIN(Default: 0000), and press Left key to confirm.

6. After a while, when the handset finds the base unit, it goes back to the standby mode.

To de-register a handset

You may need to do this if you have more than one handset registered to your base unit and you need to replace a faulty handset.

1. Select *<de-register>* under *REGISTRATION* mode.
2. Press Left key, then key in the PIN (default 0000).
3. Press Left key, then key in the number of the handset you want to de-register.
4. Press Left key to confirm.

Note: You cannot de-register the handset you are currently using.

To register a USB dongle

1. Press and hold the Handset locator button on the base unit for a while, until you hear "beep" sound twice continuously;
2. Insert the USB dongle into your PC USB port, the LED will be blinking.
3. Use a paper clip or a pencil tip to depress and hold the reset button of dongle for 2~3 seconds, then release and you will hear a confirmation tone from Base unit.
4. Once registered successfully, the LED on the dongle will be turned on permanently.

Extra Setting

To Set Alarm Time

1. Select *EXTRA* under menu mode;
2. Select *< Alarm Set >* under *EXTRA* mode;
3. Press Left key, then press Scrolling button to goes to location *ON*;
4. Press Left key, then key in the time;
5. Press Left key to save;

To Set Clock Time

1. Select *< Clock Set >* under *EXTRA* mode;
2. Press Left key, then key in the time;
3. Press Left key to save;

To Set Date

1. Select *<Date Set >* under *EXTRA* mode;
2. Press Left key, then key in the date;
3. Press Left key to save;

SKYPE Function

To Make a SkypeOut Call

SkypeOut allows you to use your Internet connection to call ordinary telephones and mobile telephones worldwide.

- Enter the telephone number you wish to call and the symbol "SkypeOut" appears on the left bottom of display, then press Left key to place call.

Note: The Skype software must be activated on your PC in order to perform SkypeOut and Skype™ calls. To perform SkypeOut calls you also need to set up a user account and top up with call credit at www.skype.com

To Call a Skype™ User

Make sure the Skype™ user is available in your Skype net Contact list and is online. Otherwise, add the online Skype™ user name you wish to call to the Contacts list of Skype net fist. It will automatically appear in your phone's Skype list. To call a Skype™ user:

1. Press Scrolling Up button to enter Skype mode directly, the display shows the stored names;
2. Press Scrolling Up / Down button to select the name you wish to contact;
3. Press Call key to make call;

To Make Skype Out Call from Phonebook

1. Under Phonebook mode, press Scrolling button to select the call number you wish to call;
2. Press Left key to enter *Option* menu, then Scrolling button to the location *Skype out*;
3. Press Left key to place Skype Out call.

To Make Skype Call from Contact List

1. Select *Skype* under menu mode;
2. Select < *Contact List* > under Skype mode;
3. Press Left key, then the display shows the Skype online user list;
4. Press Scrolling button to select the record you wish to call;
5. Press Call key to place a Skype call.

Note: Press shortcut key Up-button in the scrollbar to enter the Skype contact list directly or use above steps.

Quick Search: This function enables you to speed search the list by inputting the initial letter or number of the list you look for. For example, if you would like to search a user namely " Linda" in your contact list, press "5" key, and then " J K L j k l 5 " box will be displayed on the screen. Press "5" key continuously until you select "L". Then it would perform search for you.



To Make Speed-Dial Call

1. Press the Speed-Dial number you like to call
2. Press Left key to place the call.

To Make SkypeOut Call from Call List

1. Select *Call Lists* under menu mode;
2. Press Left key again, the display shows *Received Calls, Dialed Calls, Missed Calls*.
3. Select the calls-type from *Received Calls, Dialed calls, Missed Calls* by Scrolling button, then press Left key, the display shows these calls numbers;
4. Select one number you wish to call, then press left key, and Scrolling button to the location *Skype Out*.
5. Press Left key to place Skype Out call.

To Make Skype Call from Skype Calllogs

1. Select *Skype* under menu mode;
2. Select < *Skype Calllogs* > under *Skype* mode;
3. Press Left key, then the display shows the Skype Calllogs indicating the Online Status of these users. Received Skype call marked with "  ", Dialed call marked with "  ", and Miss call marked with "  ".
4. Press Scrolling button to select the record you wish to call;
5. Press Call key to place a Skype call.

To Set User Status

1. Select *Skype* under menu mode;

2. Select < *User Status* > under *Skype* mode;
3. Press Left key, then the display shows the selection status;
4. Press Scrolling button to select the status you wish to set;
5. Press Left key to save.

To Set Skype Microphone and Speakerphone

1. Right click on the Skype DECT icon  located at the bottom-right hand side;
2. Select *Volume Control*;
3. Set the Speaker or MIC as required. Illustration below.

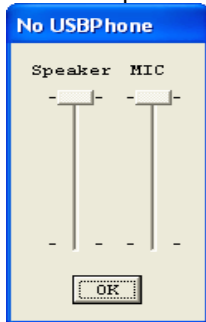

To Make a Skype Conference Call:

1. When you already engaged on an ongoing call, if another Skype call is received, press Right key to enter option menu;
2. Then press Scrolling button to select *Hook up* and press Left key;
3. Press Right key to enter option menu again;
4. Press Scrolling button to select *Conference Call*;
5. Press Left key to connect the three parties together.

Note: You cannot host a conference call by yourself but can be invited to participate in a conference call opened by the other Skype users.

Resetting the system

If you have set a PIN and forgotten it, you need to reset the system. The Base PIN will be reset to 0000. If you reset the system, you will lose all stored information (including numbers in memory) and all features will return to their default settings. You need to register the handset to the base unit again.

While you are resetting the system, you should disconnect the telephone line cord from the back of the base unit, so you won't be interrupted by incoming calls. To reset the system without the PIN:

1. Disconnect the power lead from the back of the base unit
2. Press and hold the **HANDSET LOCATOR** button in the base unit, at the same time connect the power lead into the back of base unit. Release the **LOCATOR** button after you hear "beep" sound for five times. The **IN USE** light on base unit lights during this whole process.
3. After 2-3 seconds, you can hear "beep" sound for two times again and the **IN USE** light goes off;
4. Disconnect the power lead from base. Reconnect and you will hear a confirmation tone from the base unit.

Intercom and transfer

To Make an Intercom Call

1. Press the INT key. You hear Dial tone
2. Key in the number of the other handset

On the other handset's display, your number appears, and the INT symbol flashes. Then the other handset user presses the Call key to connect the call.

For details of how to change the ringing melody and volume for intercom calls, see "INT MELODY" and "INT VOLUME" under "HANDSET SETTING" part.

To End an Intercom Call

Press the Call key on your handset. The other person will hear Busy tone, and also need to press the End key to hand up.

To transfer the outside call to another handset (if you have two or more handsets):

1. Press the INT key and key in the number of the other handset.
2. The outside call is put on hold. When the other handset answers, you can speak to the user. If the other handset does not answer, you can get back to the outside call by pressing the INT button again.

To transfer the outside call to another outside phone (Network Dependent):

1. Press the Recall key and key in the call number you want to transfer.
2. The outside call is put on hold. When the call answers, you can speak to the user, then press the End key to hang up and transfer the call.

Troubleshooting

Always check first that:

- You have followed the steps listed on pages to install and set up your telephone.
- All connects are firmly inserted in their sockets.
- Mains power is switched on at the socket.
- The handset's batteries are correctly and securely installed, and are not run down.

If you experience difficulties with the working of your telephone, refer to the advice given below.

I cannot make or answer calls.

Check that the base unit's mains power adapter is plugged in and power is switched on. The base unit needs mains power for normal operation of the phone-not just charging the batteries.

Make sure you are using the telephone line cable that was supplied with your telephone. Other telephone line cables might not work. Move the handset closer to the base unit. Check the batteries level symbol on the display. If it is low, replace the handset on the base unit or charger pod to recharge the batteries. Switch off power at the mains socket, wait for a few seconds and then switch back on. This may solve the problem. If you still can't make calls, try re-registering the handset.

When I press keys on the handset, nothing happens.

Make sure the batteries are fitted in your handset. If the batteries level symbol on the display shows "low", recharge the batteries. Check whether there's a key symbol on the display. If so, the keypad is locked. Turn to the user manual to find out how to unlock it.

When I press keys on the handset, digits appear on display, but I can't make an outside call.

Call barring may have been set, see the user manual for more information.

Try moving the handset closer to the base unit.

Try a different position for the base unit-perhaps higher, or further from other electrical equipment.

The phone does not ring

Check that the base unit's mains power adapter is plugged in and power is switched on. The base unit needs mains power for normal operation of the phone-not just charging the batteries.

Make sure you are using the telephone line cable that was supplied with your telephone. Other telephone line cables might not work.

Check that you have set the ringer volume to off. See the user manual for more information.

Check that the total REN value of all equipment connected to your telephone line is no more than 4. Disconnect one or more telephones and see whether that helps.

The base does not ring.

Check that the base power is ON, and the base ringer is set ON.

Check that the line cord is correctly fitted and undamaged.

The CHARGE light on the base unit does not come on."

Check the handset is properly stationed.

Check the connections between the base unit and mains power socket.

Clean the batteries charging contacts with a dry cloth.

When I press the CALL button, I hear a loud noise.

The strange noise is caused by interference. Disconnect the mains power lead from the back of the base unit, and then wait for 30 seconds before reconnecting it.

There is 'beep' sound while I am on a call.

You may be going out of range of the base unit. Move closer, or your call may be cut off.

Check the Batteries Level symbol on the display. If it is low, recharge the batteries.

The Caller Display feature isn't working.

You need to subscribe to the Caller Display feature from your service provider.

The caller may have withheld their number, or they may be calling from a network that does not transmit the Caller ID (for example, it may be an international call).

The handset's batteries are running low within an hour or two.

Before you used the handset for the first time, you should have left it on the base unit for up to 15 hours to charge the batteries fully. You may need to replace the batteries.

I cannot transfer a call.

Make sure the other handset is within range of the base unit, and is not busy on a call.

Make sure you are keying in the correct number for the other handset.

No display on LCD screen.

Make sure the batteries have power.

I cannot register handset to base

Make sure the number of handset registered to base is less than 3.

Check that the base unit is not near other electrical equipment, such as TV or computer

Technical details

Full DECT GAP Compatible system

Standard	Digital Enhanced Cordless Telecommunications (DECT)
Frequency range	1.88 to 1.9 GHz
Channel bandwidth	1.728 MHz
Modulation	GMSK
Operating range	Up to 300 m outdoors; Up to 50 m indoors
Operating time	Standby time: 100 hours, Talking time: 8 hours
Temperature range	Operating 0°C to 40°C, Storage -20°C to 60°C

Electrical power	Handset- One 1.2 x 2 V 750 mAH Ni-MH, Rechargeable battery cell
Base unit	Input 230 V AC, 50 Hz; Output AC 7.5V, 350 mA.
Headset Earpiece	2.5mm jack
PABX compatibility	Pause length: 3 seconds. Signaling type: DTMF (Dual-Tone Multifrequency) Pulse dialing

Declaration of conformity

The telephone complies with the essential protective requirements and objectives of:

- EC R& TTE Directive 1999/5/EC
- EC Low Voltage Directive 73/23/EEC
- EC EMC Directive 89/336/EEC

