

# WEISSCAM HS-2



## User Manual

ENGLISH

Before operating this product, please read the instruction carefully and save this manual for future use. Subject to technical change without any prior notice.

# WEISSCAM HS-2

## Manufacturer Information

The manufacturer of this product is

### **P+S Technik GmbH**

Siemensstraße 12  
85521 Ottobrunn/Munich  
Germany

Phone +49-(0)89-45 09 82-30  
Fax +49-(0)89-45 09 82-40  
Email [weisscam@pstechnik.de](mailto:weisscam@pstechnik.de)  
Web [www.pstechnik.de](http://www.pstechnik.de)

Please find worldwide authorised representation and dealer on our website [www.pstechnik.de](http://www.pstechnik.de) in the rental section or send an e-mail to [weisscam@pstechnik.de](mailto:weisscam@pstechnik.de) requesting the contact details.

Concerning any service and warranty requests, please contact your local distributor or P+S Technik directly by email at [helpdesk@pstechnik.de](mailto:helpdesk@pstechnik.de)

## Safety Notes



### Warning:

- To reduce the risk of fire or shock hazard, do not expose this equipment to rain or moisture.
- To reduce the risk of fire or shock hazard, keep this equipment away from all liquids. Use and store only in locations which are not exposed to the risk of dripping or splashing liquids, and do not place any liquid containers on top of the equipment.

### Caution:

To reduce the risk of fire or shock hazard and annoying interference, use the recommended accessories only.

### FCC Note:

This equipment has been tested and found to comply with the limits for a class A digital device, pursuant to Part 15 of the FCC Rules. These limits are designed to provide reasonable protection against harmful interference when the equipment is operated in a commercial environment. This equipment generates, uses, and can radiate radio frequency energy, and if not installed and used in accordance with the instruction manual, may cause harmful interference to radio communications. Operation of this equipment in a residential area is likely to cause harmful interference in which case the user will be required to correct the interference at his own expense.

### Warning:

To assure continued FCC emission limit compliance, the user must use only shielded interface cables when connecting to external units. Also, any unauthorized changes or modifications to this equipment could void the user's authority to operate it.



The lightning flash with arrowhead symbol, within an equilateral triangle, is intended to alert the user to the presence of uninsulated "dangerous voltage" within the product's enclosure that may be of sufficient magnitude to constitute a risk of electric shock to persons.



The exclamation point within an equilateral triangle is intended to alert the user to the presence of important operating and maintenance (service) instructions in the literature accompanying the appliance.

To prevent damages to the device, do not expose it to extreme moisture, rain, heat or dust. Do not open the device yourself. Have repairs carried out by qualified technicians in authorised specialist companies only.

- Do not touch the low-pass filter in front of the sensor.

# WEISSCAM

## HS-2

- To ensure reliable, proper operation, it is required that you familiarise yourself with this operating manual.
- Only use compatible power supply units/batteries that conform with the voltage range of the device.
- Any auxiliary equipment must not exceed the maximum permitted power.
- Ensure safe transport in the cases provided for this purpose.
- Keep all ventilation openings unobstructed to guarantee continuous cooling of the components.
- Disconnect the device from the power supply prior to care and maintenance tasks.
- Avoid direct light exposure of the sensor and do not touch the sensor.
- Do not use the camera without the lens or protective cap.
- Clean optical surfaces using optical cleaning agents only.

# Content

Manufacturer Information .....	2
Safety Notes .....	3
1. Overview .....	7
1.1 Features .....	7
1.2 Dimensions.....	8
1.3 Connections .....	13
2. Functional description.....	17
2.1 Setup .....	17
2.2 Operation .....	21
2.3 Updating the Firmware .....	40
2.4 Miscellaneous.....	42
3. Troubleshooting .....	49
4. Technical Specifications .....	53
5. Addresses and Contacts .....	57

# WEISSCAM

## HS-2

## 1. Overview

### 1.1 Features

The WEISSCAM HS-2 is the newest, uncompressed digital Highspeed Camera for framerates up to 4.000fps. It is developed as a Stand-alone camera aiming especially the needs of cinematographers. Coming with an easy workflow, two Streams (RAW + HD) via HD SDI, and cinema-style images, it is designed to offer you the freedom of shooting either in HD or RAW mode.

The WEISSCAM HS-2 has a full Format Super35 CMOS Sensor with a global shutter. By using the Interchangeable Mount System (IMS) from P+S TECHNIK you can attach nearly every lenses on the camera (PL Mount, Nikon F-Mount, Panavision Mount, etc.) and also change the Mount within a few seconds.

The output of the WEISSCAM HS-2 offers two Streams at the same time and uses the HD SDI interface for both signals. With the WEISSCAM "RAW IN HD SDI" mapping, you are able to transport the RAW files via the worldwide standard and fast HD SDI single and dual link interface.

The HD stream offers YCbCr in 4:2:2. You can choose between linear standard curves like ITU-R 709 or log curve for a higher contrast range within the HD SDI image.

The RAW stream is a 12Bit uncompressed WEISSCAM RAW file and gives you the freedom to debayer in post production.

In conjunction with the WEISSCAM DIGIMAG DM-2, you are able to record both formats via HD SDI: YCbCr and RAW.

An intelligent master/ slave DC/DC power management, saves the camera from any short circuit and makes it needless to turn off the camera for a battery change.

A lot of mounting possibilities allows you to connect additional accessories like onboard monitor, lens control system, etc. and power them by the several outputs of the DC/DC board.

The very fast boot up time allows you to be ready to shoot in less than 30 seconds.

# WEISSCAM HS-2

## 1.2 Dimensions

Dimensions of the external housing:

Height: 210.4 mm      Length: 315.9 mm      Width: 200.7 mm

Weight of camera body only: Approx. 6,8 kg

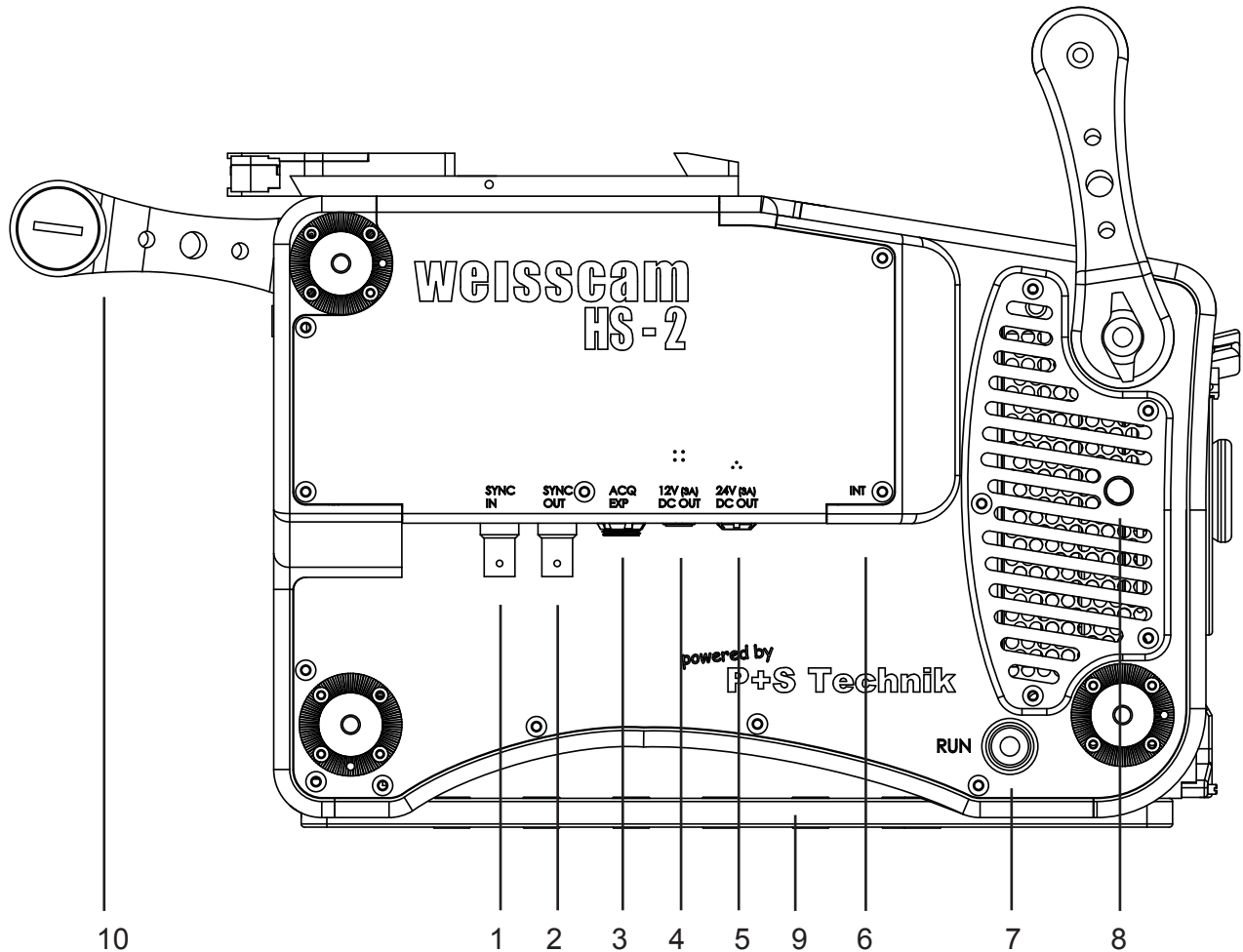

1. SYNC IN
2. SYNC OUT
3. ACQ EXP
4. 12V/3A DC OUT
5. 24V/3A DC OUT
6. INT - Debayerboard Firmware update

7. EXT. RUN trigger
8. Tape hook
9. Adapter plate
10. Handles



# WEISSCAM HS-2

1

Overview

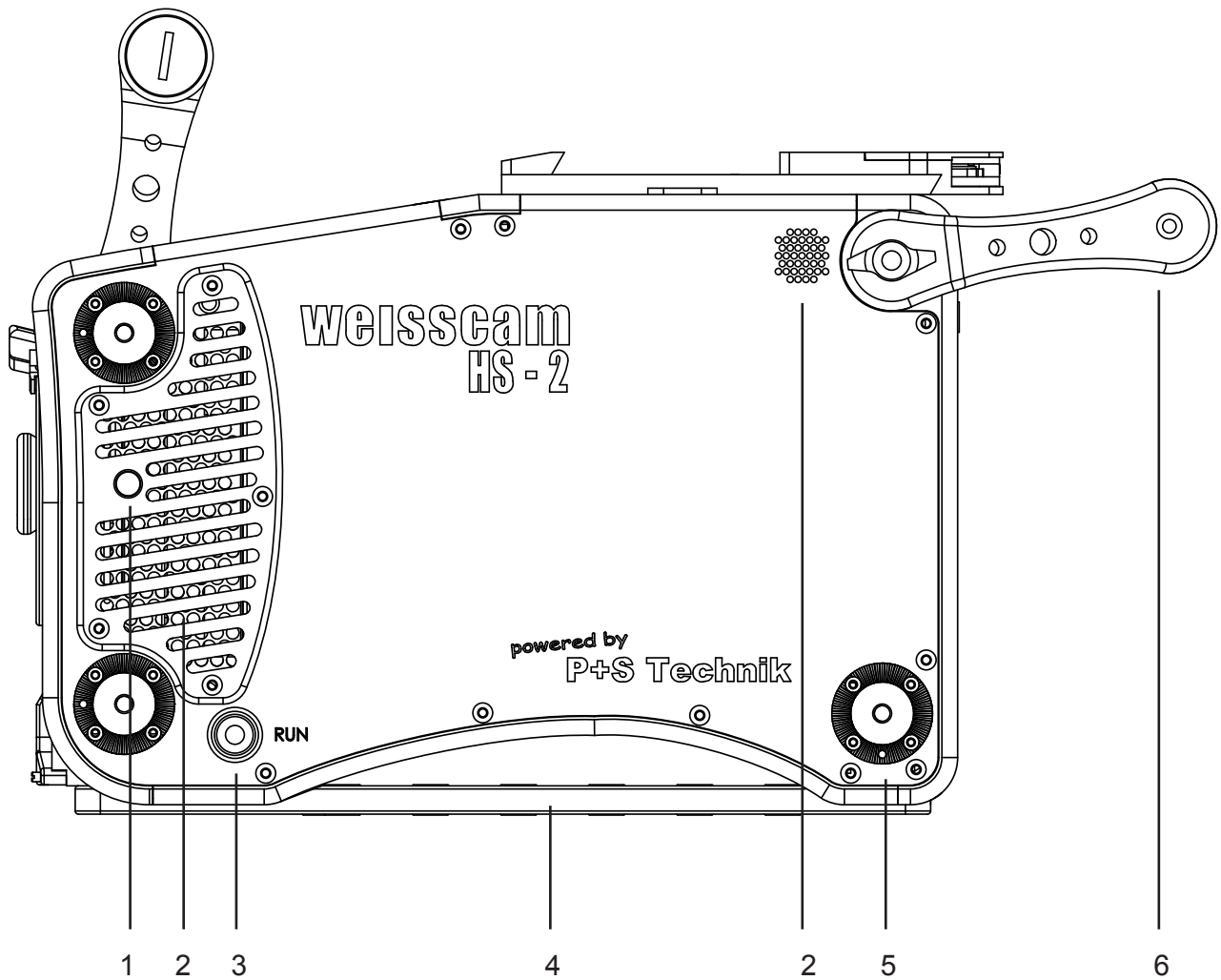

1. Tape hook
2. Ventilation exhaust air
3. EXT. RUN trigger
4. Adapter plate
5. Rosettes
6. Handles

# WEISSCAM HS-2

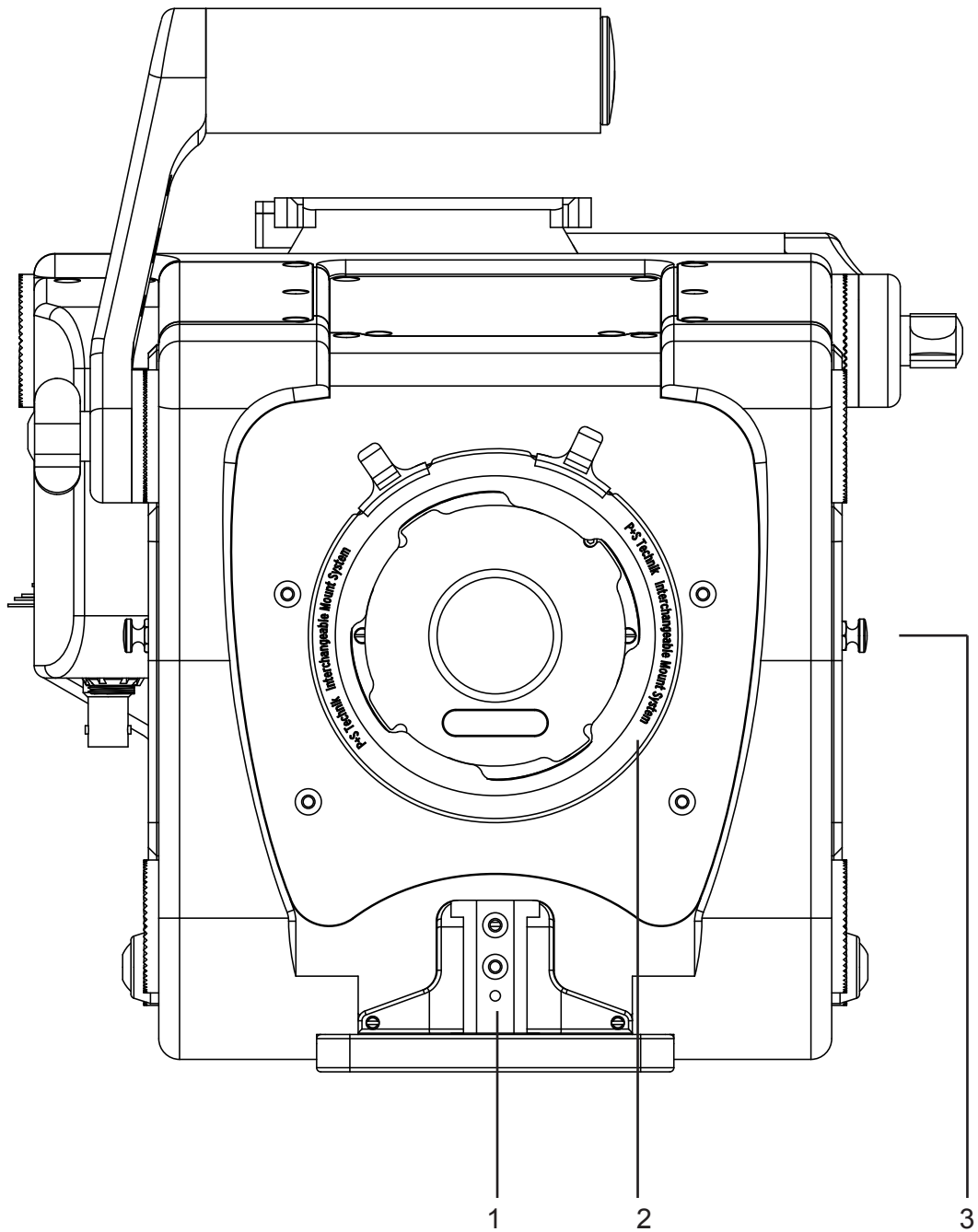

1. Accessory shoe for ARRI Lightweight Support

2. IMS Interchangeable Mount System  
3. Tape hook

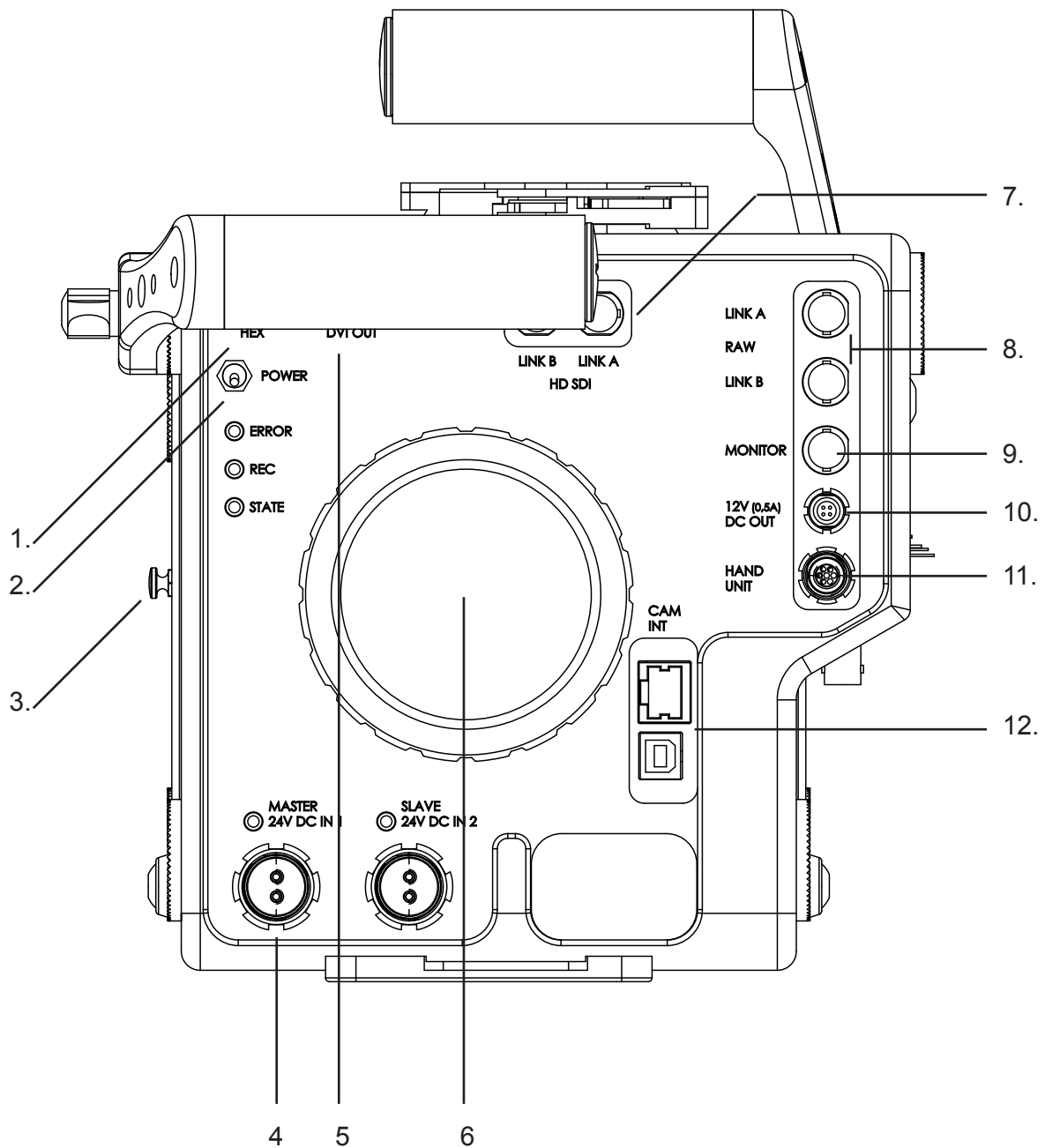

1. HEX switch
2. Power switch
3. Tape hook
4. MASTER / SLAVE 24V DC IN
5. DVI OUT
6. Ventilation, air supply

7. HD-SDI Link A & Link B
8. RAW Link A & Link B
9. Monitor OUT
10. 12V (0.5A) DC OUT
11. Hand Unit
12. CamINT (Ethernet / USB B)

# WEISSCAM HS-2

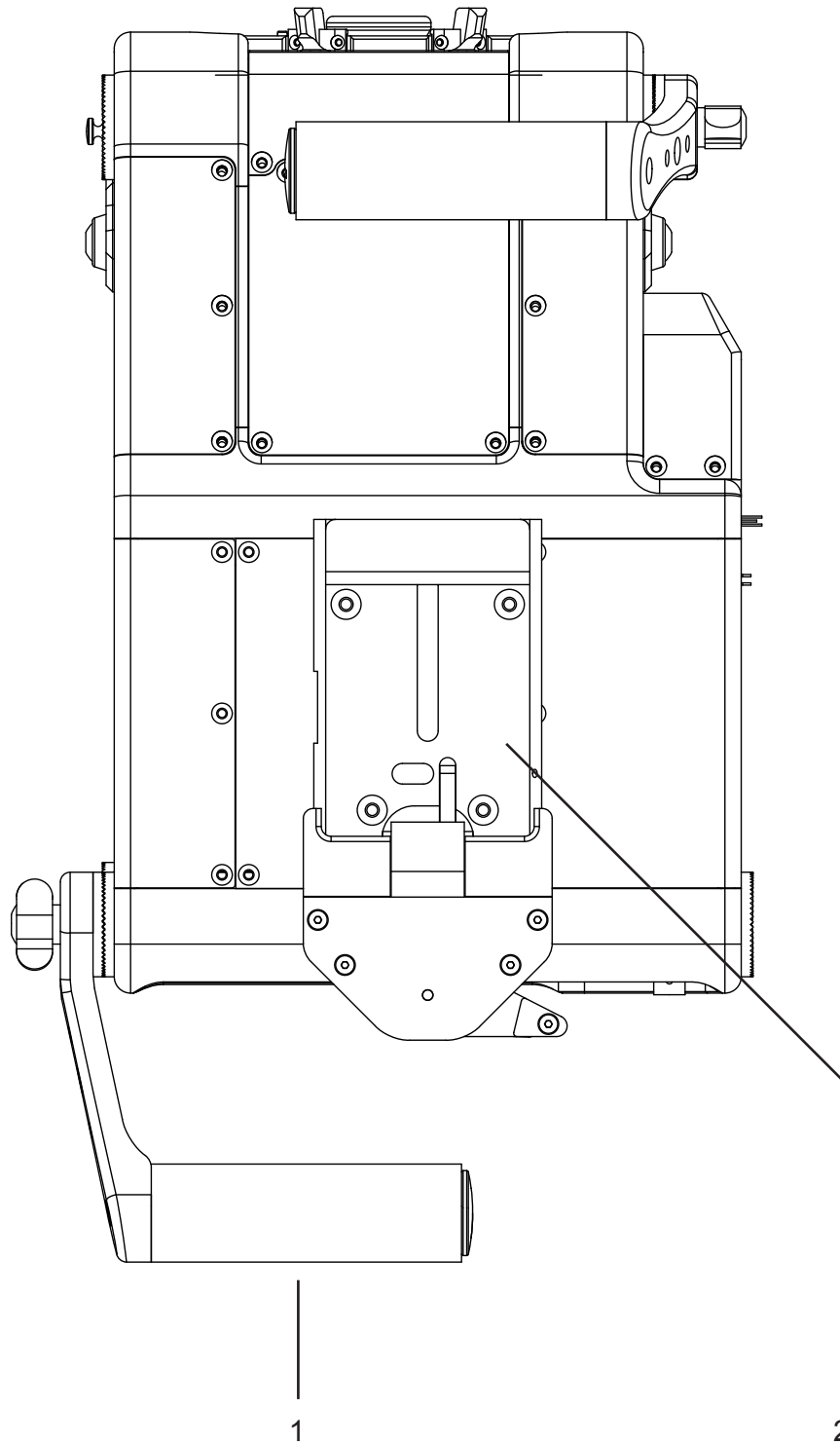

1. Handle

2. Mounting plate for  
WEISSCAM DigiMag DM-2

## 1.3 Connections

- Sync in/out:** These ports enable you to synchronise multiple WEISSCAM HS-2 cameras with pixel accuracy. The master camera (sync generator) is initialised via short-circuiting at the sync in and outputs the sync signal at the sync out. Thus, multiple cameras can be connected in series and all cameras are synchronised via the master camera.
- ACQ EXP:** You can connect devices (accessories) for controlling start/stop signals and changes of speed here. To do so, the camera must be put into recording mode via another operating unit (computer or WEISSCAM Hand Unit HU-2). (will be implemented)
- 12V / 0.5A DC out:** For supplying power to the viewfinder. Lemo 4-pin socket. Only devices with a maximum power of 6 watts may be connected here.
- 12V / 3A DC out:** For supplying power to auxiliary equipment. Lemo 4-pin socket. Only devices with a maximum power of 36 watts may be connected here.
- 24V / 3A DC out:** For supplying power to auxiliary equipment. Fischer 3-pin socket. Only devices with a maximum power of 72 watts may be connected here.
- INT:** Firmware updates can be loaded onto the internal Debayerbox via this USB-B interface. It is also possible to control the internal Debayerbox via software.
- Power switch:** Toggle switch for switching on the camera.  
Downward: Switching on, camera boots up  
Upward: Switching off
- After the camera has booted up correctly, the green "STATUS" LED is illuminated constantly and the camera is ready for operation.
- HEX:** Rotary switch for selecting the 16 presets of the internal Debayerboard (e.g. colour temp, cine curves, focus filter etc.).
- This switch directly impacts the HD-SDI output signal.
- DVI-OUT:** Analogue DVI signal with SVGA 800x600 pixels, for viewfinder (see accessories) or monitor (preview).
- HD-SDI Link A;B:** The WEISSCAM HS-2 is equipped with an internal debayer board, which is used to debayer the RAW data in the 1080p or 720p (RAW) signal of the sensor in real time and convert into a YCbCr 4:2:2 single link or YCbCr 4:2:2 dual stream signal.

For resolutions outside of the HD standard (e.g. 2K with 2048x1536),

# WEISSCAM

## HS-2

you can only operate the camera in RAW mode.

**RAW Link A;B:** In RAW mode, the pure RAW data of the sensor are output via HD-SDI. Here, HD-SDI serves strictly as the transport stream.

**Monitor:** Currently same signal as RAW LINK A.

**Hand Unit:** The WEISSCAM Hand Unit HU-2 is connected to this connector.

**CamINT:** *GigE interface* - The camera can be connected to a PC System using a conventional Ethernet cable via the gigabit Ethernet interface. All functions of the camera can thus be controlled via the WEISSCAM software (basic version).

*USB - B interface*, port for loading camera firmware updates as well as controlling the camera over the WEISSCAM software.

**MASTER/SLAVE:** Intelligent master/slave 24V DC IN changeover circuit. It is intended to eliminate any potential image loss due to an unexpected power failure.

- Connect the main power source (power supply unit) to the DC IN 1 (master).
- Connect the spare battery to the DC IN 2 (slave).

If an unexpected voltage drop should occur at the master input, the device immediately switches to the slave input without impacting camera function. Once there is sufficient voltage at the master input again, the camera automatically switches back to it.

**IMS:** The Interchangeable **M**ount **S**ystem by P+S TECHNIK makes changing camera mounts fast and uncomplicated. When the camera mounts are changed, the flange back is offset by the mounts.

The following mounts are available from P+S TECHNIK:

- *PL-Mount*
- *Panavision-Mount*
- *Professional F-Mount*
- *Nikon F-Mount*
- *Canon EF-Mount*
- *Canon FD-Mount*
- *BNC R-Mount*
- *Contax-Mount*
- *Leica M-Mount*

## 2. Functional description

### 2.1 Setup

#### 2.1.1 Camera Support

**Attaching using a bridge plate:**

Compatible bridge plates are the ARRI BP-5 and BP-8 for Standard35 format.

Position the bridge plate with the screwed-on adapter plate on the bottom of the camera. Allow the parallel pin to engage into the bore provided and fasten the screw so that it is securely tightened. You can now slide the bridge plate onto the dovetail plate.

**Attaching using ARRI or Chrosziel quicklock plates:**

The camera is equipped with an integrated interface for the quicklock plates as used with HD cameras. interface connects well with ARRI and Chrosziel quicklock plates. The Sony VCT-14 is currently not supported.

The interface is located underneath the bridge plate adapter plate screwed onto the bottom of the camera. Unscrew the adapter plate. Then position the camera on the guide rails of the quicklock plate and slide it forwards until the safety lever can be engaged. Check that the camera is firmly and securely attached.

**Tripod head:**

Due to the weight of the camera, use tripod heads with a diameter of 150 mm only.

Examples of suitable tripod heads:

- ARRIHEAD (C)
- ARRI Fluid Heads
- Sachtler 150H
- O'Connor 2575

**Attaching handles / accessories:**

Both camera sides have rosettes, which can be used to attach the handle system provided as well as additional accessories. ¼ inch screws are used for fastening the devices.

## 2.1.2 Wiring

### Power supply unit / battery

Connect the power supply unit provided to the "MASTER DC IN 1" of the camera via the 4-pin XLR / 2-pin Fischer cable.

To protect against image loss during a power failure or due to pulling the power plug accidentally, a charged battery should be connected to the "SLAVE DC IN 2".

This battery that is connected to the "SLAVE DC IN 2" will neither be discharged nor run empty while the camera is properly operated via "MASTER DC IN 1".

Only when the power supply from "MASTER DC IN 1" falls below 22V will the camera switch to "SLAVE" within 5 ms, and the battery will be used to supply power.

Of course, you can also work with one or two batteries instead of the power supply unit.



The permitted voltage range of the camera is between 18V and 30V DC ! Fully charged 30VDC batteries have voltages of up to 36V and can thus damage the camera. Please only use 24VDC batteries.

### Hand Unit HU-2 (*stand alone version*)

#### *Cabled operation*

Connect the Hand Unit cable (#19917; 0,6m) provided (7-pin Fischer connector) to "CBUS" on the HAND UNIT and to "HAND UNIT" on the camera side.

This cable is used for communication with the camera and to supply power to the Hand Unit HU-2. An alternative cable is the article #19851 which is a 6 m long cable.

#### *Wireless operation*



For wireless operation, the CAMIN interface including 16-pin C-Motion cable is required, the proper firmware for communication with the WEISSCAM HS-2 must be installed, and the radio channels between the CAMIN and Hand Unit HU-2 must be synchronised.

Connect the RWC-1 cable belonging to the CAMIN (16-pin Fischer connector) to "EXT" on CAMIN and to "HAND UNIT" (7-pin Fischer connector) on the camera side.

In wireless mode, the Hand Unit HU-2 must be powered via a battery that is attached to the rear side of the Hand Unit HU-2.

To do so, position the battery on the guide groove and slide it upwards until it engages. In order to detach and remove the battery, press in the lock button on the bottom of the Hand Unit HU-2 and remove the battery by pulling it downwards.



## PC system via Gig-E or USB (*basic version*)

The camera can also be controlled with the WEISSCAMware via a PC System instead of the Hand Unit HU-2. The prerequisite for camera operation via PC System is an *NVIDIA* graphics card (Minimum: 8000 series). The camera must be connected to the PC System via a Gigabit Ethernet or USB cable. Please note that Gigabit Ethernet delivers a higher data rate. For this purpose, plug the cable into the INT input on the rear side of the camera and connect it to a free PC System port.

## WEISSCAM DigiMag DM-2

For single link data transfer, connect a BNC cable (75 ohms) to "HD-SDI LINK A" (for HD-Stream) or "RAW LINK A" (for RAW-Stream) on the camera side and the BNC signal input on the recorder side.

For dual link (and dual stream) data transfer, connect one BNC cable (75 ohms) each to HD-SDI LINK A & B on the camera side. Connect the respective BNC cables on the recorder side to the compatible HD-SDI inputs.



For dual link data transfer, be absolutely certain that the cables have the same length and identical cable grade.

## Viewfinder

The electronic viewfinder (included in stand alone version) should be powered via the 12V connection of the camera.

Connection on the rear side of the camera: "12V (0.5A) DC OUT" (4-pin Fischer)

In order to receive a video signal on the viewfinder, the VGA port of the viewfinder must be adapted to DVI. Connect the adapted cable to the "DVI OUT" output of the camera.

The viewfinder should be attached to one of the rosettes.

## Additional monitors

A video signal can be fed to additional control and preview monitors in single link mode via the HD-SDI LINK B (BNC).

When the WEISSCAM DIGIMAG DM-2 is used, the HD-SDI signal can be looped through the recorder and tapped at the RAW/HD-SDI OUT LINK A and/or LINK B.

"MONITOR OUT" of the camera is currently still identical to RAW Link A.

An onboard monitor can be powered by the internal camera power source. A max. 12V 3A output is available for this purpose.

# WEISSCAM

## HS-2

## 2.2 Operation

### 2.2.1 Starting the Camera

Since the WEISSCAM HS-2 is shipped in various configurations, two modes must be distinguished: the stand alone and the basic version. Both are explained separately in the sections below.

In the "*stand alone*" version, the WEISSCAM HS-2 is controlled completely via the *WEISSCAM Hand Unit HU-2*. Thus, no PC system connection is necessary.

All settings of the Hand Unit HU-2 are configured via the touchscreen display and control wheel. Important commands such as RECORD, STOP and PLAY can also be selected via hardware buttons.

In the "*basic version*", the WEISSCAM HS-2 is controlled via a PC system. All necessary settings are configured via the WEISSCAM Software. The software must be installed on a computer that has an NVIDIA graphics card (minimum 8000er series).

#### Camera (ON/OFF switch / LEDs)

To switch on the camera, actuate the ON/OFF switch on the rear side of the camera.

If the camera is supplied with power correctly, you will instantly hear the camera's ventilation starting up and the camera system will boot up. After approx. five seconds a test image is displayed and the camera is ready.

The LEDs on the rear side indicate the status of the camera.

- STATUS: Is illuminated in green: Camera is ready
- REC: Is illuminated in blue: Recording
- Error: Is illuminated in red: An error has occurred. Restart the camera.

# WEISSCAM HS-2

## Hand Unit HU-2 (for stand alone version)

To switch on the WEISSCAM Hand Unit HU-2, hold the blue ON/OFF button on the left side pressed for one second.

If everything is wired properly and supplied with power, the Hand Unit HU-2 boots up and the WEISSCAM Software is started and automatically detects the camera.

The WEISSCAM HS-2 logotype appears in the window frame on the right side next to CamType.

If "No Camera", is displayed instead of "WEISSCAM HS-2", there is no connection and the camera cannot be controlled.

For potential causes and solutions, refer to the "Troubleshooting" chapter.

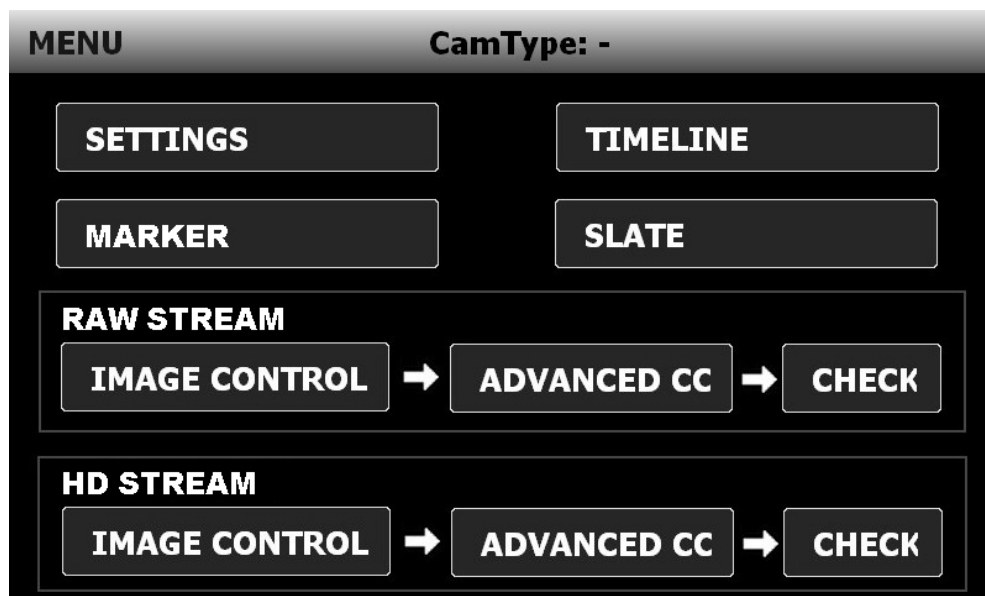

## **Software (for basic - IT-based version)**

Start the WEISSCAMware software. Several seconds may pass until the software has started up completely.

If the camera has been detected, the message "Camera type: WEISSCAM HS-2" appears in the upper part of the SETTINGS window.

If the message "No camera found" is displayed, the camera has not been detected.

For potential causes and solutions, refer to the "Troubleshooting" chapter.

*-Screenshot!-*

### 2.2.2 Recording Settings

#### Initial settings

Several settings have to be configured before a recording can begin. These include the selection of the recording format, the frame rate (fps) and the corresponding shutter speed.

#### A) - Stand alone version

1. On the Hand Unit HU-2, select the "SETTINGS" field/button in the main menu to access its submenu.
2. Pressing the "Format" line opens a window containing a selection of recording formats. Once a format is selected, it is applied and the window closes automatically.
3. Pressing the "Rec.speed" line opens a window containing a selection of values representing frame rates. Once a speed is selected, it is applied and the window closes automatically. (You can specify your own number using the "Custom" option.)
4. Pressing the "Shutter" line opens a window containing a selection of shutter speeds. Once a speed is selected, it is applied and the window closes automatically. (You can specify your own number using the "Custom" option.)



*Note: The largest available shutter speed always corresponds to the currently configured frame rate. Of course smaller shutter speed values can also be selected.*

5. Pressing the "Rec.mode" line opens a window containing two different "record modes": Ring Buffer and Sequence. Once a mode is selected, it is applied and the window closes automatically.
6. When working in "FAST RAW MODE SL" the sub menu "Output" offers signal adjustment options for the HD-SDI LINK A and LINK B outputs:  
*1080 50i (single link)* - offers an identical output of a 50i signal on LINK A and B  
*1080 50p (dual stream)* - generates a 50p signal split between LINK A and B (50i stream each). Two BNC cables are necessary to setup this connection between camera and the particular recorder. The recorder must support 50p Dual Stream as well as must be setup for this incoming signal.

The most important settings have now been configured under the SETTINGS menu.

These basic settings are sufficient for beginning a recording as described in the following step.

7. Select "CLOSE" at the upper right to return to the main menu. All settings are saved automatically until changed or until the camera is switched off.

## B) Basic - IT-based version

Detailed instructions for all functions and setting options of the WEISSCAM software are provided in the WEISSCAMware manual. This manual provides only one possible workflow.

1. Check that the software has started correctly and the camera has been detected.
2. In the "SETTINGS" window of the application, select the desired format, frame rate and shutter speed by clicking the corresponding buttons.  
Always confirm all inputs and settings by selecting OK, as they are not applied otherwise.  
*Tip: If the Format, FPS and Shutter buttons are disabled, check whether the camera is presently in REC mode. If this is the case, stop recording and then make your changes.*
3. All settings have been applied correctly if their values appear as intended behind their corresponding items in the "SETTINGS" window.

### Selecting the record mode

Because the quantity of data acquired at high frame rates is large, the recording is not sent directly to a recorder, but instead is buffered in the camera's internal RAM.

The record mode determines how the image data are written to the camera's RAM memory.

Various modes are available for different functions.

**Sequence mode:** Once recording has started, data is written once to RAM until it is full, and then the recording is stopped automatically.

*Example: Possible recording length to RAM: 12 seconds*

*12 seconds after being started, the recording stops automatically.*

**Ring Buffer mode:** Once recording has started, RAM is continuously written to until the recording is stopped manually.

Image data that go beyond the possible RAM recording length are overwritten by new image data.

*Example: Possible recording length to RAM: 12 seconds*

*Once started, recording continues until it is stopped manually.*

*The last 12 seconds of the recording time are saved.*

**Centre Trigger:** This is a combination of the Sequence and Ring Buffer modes.

When recording is stopped, the camera continues to record for half of the possible recording duration before actually stopping.

*Example: Possible recording length to RAM: 12 seconds*

*After being stopped manually, recording continues for 6 seconds.*

*The recording data that remains in RAM includes the 6 seconds prior and the 6 seconds after recording has been stopped.*

# WEISSCAM

## HS-2

*Additional mode in the IT-based software:*

After Trigger:            Similar to Centre Trigger, but with a manually configurable centre point.

Ramping:                 Here it is possible to jump between two different frame rates (fps) during the recording.

### *A) Stand alone version*

1. On the Hand Unit HU-2, select the "SETTINGS" field/button in the main menu to access its submenu.
2. Select the "REC. Mode" line to open a selection window in the lower section of the "SETTINGS" menu. Click the desired mode here to select it.  
Once a mode is selected, it is applied and the window closes automatically.
3. Select "CLOSE" at the upper right to return to the main menu. The new configuration is saved automatically until changed or until the camera is switched off.

### *B) Basic - IT-based version*

1. If recording is in progress, stop it.  
(Click the "STOP" button in the "Timeline" window.)
2. In the "SETTINGS" window of the application, select the desired record mode by clicking it.
3. These settings do not have to be confirmed separately; they are applied as soon as selected.



## Adjusting white balance for HD-SDI stream (output)

White balancing can be accomplished more quickly using the Hand Unit HU-2 and WEISS-CAMware. This requires that the camera be in record mode/Live Image mode.

The white balance adjustment is carried out on a white surface which must fill at least 60 percent of the image area. The luminance of the white should be 50 percent.

### A) Stand alone version

1. Switch the camera to REC./Live Image mode: On the Hand Unit HU-2, select the "TIMELINE" field/button in the main menu to access its submenu.
2. Switch the camera to record mode by pushing the red record field/button.
3. Select "CLOSE" at the upper right to return to the main menu. The recording/Live Image continues to run.
4. Select the "IMAGE CONTROL" field/button in the main menu to access its submenu.
5. Make sure that sufficient white is within the image area.  
Push the field/button "Auto White" once. The white balance adjustment takes place automatically, and the results appear in the image immediately.
6. Select "CLOSE" at the upper right to return to the main menu. The balance is saved automatically until changed or until the camera is switched off.  
(Note: The camera is still in operation.)
7. Record/Live Image mode can be stopped at any time from the "TIMELINE" menu.

### B) Basic - IT-based version

1. Switch the camera to REC./Live Image mode. -> In the WEISSCAMware "Timeline" window, click the red record button.
2. Make sure that sufficient white is within the image area.  
Click the field/button "Auto white". The white balance adjustment takes place automatically, and the results appear in the image immediately.  
*Tip: Alternatively, the white balance can be adjusted manually by modifying the RGB values. These values can be stored using "Save LUT".*
3. Note: The camera is still running – you can continue work immediately if desired.

### Starting a recording

By using "Ring Buffer" mode, it is possible to keep the camera recording continuously, and to adjust the "Live Image" as needed. Changes to the Image Control via the Hand Unit HU-2 or the HEX switch can be tested directly

#### A) Stand alone version

1. Check that all preconfigured settings are correct. (Format, frame rate, shutter speed, REC. mode)
2. In the main menu of the Hand Unit HU-2, touch the "TIMELINE" field/button to open its sub-menu.
3. Start recording by pressing either the red record field/button on the display, or the red record hardware button.

Recording begins.

*Tip: Four features indicate that recording has begun:*

1. The white line of the timeline extends towards the right, thus indicating the progress of the recording.
  - In Sequence mode, the recording is stopped automatically at the end.
  - In Ring Buffer mode, the recording continues until manually stopped.
2. The frame counter (image) counts the recorded frames up to the maximum capacity of the RAM, "Rec" is shown in the info box.
3. A live image is displayed.
4. The red dot in the status line blinks while recording until the recording is stopped.

#### B) Basic - IT-based version

1. Check that all preconfigured settings are correct. (Format, frame rate, shutter speed, REC. mode)
2. In the timeline window, start recording by clicking the red record button (or by pressing the "R" shortcut).
3. Recording begins. (Timeline progress, red flashing in timecode, frame counter counts.)



The recording length based on the internal camera RAM depends on various factors. Depending on the size of the RAM, the format and the frame rate, the following recording durations are possible:

## WEISSCAM HS-2 with 16GB RAM

	25 fps	50	100	150	250	350	500	1000	1500	2000
2016 x 1556	02:44	01:22	00:41	00:27	00:16	00:11	00:08	00:04	00:02	-
1920 x 1080	04:08	02:04	01:02	00:41	00:24	00:17	00:12	00:06	00:04	00:03
1280 x 720	09:19	04:39	02:19	01:33	00:55	00:39	00:27	00:13	00:09	00:06
1024 x 576	14:33	07:16	03:38	02:25	01:27	01:02	00:43	00:21	00:14	00:10

Time specified in minutes and seconds

## WEISSCAM HS-2 with 32GB RAM

	25 fps	50	100	150	250	350	500	1000	1500	2000
2016 x 1556	05:28	02:44	01:22	00:54	00:32	00:23	00:16	00:08	00:05	-
1920 x 1080	08:17	04:08	02:04	01:22	00:49	00:35	00:24	00:12	00:08	00:06
1280 x 720	18:38	09:19	04:39	03:06	01:51	01:19	00:55	00:27	00:18	00:13
1024 x 576	29:07	14:33	07:16	04:51	02:54	02:04	01:27	00:43	00:29	00:21

Time specified in minutes and seconds

### **Stopping recording and starting playback**

Depending on the REC. modes, the recording must be stopped manually or stops by itself. In the recommended "Ring Buffer" mode, the recording should be stopped manually immediately after the action.

#### *A) Stand alone version*

1. If you have not done so already, switch to the "TIMELINE" menu of the Hand Unit HU-2.  
(In the main menu by pressing the "TIMELINE" field/button)
2. Stop the recording by pressing the Stop field/button in the display or the white Stop Hard button.  
The camera is now ready to play back the last recording.
3. You can start the playback immediately by pressing the Play field/button.
  - To limit the range for playback, set "Cut In" and "Cut Out" markers.
  - In order to jump to the markers just move the cursor to the white arrows over or below the timeline.
  - By pressing "Loop Marker", you can start a loop playback between the markers.
  - Press "Delete Marker" to remove the markers.

#### *B) Basic - IT-based version*

1. Stop the recording by clicking the Stop button (or the "Enter" shortcut).  
The camera is now ready to play back the last recording.
2. You can start the playback immediately by clicking the Play button.
  - To limit the range for playback, stop playback and set markers using "Cut In" and "Cut Out".
  - In order to remove the markers press short cut "M" to select a pair of markers. Now press "Delete marker" remove them.

## 2.2.3 Download Settings

### Copying a sequence to a recorder

In the stand alone version of the WEISSCAM HS-2, the data in RAM are transferred to a hard disk, flash or tape recorder via single or dual link.

In the Basic IT-based version, data can be transferred to a PC systems in various file formats (TIFF, DPX, RAW) via gigabit Ethernet or USB.

#### A) Stand alone version

1. Ensure that the cable (single/dual link) between the camera and recorder are connected properly.
2. Check that the desired range of the sequence is enclosed (marked) between the two markers.
3. When copying HD data (YCbCr 4:2:2), use the HEX switch on the camera to select the desired debayer algorithm (look), or chose by loading a HEX file frm the Hand Unit HU-2.
4. On the Hand Unit HU-2, press the "Save Marker" field/button.  
The transfer of the selected range begins.
5. On the recorder, start the recording manually. (Note that the WEISSCAM DigiMag has a two-second delay after you press the RECORD button before it starts recording. For this reason, adjust the "In point" of the sequence to be copied accordingly.)
6. After the end of the selected range has been reached, the transfer stops automatically.
7. On the recorder, stop the recording manually.

#### B) Basic - IT-based version

*For transfer to a PC system via gigabit Ethernet or USB:*

1. Ensure that the cable (gigabit Ethernet or USB) between the camera and PC system is connected properly.
2. Check that the desired range of the sequence is enclosed (marked) between the two markers.
3. Before transferring the data, specify the path, filename and take number under "File Management" in the Settings window. In addition, the file format to be written and the algorithm to be used must be selected.
4. To start the data transfer, click the "Save Marker" button in the "Timeline" window.  
When the download starts, an information window appears showing the progress.  
When the transfer is complete, the information window closes and the camera is ready for the next recording.

## 2.2.4 WEISSCAM Format Overview

The WEISSCAM HS-2 stand alone camera can output simultaneously an HD- and a RAW stream through HD-SDI connection.

### WEISSCAM HD Data Transfer

*1:1 mode ("STANDARD RAW MODE SL")*

**HD OUT:** Standard transfer (single link)

- 1080 24psf - on LINK A and LINK B identical signal output
- 1080 25psf - on LINK A und LINK B identical signal output
- 1080 30psf - on LINK A und LINK B identical signal output

*2:1 mode ("FAST RAW MODE SL")*

**HD OUT:**

Transfer in higher data rate (single link at 50i or dual stream at 50p)

- 1080 50i - on LINK A and LINK B identical signal output (YCbCr 4:2:2).  
Each recorded full frame is converted into a half image. The actual playback speed is doubled that way.
- 1080 50p - on dual stream; camera and recorder must be connected on LINK A and LINK B with two cables of same length and grade.  
Each cable transfers "one half" of the image as a 50i signal. The two 50i stream together form the 50p image. The respective recorder must be capable of dual stream recording.



*Attention:*

*In this mode RAW 50p is connected with single link, HD with dual stream.*

To receive the signal on the HD output of the camera, choose the appropriate setting (*50i single link* or *50p dual stream*) in the Hand Unit HU-2 in the "SETTINGS" window behind "Output"

.fghDP/DI	YCbCr 4:2:2 10-bit 1920 x 1080 p/i	6.528 Kb	Single link
.fghMP	YCbCr 4:2:2 10-bit 1920 x 1080 p HighSpeed	12.288 Kb	Dual link

## WEISSCAM RAW Data Transfer



The WEISSCAM HS-2 transports its RAW signal within the HD-SDI stream. To increase the transfer speed, two different modes are possible.

*1:1 mode (“STANDARD RAW MODE SL”):*

**RAW OUT:** One RAW frame is transferred for each HD-SDI frame through single link connection

- RAW 24p - on LINK A and LINK B identical signal output with playback speed of 24fps
- RAW 25p - on LINK A and LINK B identical signal output with playback speed of 25fps
- RAW 30p - on LINK A and LINK B identical signal output with playback speed of 30fps

The WEISSCAM DigiMag DM-2 must be set on “WEISSCAM STANDARD RAW “ in the input menu.



- Data that are copied to the WEISSCAM DigiMag DM-2 in 1:1 mode of the camera are also visible 1:1 after transfer to a PC system.

*Example: If 100 frames are transferred, 100 files are displayed in the folder.*

*2:1 mode (FAST RAW MODE SL):*

**RAW OUT:** Two RAW frames are transferred for each HD-SDI frame through single link or dual link only for 100p, 120p and 2K

- RAW 50p - on LINK A and LINK B identical signal output with playback speed of 50fps

The WEISSCAM DigiMag DM-2 detects the mode and stores two RAW frames in each file if the WEISSCAM DigiMag DM-2 is set to “WEISSCAM FAST RAW“ in the input menu.



- Data that are copied to the WEISSCAM DigiMag DM-2 in the fast 2:1 mode of the camera are also only visible 2:1 after transfer.

*Example: If 100 frames are transferred, only 50 files are displayed in the folder. There are now two frames in each individual file, which are again displayed 1:1 after conversion.*

.fghWA	WEISSCAM RAW 720 50p - STANDARD RAW	3.312 Kb	Single link
.fghWB	WEISSCAM RAW 720 50i/p - FAST RAW	3.312 Kb	Single link
.fghWC	WEISSCAM RAW 1080 23.98p/24p/25p/29.97p/30p/ - STANDARD RAW	6.528 Kb	Single link
.fghWD	WEISSCAM RAW 1080 50p / 60p - FAST RAW	6.528 Kb	Single link
.fghWE	WEISSCAM RAW 1080 100p / 120p - FAST RAW	12.288 Kb	Dual link
.fghWF	WEISSCAM RAW 2048 25p - STANDARD RAW	6.528 Kb	Single link
.fghWG	WEISSCAM RAW 2048 50p - STANDARD RAW	12.288 Kb	Dual link

## 2.2.5 Further Processing the RAW/HD Material

### Workflow for RAW

#### *Output via HD-SDI - WEISSCAM DigiMag*

RAW data can be output directly to a capture station through a "WEISSCAM Debayerbox DBB-2" via HD-SDI. The RAW stream is converted to an HD stream (YCbCr 4:2:2) live and without delay. The material can then be further processed as usual.

#### *Output via IT interfaces - WEISSCAM DigiMAG*

The RAW material recorded on the WEISSCAM DigiMag can be transferred to a PC system via IT interface. (FireWire or Fibre Channel). The takes are displayed in folders, the individual frames in files.

The following options exist for opening the RAW files, debayering them and converting them into a desired format:

1. Using the WEISSCAM software: RAW files (\*.wcr) can be opened, debayered and converted into various formats using batch rendering.  
IMPORTANT: At the moment only RAW files created by WEISSCAMware can be badge-rendered, no RAW files copied from DigiMag DM-2 (\*.fhgWD). This is planned for the next update.
2. Using software products from IRIDAS.
  - Framecyclor Pro:
    - Full-quality RAW playback for mobile use,
    - Quality control incl. waveform and histogram
    - Primary grading tools to check levels (gamma, gain, offset for preview purposes)
  - Speedgrade XR and DI:
    - Full-quality real-time RAW for dailies and for final grading
    - Quality control incl. waveform and histogram
    - Batch rendering
    - Full-blown grading feature set incl. effects such as Bleach Bypass, Technicolor 2-Strip, 3-Strip



## Quick start guides:

The following sections are intended merely as quick start guides for the respective programs. For detailed explanations, refer to the corresponding manuals.

### *WEISSCAM Software for HS-2*

**IMPORTANT:** At the moment only RAW files created by WEISSCAMware can be badge-rendered, no RAW files copied from DigiMag DM-2 (\*.fhgWD). This is planned for the next update.

1. Start the WEISSCAMware software (camera must be offline)
2. Load the sequence: In the Settings window, click the "Calibrate/Load Sequence" button to select the desired sequence. Here, it is sufficient to select a frame of the desired sequence, as the latter is detected by the WEISSCAMware automatically. Then, click the "Loaded" button to load the sequence into the timeline.
3. Carry out the colour correction: Configure the desired values at the left in the Image Control window using the faders for RGB, saturation, offset etc.
4. Save the LUT (Look up Table) for these settings via "Save LUT".
5. Repeat steps 2 - 4 if you want different looks for different material.
6. Close the WEISSCAMware software (select "Yes" to confirm the safety warning that appears). Start WEISSCAM Batch Generator.
7. Using the "Add Batch Job/Take" button, load selected takes into the take field. In doing so, it is sufficient to select a frame of the sequence, as the latter is detected automatically.
8. You can display the respective settings by clicking the individual takes.
9. If you want to change the target folder, you can do so using "Change Target".
10. The target format can then be set in the "Target Format" line via the drop-down menu. If you want to render all takes of the take list to the same format, you can configure this by clicking "Use Selected for All".
11. To select a new In point or Out point, you have to enable the tick mark behind "Use New Cut In/Out". Then, enter the new values after "New Cut In Position" and "New Cut Out Position".
12. For the type of debayering, you can now load the LUT created previously. To do so, click "Select LUT" in the "CC.:" line and select the corresponding file. Via "Use Original", you can also use the original settings of the file for rendering.
13. Now click "Generate Batch File" to generate the corresponding batch file.
14. Close the batch generator and open WEISSCAMware.
15. Load the batch render file. In the Settings window, click the "Calibrate/Load Sequence" button and load the corresponding file.
16. Confirm the message with OK to start the rendering. A window with the status display of the rendering process should open.
17. After the rendering process is finished, you can close the WEISSCAMware software (select "Yes" to confirm the safety warning that appears).

### *IRIDAS Framecyclor Pro (2009 or higher)*

1. Start the software.
2. Search for the sequence. If necessary, click "Desktop" at the bottom left to show the folder structure. (The selection is selected or deselected using "Desktop".)
3. Select the folder. The files in it are displayed on the right as thumbnails.
4. Select the sequence. Hover the cursor over a thumbnail, then click the plus symbol that appears and load the sequence into the timeline. Click "Desktop" again to close the desktop selection.
5. Colour correction/grading. Click "Global Grading" (located above the timeline on the right) to open the Grading Tool window.  
Adjust the contrast, brightness, hue and offset as desired using the various faders.
6. Render. Click the "Render" button at the bottom centre to call up the Render window.  
(You can use it to select or deselect the Render window.)
7. Configure settings. In the Render window, use the tabs and the corresponding drop-down menus to select the desired format.
8. Specify the path and file name. Single-clicking "Render" in the Render window opens a window with the file structure. Here, specify the path and the desired filename.
9. Start rendering. To do so, click "Render" at the bottom right in the Render window with the file structure.

### *IRIDAS SpeedGrade (2009)*

1. Start the software.
2. Search for the sequence. If necessary, click "Desktop" at the bottom left to show the folder structure. (The selection is selected or deselected using "Desktop".)
3. Select the folder. The files in it are displayed on the right as thumbnails.
4. Load the sequence. Hover the cursor over a thumbnail, then click the plus symbol that appears and load the sequence into the timeline. Click "Desktop" again to close the desktop selection.
5. Colour correction/grading. Click "Global Grading" (located above the timeline on the right) to open the Grading Tool window.  
Adjust the contrast, brightness, hue, offset etc. as desired using the various faders.  
You can make more in-depth image adjustments using the "Highlights", "Midtones" and "Shadows" buttons on the left side and the "Secondaries" and "Mask" buttons on the right side of the sub-menus.
6. Render. Single-click "Render" to open the rendering mask.  
The "Render" button is at the bottom centre; you can use it to select or deselect the rendering mask.
7. Path and file name. In the rendering mask, enter the path and file name under "Destination".
8. File format. Under the "Format" menu item, you can select a default format using the drop-down menu or create your own by clicking "Other...". Select the desired settings using the "Options" menu item.
9. Render. To start the conversion, click the "Render" button under the "Render" menu item.

## Workflow for HD

### *Output via HD-SDI - WEISSCAM DigiMag or other recorders*

The HD material recorded on the WEISSCAM DigiMAG can be exported via the HD-SDI interface to any capture station that is compatible with the YCbCr 4:2:2 signal.

From there, the material can be further processed as usual.

### *Output via IT interfaces - WEISSCAM DigiMAG*

The HD material recorded on the WEISSCAM DigiMag can also be transferred to a PC system via IT interfaces (FireWire; Fibre Channel).

The material is then stored in a proprietary file format in individual folders, which are each named according to their takes.

To open these files, colour-correct them if necessary and convert them into a desired file and video format, we recommend using software products (2009 or higher) from IRIDAS.

### **Quick start guide for converting the file format:**

#### *IRIDAS Framecycler Pro (2009)*

1. Start the software.
2. Search for the sequence. If necessary, click "Desktop" at the bottom left to show the folder structure. (The selection is selected or deselected using "Desktop".)
3. Select the folder. The files in it are displayed on the right as thumbnails.
4. Select the sequence. Hover the cursor over a thumbnail, then click the plus symbol that appears and load the sequence into the timeline. Click "Desktop" again to close the desktop selection.
5. Colour correction/grading. Click "Global Grading" (located above the timeline on the right) to open the Grading Tool window.  
Adjust the contrast, brightness, hue and offset as desired using the various faders.
6. Render. Click the "Render" button at the bottom centre to call up the Render window. (You can use it to select or deselect the Render window.)
7. Configure settings. In the Render window, use the tabs and the corresponding drop-down menus to select the desired format.
8. Path and file name. Single-clicking "Render" in the Render window opens a window with the file structure. Here, specify the path and the desired filename.
9. Start rendering. To do so, click "Render" at the bottom right in the Render window with the file structure.

### *IRIDAS SpeedGrade (2009)*

1. Start the software.
2. Search for the sequence. If necessary, click "Desktop" at the bottom left to show the folder structure. (The selection is selected or deselected using "Desktop".)
3. Select the folder. The files in it are displayed on the right as thumbnails.
4. Load the sequence. Hover the cursor over a thumbnail, then click the plus symbol that appears and load the sequence into the timeline. Click "Desktop" again to close the desktop selection.
5. Colour correction/grading. Click "Global Grading" (located above the timeline on the right) to open the Grading Tool window.  
Adjust the contrast, brightness, hue, offset etc. as desired using the various faders.  
You can make more in-depth image adjustments using the "Highlights", "Midtones" and "Shadows" buttons on the left side and the "Secondaries" and "Mask" buttons on the right side of the submenus.
6. Render. Single-click "Render" to open the rendering mask.  
The "Render" button is at the bottom centre; you can use it to select or deselect the rendering mask.
7. Path and file name. In the rendering mask, enter the path and file name under "Destination".
8. File format. Under the "Format" menu item, you can select a default format using the drop-down menu or create your own by clicking "Other...". Select the desired settings using the "Options" menu item.
9. Render. To start the conversion, click the "Render" button under the "Render" menu item.

## Deciding on HD-SDI or RAW

Deciding whether HD-SDI or RAW streams will be recorded over depends on a number of factors. The respective advantages and disadvantages of the formats and, above all, of the desired/possible workflow in post-production must be taken into consideration.

The following additional information on WEISSCAM HS-2 RAW and HD-SDI streams can help.

### WEISSCAM RAW:

*Advantage:* Image material is 12-bit uncompressed, a good starting point for post-production. Faster downloading/mode of working.

*Disadvantage:* Image material must still be debayered / colour-corrected – time-consuming.

### HD-SDI STREAM:

*Advantage:* Debayering is no longer necessary, direct copy to and print-to-tape possible; signal accepted by most recorders.

*Disadvantage:* Two bits of information less than in the RAW material; later corrections in post-production are not as in-depth.

## 2.3 Updating the Firmware

### 2.3.1 Updating the Debayerboard Inside the Camera

When new software releases are distributed, the internal debayerboard can be updated using a PC or laptop and an USB cable.

1. The switched-off camera must be connected with the PC. There is a USB-B cable for doing this. On the right camera side, plug it into INT; on the PC system, plug it into an available USB port.
2. Open the update file "DBB.UPD.exe".
3. In the COM 2 field, specify the corresponding communication port, e.g. COM2, COM3, etc.

To start, press the "Update firmware" button.

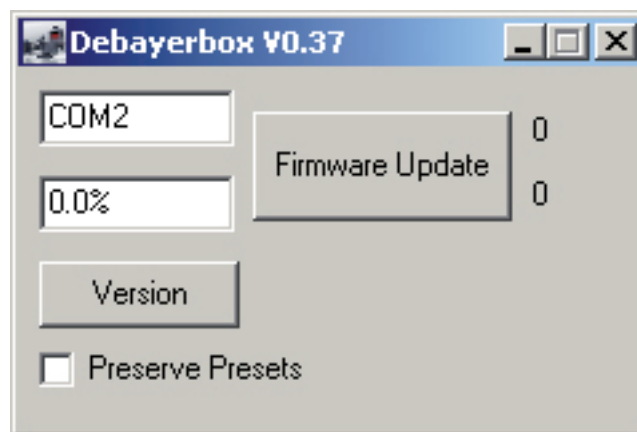

If there is an error message, verify that the communication port (COM) has been entered correctly.

4. Press the "OK" button and then start the camera.

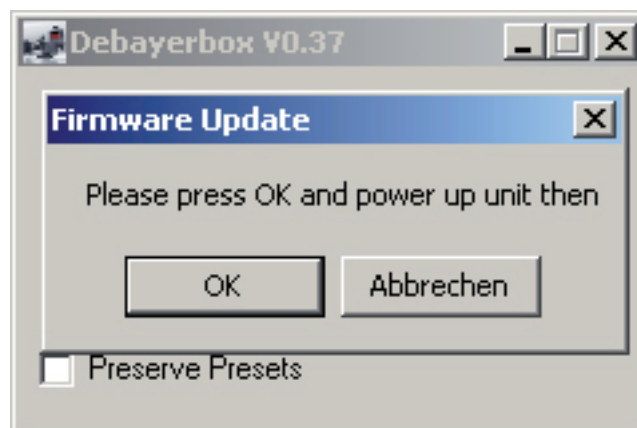

The update process is carried out (the current installation status is displayed as a progressive percentage).

5. After the update process is finished, restart the camera.

The current firmware update is active after the restart. The settings stored on the HEX switch must be recreated.

## 2.3.2 Updating the Camera Firmware

Coming soon.

## 2.4 Miscellaneous

### 2.4.1 Possible Recorders

In order to record the HD-SDI stream, the recorder must satisfy the respective SMPTE standard and, where applicable, the correct format must be configured on the recorder. To record the RAW stream, the recorder must be specified for this signal.

*Possible recorders: HD-SDI single + dual link*

- WEISSCAM DIGIMAG-2 (DM-2)
- Sony SRW-1 (dual stream mode)
- Sony SRW - 5800 with 4:4:4 RGB board (dual stream mode)
- DVS Clipster
- EVS
- Capture cards with dual stream function

*Possible recorders: HD-SDI single link*

- WEISSCAM DIGIMAG-2 (DM-2)
- All recorders & capture cards that can process 1080 50i

*Possible recorders: RAW*

- WEISSCAM DIGIMAG (DM-2)



## 2.4.2 Viewfinder (electronic) - Instructions

### User interface options

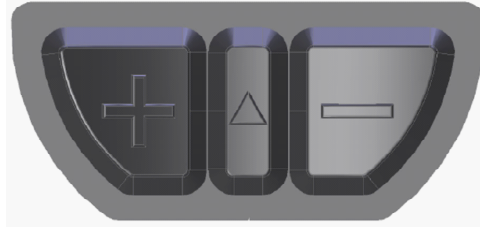

Plus    Mode    Minus

### Quick Setup:

1. Plug an VGA video source (DVI Output at WEISSCAM HS-2 with DVI to VGA Adapter) into the video input connector.
2. Go to the Video Input Operation, Display Orientation Operation, Color Calibration Operation, Reset Operation, or apply power.
3. The user will notice that red/green/blue lights blink inside the display twice at power up.
4. The display defaults to luminance control and SVGA input ready at power up.
5. Go to Normal Operation sequence.

## Video Input Operation

1. Before power up, press and hold the Plus and Mode button simultaneously and then apply power to change video input modes.
2. Release the Plus and Mode buttons and the display will toggle input modes (SVGA to VGA, or vice versa).
3. After two seconds, the white light will blink once to indicate the memory being set with the current settings.
4. Go to Normal Operation.

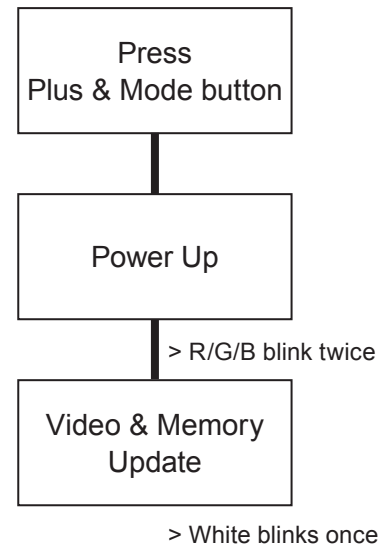

## Display Orientation Operation

1. Before power up, press and hold the Mode button and then apply power to change video input orientation.
2. Release the Mode button and the display will rotate 180 degrees.
3. After two seconds, the white light will blink once to indicate the memory being set with the current settings.
4. Go to Normal Operation.

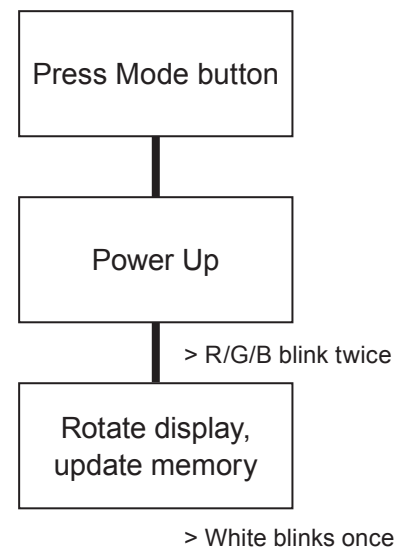

## Color Calibration Operation

1. Before power up, press and hold the Plus and Minus buttons simultaneously and then apply power to enter color calibration mode. The buttons must be released to enter the mode.
2. After the display illuminates, the red, green, and blue colors of the display can be adjusted. The display defaults to red brightness control.
3. Press once or press and hold the Plus button to increase red brightness. Press once or press and hold the Minus button to decrease red brightness. While either button is pressed, the red light will be lit. If the display is increased or decreased to maximum or minimum luminance, respectively, the red light will blink quickly.
4. Press the Mode button for one second to change from red brightness mode to green brightness mode. The green light will blink twice indicating the mode change.

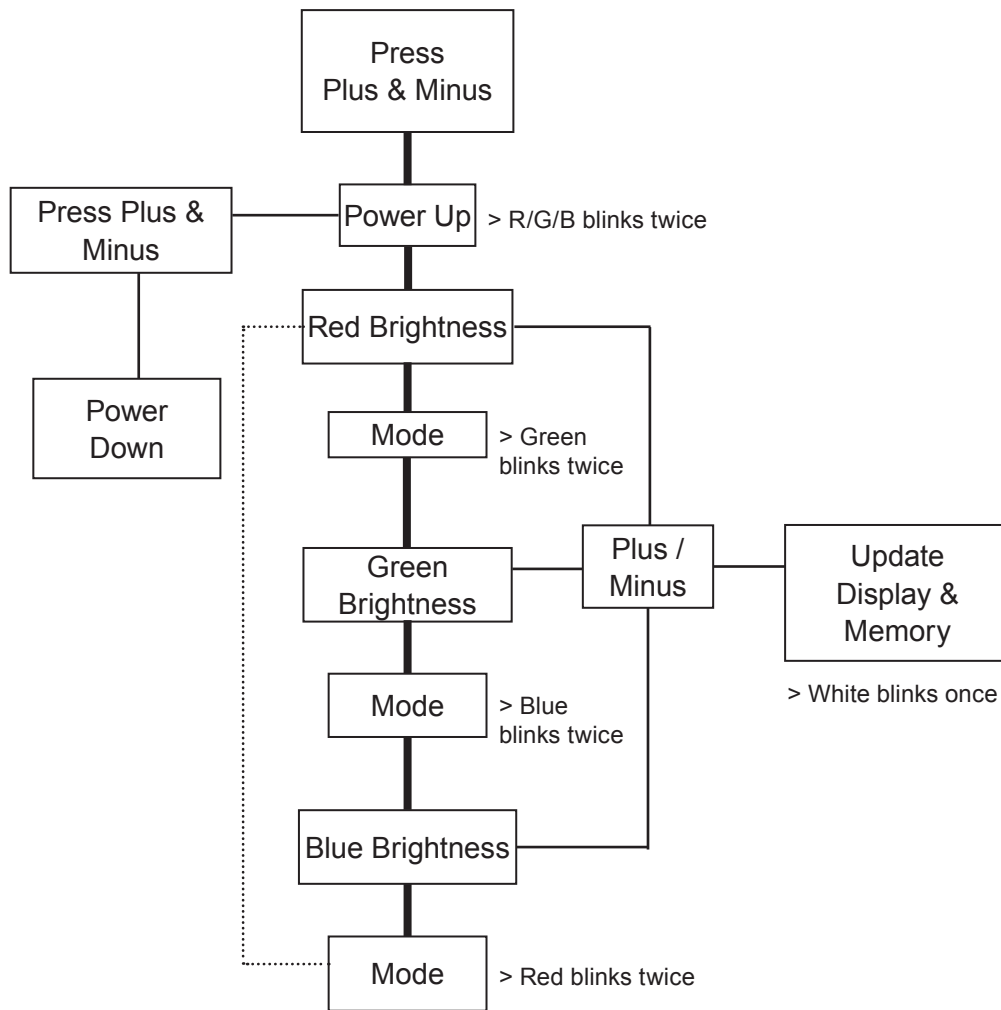

5. Press once or press and hold the Plus button to increase red brightness. Press once or press and hold the Minus button to decrease green brightness. While either button is pressed, the green light will be lit. If the display is increased or decreased to maximum or minimum luminance, respectively, the green light will blink quickly.
6. Press the Mode button for one second to change from green brightness mode to blue brightness mode. The blue light will blink twice indicating the mode change.
7. Press once or press and hold the Plus button to increase blue brightness. Press once or press and hold the Minus button to decrease blue brightness. While either button is pressed, the blue light will be lit. If the display is increased or decreased to maximum or minimum luminance, respectively, the blue light will blink quickly.
8. Press the Mode button for one second to change from blue brightness mode back to red brightness mode. The red light will blink twice indicating the mode change. Go back to the beginning of Calibration Operation or continue to (9).
9. After two seconds, the white light will blink once to indicate the memory being set with the current red, green, blue brightness.
10. To re-enter Normal Operation, disconnect power and reapply.

## Reset Operation

1. Before power up, Reset Operation can be entered by pressing and holding the Mode and Minus buttons simultaneously and then applying power.
2. Release the Mode and Minus buttons and the display will be reset to factory settings, which are:
  - a. SVGA input
  - b. Right-eye orientation
  - c. Median color brightness, contrast, and luminance
3. After two seconds, the white light will blink once to indicate the memory being set with the current settings:
4. Go to Normal Operation.

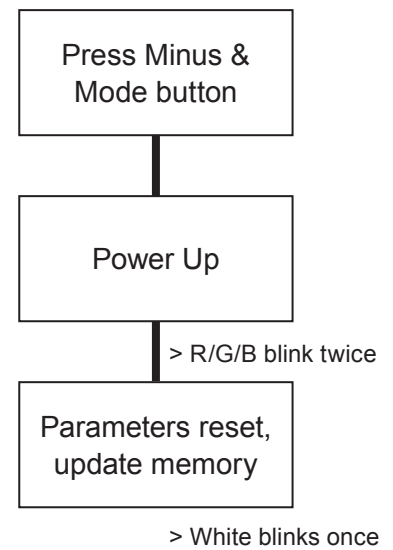

## Normal Operation

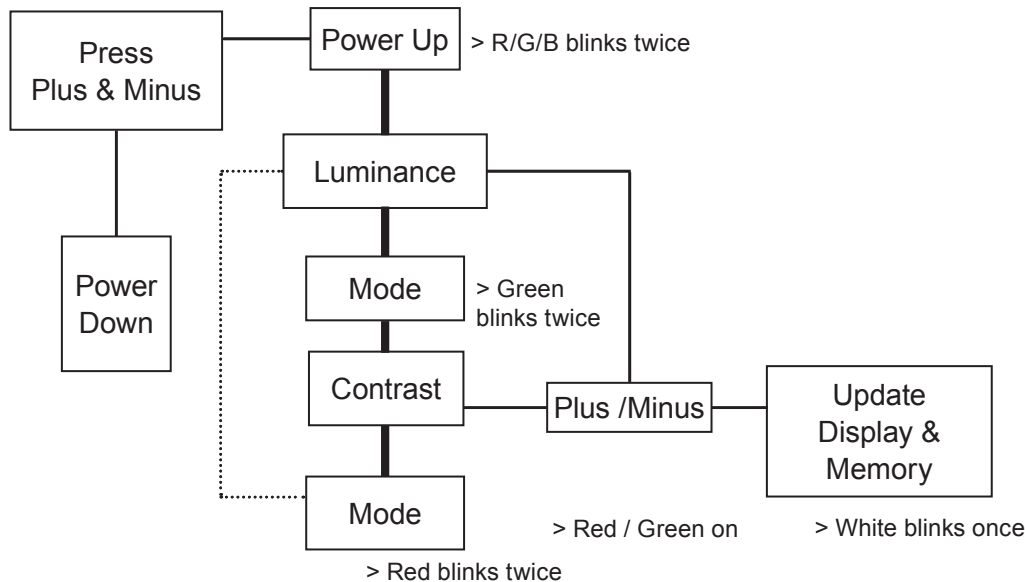

1. Press once or press and hold the Plus button to increase luminance. Press once or press and hold the Minus button to decrease luminance. While either button is pressed, the red light will be lit. If the display is increased or decreased to maximum or minimum luminance, respectively, the red light will blink quickly.
2. Press the Mode button for one second to change from luminance mode to contrast mode. The green light will blink twice indicating the mode change.
3. Press once or press and hold the Plus button to increase contrast. Press once or press and hold the Minus button to decrease contrast. While either button is pressed, the green light will be lit. If the display is increased or decreased to maximum or minimum contrast, respectively, the green light will blink quickly

4. Press the Mode button for one second to change from contrast mode back to luminance mode. The red light will blink twice indicating the mode change.
5. After two seconds, the white light will blink once to indicate the memory being set with the current settings.

### **Power Down**

1. Press and hold the Plus & Minus buttons simultaneously for two seconds and the display will turn off.
2. The red/green/blue lights blink twice.
3. The Plus, Minus, and Mode buttons will be inactive while the display is off.
4. Go to Power Up sequence.

### **Power up & Operation**

1. Press and hold the Plus & Minus buttons simultaneously (or the Power button if using a UI Box) for two seconds and the display will turn on. The buttons do not have to be released during this time to turn the display on.
2. All buttons will now be functional.
3. Go to Operation sequence.

# WEISSCAM HS-2

## 3. Troubleshooting



Problem	<ul style="list-style-type: none"> <li>● <b>Cause</b></li> <li>&gt;&gt; <b>possible solution</b></li> </ul>
WEISSCAM HS-2 does not start	<ul style="list-style-type: none"> <li>● No power source connected</li> <li>&gt;&gt; Connect power source Power source must supply the correct voltage (12 - 24V DC), above all for battery operation</li> <li>&gt;&gt; Replace battery</li> <li>● Cable defective or incorrect pin assignment</li> <li>&gt;&gt; Check / replace cable</li> <li>● Turn-on pulse not received correctly</li> <li>&gt;&gt; Turn the WEISSCAM HS-2 off and back on again</li> </ul>
No image or faulty image at the HD-SDI LINK A / LINK B	<ul style="list-style-type: none"> <li>● Debayerboard started incorrectly</li> <li>&gt;&gt; Turn the WEISSCAM HS-2 off and back on again</li> <li>● Respective port defective</li> <li>&gt;&gt; Plug the BNC cable into the second HD-SDI port (single link)</li> <li>● BNC cable defective</li> <li>&gt;&gt; Replace BNC cable</li> <li>● Target device defective or incompatible</li> <li>&gt;&gt; Connect to another target device (e.g. monitor)</li> <li>● Signal transmission on the BNC cable disrupted by another cable</li> <li>&gt;&gt; Check the cable routing and bypass possible sources of interference</li> </ul>

# WEISSCAM HS-2

Problem	<ul style="list-style-type: none"> <li>● <b>Cause</b></li> <li>&gt;&gt; <b>possible solution</b></li> </ul>
<p>No image or faulty image at RAW LINK A / LINK B</p>	<ul style="list-style-type: none"> <li>● Camera started incorrectly</li> <li>&gt;&gt; Turn the WEISSCAM HS-2 off and back on again</li> <li>● Respective port defective</li> <li>&gt;&gt; Plug the BNC cable into the second RAW port (single link)</li> <li>● BNC cable defective</li> <li>&gt;&gt; Replace BNC cable</li> <li>● Target device defective or incompatible</li> <li>&gt;&gt; Connect to another target device (e.g. monitor)</li> <li>&gt;&gt; The RAW signal cannot be processed by tape recorders (e.g. SRW-1)</li> <li>● Signal transmission on the BNC cable disrupted by another cable</li> <li>&gt;&gt; Check the cable routing and bypass possible sources of interference</li> </ul>
<p>Green image that appears in four quadrants on the monitor</p>	<ul style="list-style-type: none"> <li>● Monitor connected to the RAW LINK A / LINK B, therefore RAW signal displayed</li> <li>&gt;&gt; Connect monitor to the HD-SDI LINK A / LINK B</li> </ul>
<p>WEISSCAM HS-2 is not detected by the Hand Unit HU-2 (Stand alone version)</p>	<ul style="list-style-type: none"> <li>● Hand Unit HU-2 initialised incorrectly</li> <li>&gt;&gt; Turn the Hand Unit HU-2 and/or WEISSCAM HS-2 off and back on again</li> <li>● Connecting cable defective</li> <li>&gt;&gt; Replace connecting cable</li> <li>● Radio channels do not match (wireless mode)</li> <li>&gt;&gt; Set the same radio channel on the Hand Unit HU-2 and camin</li> <li>&gt;&gt; If the camera still is not detected, the camin may need to be updated</li> <li>● The camera output or Hand Unit HU-2 input is defective</li> <li>&gt;&gt; Requires repair by a service partner</li> </ul>
<p>Multiple WEISSCAM HS-2 cameras cannot be synchronised</p>	<ul style="list-style-type: none"> <li>● Connecting cable (BNC) defective or disrupted</li> <li>&gt;&gt; Check and replace cable</li> <li>● No master camera specified</li> <li>&gt;&gt; Master camera is specified via adapter (short-circuit)</li> </ul>



Problem	<ul style="list-style-type: none"> <li>● <b>Cause</b></li> <li>&gt;&gt; <b>possible solution</b></li> </ul>
No image on the viewfinder (electronic)	<ul style="list-style-type: none"> <li>● No power supply</li> <li>&gt;&gt; Connect power supply</li> <li>&gt;&gt; Test both current outputs (12V DC) of the camera</li> <li>&gt;&gt; Check cable</li> <li>● Video adapter (DVI-VGA) defective</li> <li>&gt;&gt; Replace video adapter</li> <li>● Debayerboard started incorrectly</li> <li>&gt;&gt; Turn the WEISSCAM HS-2 off and back on again</li> <li>● Viewfinder receives false signal</li> <li>&gt;&gt; Output must supply SVGA 800x600 (standard with WEISSCAM HS-2)</li> <li>● Viewfinder defective</li> <li>&gt;&gt; Requires replacement or repair by a service partner</li> </ul>
The lens cannot be fastened to the mount	<ul style="list-style-type: none"> <li>● Incorrect IMS mount attached</li> <li>&gt;&gt; Use the correct IMS mount for the respective lens</li> <li>● No IMS mount attached</li> <li>&gt;&gt; The IMS mount must always be used (even with PL mount lenses), since otherwise the sensor could be damaged</li> </ul>
WEISSCAM HS-2 is not detected by the software (basic version)	<ul style="list-style-type: none"> <li>● WEISSCAM HS-2 connected to the PC system incorrectly</li> <li>&gt;&gt; Check or replace connecting cable</li> <li>● WEISSCAM HS-2 initialised incorrectly</li> <li>&gt;&gt; Turn the camera off and back on, then restart the software as well</li> <li>&gt;&gt; If necessary, restart the PC system or test another PC system</li> <li>● Software started before camera</li> <li>&gt;&gt; First start the WEISSCAM HS-2 and wait until it has booted completely. Only then start the software.</li> </ul>

# WEISSCAM

## HS-2

## 4. Technical Specifications

Power Voltage:	24V DC, Fischer 2-pin
Slave:	24V DC, Fischer 2-pin
Power Consumption:	80W
Operating Temperature:	5° C - 40° C
Storage Temperature:	0° C - 50° C
Mass:	ca. 6,8 kg
Dimensions:	H: 210,4mm L: 315,9mm B: 200,7mm
Imager Configuration:	Single CMOS Sensor
Dimensions Sensor:	22,176mm x 22,176mm
Effective picture Elements:	2016 x 2016 pixels
Pixel size:	0,011 mm
Sensitivity:	600 ASA
Dynamic Range:	8 - 10 T-Stops, up to the selected curve
Shutter:	Global Shutter
Lens Mount:	Interchangeble Mount System (different Mounts possible)
Output (Image):	2x HD over HD-SDI, 2x RAW over HD-SDI, 1x Monitor Single Link (SMPTE 292M)/Dual Link (SMPTE 372M)
RAW Signal:	12Bit uncompressed WEISSCAM RAW
HD Signal:	10 Bit YCbCr 4:2:2
RAM:	16GB or 32GB
Output (Power):	1x 12Vdc / 0,5A (Lemo 4Pin), 1x 12Vdc / 3A (Lemo 4Pin), 1x 24Vdc / 3A (Fischer 3-pin)

### WEISSCAM power supply:

Possible input:	100 – 240VAC / 4A max, 45 – 65 Hz
Possible output:	2x 24VDC / 10A max, 240W max
Mass:	3 kg
Dimensions	156mm x 81mm x 290mm

# WEISSCAM HS-2

## Pin assignment of connectors

<b>Hand Unit HU-2:</b>	Connector type	7-pin Fischer
	1:	GND
	2:	RS232 TXD
	3:	RS232 RXD
	4:	CBUS-H (intra-system BUS)
	5:	CBUS-L (intra-system BUS)
	6:	GPIO (general purpose input & output)
7:	+24VDC / 0.5A (out)	
<b>MASTER/SLAVE 24V DC IN:</b>	Connector type	2-pin Fischer
	1:	GND
2:	+24V	
<b>12V/0.5A DC OUT:</b>	Connector type	4-pin Lemo
	1:	GND
	2:	N/D
	3:	N/D
4:	+12VDC / 0.5A	
<b>24V/3A DC OUT:</b>	Connector type	3-pin Fischer
	1:	GND
	2:	+24VDC / 3A
3:	N/D	
<b>WEISSCAM power supply:</b>	Socket type	4-pin XLR
	1:	GND
	2:	N/D
	3:	+24V
4:	N/D	

## VIEWFINDER

Weight (with holder):	770 grams
Dimensions (with holder):	L = 125 mm W = 175 mm
Diameter of Eyepiece:	65 mm
Resolution:	800 x 600 pixel
Light source:	OLED Technology
Connectors:	Power connector: 4-pin Lemo  Video connector: VGA (use with DVI to VGA Adapter)
Accessories:	Standard eyepiece cup, Accessories can be use and can easily be exchanged  3 axis adjustable viewfinder holder, can be attached to the WEISSCAM HS-2

# WEISSCAM

## HS-2

## 5. Addresses and Contacts

### Manufacturer Information

The manufacturer of this product is

#### **P+S Technik GmbH**

Siemensstraße 12  
85521 Ottobrunn/Munich  
Germany

Phone +49-(0)89-45 09 82-30  
Fax +49-(0)89-45 09 82-40  
Email [weisscam@pstechnik.de](mailto:weisscam@pstechnik.de)  
Web [www.pstechnik.de](http://www.pstechnik.de)

Please find worldwide authorised representation and dealer on our website [www.pstechnik.de](http://www.pstechnik.de) in the rental section or send an e-mail to [weisscam@pstechnik.de](mailto:weisscam@pstechnik.de) requesting the contact details.

Concerning any service and warranty requests, please contact your local distributor or P+S Technik directly by email at [helpdesk@pstechnik.de](mailto:helpdesk@pstechnik.de)

