

Javelin[®]

User's manual J330i



JAVELIN

© NBS Technologies - April 2006
Rev. A

Quick Start

1. Unpack your Javelin card printer

Make sure the following items are included:

- Power & USB cable
- Colour ribbon
- Cleaning cartridge
- Driver and documentation CD
- Cleaning kit
- Quick Start guide

If any items are missing, please contact your dealer.

2. Install card cleaning cartridge

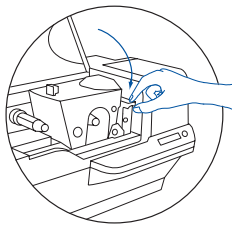

The card cleaning cartridge is packed separately from the printer in a protective plastic bag. Remove carefully and peel off tape before installation.

A loud 'CLICK' will indicate the cartridge is correctly installed.

3. Prepare card output hopper

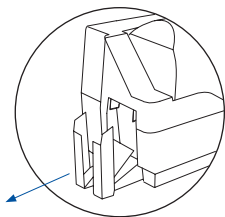

Grab the sides of the hopper and slide out.

4. Loading ribbon

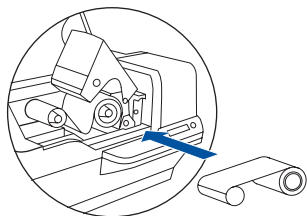

Turn on the power to the printer and raise the printhead.

Ribbon loading involves the placement of the ribbon onto the supply and take-up spindles.

As soon as the ribbon is installed and the printhead is locked down, the spindles will automatically rotate to take up any slack and to synchronise the ribbon to the correct panel.

5. Loading cards

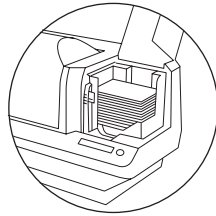

First shuffle a stack of new cards to reduce any electrostatic charge. Always handle cards by their edges.

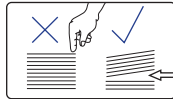

Do not try to eliminate the gap by pressing down on the card stack as this can cause a misfeed.

6. Set card thickness control lever

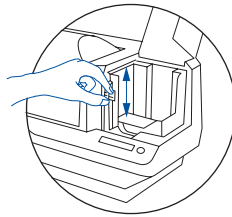

This item can be operated by the user to set the card thickness and to prevent more than one card feeding into the printer at the same time and causing a jam.

There are 4 positions to set the card thickness control.

Slide the lever to set the gauge.



The second position down is the normal position (30mil/0.76mm)

7. Starting to print cards

Connect the interface cable, install the Windows driver on your PC and connect your printer when prompted.

Table of Contents

1	Introduction	7
	Printer features	
	Controls, connectors, and indicators	
	LCD panel	
2	Installation and Setup	10
	General information	
	Unpacking the printer	
	Installing the print driver software and setting driver options	
	Installing the J330i print driver	
	Loading a ribbon	
	Installing the card cleaning cartridge	
	Setting the card thickness control	
	Loading cards	
	Card output hopper	
	Large feeder extension kit	
	Connecting the printer to your computer	
	Connecting power	
	Printing a test card	
3	Printing a Card	23
	Setting printer properties	
	Printing a sample card	
	Feeding one card at a time	
4	Cleaning	28
	Cleaning the printer	
	When to clean	
	How to clean	
	Cleaning the printhead	
	Card cleaning cartridge	
	When to replace the cleaning roller	
	How to replace the cleaning roller	

5	Troubleshooting	34
	Print quality issues	
	Troubleshooting the ethernet connection and adapter	
	Resetting to factory defaults	
	Ethernet adapter status indicator	
	Network status/activity indicator	
6	Technical Specifications	41
	General specifications	
	Ribbon specifications	
	Card specifications	
	Bar codes	
	Fonts	
	Card dimensions	
	Bi-directional communications interfaces	
	Mechanical specifications	
	Electrical	
	Environmental	
	Options	
	Appendix A Magnetic Card Stripe Encoder	44
	Introduction	
	Media loading orientation	
	Sample encoding program	
	Magnetic encoder cleaning	
	When to clean	
	How to clean	
	ISO standard encoding	
	Appendix B Smart Card Contact Station	47
	Introduction	
	Media loading orientation	
	Smart card contact station interface	

Appendix C Connecting to a Network	49
Printer sharing	
External print server	
Internal print server	
Appendix D Accessories & Supplies	51
Ribbons	
Cards	
Accessories	
Appendix E Warranty Information	55
Printers	
Printheads	
Supplies	
Spare parts	
Appendix F Technical Support	56
How to return your printer	
Appendix G Declarations of Conformity	57

1 Introduction

Thank you for choosing the Javelin J330i card printer.
This manual guides you to efficient start up and operation of your new card printer.

Printer Features

The following shows the main functional features found on your J330i printer.

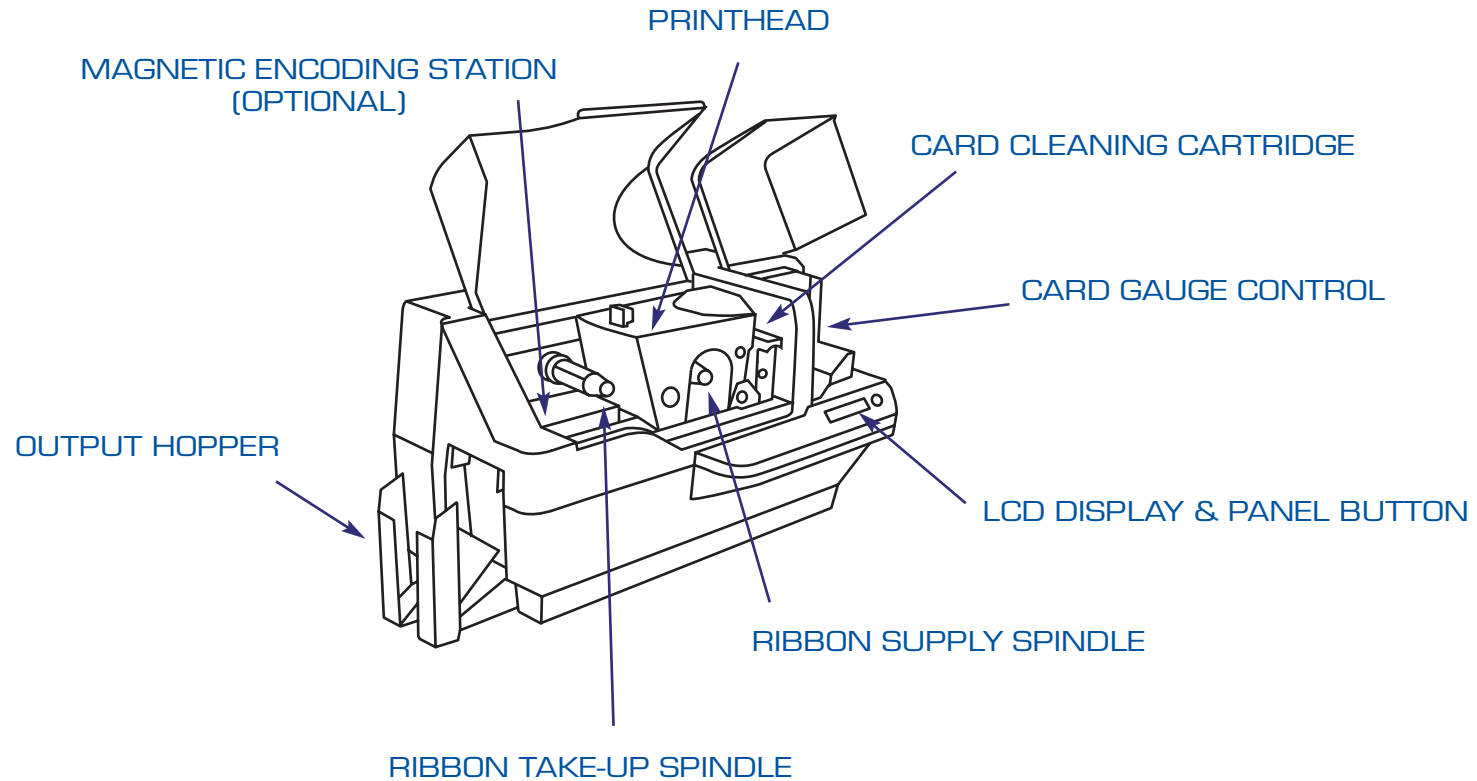

Controls, Connectors, and Indicators

Your J330i printer has an LCD display panel and a panel button on the front and a power connector, power switch, and interface connectors on the rear panel.

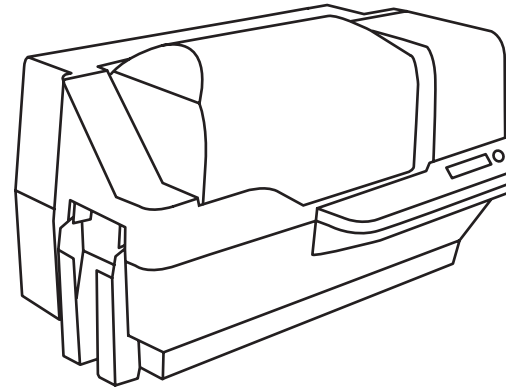

LCD DISPLAY & PANEL BUTTON

10/100 BASE-T CONNECTOR,
ETHERNET SWITCH,
NETWORK STATUS/ACTIVITY LED,
ETHERNET ADAPTOR STATUS LED
(THESE ARE ON THE OPTIONAL ETHERNET ADAPTOR)

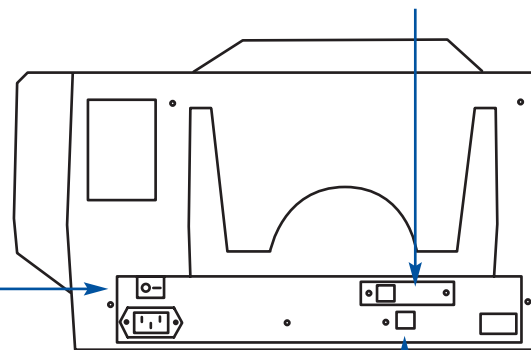

POWER SWITCH

POWER CONNECTOR

USB CONNECTOR

DB-9 CONNECTOR
LOCATION FOR SMART
CARD STATION (OPTIONAL)

LCD Panel

The LCD panel can display the following messages:

Message	Mode
Operational:	
INITIALISING	Scrolling
READY	Fixed
DOWNLOADING DATA	Fixed
PRINTING MONO	Fixed
MAG ENCODING	Fixed
CONTACT ENCODING	Fixed
PRINTING CYAN	Fixed
PRINTING YELLOW	Fixed
PRINTING MAGENTA	Fixed
PRINTING BLACK	Fixed
PRINTING OVERLAY	Fixed
DOWNLOADING FW	Fixed
CLEANING PRINTER	Fixed
Warnings:	
CLEAN PRINTER	Scrolling
REMOVE RIBBON THEN CLOSE HEAD	Scrolling
EMPTY FEEDER & PRESS BUTTON	Scrolling
LOAD CLEANING CARD IN FEEDER	Scrolling
PRESS BUTTON TO CONTINUE	Scrolling
FEED LONG CLEANING CARD IN EXIT	Scrolling
CLEANING PRINTER	Scrolling
ENCODING ERROR (printing stops)	Blinking
INVALID MAGNETIC DATA (encoding stops)	Scrolling
REMOVE RIBBON	Fixed
Errors (Printer will not operate):	
OUT OF RIBBON	Blinking
MECHANICAL ERROR	Blinking
OUT OF CARDS	Blinking
PRINT HEAD OPEN	Blinking

2 Installation and Setup

General Information

This section will guide you through the installation and setup of your J330i printer. This consists of the following procedures, which should be performed in the order presented.

- Unpacking the printer
- Installing the print driver software and setting driver options
- Loading a ribbon
- Installing the card cleaning cartridge
- Setting the card thickness control
- Loading cards
- Connecting the printer to your computer
- Connecting power
- Printing a test card to verify printer operation

The printer should be placed in a location that allows easy access to all sides.

The printer should never be operated while resting on its side or upside down.

Electric Shock Caution: Limit AC power supplied to the J330i printer to 110 ~ 230 volts, 60 ~ 50 Hertz. Limit excess current draw to 16 amps or less, using an associated circuit breaker or other such device.



Never operate the printer in a location where operator, computer, or printer can get wet. Personal injury could result.

The printer must be connected to an earthed electrical power source and properly protected against electrical surges and grounding faults; the electrical reliability of the printer is based on the reliability of the mains power source and with the earth connection. The printer's power supply is an internal unit that can only be serviced or replaced by trained and authorised personnel.

Unpacking the Printer

Your J330i printer ships in a carton and protective anti-static bag. Keep all packaging material in case you need to move or reship the printer.

Inspect the shipping container to ensure that no damage has occurred during shipment. If any damage is apparent, file a claim with the shipper.

Please ensure that you have a clean and nearly dust free environment for proper operation and storage of the printer.

Make sure the following items are included with your J330i printer:

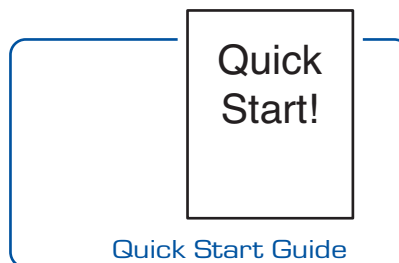
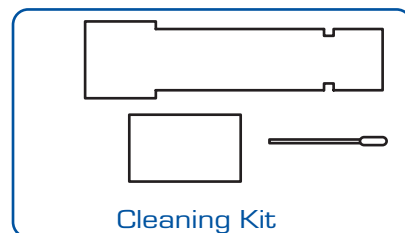
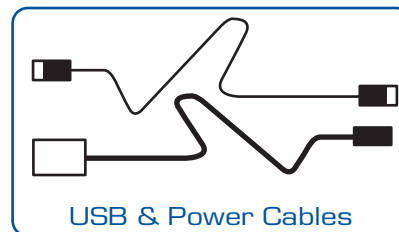
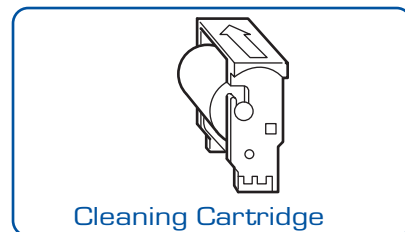
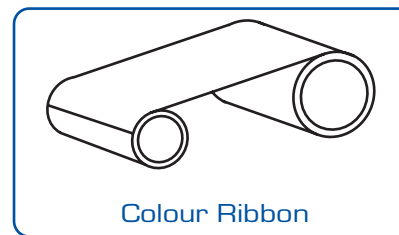
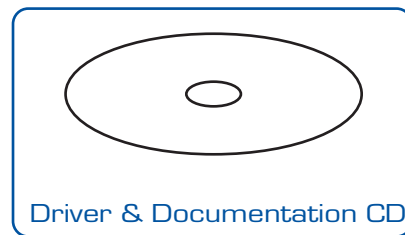

If any items are missing, please contact your dealer.

Your J330i printer ships with warning tape where the card cleaning cartridge will be installed, and a pad that protects the printhead from possible damage in shipment.

- 1 Open the printer's main cover.
- 2 Remove the cleaning cartridge warning tape.
- 3 Release the printhead carriage by pushing the printhead carriage latch to the left, and raise the printhead carriage. It will remain open at about a 45° angle.
- 4 Remove the printhead protection pad.

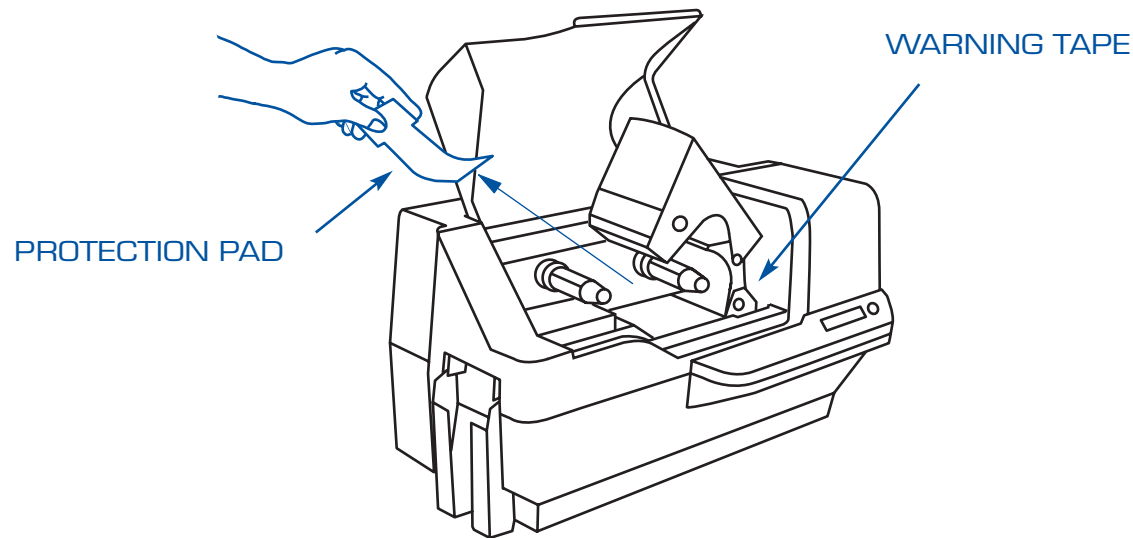

Keep the pad, as well as the other packing material and the shipping carton, in case the printer is shipped or moved.

Installing the print driver software and setting driver options

Printing with the J330i printer requires the Windows printer driver and your card design/issuing software or printer command level programming through the printer interface.

The J330i card printer can be used with any Windows 2000 or Windows XP computer, using the drivers provided on CD with the printer.

This section contains information on the printing of a sample card in colour (using the 5-panel colour ribbon YMCKO and the Windows printer driver).

Note: If updating the printer driver from a previous version, before installing the updated printer driver version, always delete the existing version from your computer.

Installing the J330i print driver

To install the J330i printer driver automatically on all operating systems, use the Javelin Install Wizard.

Note: Ensure that you have administrative privileges to perform this installation, or contact your IT department.

The Install Wizard will walk you through the appropriate installation steps. The Wizard will:

- Automatically launch when the driver CD is inserted.

- From the main menu of your documentation CD, select your desired language and then select 'DRIVERS' from the subsequent menu. The Install Wizard will walk you through the appropriate steps.

- Delete previous versions of the driver and clean up any necessary registry entries. You must select 'Remove' from the install options to remove any previous driver versions.

Loading a Ribbon

Javelin i-series printers require the use of Javelin encoded i-series ribbons for full colour printing. The resin thermal transfer and dye sublimation ribbons for J330i are specifically designed for your J330i printer.

- 1 Place the printer power switch in the OFF (O) position.
- 2 Raise the printhead carriage by pressing the release latch to the left (toward the output hopper) and lifting as shown below to about a 45° angle. The printhead carriage will stay in that position.



Electrostatic discharge caution: DO NOT TOUCH the printhead or the electronic components on the printhead carriage. Discharges of electrostatic energy that accumulate on the human body or other surfaces can damage the printhead or other electronic components used in the printer.

Note: Avoid any direct contact with the printhead to prevent transfer of oils or contamination. Outside of normal operation, only the NBS - approved cleaning materials should come in contact with the print head.

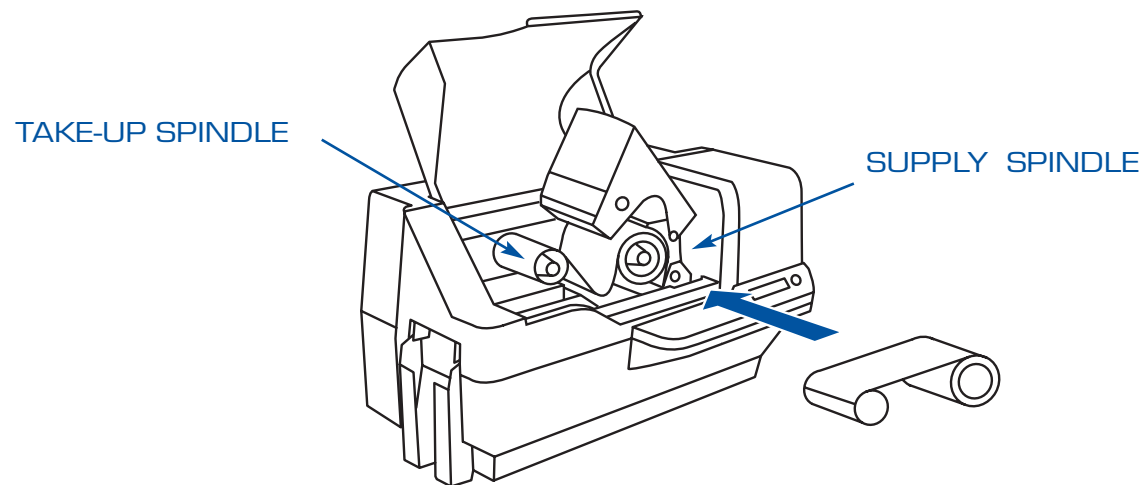

- 3 Locate the ribbon supply spindle and the ribbon take-up spindle (see above). Load ribbon onto the supply spindle (under the printhead carriage) flange side in, and load the empty core (with tape attached) onto the take-up spindle. Make sure the ribbon comes off the top of the supply spindle and feeds to the top of the take-up spindle.

- 5 Gently press the printhead carriage down until it is fully lowered, as shown below. Very little force is necessary to perform this step.



Caution: Do not touch the printhead if the printer has been in service within the last 10 minutes. It could be very hot and cause a burn.

Electrostatic discharge caution: A static discharge is possible if you touch any exposed metal parts. Use of an anti-static wrist strap or comparable anti-static protection is required.

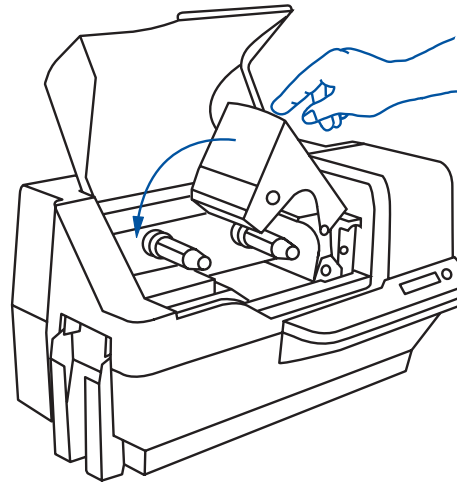

Note: During normal operation (with power connected and turned on), the ribbon would automatically synchronise when the printhead is restored to its fully-down position. The ribbon would be identified and the corresponding parameters sent to the driver.

Since power is not connected at this point in the installation and setup procedure, nothing will happen when the printhead carriage is closed. The ribbon will synchronise when power is turned on.

Installing the Card Cleaning Cartridge

The card cleaning cartridge cleans the cards entering the printer and consists of a cartridge frame and an adhesive roller, which are packed together.

- 1 Remove the cartridge frame and the adhesive roller from their packaging. Insert the adhesive roller into the cartridge frame. To avoid contamination, always hold the frame and the roller by the ends and peel the protective wrapper from the adhesive roller.

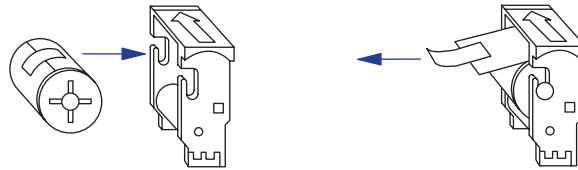

- 2 Open the printer's main cover and locate the area where the card cleaning cartridge will be installed (initially, this area was covered by a warning tape).
- 3 Locate the slot at the rear of the card cleaning cartridge mounting location.

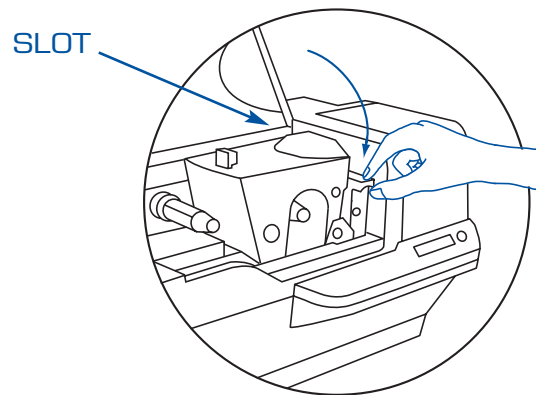

- 4 Hold the card cleaning cartridge by the extended 'handle' (so the large arrow on the top is pointing away from you). With the cartridge at about a 30° angle (pointing downward), insert the lip of the cartridge into the slot, until the cartridge seats against the back wall. Then press the front of the cartridge down until it seats all the way down and latches with an audible 'click'.
- 5 Close the printer's main cover.

Setting the Card Thickness Control

The card thickness control is set by the user to adjust the gap as cards enter the printer, to prevent double-feeds (which could cause a jam) or mis-feeds.

- 1 Open the card feeder cover.

The card thickness control lever is at the front of the left-side opening of the card feeder area

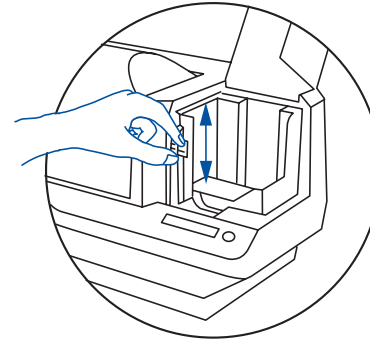





Note: Set the card thickness control before loading cards.

Note: To reduce contamination and ensure better print quality, minimise the time the card feeder cover is open.

There are four positions to set card thickness control.

- 2 Slide the card thickness control to the position corresponding to the following:

	Highest position:	50 mil (1.27 mm) to 60 mil (1.52 mm)
	2nd position:	30 mil (0.76 mm) to 50 mil (1.27 mm) - Normal setting.
	3rd position:	20 mil (0.51 mm) to 40 mil (1.02 mm)
	Lowest position:	10 mil (0.25 mm) to 20 mil (0.51 mm)

Note: The overlap in settings above accommodates variations in environmental conditions (especially humidity) and cards from different manufacturers. In general, start at the lowest position and move the lever up until cards feed reliably.

Note: "60 mil" ("1.524 mm") cards may have a significant variation (over 10%) in the actual thickness of the cards; do not use these cards unless each card has been measured to have a thickness less than 66 mil (1.676 mm).

Loading Cards

This section shows how to load plastic cards into the J330i printer. The J330i can use cards with a range of thickness from 10 mil (0.25 mm) to 60 mil (1.5 mm).

The J330i printer can also load and print cards fed individually. Information on this is given in the next chapter.

The plastic cards generally come in decks of 100 cards; the card feeder can hold a full deck of 100 30-mil cards. Cards sometimes will stick together; this can cause mis-feeding or double feeding. To avoid this, separate the cards before loading.

Note: Do not mix cards of different thicknesses!

Note: Do not bend cards or touch print surfaces as this can reduce print quality.

The surface of the cards must remain clean and dust free. Always store cards in an enclosed container. Ideally, use cards as soon as possible.

Note: For cards with magnetic stripe, refer to Appendix A for loading instructions.

Note: To reduce contamination and ensure better print quality, minimise the time the card feeder cover is open.

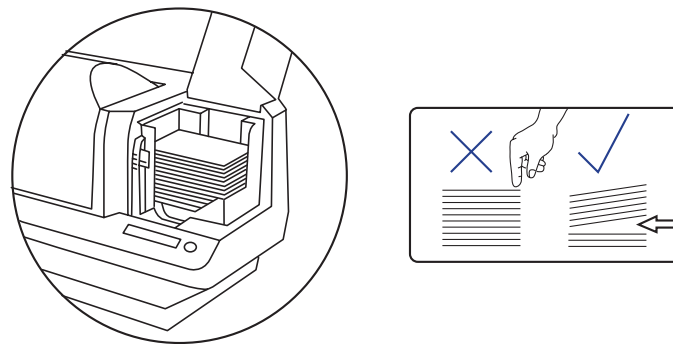

Open card feeder cover and place the cards in the input hopper.

Note: that there will be a 'gap' in the card stack, with several cards lying flat and the cards above angled upward. This is normal and ensures proper feeding.



Caution: Do not touch print surfaces of the cards; this can reduce print quality

Card Output Hopper

This item is used for collecting printed cards.

Grab the sides of the hopper and slide out.

Note: To prevent movement during shipping or operation the hopper is a very snug fit. Firm force is therefore required to change its position.

When the printer is not in use, slide the hopper back into its closed position to protect the printer from dust.

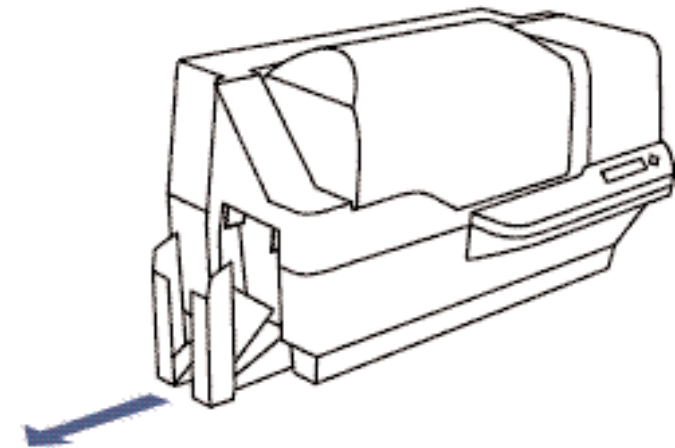

Optional Large Feeder Extension

This item is used for increasing card feeding capacity.

Carefully remove card cover by forcing away from the pivot points.

Slide feeder extension into place and secure by using the 3 screws supplied.

Clip in the door.

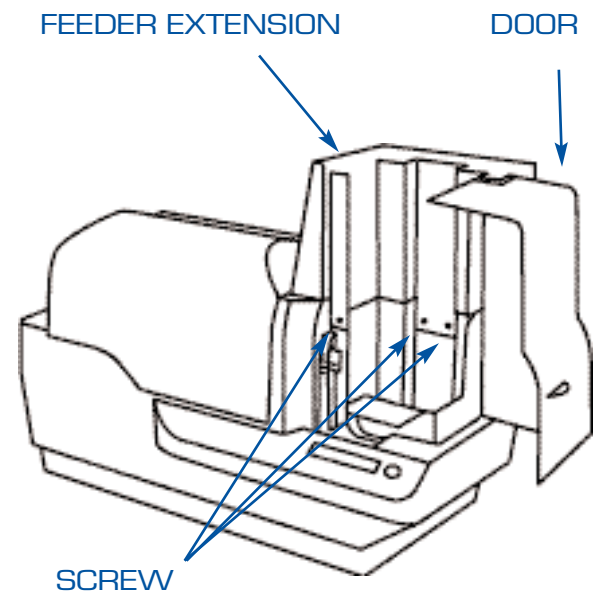

Connecting the Printer to your Computer

The J330i printer includes a standard USB interface.

As an option, the printer can be ordered with a 10/100base-T Ethernet Adapter (in addition to the USB interface).

If using the USB interface, use the supplied USB cable to connect between the USB connector on the printer and a USB port on the computer, as shown below. (Note that the figure below shows the optional Ethernet Adapter directly above the USB Connector; this may not be present on your printer.)

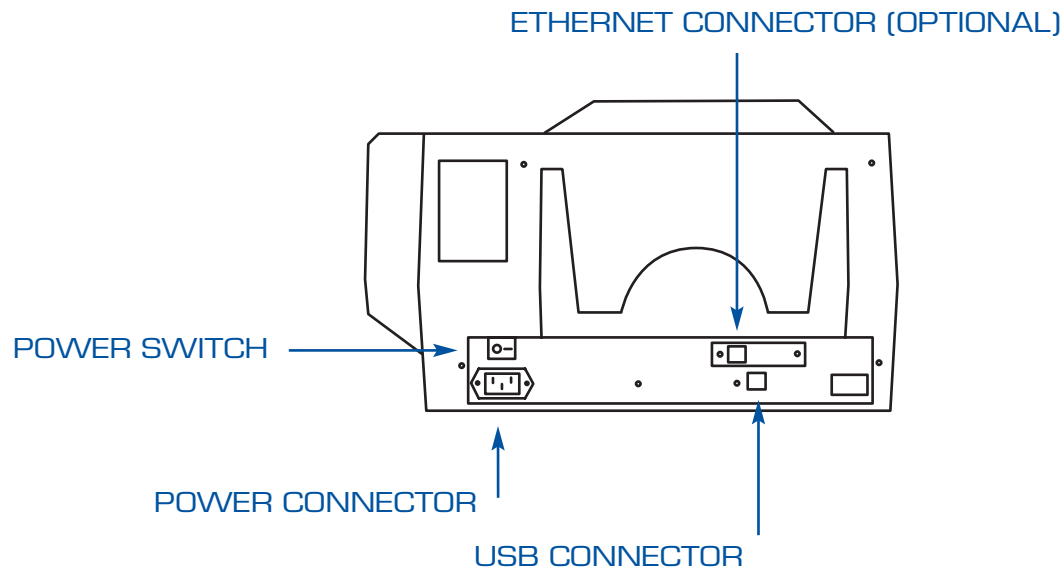

If your printer includes the optional Ethernet Adapter as well as the standard USB connection, use either the supplied USB cable or a standard Ethernet cable to connect the printer to a corresponding port on the computer or network.

Important: Do not use both USB and Ethernet connections at the same time!

Important: Intermittent or unpredictable operation may occur from unsecured connectors. If damaged, the power cable must be replaced by an exact equivalent.

Connecting Power

The J330i printer includes an internal AC power supply that accepts nominal input voltage in the range from 110 to 230 volts at 50 to 60 Hertz. The power source must be grounded.

Depending on specific model number, your J330i printer will include a power cord. If this is not appropriate, AC power cords may be purchased locally; make sure it is a three-wire (grounded) cord.

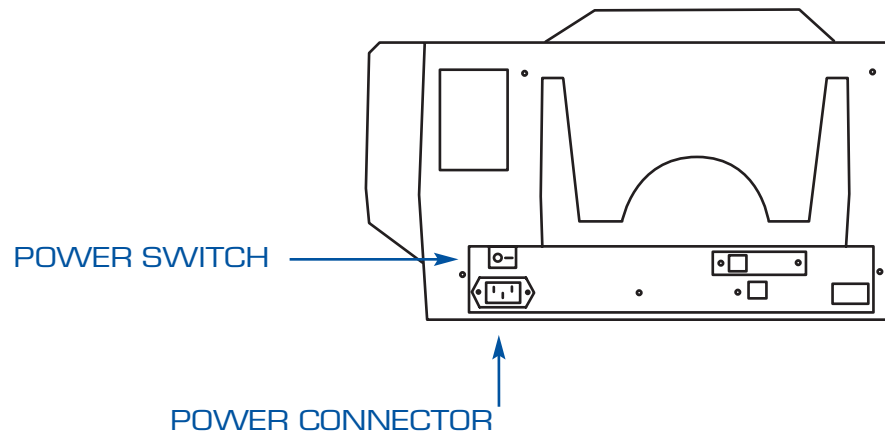

Place the printer's power switch in the OFF (O) position.

Depending on your local AC voltage, plug the appropriate power cord into the printer's power connector and a grounded AC power source connection.

To turn the printer on, set the printer's power switch to the ON (I) position.



Caution: If the power cord appears damaged in any way, or if the power cord will not securely plug into the printer's power connector or the AC power source connection,

STOP! Use of a damaged or incorrect power cord could cause equipment damage, result in an electrical fire, or possibly cause injury.

Printing a Test Card

With ribbon and cards loaded, your J330i printer is ready to print. To check the operation of the printer, you should print a test card. (Printing a test card does not require that the printer be connected to your computer or network, but power must be applied.)

- 1 Set the printer's power switch (on the back of the printer) to the OFF (O) position.
- 2 While pressing the printer's front panel button (next to the LCD display panel), switch the printer ON (I).
- 3 Hold the panel button until the LCD display panel reads "SELF TEST".
- 4 Release the panel button, and the test card will print.

This is an example of the test card:

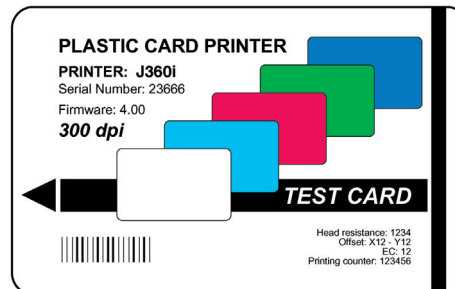

3 Printing a Card

Printing with the J330i card printer is similar to printing with any other printer in a Windows environment.

The printer driver software is installed on your computer (see chapter 2).

The J330i printer is connected to the power source and the computer (see chapter 2).

The J330i printer is selected by either the operating system or the appropriate application software program.

Printer properties are set (the factory default values will be appropriate for many applications).

Card printing is directed by the appropriate application software program.

Setting printer properties

Printer properties can be set either at the operating system level or within the application software program used for printing cards.

Note: In the following description of setting printer properties, only those properties and options that are suitable for being set by the user are described. The user should not make selections or set parameters unless they are specifically described in this section

Preferences settings can configure the J330i card printer for landscape (wide) or portrait (tall) printing orientation, and allow the user to verify that the desired ribbon is installed in the printer. (Monochrome ribbons are selected via the drop-down menu.)

If the J330i printer includes the optional magnetic card stripe encoder, encoding parameters and coercivity can be set.

Printer cleaning can be initiated from the tools window (printer cleaning can also be initiated at the printer; see chapter 4).

Also from the tools window, the test card can be selected from several pre-loaded styles. 'Single feed options' allows disabling or enabling single feed support.

If 'disable single feed support' is selected, when the J330i card printer runs out of cards in the feeder, the LCD display will read OUT OF CARDS. To continue, press the panel button.

If 'enable single feed support' is selected, when the J330i card printer runs out of cards in the feeder it will wait until a card is inserted in the single-card slot or cards are loaded in the feeder, and then will automatically continue.

Printing a Sample Card

Sample card designs are installed with the printer driver. Sample cards require Microsoft Word or Microsoft Paint application software. The cards are accessed via the start menu. Select start, select programs, select Javelin card printers, and select a sample card, or follow the directions below to design a card.

Follow these steps to design and print your first card:

- 1 Launch Microsoft Word software. Depending on your computer configuration this may be done by double-clicking an icon on your desktop, or by clicking the Windows start icon, selecting programs, and navigating to Microsoft Word.
- 2 Go to the **file** menu and choose **page setup**.
- 3 Select the **paper size** tab, choose **card**. Under orientation, select **landscape**.
- 4 Select the **margins** tab, and set the top, bottom, left, and right margins to 0 (zero).
- 5 Click **OK** to close the **page setup** window.
- 6 The card appears on the screen.
- 7 Design a card with both black and coloured text and with coloured pictures (see example below).



Note: For cards thinner than 20 mils (0.51 mm) or thicker than 40 mils (1.02 mm), the card design must be limited to (1) no more than two 30 mm x 30 mm areas of full colour, (2) black information (text and barcode, for example) must cover no more than 50% of the card area, and (3) there must be at least a 5mm unprinted border along all edges. For cards with thickness between 20 mils (0.51 mm) and 40 mils (1.02 mm), these restrictions do not apply; full colour printing is permitted edge to edge in both directions.

- 8 Once you are ready to print, go to the **file** menu and select **print**.
- 9 If the printer was not selected as the default printer, go to the file menu, select **print setup** and choose **Javelin J330i card printer** from the printer names list. Then **close** the **print setup** dialog box.
- 10 The printer will feed in a card and start printing (the data download time will vary depending on the complexity of the card design and the processing speed of your computer).
- 11 Once the printing job is complete, the card is ejected from the printer.

Feeding One Card at a Time

A manual feed slot is available below the card input hopper for feeding single cards.

The card input hopper must be empty for single-card feeding to work properly.

Insert a single card into the slot below the card feeder. Do not feed more than one card at a time.

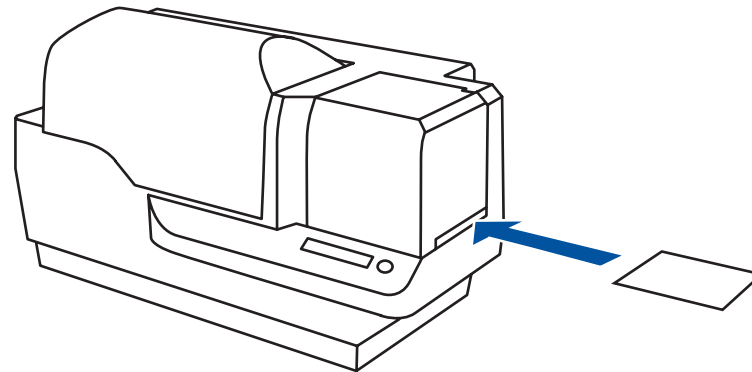

Note: If single-card feeding will be the normal mode of operation, you may select that mode through the driver software. In single-card feed mode, the card will not be printed until the print job has been sent to the printer and the card to be printed has been inserted into the single-card feed slot.

4 Cleaning

Caution: PROTECT YOUR FACTORY WARRANTY!



The recommended cleaning procedures must be performed to maintain your factory warranty. Other than the recommended cleaning procedures described in this manual, allow only Javelin authorised technicians to service the J330i printer.

NEVER loosen, tighten, adjust, bend, etc., any part or cable inside the printer.
NEVER use a high pressure air compressor to remove particles in the printer.

Cleaning the Printer

Clean your J330i printer using pre-saturated cleaning cards provided. The regular use of these cards will clean and maintain important parts of your printer that cannot be reached, including the printhead, transport rollers, and optional magnetic encoder station.

When to Clean

When the LCD Panel displays the message CLEAN PRINTER.

Approximately every 1000 cards when using 5-panel colour ribbon, or every 5000 cards when using a monochrome ribbon.

How to Clean

Note: This cleaning procedure uses two cleaning cards. One cleaning card is the size of a regular plastic card, and is referred to as the 'cleaning card'. The other is elongated, with a wider section at one end; it is referred to as the 'long cleaning card'.

- 1 Turn printer power on.
- 2 Initiate the cleaning process by either of the following methods:

At the printer, press and hold the panel button for several seconds, until the LCD panel displays the message REMOVE RIBBON THEN CLOSE HEAD.
From the computer, enter the J330i printer tools software, and click on the CLEAN button.
The LCD panel will display the message REMOVE RIBBON THEN CLOSE HEAD.
- 3 Open the main cover, release the printhead carriage, and remove the ribbon. Then close the printhead carriage.
(For details, see chapter 2.) The LCD panel will display the message EMPTY FEEDER & PRESS BUTTON.
- 4 Open the card feeder cover and remove cards from the card feeder. The last card is difficult to remove; leave it in place.
Press the panel button on the front of the printer. The card remaining in the feeder will be ejected. The LCD panel will then display the message LOAD CLEANING CARD IN FEEDER.
- 5 Place a pre-saturated cleaning card into the card feeder. The cleaning card will automatically feed into the printer and the cleaning process will start (there is a several second delay after the cleaning card feeds before the cleaning movement starts). While the cleaning process is underway, the LCD panel will display the message CLEANING PRINTER.
- 6 At the conclusion of this part of the cleaning process, the cleaning card will be ejected, and the LCD panel will display the message PRESS BUTTON TO CONTINUE.

- 7 After the user presses the panel button, the LCD panel will display the message FEED LONG CLEANING CARD IN EXIT.
Insert the long end of the long cleaning card into the card exit (directly above the output hopper). If the user inserts a "regular" cleaning card into the card exit, the LCD panel will display the message INVALID CARD, PRESS BUTTON until the user presses the panel button and inserts the long cleaning card into the card exit.

Note: If the user does nothing at this point (ie., does not insert the long cleaning card), after a timeout the LCD panel display will change to CLEAN PRINTER. The printer will be able to print, but the LCD panel will continue to display CLEAN PRINTER.

This limited cleaning does not do a thorough cleaning, but may be performed if no 'long cleaning cards' are available.

To restore the display to READY, you will need to perform a complete cleaning process, using both short and long cleaning cards, from step 2 above through step 9 below.

- 8 The long cleaning card will automatically feed into the printer and the printing process will continue. The LCD panel will again display the message CLEANING PRINTER.
- 9 When the cleaning process is completed, the long cleaning card will be ejected and the LCD panel will display the message READY, indicating that the printer is ready to resume normal printing operations.
- 10 Discard both cleaning cards after a single use.

Note: Do not use previously used cleaning cards.

Cleaning the Printhead

A cleaning using the cleaning cards usually suffices. However, a separate printhead cleaning can remove more stubborn deposits when print anomalies persist. To avoid deposits, only use foam-tipped swabs.

- 1 Place the printer power switch in the OFF (O) position.
- 2 Open the main cover, release the printhead carriage, and remove the ribbon. Leave the printhead carriage in its raised position. (For details, see chapter 2.)
- 3 Clean printhead by moving an alcohol-moistened swab tip side-to-side across the printhead elements. Only use moderate force. To reorder swabs, please refer to the media list on the Windows drivers and user documentation CD supplied with this printer.
- 4 The swabs can also be used in a similar manner to clean the optional magnetic encoding head.



Caution: Never use a sharp object or any abrasive to scrape deposits from the print head. Permanent damage to the printhead will result.

Caution: Do not touch the printhead if the printer has been in service in the last 10 minutes. It could be very hot and cause a burn.

Card Cleaning Cartridge

Your J330i printer includes a card cleaning cartridge. This item cleans the cards entering the printer through the card feeder. To ensure print quality, the cleaning roller requires periodic replacement. New cleaning rollers are included with each ribbon or may be purchased separately.

Installation of the card cleaning cartridge is described in chapter 2 and is not repeated in detail here.

Replace the cleaning roller each time you install a new ribbon.

How To Replace the Cleaning Roller

- 1 Open the main cover and locate the card cleaning cartridge.
- 2 Gently remove the card cleaning cartridge. Lift the 'handle' end, and then pull it away from the printer.

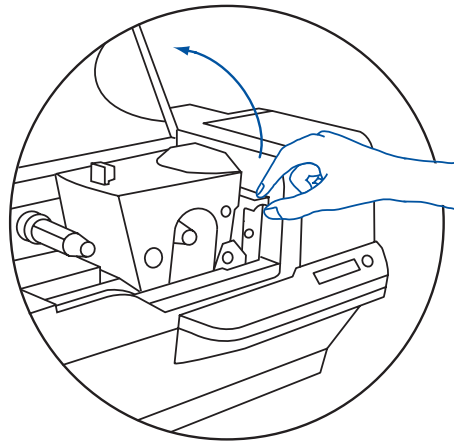

Note: Before replacing the card cleaning cartridge or its cleaning roller, clean the printer using the cleaning cards as described earlier in this chapter.

- 3 Remove the cleaning roller from the card cleaning cartridge and discard.

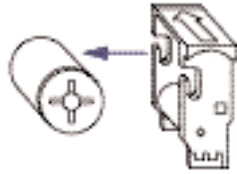

- 4 Install new cleaning roller into the card cleaning cartridge. To avoid contamination, always hold the cleaning roller by the ends.
- 5 Peel protective wrapper from the cleaning roller by gently pulling on the tape.



- 6 Replace the card cleaning cartridge into the printer.
- 7 Close the printer main cover.

Note: Do not touch the adhesive roller surface that contacts the cards.

5 Troubleshooting

The table on the next page offers causes and solutions to symptoms related to improper operation. Check the table when experiencing any loss of operation or print quality.

Problem/Description		Cause/Solution:
OUT OF CARDS	1	Check for cards in the card feeder. If no cards present, load cards.
	2	Check that card thickness control lever is properly adjusted (see loading cards in chapter 2).
	3	Press the panel button for 1 second. The printing job will restart.
OUT OF RIBBON	1	Check ribbon. Replace if defective or entirely used. Ribbon will automatically synchronise and printing will restart with a new card.
PRINT HEAD OPEN	1	Check that printhead carriage is closed and latched.
MECHANICAL ERROR	1	Check that you are using the correct card type (see technical specifications).
	2	Check that card thickness control lever is properly adjusted (see loading cards in chapter 2).
	3	If 2 cards are fed into the printer at the same time: Open cover and remove card cleaning cartridge, empty the card feeder, and pull the jammed cards out. Replace the card cleaning cartridge. Remove cards from card feeder, separate them as shown in Loading cards in chapter 2, and replace.
	4	Check that ribbon is loaded correctly.
ENCODING ERROR	1	Check that you are using the correct magnetic card type (for low or high coercivity encoding).
	2	Verify command syntax.
	3	Contact Javelin technical support.
CLEAN PRINTER	1	Printer cleaning required (see chapter 4).

Print Quality Issues

This section will help you resolve print quality problems. The print quality is dependent on several factors. The two most important factors that will increase your print quality are cleanliness and card stock. To diagnose and fix print quality problems, follow the troubleshooting procedures below:

EXAMPLE 1 Small spots appear on the printed card with a non-printed area or a different colour.

Possible Cause: Contamination on the card surface.

Solutions: Check that cards are stored in a dust free environment.
Use a different supply of cards.

Possible Cause: Dust inside the printer and/or dirty cleaning roller.

Solutions: Perform a cleaning of the printer (see chapter 4).
Replace cleaning roller (see chapter 4).

EXAMPLE 2 There are non-printing horizontal lines (white) on the card surfaces.

Possible Cause: Ribbon cartridge is not correctly positioned.

Solutions: Ensure that the ribbon is properly rolled onto the ribbon cores of the cartridge and that there are no wrinkles in the ribbon.
Replace ribbon cassette, making sure it locks in place.



EXAMPLE 2

Possible Cause: Printhead is dirty.

Solution: Clean the printhead

Possible Cause: Printhead elements are damaged (e.g., scratched or burnt).

Solution: Call NBS customer service for printhead replacement information.

EXAMPLE 3 Printing shows very pale, very dark, or inconsistent results

Possible Cause: Ribbon has been stored improperly or is damaged.

Solution: Change ribbon and print again.

Possible Cause: Cards may not meet specifications.

Solution: Use a different supply of cards.

Possible Cause: Contrast and/or Intensity may be set to incorrect values.

Solution: Adjust contrast and/or Intensity values in software.

Possible Cause: Head Settings are too low / high.

Solution: Adjust head Settings higher / lower.

Possible Cause: Dust or embedded contamination on elements of the printhead.

Solution: Perform a cleaning of the printhead (see chapter 4).



EXAMPLE 3

EXAMPLE 4 Printing shows blurry printed image.

Possible Cause: Ribbon cartridge may not be correctly positioned.

Solution: Check that the ribbon is properly rolled onto the ribbon cores of the cartridge. Replace ribbon cartridge, making sure it locks in place, and print again.

Possible Cause: Ribbon may not be synchronised on the correct colour panel position.

Solution: Open the printhead carriage, then close it. This will cause the ribbon to resynchronise.

Possible Cause: Cards may not meet specifications.

Solution: Use a different supply of cards.

Possible Cause: Dust or embedded contamination inside the printer and/or dirty cleaning roller.

Solution: Clean the printhead. Replace the cleaning roller.

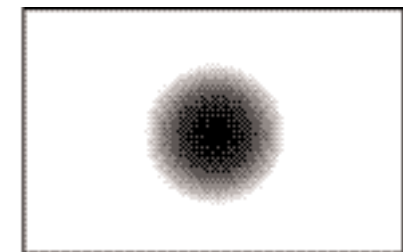

EXAMPLE 4

EXAMPLE 5 No printing on the card.

Possible Cause: Ribbon may not be installed in the printer.

Solution: Check for ribbon in the printer.

Possible Cause: Cards may not meet specifications.

Solution: Use a different supply of cards.

Possible Cause: Printhead elements may be scratched or burnt.

Solution: Call service for printhead replacement information.

EXAMPLE 6 Only one panel of a colour ribbon prints.

Possible Cause: Using the wrong type of ribbon.

Solution: Use only Javelin encoded i-series ribbons for full colour printing.

Note: For optimum print quality, always keep the main cover and the card feeder cover closed.

Troubleshooting the Ethernet Connection and Adapter

Resetting to Factory Defaults

To reset the Ethernet adapter configuration parameters to the factory defaults, press the panel button and hold it in while turning the printer power on. Keep the panel button pressed until the status Indicator light turns green, then release the panel button. To print a configuration card, press and hold the ethernet switch.

Ethernet Adapter Status Indicator

A bi-color status Indicator displays the operational status of the Ethernet adapter. The following conditions might occur:

- 1 During normal operation, the LED is solid green for more than 30 seconds. This indicates all the hardware is functioning properly and the Ethernet adapter has detected the presence of the network. It does not mean the Ethernet adapter has an IP address or is attached to a printer queue.

- 2 If the LED is rapidly flashing green (9 times/sec), the Ethernet adapter has not detected the presence of a network cable. To solve the problem:

Verify that the network cable is appropriate for the network and has an RJ-45 connector.

Turn the printer power off (O). Remove the network cable from the Ethernet adapter. Plug the network cable back in until you hear a positive click. Check the other end of the cable in the same manner. Turn the printer power on; if the Ethernet adapter still does not detect a cable, continue.

Connect the Ethernet adapter to a known good network connection. If the Ethernet adapter is still unable to detect the network cable, contact technical support for assistance.

- 3 If the LED is slowly flashing green (1 time/sec), the Ethernet adapter is trying to print a job. If the job does not print, check the following:

Important: Cables with a rating higher than CAT-6 have not been tested.

Verify that the printer has media and ribbon. If the printer is showing any errors, it is unlikely that the Ethernet adapter can send data to the printer. The LED continues to blink until the printer malfunction is resolved or until the printer is turned off (O).

Flashing red indicates the power on self test (POST) is in progress.

- 4 If the LED is solid red for more than 30 seconds, the Ethernet adapter has failed the POST. A failed POST can be caused by any of the following:

The printer attached to the Ethernet adapter device is malfunctioning. Turn the printer power off, wait 10 seconds, then turn the printer back on (I). If the Ethernet adapter still fails the POST, the Ethernet adapter has a hardware problem that can be fixed only by replacing or returning the unit. Contact technical support for repair or replacement information.

- 5 If the LED is alternately flashing red and green for longer than 2 minutes, the Ethernet adapter is in firmware-download mode. This means it is waiting for new firmware data to be sent before it continues normal functioning. Perform the following:

If the Ethernet adapter was purposely put into firmware-download mode, finish the download with the proper update utility.

Contact the NBS web site at <http://www.nbstech.com> to download this utility. Contact technical support for help recovering this unit.

Network Status/Activity Indicator

A bi-colour status/activity LED indicates network speed, established link, and network activity.

- 1 If the LED is off, no link was established.
- 2 If the LED is solid green, a 100Base link is established.
- 3 If the LED is flashing green, a 100Base link is established and network activity has been detected.
- 4 If the LED is solid orange, a 10Base link is established.
- 5 If the LED is flashing orange, a 10Base link was established and network activity has been detected.

Network activity detected by this LED does not mean the activity is data for the print server. The activity is all activity on the network seen on the Ethernet adapter.

6 Technical Specifications

General Specifications

Full colour dye-sublimation card printing
25 seconds per card single-sided colour printing (YMCKO)
Monochrome thermal transfer printing
4 seconds per card monochrome

Ribbon Specifications

Patented ribbon core and spindle system
i-series technology featuring RFID

Note: 'i series'; printers require the use of Javelin encoded 'i-series' ribbons for full colour printing. For more information about card media and ribbons available from NBS Technologies, please refer to appendix D.

Card Specifications

Types: PVC or composite
Card width/length ISO CR-80 - ISO 7810, 2.125" (54 mm) x 3.375" (86 mm)
Option: magnetic stripe - ISO 7811
Card thickness: 10-60 mil (0.25-1.5 mm) \pm 10%
Card feeder capacity: up to 100 cards (30mil) (optional high-capacity feeder: up to 220 cards)
Card output hopper capacity: 100 cards (30mil)

Bar Codes

Code 39, Code 128 B & C with & without check digit
2 of 5 and 2 of 5 interleaved
UPC-A, EAN8, and EAN13
PDF-417 2D bar code and other symbologies available via Windows printer driver

Fonts

Arial and Arial bold
True type fonts available via Windows driver

Card Dimensions

ISO standard 7810 dimensions
for plain card:

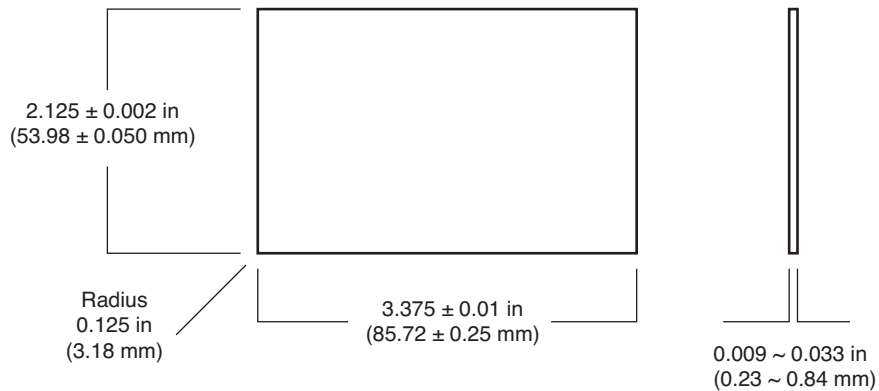

ISO standard 7811 dimensions
for magnetic stripe card:

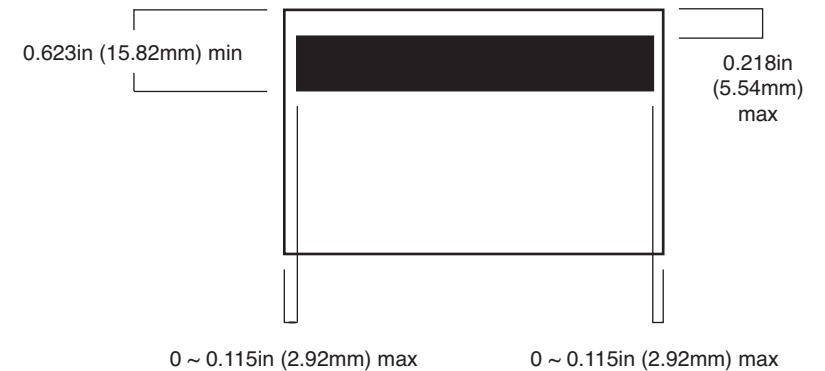

Contact Location for smart card ISO standard 7816:

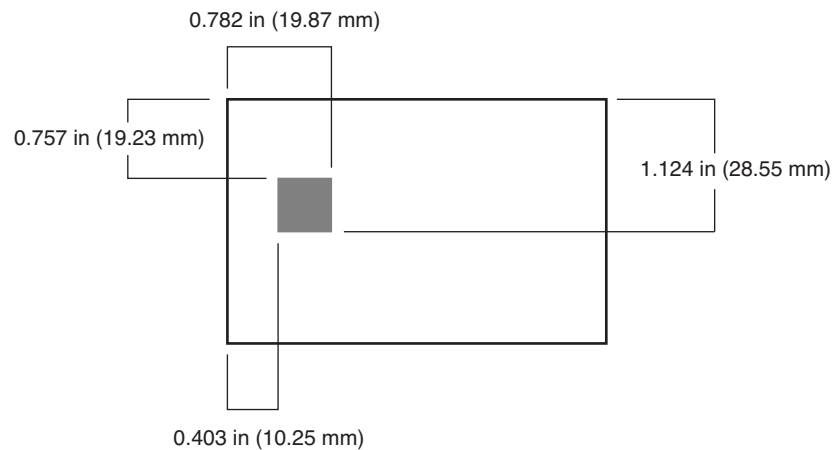

Bi-Directional Communications Interfaces

USB

Built-in Ethernet (optional)

Mechanical Specifications

Width: 462 mm (18.2 in)

Depth: 239 mm (9.4 in)

Height: 256 mm (10.1 in)

Weight: 7.0 kg (15.5 lbs)

Electrical

110 ~ 230 Volts AC \pm 10% (99 - 254 V), 60 ~ 50 Hz \pm 3Hz (47 - 63 Hz)

FCC Class B, CE, UL, and CUL approved

Environmental

Operating temperature: 60°F to 86°F (15°C to 30°C)

Operating humidity: 20% to 65% non condensing

Storage temperature: 23°F to 158°F (-5°C to 70°C)

Storage humidity: 20% to 70% non-condensing

Ventilation: reasonably dust free air environment

Options

Built-in Ethernet network communications

Three track magnetic stripe encoder (standard and reverse)

Smart card contacts station

Contact and contactless smart card encoding kits

Appendix A Magnetic Card Stripe Encoder

Introduction

This appendix includes operation and maintenance requirements for the J330i printer with the optional magnetic card stripe encoder. (See chapter 2 for location of the magnetic card stripe encoder.)

The magnetic encoder can be set for either high or low coercivity. Use the printer driver to change the encoder setting.

Media Loading Orientation

The magnetic encoder may be installed with the read/write head positioned below the card path. Magnetic card stripe encoder upgrade kits are also available.

When loading cards with magnetic stripes into the card feeder, please ensure that the magnetic stripe is down and nearer to the rear of the printer.

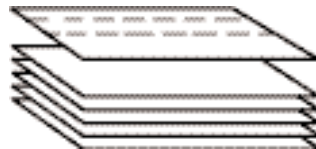

Also available are printer models with the magnetic read/write head positioned above the card path. When loading cards into one of these models, ensure that the magnetic stripe is up and nearer to the rear of the printer.

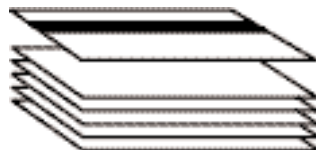

Sample Encoding Program

Refer to the programmer's manual (part number 98001-001).

Note: ONLY USE cards that comply with ISO 7810 and 7811 standards for magnetic stripe cards. The magnetic stripe must be flush to the surface of the card to work properly. Never use cards which have taped-on magnetic stripes.

Magnetic Encoder Cleaning

The magnetic encoder read/write head is cleaned as part of the printer cleaning process. If the frequency of encoding errors increases, the magnetic encoder head may need cleaning.

When to Clean

When the LCD panel displays the message ENCODING ERROR at an increasing frequency.

How to Clean

- 1 Leave power on.
- 2 Press and hold the front panel button for a few seconds.
- 3 Open the main cover and release the printhead carriage latch, raise the printhead carriage, and remove the ribbon. Close the printhead carriage.
- 4 Close the main cover.
- 5 Open the card feeder cover and remove any cards.
- 6 Insert a pre-saturated cleaning card (provided) into the slot below the card feeder. The cleaning card will feed into the printer and carry out the cleaning process. Repeat the process with a new cleaning card if necessary.
- 7 Additional cleaning of the magnetic head can be accomplished using the alcohol-soaked swabs provided with the printer. Follow the directions given in section 4.

ISO Standard Encoding

Track #	Field Separator	Track Density	Valid Characters	# of characters
1	^	210 BPI*	Alphanumeric (ASCII 20~95†)	79‡
2	=	75 BPI*	Numeric (ASCII 48~62)	40‡
3	=	210 BPI*	Numeric (ASCII 48~62)	107‡

*Bits per inch

†Except the "?" character

‡Including Start, Stop, and LRC characters. Also note that these 3 characters are automatically managed by the magnetic encoder according to the ISO standard norms.

Note: Refer to the card printer programmer's manual for complete programming information.

Appendix B Smart Card Contact Station

This section contains information on the additional operations of a J330i printer equipped with the optional smart card contact station. (See chapter 2 for location.)

Introduction

Smart cards can have a built-in microcomputer and/or memory to store fingerprints, voice recognition patterns, medical records, and other such data. The J330i printer may be equipped with an optional contact station for programming smart cards (ISO 7816). This printer model responds to commands that position the card at the contact station, where the printer connects to the contacts on the smart card. All other printer operations remain the same as the standard J330i model.

Media Loading Orientation

Orient the cards with the gold-plated smart card contacts at the top surface of the card and facing to the left.



Smart Card Contact Station Interface

When a command to the printer interface sends a card to the smart card contact station, the printer connects the smart card contact station to the female DB-9 connector on the rear of the printer.

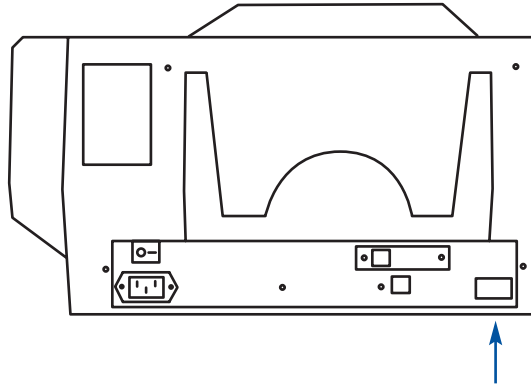

DB-9 CONNECTOR LOCATION FOR SMART CARD STATION (OPTIONAL)

An attached external smart card programmer can be used to program smart card chips. The following table shows the smart card contact points.

DB-9	Pin Smart Card Contact Points	DB-9 Pin	Smart Card Contact Points
1	C1 (VCC)	6	C6 (Vpp)
2	C2 (Reset)	7	C7 (I/O)
3	C3 (Clock)	8	C8 (RFU)
4	C4 (RFU)	9	(GND when chip is at station)
5	C5 (GND)		

APPENDIX C Connecting to a Network

Card printers can be connected to an Ethernet network in three ways:

Printer Sharing

In printer sharing, the printer is connected locally to the host computer and configured to be shared to other client computers. Client computers connect to the printer over the network through the host computer.

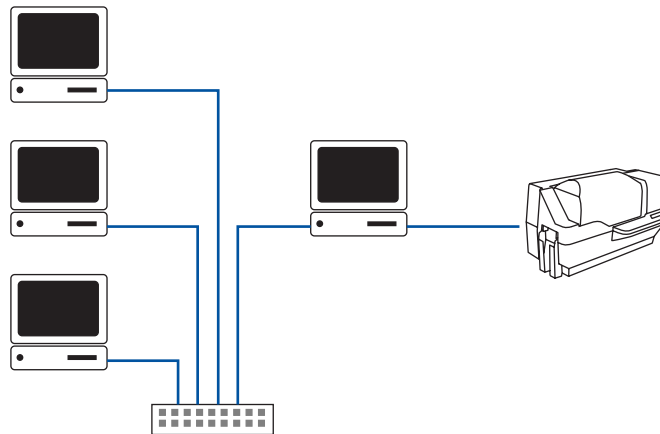

External Print Server

A stand alone device that acts as a server on the network specifically for receiving print jobs and passing them to the printer. Client computers connect to the print server over a network.

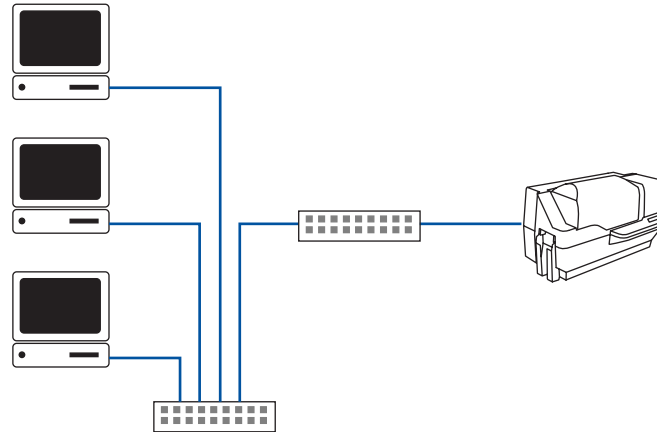

Internal Print Server

Similar to an external print server, except the print server is integrated into the printer. This removes the need for a separate power supply and separate device drivers. This is the simplest way to network a printer.

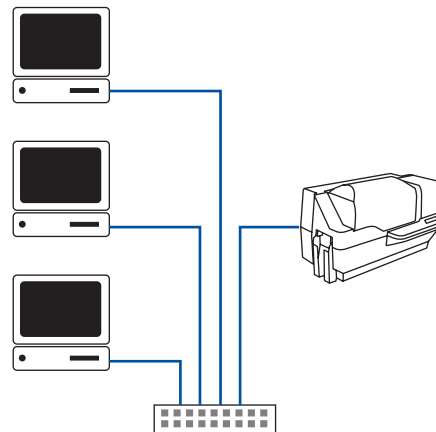

Appendix D Accessories & Supplies

Please contact your Javelin dealer to place an order for accessories and supplies.

IMPORTANT NOTICE:

Only TrueColours™ colour ribbons supplied by Javelin dealers can be used in this printer.

RIBBONS

JAVELIN ENCODED INTELLIGENT RIBBONS.

Each i-series ribbon includes a cleaning roller.

Full colour ribbons

NBS part no.

61134501	Five panel YMCKOi (200 cards)
61134503	Five panel YMCKOi (330 cards)
61134512	Half panel YMC plus full panel KOi (450 cards)

Two panel ribbons

61134509	Black (dye-sub) + overlay KdOi (500 cards) - for monochrome photos
61134510	Black (resin) + overlay KrOi (500 cards) - for text and bar codes

Note : Y = Yellow, M = Magenta, C = Cyan, B = Black , O = Overlay

MONOCHROME RIBBONS

1000 cards unless indicated otherwise.

Original 'blue core' ribbons		NBS Javelin ribbons	
61131100	Black	61131101	Black
61132100	Black (1500 cards)	61131108	Black value pack*
61131107	Black for ABS cards	61131153	White
61131102	Red (PMS 1795C)		
61131103	Green (PMS 348C)		
61131104	Blue (PMS 2935C)		
61131106	White		
61131111	Gold		
61131112	Silver		
61131121	Scratch-off (840 cards)		
			*sold in multiples of 100 rolls
Varnish overlay ribbons (350 cards) applied using printer			
61131701	Clear		
61131702	Genuine secure		
Hand applied peel 'n' stick laminate patches			
61152270	World globe hologram (500 patches)		

PLASTIC CARDS (per 1000 cards)

PVC 30 mil (0.76 mm)

92000009	Plain white cards
92000011	Plain white cards (with low coercivity magnetic stripe)
92000007	Plain white cards (with high coercivity magnetic stripe)
9104523-020	Plain white 30 mil 3-up breakaway key tags
92000700	Plain black cards
92000701	Plain silver cards
92000702	Plain gold cards
9104523-121	Plain white security cards with embedded security star opacity mark
9104523-122	Plain white security cards with lock & key colourshift ink image

PVC 10 mil (0.25 mm)

92000003	Self adhesive cards
9104523-114	Plain white cards
9104523-115	10 mil cards with writeable backs

PVC Composite 60/40 30 mil (0.76 mm)

9104524-101	Plain white cards
9104524-103	Plain white cards (with high coercivity magnetic stripe)
9104524-120	Plain white security cards with embedded world globe hologram design

OTHER CONSUMABLES

61100905	Printhead (J330i)
61100914	Cleaning Kit. Short cards (50) & Swabs (25)
61100915	Short cleaning cards (100)
61100916	Cleaning swap kit (25)
61100919	Long cleaning cards (50)
61100912	Adhesive cleaning roller (5)
61100918	Card cleaning cartridge

Appendix E Warranty Information

PRINTERS

NBS JAVELIN printers (excluding printhead) are warranted against defects in material or workmanship. Proof of purchase or shipment date is required to validate the warranty. This warranty is subject to normal usage and becomes void if the equipment is modified, improperly installed or used, damaged by accident or neglect, or if any parts are improperly installed or replaced by the user.

PRINTHEADS

The original printhead is covered by an unlimited number of passes warranty. The warranty period begins on purchase date. To qualify for this warranty, the printhead must be returned to NBS or to an authorised dealer. Customers are not required to purchase NBS supplies (media and/or ribbons) for warranty qualification. However, if it is determined that the use of other manufacturers' supplies has caused any defect in the printhead for which a warranty claim is made, the user is responsible for all charges required to repair the defect. The warranty becomes void if the printhead is physically worn or damaged; also if it is determined that failure to follow the preventive maintenance schedule listed in the user's manual has caused defects in the thermal printhead for which a warranty claim is made.

SUPPLIES

These are warranted to be free from defect in material and workmanship provided the user has complied with storage, handling and usage guidelines established for supplies used with NBS Javelin printers.

SPARE PARTS

All parts, maintenance kits, options kits, and accessories are warranted to be free of defects in material and workmanship. This warranty becomes void if the item is modified, improperly installed or used, or damaged by accident or neglect.

Notes: Failure to exercise caution to protect the equipment from electrostatic discharge damage, adverse temperature and humidity conditions or physical abuse, including, but not limited to, improper packaging, shipping, service or repairs performed by personnel not authorised by NBS or an authorised dealer may void the warranty. NBS or its authorised dealer will, at its option, repair or replace the equipment or any parts which are determined to be defective within this warranty period, and which are returned to NBS or its authorised dealer. NBS specifically disclaims the implied warranties of merchantability and fitness for a particular purpose. For full warranty terms, including the length of warranty period, please contact the Javelin dealer from whom you purchased your printer.

Appendix F Technical Support

If for any reason you require product technical support, please contact the distributor where you purchased your equipment. If they cannot help you, or at their direction, contact NBS.

For support in Europe, Middle East, Africa and Asia Pacific:

**NBS TECHNOLOGIES
7 BYFLEET TECHNICAL CENTRE
CANADA ROAD
WEST BYFLEET
SURREY KT14 7NB
UNITED KINGDOM**

**Tel: +44 1932 351531
Fax: +44 1932 351382**

Email: technical.support@nbstech.com.

For support in North and South America:

**NBS TECHNOLOGIES
10925 BREN ROAD EAST
MINNEAPOLIS MN 55343
UNITED STATES OF AMERICA**

**Tel: 1 800 565 9033 or
+1 (416) 840 8627
Fax: +1 (952) 912 9439**

Email: technical.support@nbstech.com

Web: www.nbstech.com

HOW TO RETURN YOUR PRINTER

If you have purchased your printer from an NBS distributor, please first contact them on their return procedures.

Alternatively, contact the appropriate NBS Technical support department (details above) for instructions before shipping your printer.



Only complete goods in their original packaging with a valid Returned Materials Advice (RMA) number clearly marked on the outside can be accepted for return to NBS.

Appendix G Declarations of Conformity



European Council Directive		Compliance to Standards	
89/336/EEC modified by 92/31/EEC and 93/63/EEC	EMC Directive	EN 55022-B	RF Emissions control
	EMC Directive	EN 500082-1, 1992	Immunity to Electromagnetic Disturbances
73/23/EEC modified by 593/68/EEC	Low voltage Directive	EN 60950	Product Safety



Model: J330i conforms to the following specification:
FCC Part 15, Subpart A, Section 15.107(a) and Section 15.109(a) Class A digital device

Supplemental Information:

This device complies with Part 15 of the FCC rules. Operation is subject to the following two conditions: (1) This device may not cause harmful interference, and (2) this device must accept any interference received, including interference that may cause undesired operation.

Note:

This equipment has been tested and found to comply with the limits for a class A digital device, pursuant to Part 15 of the FCC Rules. These limits are designed to provide reasonable protection against harmful interference when the equipment is operated in a commercial environment. This equipment generates, uses, and can radiate radio frequency energy and, if not installed and used in accordance with the instruction manual, may cause harmful interference to radio communications. Operation of this equipment in a residential area is likely to cause harmful interference in which case the user will be required to correct the interference at his own expense.

INDUSTRY CANADA NOTICE

This device complies with Industry Canada ICS-003 class A requirements.

TRADEMARKS

JAVELIN is a registered trademark of NBS Technologies. Windows and MS-DOS are registered trademarks of Microsoft Corp. All other marks are trademarks or registered trademarks of their respective holders.

COPYRIGHT NOTICE

This document contains information proprietary to NBS. This document and the information contained within is copyrighted by NBS and may not be duplicated in full or in part by any person without written approval from NBS. While every effort has been made to keep the information contained within current and accurate as of the date of publication, no guarantee is given or implied that the document is error-free or that it is accurate with regard to any specification. NBS reserves the right to make changes, for the purpose of product improvement, at any time.