

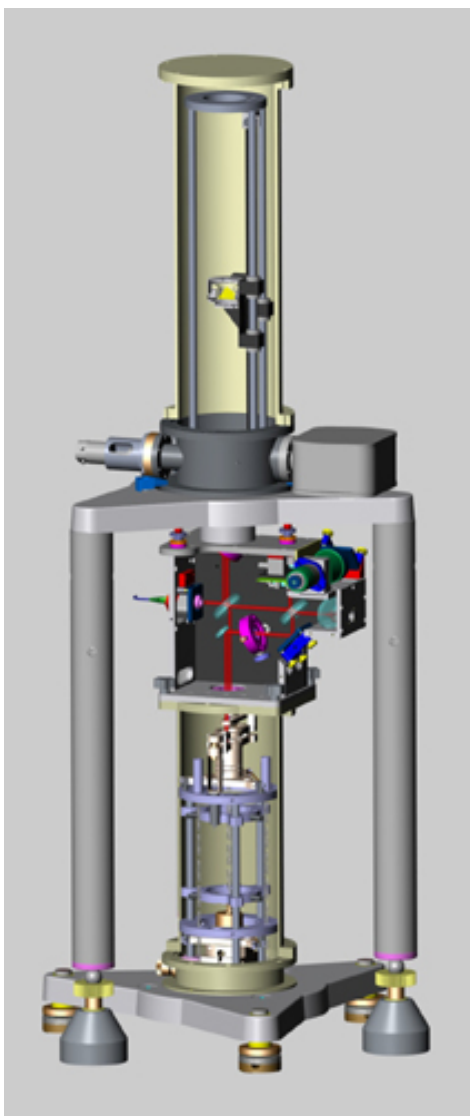

[WWW.MICROGLACOSTE.COM](http://WWW.MICROGLACOSTE.COM)

# FG5 Absolute Gravimeter User's Manual



DECEMBER 2006



# FG5 OPERATOR'S MANUAL

## TABLE OF CONTENTS

<b>TABLE OF FIGURES.....</b>	<b>5</b>
<b>1 INTRODUCTION.....</b>	<b>7</b>
1.1 HISTORY .....	7
1.2 THE FG5 ABSOLUTE GRAVIMETER.....	7
1.3 UNITS IN GRAVITATIONAL MEASUREMENTS.....	9
1.4 FG5 DESIGN FEATURES .....	10
<b>2 DETAILED THEORY OF OPERATION.....</b>	<b>11</b>
2.1 G DETERMINATION.....	11
2.2 DESIGN: HARDWARE COMPONENTS AND FUNCTION.....	12
2.3 DROPPING CHAMBER THEORY .....	14
2.3.1 <i>The Dropping Chamber</i> .....	14
2.3.2 <i>The Drag-free cart</i> .....	15
2.3.3 <i>The Service Ring</i> .....	17
2.3.4 <i>The Dropper Controller</i> .....	18
2.4 INTERFEROMETER THEORY .....	19
2.4.1 <i>Beam Verticality</i> .....	21
2.4.2 <i>Beam Alignment</i> .....	22
2.5 SUPERSPRING THEORY .....	24
2.6 LASER THEORY .....	27
<b>3 FG5 SETUP.....</b>	<b>29</b>
3.1 INSTRUMENT ASSEMBLY.....	29
3.1.1 <i>Electronics Case</i> .....	29
3.1.2 <i>Setting up the Superspring Tripod</i> .....	30
3.1.3 <i>Interferometer</i> .....	32
3.1.4 <i>Dropping Chamber Tripod</i> .....	33
3.1.5 <i>Leveling the Dropping Chamber</i> .....	33
3.1.6 <i>Cable Connections</i> .....	34
3.1.7 <i>The Superspring</i> .....	35
3.1.8 <i>DC Power On</i> .....	36
3.1.9 <i>Beam Verticality</i> .....	36
3.1.10 <i>Fringe Optimization</i> .....	37
3.2 SOFTWARE SET UP.....	39
3.2.1 <i>Information Setup</i> .....	39
3.2.2 <i>System Setup</i> .....	39



- 3.2.3 Acquisition Setup ..... 40
- 3.2.4 Control Setup ..... 40
- 3.3 RUNNING THE GRAVIMETER ..... 42
  - 3.3.1 Starting the Measurement ..... 42
  - 3.3.2 Data Quality..... 43
  - 3.3.3 Reprocessing Data ..... 43
- 3.4 SHUTTING DOWN THE FG5 ..... 44
- 4 ADJUSTMENT AND MAINTENANCE..... 46**
  - 4.1 SUPERSPRING ..... 46
    - 4.1.1 Removing the Superspring Cover ..... 46
    - 4.1.2 The Spring Position is off the Detector..... 46
    - 4.1.3 Superspring will not go to Zero ..... 47
    - 4.1.4 Gravity data shows very large Scatter or large Residuals ..... 48
    - 4.1.5 Alignment ..... 49
  - 4.2 DROPPING CHAMBER ..... 49
    - 4.2.1 Ion pump Issues..... 49
    - 4.2.2 Feedthrough Issues ..... 50
    - 4.2.3 Dropper Tuning Adjustments ..... 50
    - 4.2.4 Drive Belt Replacement ..... 51
    - 4.2.5 Dropper Alignment ..... 51
  - 4.3 THE LASER..... 54
    - 4.3.1 Laser Stability..... 55
    - 4.3.2 Laser Alignment..... 56
    - 4.3.3 5-Axis Mount..... 56
    - 4.3.4 Fiber polarization..... 57
- 5 VACUUM CHAMBER: TURBO PUMP AND BAKING OUT..... 59**
  - 5.1 SETTING UP THE TURBO PUMP ..... 59
  - 5.2 BAKING OUT THE DROPPING CHAMBER..... 61
    - 5.2.1 Heating the Chamber..... 61
  - 5.3 STARTING THE ION PUMP ..... 62
- 6 ELECTRONICS CONNECTIONS..... 64**
  - 6.1 SIM ..... 64
  - 6.2 MAGMA PCI UNIT ..... 64
  - 6.3 POWER SUPPLY ..... 64
- 7 GRAVITY SITE SELECTION ..... 65**
  - 7.1 GEOLOGIC STABILITY ..... 65
  - 7.2 SITE STABILITY ..... 65
  - 7.3 ENVIRONMENTAL NOISE ..... 65
  - 7.4 TEMPERATURE STABILITY ..... 65
  - 7.5 AC POWER..... 65
- 8 SYSTEM SPECIFICATIONS ..... 66**



8.1	POWER.....	66
8.2	WEIGHT AND DIMENSIONS XXXX .....	66
8.3	OPERATING TEMPERATURE.....	66
<b>9</b>	<b>WARRANTY.....</b>	<b>67</b>
<b>10</b>	<b>CHECKLISTS .....</b>	<b>68</b>
	SETUP .....	68
<input type="checkbox"/>	TEAR DOWN .....	70



## Table of Figures

FIGURE 1 DIRECT MEASUREMENT OF ABSOLUTE G. AS THE OPTICAL FRINGES GO THROUGH ZERO, THE PRECISE TIME IS RECORDED BY AN ATOMIC CLOCK. A LEAST-SQUARES FIT TO THE TIME AND DISTANCE PAIRS IS USED TO DETERMINE G. .... 9

FIGURE 2. THE FG5 SYSTEM. THE LASER, SYSTEM CONTROLLER, AND ELECTRONICS RACK ARE NOT SHOWN. .... 13

FIGURE 3. FRONT VIEW OF THE DROPPING CHAMBER ..... 14

FIGURE 4. SIDE VIEW OF DROPPING CHAMBER..... 15

FIGURE 5. FRONT VIEW OF THE CART/DROP-FREE CHAMBER..... 16

FIGURE 6. SIDE VIEW OF THE SERVICE RING ..... 17

FIGURE 7. BEAM PATH IN FG5 INTERFEROMETER. THE REFERENCE BEAM PASSES STRAIGHT THROUGH THE FIRST SPLITTER AND IS THEN SPLIT AGAIN TO ENTER THE DETECTOR AND THE OPTICAL DEVICES FOR ALIGNMENT. THE TEST BEAM LEAVES VERTICALLY FROM THE FIRST SPLITTER, TRAVELS THROUGH THE DROPPER AND SUPERSPRING, AND IS RECOMBINED WITH THE REFERENCE BEAM AT SPLITTER #2. NOTE THAT ONLY THE TELESCOPE AND NOT THE FRINGE WINDOW (VIEWPORT) IS SHOWN IN THE FIGURE. .... 20

FIGURE 8. SCHEMATIC OF FG5 INTERFEROMETER..... 21

FIGURE 9. BEAM VERTICALITY CONFIGURATION. THE ANGLE OF THE LASER LIGHT OUT OF THE FIBER IS ADJUSTED UNTIL THE REFERENCE AND TEST BEAMS (REFLECTED OFF THE SURFACE OF THE ALCOHOL POOL) APPEAR AT THE EXACT SAME LOCATION IN THE TELESCOPE..... 22

FIGURE 10. SUPERSPRING SCHEMATIC..... 25

FIGURE 11. SUPERSPRING/INTERFEROMETER SETUP ..... 31

FIGURE 14. IF THE LED LIGHT IS OFF OF THE DETECTOR, THE SPHERE POSITION WILL READ ABOUT ZERO VOLTS. AS THE LIGHT IS BROUGHT ON THE DETECTOR, THE VOLTAGE APPEARS TO GO THE “WRONG” WAY. KEEP MOVING THE SPRING POSITION UNTIL IT IS ABOUT THE “TRUE” ZERO VALUE..... 47

FIGURE 12. BENT SUPERSPRING FLEXURE. THE SMALL WIRE AND THE BRASS PORTION OF THE FLEXURE SHOULD BE PARALLEL..... 48

FIGURE 13. USING A FEELER GAUGE TO MONITOR THE GAP SPACING ON THE SUPERSPRING GUIDE PINS..... 49

FIGURE 14. CHARACTERISTIC RESIDUALS SIGNAL WHEN THE VACUUM IS POOR. NOTE THE VERTICAL SCALE IS ABOUT 10X LARGER THAN NORMAL..... 50

FIGURE 15. CHAMBER ALIGNMENT. PLOT 1 SHOWS POOR ALIGNMENT . PLOT 2 SHOWS THE DROPPING CHAMBER TILTED SUCH THAT THE CART POSITION AT THE BOTTOM OF THE DROP IS DIRECTLY BELOW THE TOP OF THE DROP. NOTE THAT, IN GENERAL, THE TILT OF THE CHAMBER IS NOT NECESSARILY VERTICAL. ALSO, THE TILT AND ROD-BEND HAVE BEEN GREATLY EXAGGERATED..... 52

FIGURE 16. USING THE X-Y DETECTOR TO SET DROPPING CHAMBER BUBBLE LEVELS. IN GENERAL, AS THE CART IS LIFTED UP AND DOWN, IT WILL ALSO MOVE SLIGHTLY SIDWAYS. THUS, THE REFLECTED LASER BEAM WILL APPEAR TO TRANSLATE. TILT THE CHAMBER UNTIL THE POSITION OF THE REFLECTED BEAM AT THE TOP OF THE DROP IS THE SAME AS AT THE BOTTOM OF THE DROP. THEN SET THE BUBBLE LEVELS TO READ ZERO. AGAIN THE ROD BEND AND TRANSLATION ARE EXAGGERATED..... 53



FIGURE 17. LOCATION OF THE DROPPER TRIPOD ADJUSTABLE FEET. BY ADJUSTING THE HEIGHT OF THESE 3 FEET, THE TILT OF THE DROPPING CHAMBER CAN BE MADE TO MATCH THAT OF THE SUPERSPRING..... 54

FIGURE 18. TURBO PUMP CONNECTED TO DROPPING CHAMBER. NOTE THE MINIMUM STRESS IN THE HOSE. .... 60



# 1 INTRODUCTION

## 1.1 *History*

A ballistic absolute gravimeter works by dropping an object in a vacuum and measuring the time it takes to fall a specified distance. Galileo recognized that the acceleration of a freely falling body is independent of its mass, and legend has it that he demonstrated this by dropping objects of different weight from the leaning tower of Pisa (though this may be apocryphal). Newton's theory of gravitation also required that the acceleration of a falling body in an external gravity field did not depend on its size, shape, or mass. Thus, measuring the acceleration of a freely falling object is equivalent to measuring gravity. This freefall acceleration is given the special symbol,  $g$ , to remind us that gravity is responsible.

The FG5 represents the latest generation of ballistic absolute gravimeters and is based on technology developed over the last forty years by Dr. James Faller of the National Institute of Standards and Technology (NIST) and his colleagues. Beginning with a white-light-fringe interferometric system built in 1962, Faller and coworkers have continuously improved the designs of the instruments. The most recent predecessors of the FG5 were the six JILAg gravimeters, built in 1985 at the Joint Institute of Laboratory Astrophysics (JILA), with support from NIST, the Defense Mapping Agency (DMA), the National Oceanographic and Atmospheric Administration (NOAA), the Canadian Geophysical Survey (GSC), the University of Hanover Institute for Earth Measurement, Germany, the Finnish Geodetic Institute, Finland, and the University of Vienna Institute for Metrology and Geophysics, Austria.

The FG5 is now a firmly established standard in the fields of geophysics and metrology. As of 2006, over 45 instruments have been constructed and are employed throughout the world.

## 1.2 *The FG5 Absolute Gravimeter*

The FG5 absolute gravimeter is a high precision, high accuracy, transportable instrument that measures the vertical acceleration of gravity. The operation of the FG5 is simple in concept: A test mass is dropped vertically by a mechanical device inside a vacuum chamber, and then allowed to fall a distance of about 20 cm. A laser interferometer is used to determine the position of the test mass as a function of time during its freefall. The acceleration of the test mass is calculated directly from the measured trajectory.



The interferometer generates an optical interference fringe each time the test mass falls  $\frac{1}{2}$  the wavelength of the laser light. These fringes are counted and timed with an atomic clock to obtain precise time and distance pairs. A least-squares fit to these data are used to determine the value of  $g$ . This method of measuring gravity is *absolute* because the determination is purely metrological and relies solely on standards of length and time. The distance scale is given by a frequency stabilized helium neon (HeNe) laser used in the interferometer. A rubidium atomic time-base provides the accurate time scale. The value of gravity obtained with the FG5 can be used without the loop reductions and drift corrections normally required when using relative instrumentation. With the FG5, the absolute gravity value is determined and reported immediately.

Figure 1 shows how gravity is measured with an FG5. A test body, containing a corner cube retro-reflector, is dropped from the top of the dropping chamber. The laser light is split to reflect off the falling corner cube and a fixed corner cube which serves as a reference. The mass accelerates to the bottom of the chamber, and the raw fringe signal is detected by the photodiode as the dropped object falls. The optical fringes in the raw fringe signal are timed to create calibrated time and distance pairs. The lower part of the figure demonstrates the increase in the fringe signal frequency as the test body accelerates.



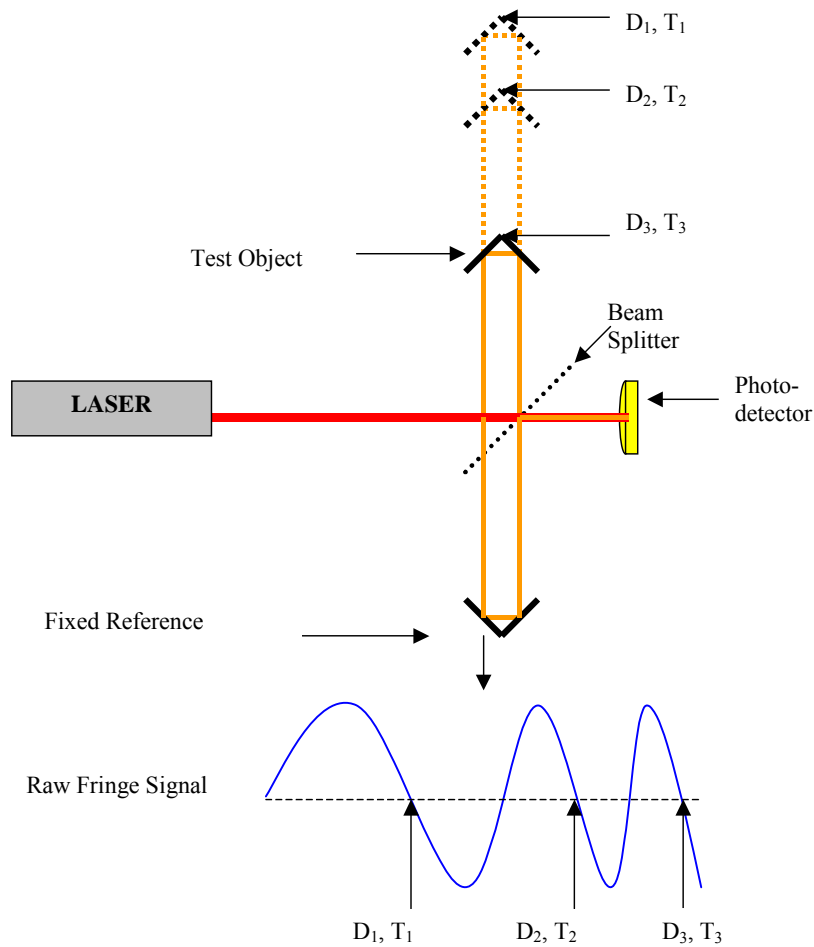

**Figure 1 Direct Measurement of Absolute g.** As the optical fringes go through zero, the precise time is recorded by an atomic clock. A least-squares fit to the time and distance pairs is used to determine g.

### 1.3 Units in Gravitational Measurements

g is defined to be the magnitude of the acceleration experienced by a freely falling body at a specified point. As such, it is simply a scalar and is reported in units of distance per squared time interval. In the S.I. system of units, gravity is nominally about  $9.8 \text{ m/s}^2$ .

For historical reasons, gravity is also commonly reported in the CGS system of units. This CGS unit of  $1\text{cm/s}^2$  is given the name Gal after the famous father of gravity, Galileo. Using these units, the nominal gravity is 980 Gal. Precision gravity measurements are often given in units of micro-gals:  $1 \mu\text{Gal} = 10^{-6}\text{Gal}$ . A measurement resolution of 1 micro-Gal ( $\mu\text{Gal}$ ) therefore requires a measurement of the earth's field with a precision of 1 part in  $10^9$  (1 part/billion). Another



common gravity unit used in field measurements of gravity is the mGal (1 mGal = 1000  $\mu$ Gal).

$$1 \mu\text{Gal} = 10^{-6} \text{Gal.}$$

$$\text{The conversion between } \mu\text{Gal and SI units is } 1 \mu\text{Gal} = 10^{-8} \text{ m/s}^2.$$

## 1.4 FG5 Design Features

The FG5 incorporates a number of significant advancements over previous designs which reduce or eliminate systematic errors identified in the earlier versions. These improvements are:

- Enhanced electronics reflect newer technology and make the instrument smaller and easier to use.
- This absolute gravimeter is designed to work with iodine-stabilized laser systems (WEO models 100 and 200) traceable to the BIPM primary standards.
- The system controller has been updated to a standard, Intel-based laptop computer.
- “g”, a user-friendly, Windows©-based, full-featured software program is used for data acquisition. This software provides an immediate value for the local gravity in real-time. The program is also a full-featured post-processing software program that allows complete ability to vary data analysis procedures and to vary environmental corrections.
- An optional “remote operation” package is available that allows virtually complete remote control of the instrument and the software via an internet connection.



## 2 DETAILED THEORY OF OPERATION

### 2.1 *g* Determination

As mentioned in the Introduction, the FG5 determines the acceleration of gravity,  $g$ , by using an interferometer to accurately track a test mass during freefall in a vacuum. The photodetector circuit at the output of the interferometer produces a pulse each time this interference signal crosses zero, and the times of these pulses are measured precisely using a rubidium clock. In the simplest example, these time and distance pairs could then be used to find a least-squares solution to the following equation:

$$x_i = x_0 + v_0 t_i + \frac{1}{2} g_0 t_i^2,$$

where  $x_0$ ,  $v_0$ , and  $g_0$  are free parameters providing the best estimates for the initial position, velocity, and gravity, respectively. Of course,  $g$  is the parameter of most interest! In practice however, the situation is a bit more complicated. The finite value of the Earth's gravity gradient,  $\gamma$  (approximately  $-3 \mu\text{Gal/cm}$ ) causes a measurable change in  $g$  over the small length of the drop, and this complicates this "standard" equation:

$$x_i = x_0 + v_0 t_i + \frac{1}{2} g_0 t_i^2 + \frac{\gamma x_0 t_i^2}{2} + \frac{\gamma v_0 t_i^3}{6} + \frac{\gamma g_0 t_i^4}{24}.$$

In principle, the gradient should be a free parameter as well, but the short length of the drop provides little sensitivity in its determination. Therefore in practice, the gradient at the measurement location is either estimated or measured separately and entered into the software (see the  $g$  Software User's Manual for details). For reference, the "free air" value of the gradient is  $-3.086 \mu\text{Gal/cm}$ .

Finally, because the arm of the interferometer that reflects off the test mass gets shorter during the drop, and because the speed of light is not infinite, the fringes at the bottom of the drop will arrive "sooner than they should". The equation thus has to be further modified as:

$$x_i = x_0 + v_0 \tilde{t}_i + \frac{1}{2} g_0 \tilde{t}_i^2 + \frac{\gamma x_0 \tilde{t}_i^2}{2} + \frac{\gamma v_0 \tilde{t}_i^3}{6} + \frac{\gamma g_0 \tilde{t}_i^4}{24},$$

where  $\tilde{t}$  is the retarded time given by,

$$\tilde{t}_i = t_0 - \frac{(x_i - x_0)}{c}.$$



The gravity value determined from a least-squares fit to the above equation is thus the best estimate for the absolute value of  $g$  at the beginning (top) of this particular measurement (or “drop”). Usually this number is recalculated at a more convenient height (perhaps for future comparison), and corrections are made for things like earth tide, ocean loading, polar motion, current changes in barometric pressure. These corrections and their applications are discussed in the  $g$  Software User's Manual.

## ***2.2 Design: Hardware Components and Function***

The FG5 System (Figure 2) consists of a Dropping (or Vacuum) Chamber, Interferometer Base, Superspring, Laser, System Controller, and Electronics. The test mass is allowed to free-fall inside the evacuated Dropping Chamber. The Interferometer Base (or “IB”) is used to monitor the position of the freely-falling test mass. The Superspring is an active long-period isolation device used to provide an inertial reference for the gravity measurement. The System Controller (computer) allows a flexible user interface, controls the system, acquires data, analyzes data, and stores the results. The Electronics provides high accuracy timing necessary for the measurement and provides system servo control. Each component is discussed in detail below.

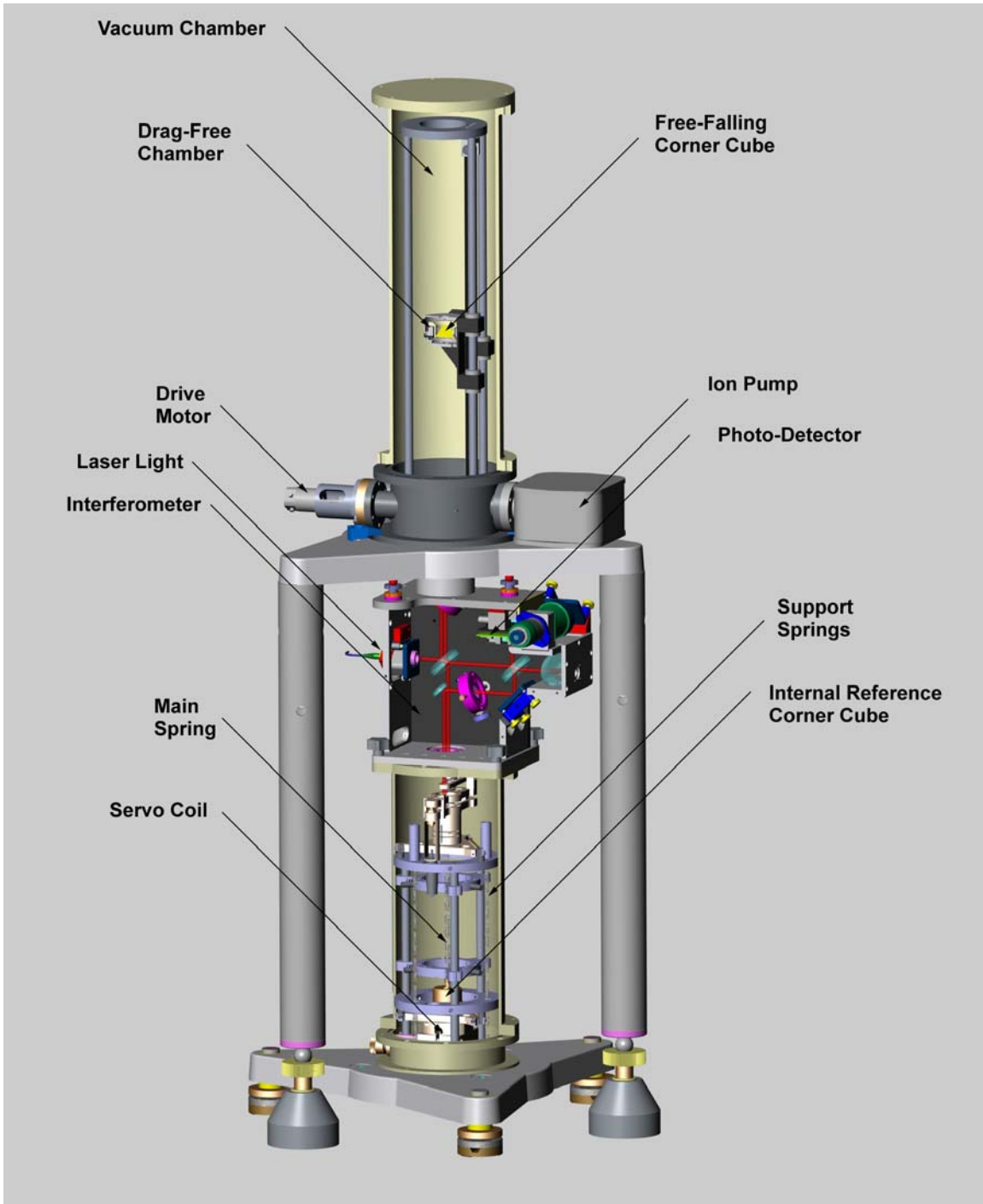

Figure 2. The FG5 System. The laser, system controller, and electronics rack are not shown.



## 2.3 Dropping Chamber Theory

### 2.3.1 The Dropping Chamber

The Dropping Chamber is an evacuated chamber which contains a drag-free cart which, in turn, houses the test-mass/corner-cube. Figure 3 shows a schematic. A drive mechanism is used to drop, track, and catch the test mass inside the drag-free cart. Laser light passes through a window in the bottom of the Dropping Chamber to the corner cube (inside the test mass), and is then reflected back down through the window to the interferometer.

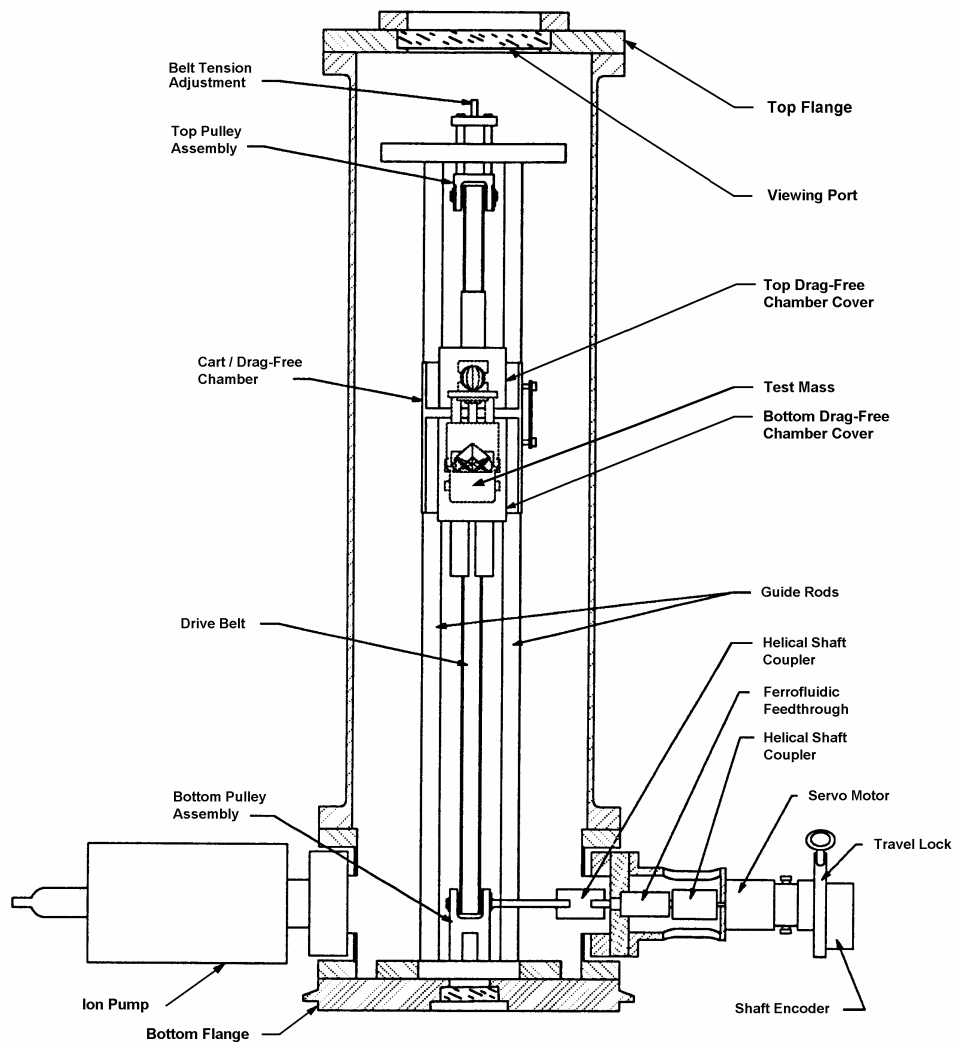

Figure 3. Front view of the dropping chamber

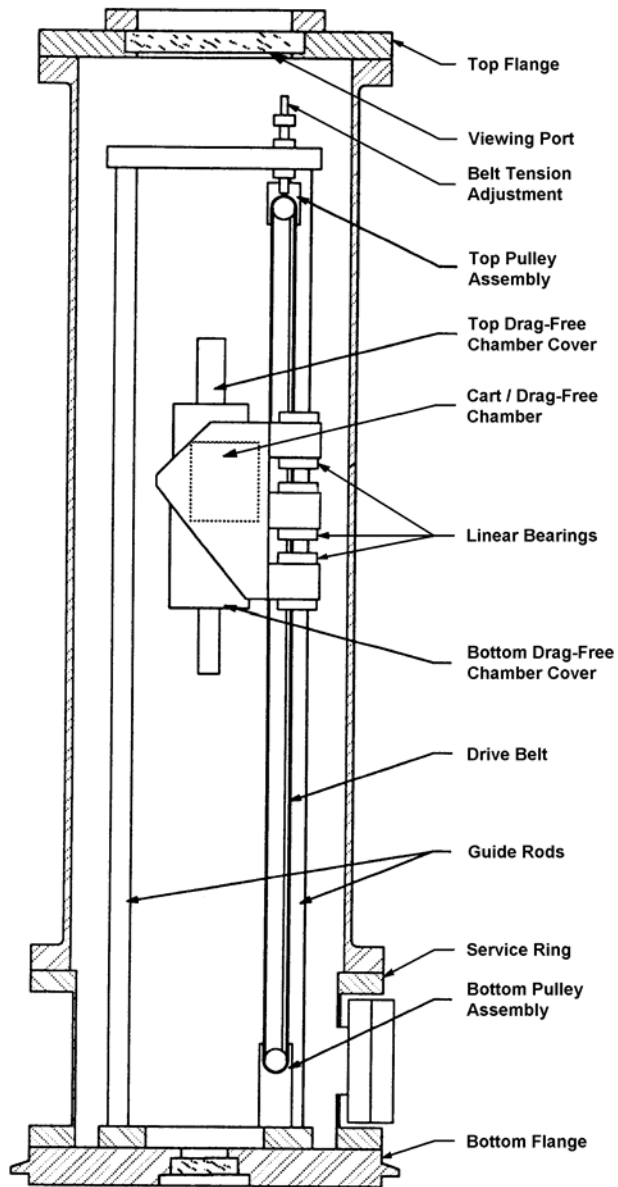
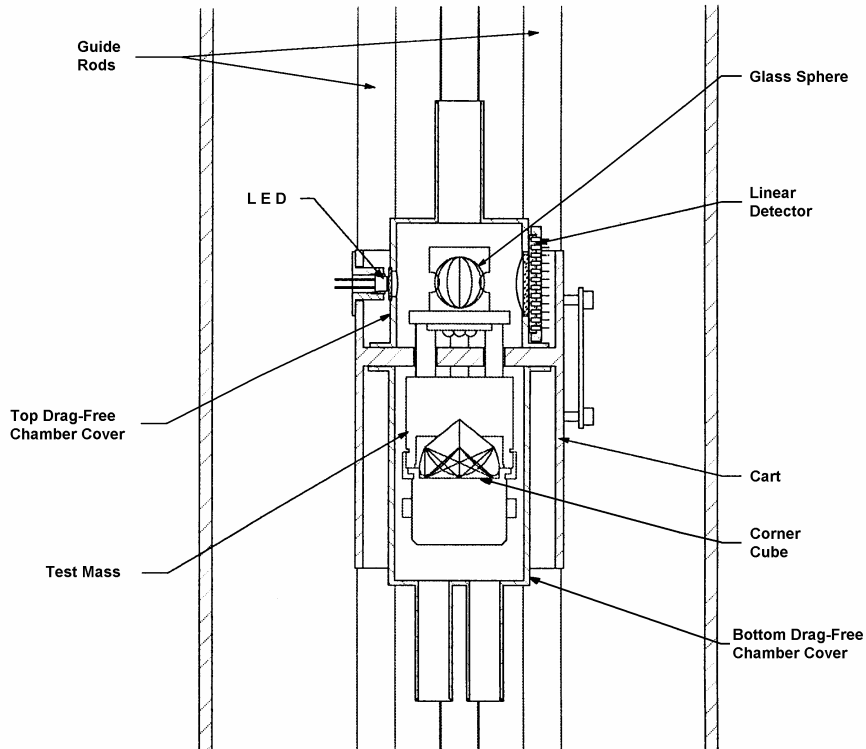

Figure 4. Side view of dropping chamber

### 2.3.2 The Drag-free cart

The drag-free cart is used to lift, drop, and catch the test mass. The term “drag-free” refers to the fact that though the chamber is evacuated, there are still some residual air molecules. The cart effectively pushes these molecules out of the way of the test mass, which is falling inside the cart. In addition to reducing drag, the cart also reduces magnetic and electrostatic forces on the test mass.



**Figure 5. Front view of the cart/drag-free chamber.**

The test mass contains a retro-reflective corner-cube surrounded by a support structure which is balanced at the optical center of the corner-cube. The corner-cube is a three-surface mirror which has the special optical property that the reflected beam is always parallel to the incident beam. In addition, the phase shift of the reflected beam is virtually constant with respect to any slight rotation or translation of the corner cube around its optical center. When in contact with the cart, the test mass is supported by three spherical feet (or “balls”) that fit and orient it to “vees” in the cart.

The drive mechanism is a support structure inside the dropping chamber on which the cart/drag-free chamber travels up and down, and is driven by a DC servo motor. The cart is attached to a belt that is driven up and down by a shaft attached to the motor. The motor is located outside of the chamber is connected to the shaft via a ferrofluidic feedthrough (this device allows the vacuum to be maintained inside the chamber while a shaft rotates through the wall). The motor also turns an optical shaft encoder that provides accurate information to the dropper controller on the position and velocity of the pulley.

At the beginning of a drop, the cart accelerates downwards with an acceleration greater than  $g$  allowing the test mass to begin freefall. Once a certain separation (typically about 3 mm) between the cart and the test mass is reached, the cart slows





down and then tracks the test mass, maintaining a constant separation of a few millimeters. Finally, at the bottom of the drop, the cart gently catches the test mass and decelerates to a stop.

The tracking during the drop is accomplished by a sophisticated servo system that works as follows: By keeping track of the cart position using a shaft encoder on the belt drive pulley, and using the interferometer (fringes) to establish the object position, the distance between the cart and the mass can be derived. During freefall, this separation is maintained at a constant distance by using a servo-motor drive system to control the cart inside the Dropping Chamber. Because there is essentially no relative motion between the test mass and the drag-free chamber, the effects of residual air drag are eliminated.

### 2.3.3 The Service Ring

The Service Ring (Figure 6) is at the base of the Dropping Chamber. It provides connections and mounting for the following:

- A bellows-type vacuum valve for the initial evacuation of the vacuum system
- A Ferrofluidic rotary vacuum feedthrough which connects the motor shaft to the cart drive mechanism
- A servo motor/rotary shaft encoder assembly which moves the cart and senses its position
- An ion pump, mounted on a 2<sup>3</sup>/<sub>4</sub>" Conflat flange, which maintains the vacuum once the chamber has been evacuated by the roughing pump
- Spare 2<sup>3</sup>/<sub>4</sub>" Conflat and Mini-Conflat flanges are blanked off, and can be used for additional vacuum accessories

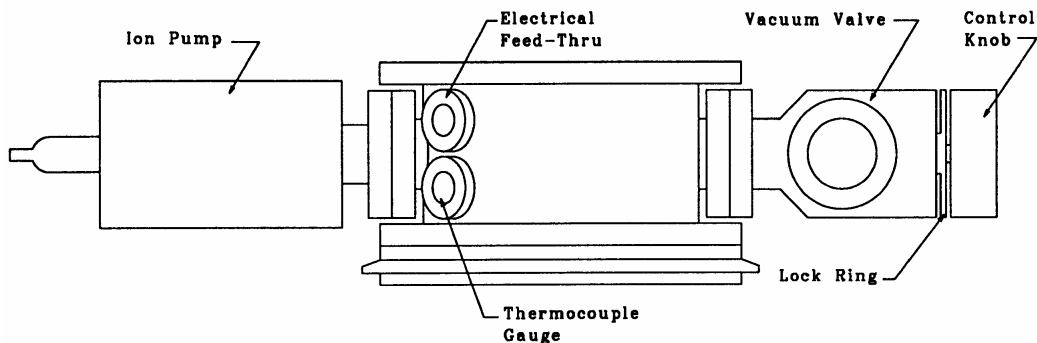

Figure 6. Side view of the service ring



### 2.3.4 The Dropper Controller

The dropper controller is the servo circuit that controls the motor that drives the cart. Located in the SIM (please the SIM User's Manual for more information), it is also the interface between the user and the dropping chamber.

The controller can be operated in two modes: OSC and DROP. The operator controls the status of these modes and the dropper triggering with the RESET switch and the TRIGGER switch.

In DROP mode, a single trigger causes the controller to drive the motor to lift the cart (and test mass) to a specified height. An additional trigger then initiates the drop sequence: the cart pulls away with an acceleration greater than  $g$ , and then tracks the test mass (maintaining a specified separation distance) during free-fall, and finally softly catches the test mass at the bottom. If a TTL pulse is entered into EXT TRIG this will also cause a lift, and a separate pulse will cause the drop. These are normally supplied by the computer during data acquisition. To exit DROP mode, press RESET. The controller is now insensitive to triggers.

OSC (oscillation) mode is used to slowly raise and lower the cart (the object is never in freefall) to create slow and constant interference fringes. The magnitude of this fringe signal is used for system alignment purposes (see Setup information in Section 3.1.10). To initiate OSC mode, first make sure the dropper is un-travel-locked, and then press OSC. You should see the position LEDs on the front of the SIM indicate a slow movement of the cart. To stop OSC mode, press the TRIGGER button at any time. The cart will automatically stop at the bottom of the next oscillation cycle (Alternatively, you can press DROP, and this will place the controller in DROP mode at the bottom of the next oscillation cycle). Take care not to hit the RESET button directly, as this will immediately (and roughly!) drop the test mass and cause excessive wear on the 'balls' and 'vees'.



## 2.4 Interferometer Theory

Refer to Figure 7 and Figure 8 for the following descriptions of the beam path. The optical fiber directs the laser light from the laser head to the interferometer base. At the input of the interferometer, a lens collimates the light from the optical fiber. It is then directed to Beamsplitter #1, where it is split into the *test beam* and the *reference beam*. The reference beam is split again at Beamsplitter #2 and travels to the Avalanche Photo Diode (APD) and the fringe viewer. Note that the path length of the reference beam remains constant.

The test beam is reflected vertically at beamsplitter #1, and passes through a compensator plate and a window in the bottom of the Dropping Chamber. It is then reflected back down by the corner cube in the test mass. The test beam returns through the window, the compensator plate, and passes down through the interferometer base to the Superspring. The test beam passes through the top window of the Superspring chamber to the corner cube in the Superspring mass. From here, the test beam is reflected back up out of the Superspring and into the interferometer base, where it reflects off Mirror #1 (or the “pick off mirror”), passes through the translator plate (“twiddler”), reflects off Mirror #2, and is recombined with the reference beam at Beamsplitter #2.

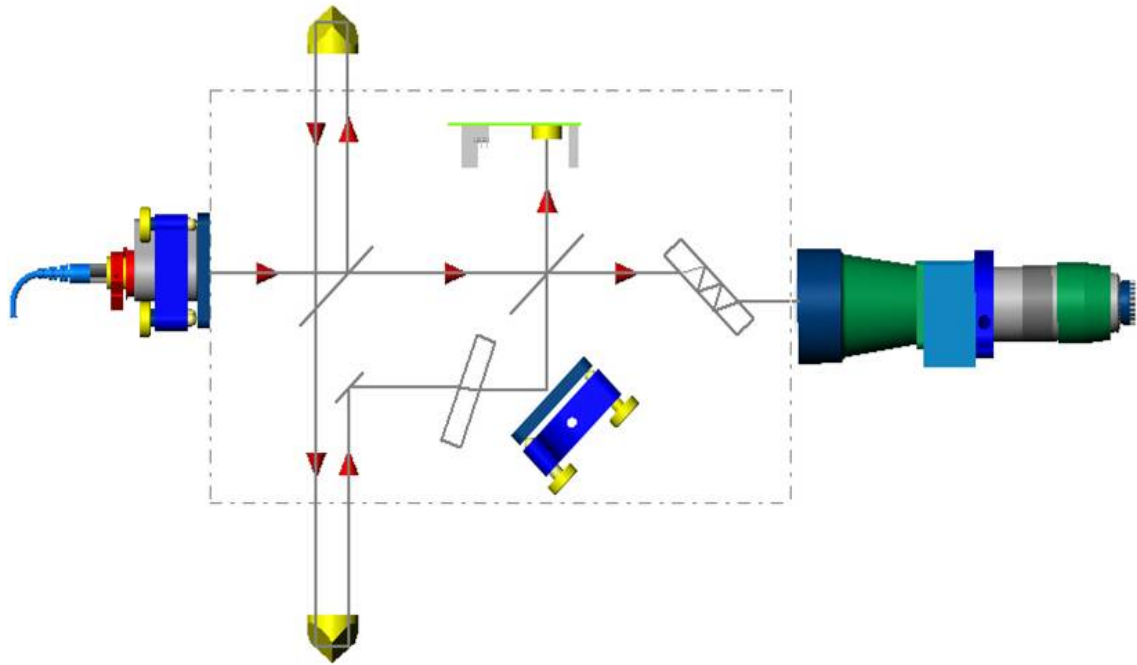

**Figure 7. Beam path in FG5 interferometer. The reference beam passes straight through the first splitter and is then split again to enter the detector and the optical devices for alignment. The test beam leaves vertically from the first splitter, travels through the dropper and Superspring, and is recombined with the reference beam at splitter #2. Note that only the telescope and not the fringe window (viewport) is shown in the figure.**

This interferometer is of the Mach-Zender type, with a fixed (reference) arm and a variable (test) arm. During a drop, the motion of the test mass affects the path length of the test beam. The interference fringes which result from the recombination of the test beam and the reference beam provide an accurate measure of the motion of the test mass relative to the mass suspended on the Superspring.

The two beams are recombined at Beamsplitter #2 and then split again. One set is focused by a lens to strike the detector (APD). The interference fringes are converted to an Analog signal and a Transistor-Transistor Logic (TTL) signal which is transmitted to the time interval analyzer card in the system controller.



The other recombined beam set travels horizontally until it reaches the attenuator plate (“rattler”). This beam is split yet again and reflects between the beamsplitter coating and the uncoated side of the attenuator plate. Three beams of decreasing intensity emerge from the coated side. The first and brightest of these beams travels horizontally into the fringe viewer. The second and third beams are deflected vertically by a mirror. A flag in front of the mirror blocks the second beam, allowing the third (dimpest) beam to exit the interferometer where it is reflected off Mirror #3 and enters the collimating telescope.

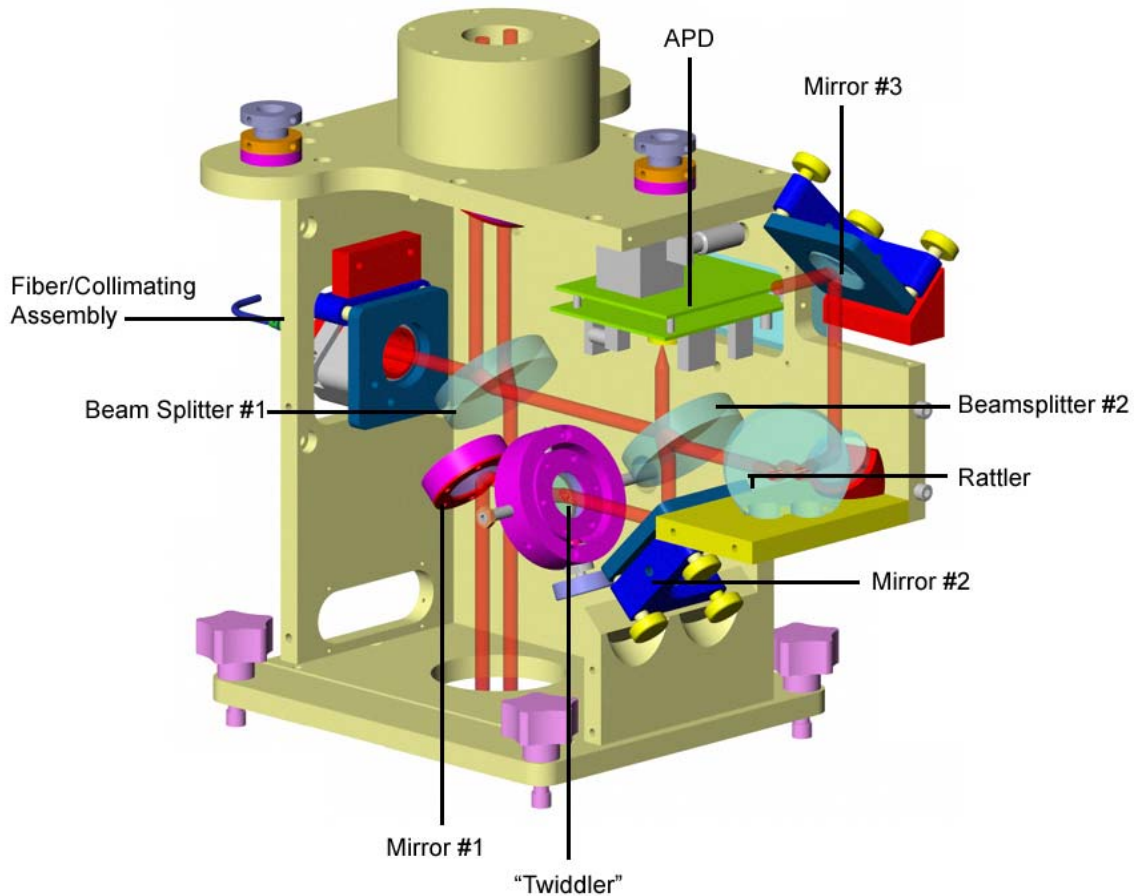

Figure 8. Schematic of FG5 interferometer

### 2.4.1 Beam Verticality

Because a non-vertical laser beam in the dropping chamber will always result in a gravity estimate that is too low (an error of 9 arcsec in verticality corresponds to a gravity value error of approximately  $-1 \mu\text{Gal}$ . The error increases as  $-\theta^2$ ), it is critical to align the beam with the local vertical as accurately as possible. To provide a local reference standard, a pool of alcohol is inserted in the interferometer. In this configuration, the test beam reflects directly off the surface



of the liquid and back up to the first beam splitter. Only when the beam is truly vertical will the beam reflect back directly through itself, reflect off the bottom of beam splitter #1, and be parallel to the reference beam. The telescope is focused precisely to infinity, and thus parallel rays are focused to the same point in the view finder. By adjusting the input angle of the laser fiber (left side of Figure 9), the reference and test beams can be made to coincide in the telescope, and this can only happen when the beam is perfectly vertical.

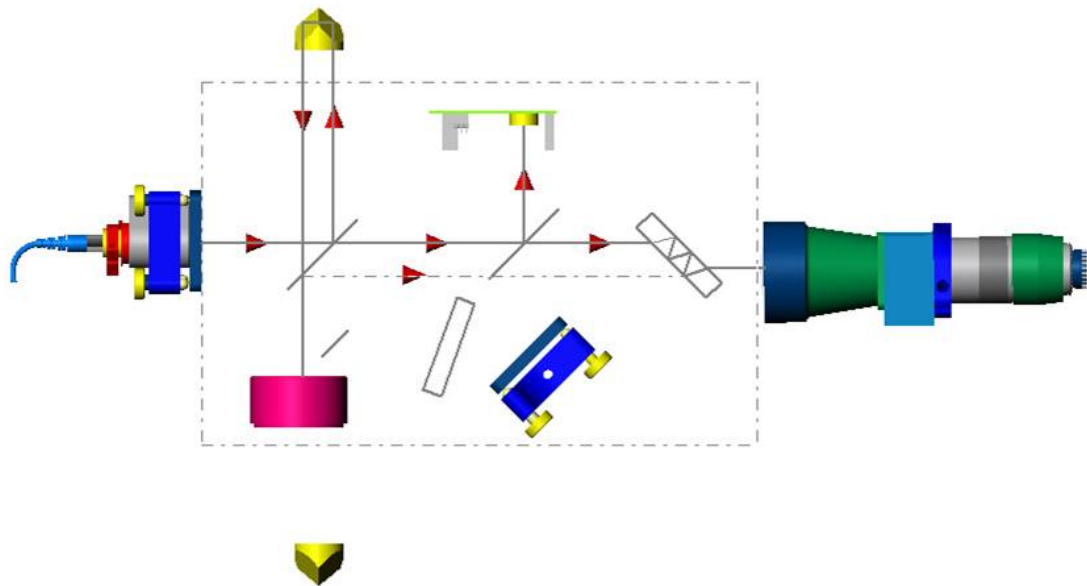

**Figure 9. Beam Verticality Configuration.** The angle of the laser light out of the fiber is adjusted until the reference and test beams (reflected off the surface of the alcohol pool) appear at the exact same location in the telescope.

### 2.4.2 Beam Alignment

In addition to making the test beam perfectly vertical, the user must also optimize the beam alignment. Because this procedure maximizes the interference fringe amplitude, this is often referred to as “fringe optimization”. The configuration of the Mach-Zehnder interferometer is such that it gives the user complete freedom to make the test and reference beams perfectly coincident and collinear at the detector. Please see Section 3.1.10 for detail on the setup steps.

The tipping plate is adjusted to translate the test beam so as to be coincident with the reference beam. This is best viewed in the viewport at the end of the interferometer



(not the telescope). By tilting the tipping plate about its horizontal and/or vertical axis, the test beam is simply translated relative to the (fixed) reference beam. Note that the angle of the test beam is not changed. This should be adjusted so that the reference beam is perfectly coincident with the reference beam in the viewport.

In addition, the angle of the test beam can be changed using mirror #2, below the telescope. This should be adjusted so that the test beam is perfectly overlapped with the reference beam in the telescope. Again, when two points meet at the same point in the telescope, they are parallel.

When the test and reference beams are truly collinear after beamsplitter #2, concentric "bull's eye" fringe patterns will be visible in the viewport window. Good overlap should also be quantitatively verified using an oscilloscope to view the interferometer's Analog output and measuring the peak-to-peak voltage of the fringe signal. Again, see Section 3.1.10 for detailed set up procedures.



## **2.5 *Superspring Theory***

The Superspring (Figure 10) is a long-period, active vertical isolator used to compensate for small vertical motions of the first beam splitter. The Superspring has a short (20 cm) mainspring with a natural period of about 1 second. The mainspring is contained in a support housing (also supported by springs) that is actively servo-controlled to track the Superspring mass at the end of the mainspring. The result is a long-period (30-60 second, or 16-30 mHz), spring-mass system that isolates against ground motions occurring at a higher frequency than its own enhanced natural frequency. This insures that any change in the length of the test beam is due only to the acceleration of the dropped object.



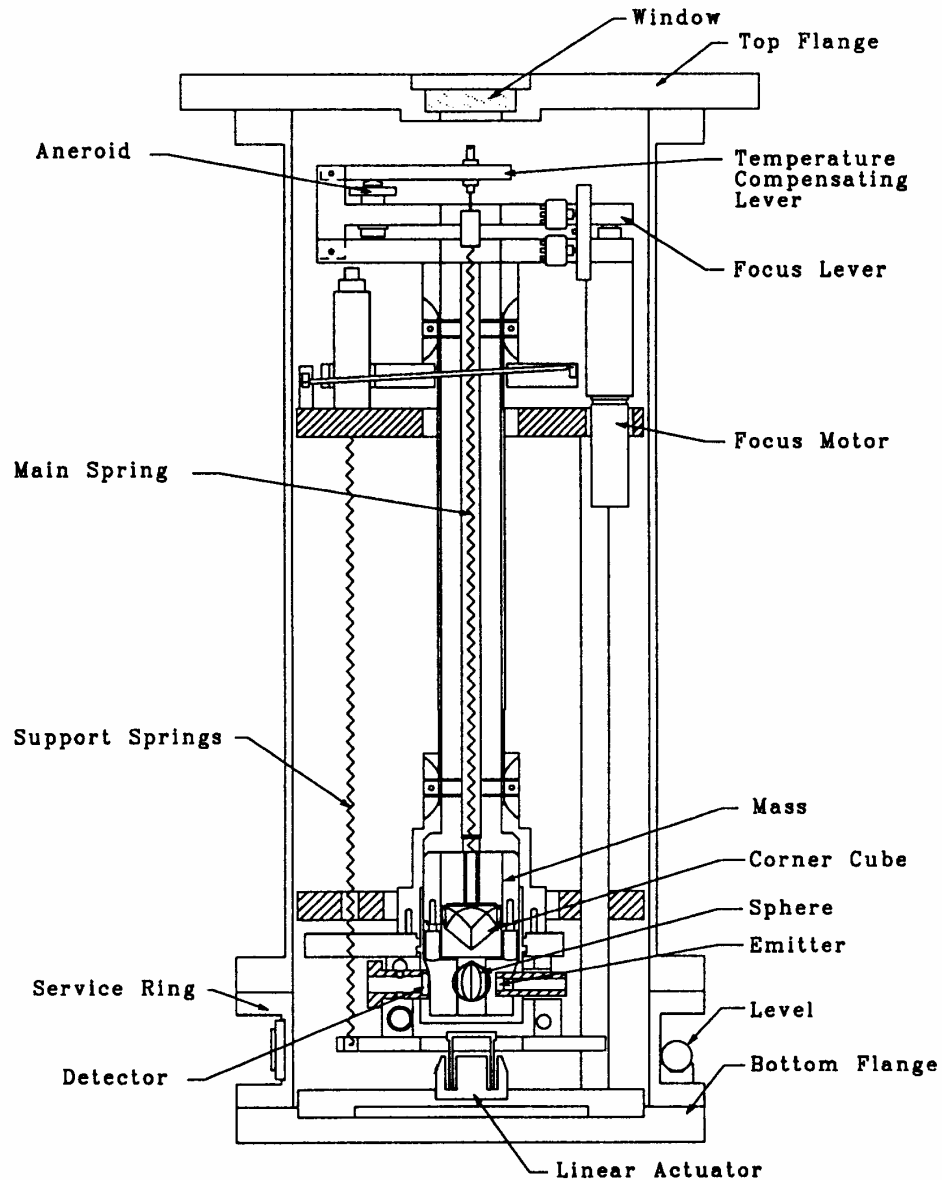

**Figure 10. Superspring schematic**

The servo mechanism works as follows. The Superspring sphere detector system senses motions of the Superspring mass relative to the inner support housing. An infrared LED located on the support housing directs light through an optical glass sphere attached to the Superspring mass. The sphere focuses this light onto a split photodiode detector mounted on the opposite side of the support housing. This signal from the split detector is fed back to a servo circuit which drives the support housing vertically, canceling any relative motion between the test mass and the inner housing. The drive mechanism is a linear coil actuator mounted between the support housing and the Superspring base. So as vertical ground motion occurs, the linear actuator moves the support housing up or down in such



a way as to keep the main spring length constant. This active servo effectively weakens the main spring, synthesizing a long period isolation device. The apparatus is constrained to move only vertically by a linear system constructed of five flexures (delta rods) arranged in an upper V-shaped array, and a lower triangular array.

The servo circuit is activated by turning SS SERVO on with the FG5 System Interface Module ("SIM" – please see the separate SIM User's Manual for more information). Note that if SS SERVO is off and the spring is un-travel-locked, the spring is just hanging freely and bouncing with the system's natural frequency (about 1 Hz).

The Superspring system also contains a DC motor that is used to center the test mass vertically in its range---"zeroing the spring" (as described in the Setup instructions, Section 3.1.7). This motor is activated by turning SS ZERO ON with the SIM controller. By monitoring the SS POS connector with a voltmeter, one can see the position approach 0 V – indicating that the mainspring is in the center of its range. Note that if the gravimeter has moved to a location with a drastically different local gravity value than the previous measurement location, it might take a few minutes for the spring to get to this zero position. This is normal. Finally, though it will not cause permanent damage to the system, it is best not to zero the Superspring with the servo activated.



## 2.6 Laser Theory

The FG5 employs a stabilized helium-neon laser to provide an accurate and stable wavelength used in the interferometric measurement system. There are three lasers which are currently available for the FG5. Please see the user's manual appropriate to the laser type that shipped with your FG5 system.

- The Winters Electro-Optics Model 100 iodine stabilized laser. This laser is a primary standard for the definition of the meter at the Bureau International des Poids et Mesures (BIPM) in Sevres, France. It is a highly stabilized frequency standard (trivially converted to a distance standard in a vacuum) having an absolute frequency accuracy of 1 part in  $10^{10}$  (50 kHz).
- The Winters Electro-Optics Model 200 iodine stabilized laser. This laser is based on the 100 model, but iodine-stabilized laser is used to lock a second, more powerful laser to the same frequency. The result is a more robust output.
- The Micro-g LaCoste Model ML-1 frequency/intensity stabilized HeNe laser is characterized by a slow, linear drift. Unlike the WEO lasers, it must be periodically calibrated to achieve the best accuracy, but it is more rugged and powerful.

All models of lasers need to be warmed up and reach thermal equilibrium before gravity data are acquired. As a rule of thumb, it is best to power on the laser the night before measurements, if possible. At a minimum the lasers should be on at least 1-4 hours for good results.

Again, regardless of the laser model, the light is always linearly polarized and reaches the interferometer via a single mode, polarization-maintaining fiber optic cable. The fiber polarization is set to match that of the laser light at the factory – under normal operations, it is never necessary to adjust the rotation at the input of the fiber.

The light enters the fiber optic cable via a 5-axis mount that focuses the light down to a diameter of a few microns. This adjustment is also done at the factory and is extremely sensitive. The laser light exits the fiber and diffracts at a well defined angle to avoid back-reflections. A collimating assembly is attached to the output of the fiber and is adjusted such that the final beam is well collimated at approximately 8 mm. Again, note that this collimation adjustment is performed at the factory, is extremely sensitive, critical for the gravity measurement, and should not need to be adjusted.

Finally, because the laser light is polarized, it is necessary to rotate the output of the fiber about its axis so as to evenly split the laser power between the test and reference beams (horizontally polarized light is transmitted more efficiently into the reference



beam, while more vertically polarized light is transmitted in the test beam – the nominal position is thus at about  $45^\circ$ ). Again, this adjustment is performed at the factory and should not need to be changed by the user.



## 3 FG5 SETUP

NOTE: These instructions are based on the assumption that all subsystems of the FG5 are aligned correctly and operating properly. If adjustment or alignment is necessary, consult Section 4, “Adjustment and Maintenance” for instructions, before proceeding with set up. When setting up the FG5, it is helpful to use the FG5 Setup Checklist in Section 10.

### 3.1 Instrument Assembly

Locate and mark a reference point on the floor where gravity will be measured. The floor should be as clean, smooth, and level as possible. It is best to set up the FG5 on a concrete pier or hard tile floor at ground level.

Note that these instructions assume that the dropping chamber is already at a high vacuum level. See Section 5 for instructions on pumping out the dropping chamber.

#### 3.1.1 Electronics Case

For a full discussion of the FG5 electronics, please refer to either the Tele-g or SIM instruction manual.

- Place the electronics case in a convenient location about 1 meter from the reference mark. Check the input voltage settings and make sure they are set to the proper AC line voltage. All components in the FG5 system, with the exception of the WEO laser, automatically switch to accommodate any line voltage from 100 – 240 VAC, 50 – 60 Hz. Please refer to the WEO laser manual for instructions on setting the proper line voltage.
- If the ion pump has been maintaining the dropper vacuum on battery power, apply AC power to the ion pump power supply. See Section 5 for more details on the ion pump controller.
- Make sure the following switches are off:
  - Power Supply: Main AC power (rear)
  - Power Supply: Main DC power (rear)
  - Laser power (both main AC power and high-voltage key switch)
- Open the Interferometer case, and place the laser on the floor about 1 m from the reference mark. Take care not to stress the fiber optic cable.
- Connect the main AC power cable from the FG5 power supply (rear of electronics case) to the AC power receptacle. If an uninterruptible power supply is to be used with the FG5, it should be connected to the main AC



power source and the FG5 AC power supply should be connected to the UPS output.

- Turn on the main AC power switch on the FG5 Power Supply (rear of electronics case).
- Connect the applicable cables to the laser and turn on the laser power: first AC power, then the HV. Consult the manual appropriate to the laser you are using. Is it important to turn on the laser as early as possible in the Setup procedures to let the laser reach thermal equilibrium before the measurements begin.

### **3.1.2 Setting up the Superspring Tripod**

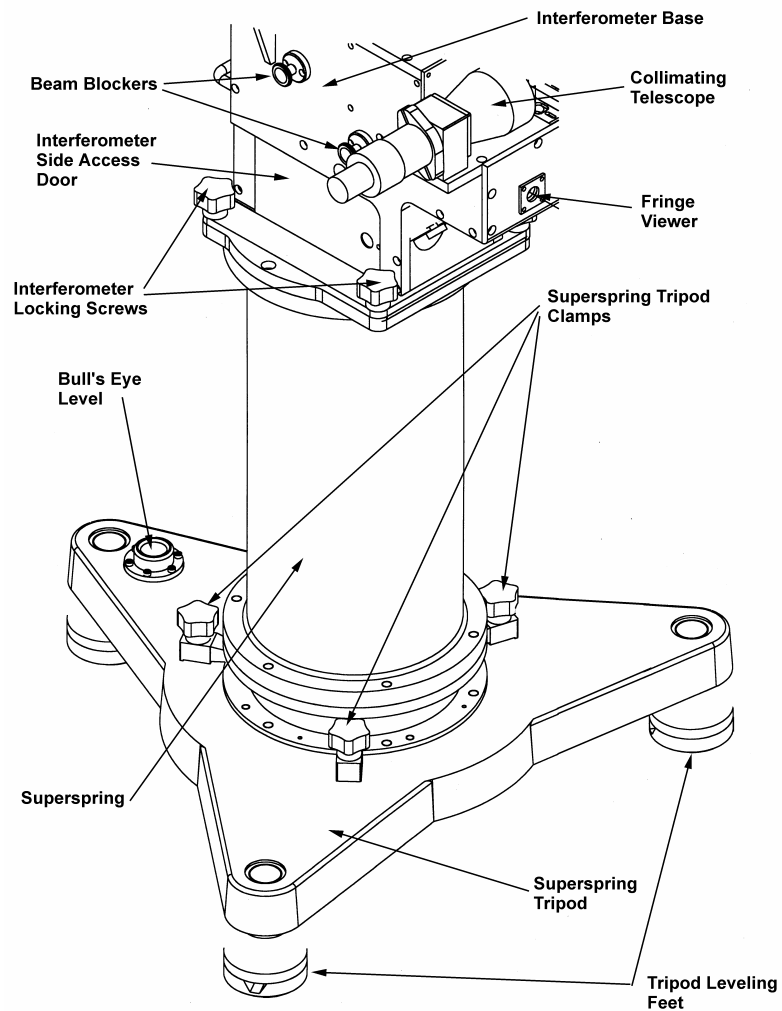

**Figure 11. Superspring/Interferometer Setup.** Note that the bubble level on the Superspring tripod is on the operator's left when the FG5 is set up. Also, the line from the center of the tripod to the bull's eye level should be oriented along the North-South axis.

Figure 11 illustrates the location of the Superspring and interferometer base for setup.

- Remove the Superspring tripod from the interferometer case and place on the floor over the reference mark. Orient the tripod so the bull's eye level (mounted near one of the leveling feet) is facing the electronics case, if possible. A line from the bull's eye level to the center of the tripod should be aligned either north or south to minimize Coriolis accelerations on the dropped object. The tripod can



be centered over the mark by viewing the mark through the hole in the center of the tripod.

- Rough-level the Superspring tripod using the bull's eye level. If using an FG5 with the Remote Operation option, please consult the Tele-g User's Manual for information on leveling the Superspring tripod.
- Measure the lower reference height using the depth gauge provided. The lower reference height is the distance between the Superspring tray ring and the reference mark (approximately 5-15 cm). Place the depth gauge parallel surface on the machined inside ring of the Superspring tripod. Pass the gauge rod through the hole in the center of the Superspring tripod and extend it until it hits the reference mark on the floor. Tighten the locking screw and measure gauge length using the ruler. Record this value in the system check log. This is referred to as the "lower set up height".
- Place the Superspring in the tripod. Orient the Superspring so that the travel lock (brass knurled knob on the service ring) is pointing toward the bull's eye level.
- Clamp the Superspring to the tripod by turning the three 5-lobe knobs fully clockwise. This rotates the clamps in place over the base of the Superspring.
- Level the tripod noting the two precision level vials on the base of the Superspring. Be sure to adjust the cross level first, then the long level. The cross level is opposite the Superspring travel lock (knurled brass knob). If the long level is adjusted first, it will change when the cross level is adjusted. When the cross level is adjusted first, it does not change when the long level is adjusted. Only turn two of the feet while leveling; this insures that the lower reference height does not change. Again, if using an FG5 with the Remote Operation option, please consult the Tele-g User's Manual for information on leveling the Superspring tripod.

Note: While leveling the Superspring and dropping chamber tripods, note that turning the tripod feet clockwise *lowers* the dropping chamber tripod and *raises* the Superspring tripod.

### 3.1.3 Interferometer

- Remove the interferometer base from its shipping case taking care not to stress the fiber optic cable. Remove the dust cap from the top Superspring window and place the interferometer base on the Superspring. Orient the interferometer base so the fiber optic input is located directly above the Superspring travel lock. The alignment pins on the top of the Superspring assure that the interferometer base is oriented correctly.
- Lock the interferometer base in place by tightening the four 5-lobe knobs.





### 3.1.4 Dropping Chamber Tripod

- Remove the tripod tray from the Superspring case and place it carefully upside-down in the lid of the transit case.
- Remove the three tripod legs from the dropping chamber case and attach them to the tray. If necessary, tighten the legs by using the ~30 cm “cheater” bar.
- At this point the interferometer will be used to support the dropping chamber tripod. First, remove the dust cap from the top of the interferometer base.
- Carefully place the dropping chamber tripod on the interferometer. Orient the tripod so that the small hole is above the Superspring travel lock and laser fiber. Be careful not to damage the mirror on the right side (near the telescope) of the interferometer base.
- Carefully remove the dropping chamber from its case by the handles and gently place it into the pocket in the top of the tripod tray, allowing the two vertical alignment pins in the tray to engage the sockets in the dropping chamber base. Orient the dropping chamber so the ion pump is directly above the beam blocker controls on the interferometer.
- Lock the dropping chamber in place with the three clamps by turning the 5-lobe knob fully clockwise. This rotates the dropping chamber clamps in place over the base of the chamber.

### 3.1.5 Leveling the Dropping Chamber

Note: While leveling the Superspring and dropping chamber tripods, note that turning the tripod feet clockwise *lowers* the dropping chamber tripod and *raises* the Superspring tripod

- Check the Superspring levels and adjust, if necessary, by leveling the Superspring tripod
- When the Superspring levels are centered, the dropping chamber tripod levels should be within two divisions or so of the center position. If the levels do not agree, this may indicate a problem. Consult Section 4 on adjustment and maintenance for instructions.
- Remove the blue pads and brass tripod feet from the Superspring case. Make sure the pads and tripod feet are clean.
- Place a tripod foot under each leg of the tripod. Raise each foot and slide a blue pad under the foot.
- Center the cone in each foot under the nylon ball on the end of each tripod leg. Turn the leveling adjustment screws on the feet counterclockwise, raising them until they just barely contact the balls. It is important that the foot and the nylon foot of the tripod leg are perfectly centered with each other. Otherwise, the dropping chamber will shift sideways when it is lifted. It is helpful to rotate, or wiggle, the foot slightly (while it is in contact with the nylon ball) to release any horizontal tension.
- After each foot is in contact with the tripod leg, rotate each tripod foot leveling screw one revolution (counterclockwise), using the mark on the top of the



- adjustment screw as a reference. Then, rotate each tripod foot leveling foot one additional revolution as described previously. It is important to do one turn at a time – this keeps the dropping chamber centered over the interferometer. The two total turns raise the tripod off of the interferometer so there is no contact between the two components. Each counterclockwise revolution of the leveling screw raises the tripod about 0.75 mm
- Fine tune the level of the tripod tray by adjusting the dropping chamber tripod feet (not the Superspring tripod legs). Again, be sure to adjust the cross level first, then the long level. The cross level is parallel to the telescope and the long level is perpendicular to the telescope.
  - It is best to adjust the levels by **raising** the appropriate adjustment foot. (If the foot is used to lower that side of the tripod, there is a risk that the tripod will contact the interferometer).

**Note** that there must be no contact between the tripod-dropping chamber assembly (and their cables) and the interferometer/Superspring assembly (and their cables) during the measurement.

- Check the Superspring levels and adjust, if necessary, using the leveling feet on the Superspring tripod. At this point all Superspring and Dropping Chamber bubbles should be centered.
- Measure the “upper set up height” using the ruler and fixture provided. The upper reference height is the distance between the top of the interferometer base and the bottom of the dropping chamber. Loosen the clamp on the ruler and pass the ruler up through the access hole in the dropping chamber tripod while pulling it slightly towards yourself (the hole is located directly above fiber optic input on the interferometer base) until it contacts the top of the interferometer base. The upper set up height should be approximately 6 cm. Record this value in the system check log. The sum of the upper and lower set up heights (approximately 13 cm) will be entered as the “Setup Height” term in “g” Process | Setup| Information. See the g Software Manual for details.
- Release the dropping chamber travel lock by turning the motor shaft slightly counterclockwise with a 4 mm hex wrench to release the pressure on the travel lock mechanism. While holding this position, pull up on the brass knob, rotate it 90° in either direction, and gently release it so the pin is not engaged on the motor shaft.

### 3.1.6 Cable Connections

**Note** for details on the electronics setup, please refer to the SIM or Tele-g User's Manual.

- Connect the computer power cable to the power supply panel or AC outlet.



- Connect the PCMCIA cable from the Magma PCI unit to the PCMCIA slot on the computer.
- Check that the grey ribbon cable from the rear of the SIM is connected to the Magma PCI unit.
- Connect the BNC cable from the interferometer base “TTL” connector to the “CHAN A” connector on the computer time interval card in the Magma PCI unit.
- Connect the BNC cable from the “10 MHz” connector on the power supply to the “CLK” connector on the computer time interval card in the Magma PCI unit.
- Connect the BNC cable from the TRIG OUT connector on the SIM to the “EXT ARM” connector on the computer time interval card in the Magma PCI unit.
- Connect the BNC cable from the interferometer base “ANALOG” connector to “ANALOG FRINGE IN” on the rear of the SIM.
- For the WEO Model 100 laser:
  - Connect the BNC cable from the OUTPUT connector on the front panel of the laser controller to “g Laser” on the front of the SIM . Make sure the meter select switch on the laser controller is set to the “1f” position.
- For the Model ML-1 Laser:
  - Connect the Laser LOCK and Laser MODE BNC cables from the ML-1 controller to the respective locations on the front of the SIM.
- Connect the BNC cable from the METER MONITOR connector on the ion pump power supply to “g ION” on the SIM. Set the meter select switch to the  $10^{-4}$  A scale.
- Make sure DC power on the FG5 Power Supply is OFF, and attach the rest of the system cables as described below. Both ends of all cables are labeled with the proper location for each connector.
  - Connect the rotary shaft encoder cable (blue Lemo connector) from the power supply panel to the blue Lemo connector on the motor drive assembly.
  - Connect the DC motor power cable (orange Lemo connector) from the power supply panel to the orange Lemo connector on the motor drive assembly.
  - Connect the APD power cable (green Lemo connector) from the power supply panel to the interferometer base “power” connector.

### 3.1.7 The Superspring

- Connect the Superspring control cable (yellow Lemo connector) from the power supply panel to the connector at the base of the Superspring. (The DC Power



should still be off at this point, but double-check: do not attach the Superspring control cable while Servo is on!

- Release the Superspring travel lock by pulling out the brass travel lock knob until it engages the shaft and slowly rotating it counterclockwise until it reaches the stop (approximately 180°). Slowly release the lock knob. The arrow on the lock knob points down when the spring is locked, and up when it is unlocked. Use a voltmeter to monitor the spring position (SS POS), and wait for the spring to settle down so that the “scatter” is about 50mV or less.

### 3.1.8 DC Power On

- Turn on DC Power. Near the DC Power switch, note that the Rubidium clock light will flash briefly and then stay dark until the clock locks at 10 MHz (typically within 5 or so minutes). On the SIM, verify that the dropper is in reset mode, and the spring has both ZERO and SERVO off. Depending on conditions, it is possible that one or more of these switches will be ON when the power is enabled. Make sure to turn them off as quickly as possible. For more information on the SIM, please refer to the SIM User's Manual.
- Next determine the spring position. After un-travel locking, the spring will take a few minutes to settle. After it has, determine its approximate mean position. If it is farther than about 20 mV from zero, enable the ZERO switch on the SIM. This brings the spring to the center of its range within a few minutes. When the position is within about 20 mV of zero (or stops moving) disable SS ZERO. It is normal for the SS POS value to fluctuate as the reference mass bounces on its spring, but eventually it should damp out, and the fluctuations should be  $\leq 20$  mV. At this point, enable SERVO.
- After five minutes or so, the “scatter” of the spring position should be 1-2 mV on a voltmeter. If the spring is not totally at thermal equilibrium, the position will slowly drift in one direction. This is normal and should not affect the measured gravity value (the spring is moving at approximately a constant velocity and will not affect the gravity determination).

### 3.1.9 Beam Verticality

- Before optimizing the alignment of the interferometer, make sure the test beam is perfectly vertical. Place the alcohol pool in the interferometer taking care to roughly center the laser beam in the pool. In the telescope you should see a solid light (the reference beam) and a vibrating light (test beam) that is reflecting from the alcohol pool. Adjust the angle of fiber optic using the mirror mount (left side of IB) until the test beam is exactly centered over the reference beam in the telescope. Use the beam blockers as necessary to help determine the positions of both the reference and test beams. Then remove the alcohol pool.
- Note that for convenience, it is possible to move the test and reference beams to the center of the telescope viewfinder by adjusting mirror # 3, located in front of



the telescope objective. Note this does not affect the interferometer alignment; it is only for the user's convenience.

### 3.1.10 Fringe Optimization

- To optimize the fringe signal, the test and reference beams must be made perfectly coincident and parallel. The two interfering beams should be perfectly overlapped and also have no angular deviation for the greatest signal. Note though that at this point (the beam is vertical) no further adjustments can or should be made to the reference beam. The test beam is adjusted to match the position of the reference beam. The translation of the test beam is done by adjusting the translator plate (usually called the “twiddler”). The angular deviation is adjusted by adjusting mirror mount # 2, located below the telescope (see Figure 8).
- Note that for convenience, it is possible to move the test and reference beams to the center of the telescope viewfinder by adjusting mirror # 3, located in front of the telescope objective. Note this does not affect the interferometer alignment; it is only for the user's convenience.
- Look in the viewport (on the right side of the IB – not the telescope) and adjust the twiddler until the test beam overlaps the reference beam.
- Look in the telescope and adjust mirror # 2 so that the test beam overlaps the reference beam. Use the two knobs that are diagonally opposite of each other. The two beams are now at least roughly coincident and parallel.
- Connect the ANALOG FRINGE output on the SIM to an oscilloscope, with the following settings:
  - Vertical scale = 50 mV/div
  - Horizontal scale = 2  $\mu$ sec/div
  - AC coupled input
  - Automatic trigger at 0V
- Make sure the laser is locked. Set the dropper to OSC mode by pressing OSC on the SIM. This moves the cart slowly up and down at a constant velocity and produces a constant frequency fringe signal which is useful for adjusting the Twiddler and Mirror #2.
- Maximize the fringe signal on the oscilloscope by adjusting Mirror # 2. Use the two adjustment knobs that are located diagonally from each other. Optimize the mirror in both directions (horizontal and vertical).
- Further maximize the fringe signal on the oscilloscope by adjusting the twiddler.



- Return to Mirror #2 and fine tune in both directions to perfectly maximize the fringe amplitude. Nominal fringe signal is 300 - 400 mV, peak-to-peak. Record this value in the system check log.
- [In general, do not operate the FG5 if the fringes are below 300 mV or above 400 mV. This can adversely affect the measured gravity value. See Section 4 for troubleshooting details.]
- Terminate OSC mode by pressing DROP on the SIM (this places the dropper controller in DROP mode, ready for data acquisition). This brings the cart safely down the bottom at the end of next OSC cycle. Note that you can press the DROP button at any point in the cart's motion. Alternatively, pressing TRIG will place the dropper in REST mode at the end of the next OSC cycle. Pressing RESET will cease all power to the motor causing it to drop from wherever it is.

If the fringe amplitude is too small (less than 250 mV, or has dropped noticeably from earlier measurements), it is most likely an alignment problem. Make sure that there is enough range in the Twiddler to overlap the beams well. Make sure that the beams are both circular, and not "clipped".

Laser power is also directly related to fringe amplitude, and it is possible that the laser may have lost power to a bump that has changed either the internal or fiber optic cable alignment. While a complete discussion of laser power is beyond the scope of this manual (see WEO-100 User's Manual), double check the DC voltage (laser power) on the WEO controller to make sure it is what you expect (typically 5-10 V is adequate).

- Finally, as a double-check against any bumps or misalignments, it best to check verticality one last time and then do not touch the instrument until the end of the measurement cycle.



## 3.2 Software Set Up

**Note:** See the g User's Manual for a complete discussion of the software and setup procedures. Listed below are some FG5 specific set up notes.

Power on the computer system as follows:

- Power on the AC to the Magma PCI unit. Turn on the power switch on the front of the Magma
- Verify that the PCMCIA cable is attached from the Magma PCI unit to the PCMCIA slot on the laptop computer
- Power on the laptop computer
- **Note:** do not let the laptop “sleep” or “hibernate” – this will cause problems with the laptop/Magma connection, and it will then be necessary to reboot everything in the above order.

### 3.2.1 Information Setup

Reference Height - enter the total reference height (the sum of the lower and upper reference heights measured in Section 3.1).

### 3.2.2 System Setup

- FG5s that ship with “L Series” (Micro-g ML-1 lasers). The laser frequencies are calibrated at Micro-g (see Section 2.6 for details on the ML-1 laser). It should not be necessary to change these values! Set the Pre-run lock time to be approximately 30-60 s. This is the time the laser is allowed to lock prior to the beginning of each set. In the *Acquisition* section it is necessary to make sure that there is enough time to take all the data and allow for laser lock between sets.
- FG5s that ship with WEO (100 or 200) lasers. These wavelengths are determined at BIPM, and should never be changed. Refer to the WEO manual for the exact value of the laser modulation frequency. Use a voltmeter to measure the 1f voltages for peaks d – g, and enter these values here. (Note that if a peak d – g is chosen for data acquisition, it is NOT necessary to enter values for h – j).

The correct Guide Card Parameters must be set in the same manner using the “Setup” button beneath the Fringe Card box. The recommended settings for a standard FG5 dropper are:

Input Multiplexor:	4
Prescale:	250
Fringes Acquired:	700





A2D card settings must also be entered. For the National Instruments card, the recommended settings are as follows:

**Table 1. DAQ Card Settings**

	Offset	Multiplier
Channel 0	0	100
Channel 1	0	1
Channel 2	0	1
Channel 3	0	1
Channel 4	537.5	125

Single – Ended

The final change on the system page is to ensure that the “Serial Baro” box is unchecked.

### 3.2.3 Acquisition Setup

Next, select the appropriate start time option, and then enter the drop interval (a minimum of 5 seconds should be used with an FG5). The set interval should be set to your choosing. Finally, look at Pulse Delay - the time between the lift and drop of the test mass. This should be about 1/3 of the drop interval, or set to a minimum of 3 seconds. If the intervals are inconsistent the software will warn you. Typical intervals for an FG5 are 10 seconds per drop.

There is a whole possible philosophical discussion of “how much data is enough?” The short answer is to take enough data so that statistically you have the precision you desire. This might require a short test run to determine the drop-to-drop scatter in the measurements.

### 3.2.4 Control Setup

The first section in *Control Setup* is “General Terms” showing the gravity corrections that can be applied. For the initial setup, select all of these terms.

“Tidal Terms” is next. Select “ETGTAB” for the first test run. For each new location, it is necessary to enter Setup and Run Ocean Load. Make sure that the ocean load files created have unique filenames, and that you are using the correct ocean load files for your current location.





For the laser section, select the Auto Peak Detect (the software will then automatically select the mode and lock the laser prior to each set).

For the "Data" section of this page enter the start and stop fringe times: typically 35 ms to 200 ms.

Again, a complete discussion of all of these options is discussed in the g User's Manual.



### 3.3 Running the Gravimeter

#### 3.3.1 Starting the Measurement

Before starting the meter, make sure of the following:

- Superspring and Dropper have been unlocked, the Superspring servo is on, and the units have been separated
- The dropper controller is set to the drop mode
- For ML-1 lasers: The laser is in REMOTE mode, with the left LED illuminated, (and should therefore be UNLOCKED at this point. Whether the mode is RED or BLUE at this point is irrelevant.) The software will automatically select the mode and lock the laser prior to measurement.
- For WEO lasers: The laser is locked on a peak ( $d - g$ ) and the Monitor output is connected to "g LASER" on the SIM
- the Rubidium LOCK is on

In *g*, Select *Process / Go*, or hit the GO button on the toolbar (or use F5 as a quick key).

Assuming the meter is functioning correctly, the "State" display will show the value of gravity (among many other things), a graph of each drop relative to the current mean value, and the residuals of the parabola fit. See the *g* User's Manual for a complete discussion of all the *g* windows.

When the first set is completed, it is automatically saved to disk. Note that at this point, if the application is stopped, the Project is no longer in real time mode. That is, if you enter *Stop* and then *Process / Go*, the program will replay the data, rather than operate the FG5.

When all the sets have finished, it is safe to quit the application (the data are already automatically saved at the end of each set). If you notice a problem, and stop the acquisition during the first set, you can restart the project without creating a new project. If you stop during any other set (after Set 1) however, *g* will automatically save all the completed sets and you will lose whatever data was in the incomplete set. **Note that it is important not to stop *g* until the data from the previous set(s) has been written to disk** (this can be seen on the bottom right of the screen). Stopping the program during this time can cause *g* to crash and data to be lost! This process can take several seconds.



### 3.3.2 Data Quality

While a complete discussion of data analysis and interpretation is beyond the scope of this manual, a basic understanding will help ensure that your data is of high quality.

- Drop Residuals: The residuals are the difference between the actual, measured fringe location and the final, best-fit parabola. Make sure that the residuals are relatively flat ( $<1$  nm).
- The State Window
  - Note the Drop Gravity Value. Verify it is reasonable.
  - Note the values of the analog signals: For example, are the barometric pressure and spring position, reasonable and stable?
  - Note the value, in  $\mu\text{Gals}$ , of the gravity corrections. Are they reasonable?
- Drop Gravity: Is the drop-to-drop scatter reasonable, given your location? In a quiet, stable, laboratory, this should be approximately 5 - 30  $\mu\text{Gal}$ . In the field, of course, this might be higher. Is the mean stable? There should be no noticeable drift in the mean value throughout the set.
- Laser (ML-1): Between sets, verify that the system is unlocking the laser, and then relocking to the alternate laser peak before the next set starts. From set-to-set, are the RED and BLUE gravity values self consistent? If for some reason the RED and BLUE locks have become switched in the software, a 1.4 milli-Gal difference will be observed. This can be easily fixed by stopping data collection and clicking the 'Switch' button found in the 'Setup' tab of the 'System' parameters. (This can be done in replay as well.)
- Laser (WEO): is the software automatically detecting the right peak? The difference, in  $\mu\text{Gals}$ , between laser peak wavelengths is about 25  $\mu\text{Gals}$ .

### 3.3.3 Reprocessing Data

Once the measurement is finished (or if it is stopped after the completion of at least the first set), clicking *Process / Go* will cause the system to "replay" the data. The program will ask you if you would like to overwrite the previous output file (project.txt). Clicking YES (or choosing a different output filename), will cause the program to read the data files from the disk, and re-process each drop. If desired, it is possible to change the input parameters (common examples include a new nominal pressure, more detailed location values, etc.) and then replay the data. The parameter settings in place at the actual time of measurement can always be recovered by clicking *Edit / Reset / All*.



### 3.4 Shutting Down the FG5

If the FG5 is not to be used for a long period, shut everything down with the exception of the ion pump power supply. Even if the instrument is to be stored for a few months, it is better to leave it under vacuum with the ion pump on. Only if shipping regulations require it, should the ion pump be turned off.

- If desired, back up any data and then close all the windows on the computer, and power the computer down.
- Turn DC POWER off.
- Turn off the laser high voltage and then turn off laser power.
- Back up data if applicable and shut down the laptop computer
- Turn AC POWER off
- Dropping Chamber (and Superspring):
  - Travel-lock the dropping chamber:
    - Lock the cart by turning the locking hub (motor shaft) counterclockwise using a 4 mm Allen wrench or ball driver until the cart stops moving
    - Pull and rotate travel lock knob 90°, allowing the pin to drop onto the hub, then rotate the locking hub clockwise until the pin engages the hub.
  - Travel lock the Superspring:
    - Pull out the travel lock brass knob until it engages the locking mechanism, and rotate the lock 180° clockwise to lock it in place. The arrow on the lock knob points down when it is locked and up when it is unlocked
  - Open the three dropping chamber clamps by turning the 5-lobe knobs fully counterclockwise so the clamps are outside the bottom flange of the dropping chamber.
- Gently lift the chamber off the tripod and set it in its case. If the HV and safety ground cables are still connected, take care not to stress them.
- Disconnect the following cables:
  - APD power cable (green)
  - Superspring control cable (yellow)
  - Dropper motor (orange) and encoder (blue)
  - Interferometer TTL BNC cable
  - Interferometer Analog BNC cable
  - Ion pump monitor BNC cable
  - Any cable connected to the system computer.
- Dropping Chamber Tripod
  - Carefully remove the tripod from the interferometer base. Remove the legs from the tripod. Place the legs in the dropping chamber case along with the tripod tray and feet.
  - Close dropping chamber case and secure all latches.
- Interferometer



- Insert the dust plug into the top of the interferometer base.
- Loosen the four 5-lobe knobs which attach the interferometer base to the Superspring.
- Remove the interferometer base from the Superspring and gently place it in the shipping case along with the laser. Take care not to stress the fiber optic.
- Close the interferometer case and secure all latches.
- Superspring (cont.)
  - (The Superspring should already be travel-locked)
  - Insert the dust plug in the top of the Superspring.
  - Loosen the three 5-lobe knobs which attach the Superspring to the Superspring tripod.
  - Remove the Superspring from the tripod and place in its shipping case.
  - Close the Superspring shipping case and secure all latches.



## 4 Adjustment and Maintenance

With proper and careful setup and operation, the FG5 should provide accurate and reliable results. However, if you suspect that there is a problem, before attempting repairs or adjustments yourself, it is usually a good idea to first contact Micro-g LaCoste at

[www.microglacoste.com/contact.htm](http://www.microglacoste.com/contact.htm)

So, while a full list of all adjustments is beyond the scope of this manual, listed below are some common issues, their explanation, and their resolutions...

### 4.1 Superspring

Superspring problems usually manifest themselves as either an inability to zero properly or through high drop scatter and strange residuals. In some cases it will be necessary to open the Superspring to ascertain the source of the problem.

#### 4.1.1 Removing the Superspring Cover

If it is necessary to open the Superspring, place it in its tripod, level it, make sure it is travel locked, and loosen the 6 screws at the **bottom** of the main can, and remove the whole can and lid straight up together. Note that there are punch marks to indicate the orientation of the can relative to the Superspring base.

**Note.** Do not open the cover by removing the bottom flange! This will damage the internal electrical connections through the service ring.

#### 4.1.2 The Spring Position is off the Detector

If, for some reason, the mass is extremely far from the center of its range (e.g. due to an extreme change in either temperature or local gravity), the spring controller may appear to be behaving incorrectly: it may appear to go the “wrong way” (e.g. more negative, even though the motor is set to lift the mass – See Figure 12). This is because all of the light from the LED is not actually on the detector. As more light misses the detector (either going off the top or bottom), the absolute value of the voltage becomes less and less, making it appear that the spring is nearer zero than it actually is. (**Note that this problem is handled automatically in the newer Superspring controllers.**)

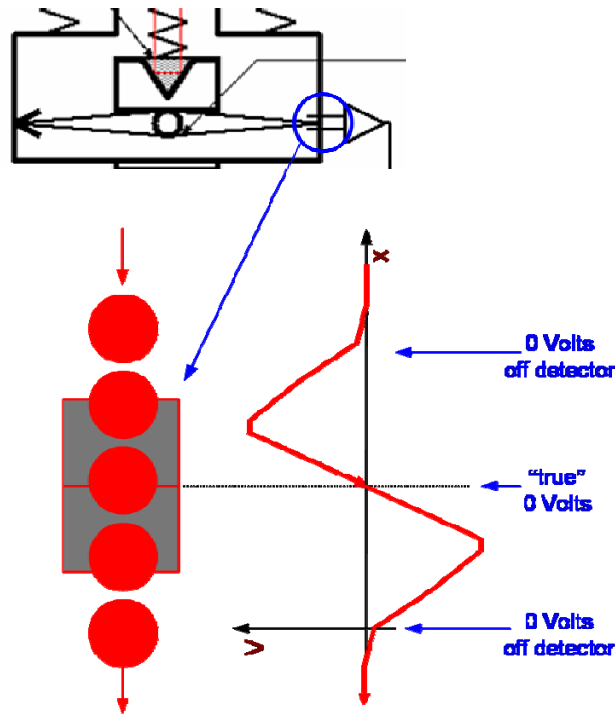

**Figure 12.** If the LED light is off of the detector, the SPHERE position will read about zero volts. As the light is brought on the detector, the voltage appears to go the “wrong” way at first. Keep moving the spring position until it is about the “true” zero value. Note that the spring position will only go positive and negative about the true zero value. This phenomenon is known as the Superspring “S Curve”.

For example, if the light is shining off the bottom of the detector, raising the motor will cause more light to shine on the detector. As the mass is raised further, more and more light comes back on to the lower (negative) side. The spring thus appears to be at a more negative position, even though it is rising. (The converse holds true if the spring is being lowered down from above the detector).

The Zero function of the SIM (see SIM Reference Manual) automatically accounts for this when zeroing the spring position. As a check to make sure everything is functioning normally, the spring should oscillate between positive and negative voltage when it is around the true zero (center) of its range.

### 4.1.3 Superspring will not go to Zero

In some cases, the automatic zero function will not bring the system to the center of its range. Normally this happens when the spring is so far out of range that the circuit “thinks” the spring really is at zero (or it is so close to zero that the motor moves extremely slowly). The “trick” is to enable ZERO on the SIM, and then travel lock and un-travel lock the Superspring (perhaps repeatedly). This will cause the mainspring to bounce, and the end will, at some point, cross the detector. This allows the circuit to “see” the true position, and adjust the position accordingly.



If that does not work, open the Superspring (as described above) and check to make sure that the limit switches have not be engaged.

#### **4.1.4 Gravity data shows very large Scatter or large Residuals**

If the gravity meter shows larger-than-normal scatter, or the residual size is larger than about 10 nm, this can indicate bent or broken Superspring flexures. This is typically caused by rough handling during transport. Remove the Superspring cover as described above, and check each flexure for straightness. Figure 13 shows a photograph of a bent Superspring Flexure.

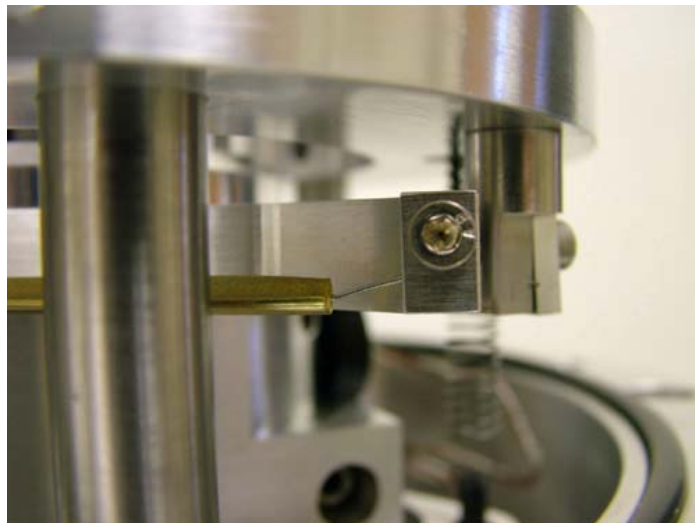

**Figure 13. Bent Superspring Flexure. The small wire and the brass portion of the flexure should be parallel.**

If the flexure(s) is bent, the repair is usually as simple as taking a standard pencil and using the eraser end to “push” the flexure back straight.

If the small wire portion of the flexure has completely broken off, it will be necessary to replace the flexure. Simply loosen the Allan screws and remove the broken flexure. Take a replacement flexure (standard pieces in an FG5 toolkit), and attach the end on the “outside” of the Superspring first. The “outside” is the portion that connects to the main rings and vertical posts that are attached to the Superspring base.

Next, attach the “inner” side of the flexure. Un-travel lock the Superspring and let it settle. Locate the 6 guide pins along the Mainspring tube, as shown in Figure 14, and use a feeler gauge (or eyeball, in worst case) to verify that that all 6 gaps are equal. If one or more is too small, loosen and reset the inner portion of the corresponding flexure. Iterate this procedure for all flexures until all 6 gaps at the guide pins are equal.





**Note** Never loosen the guide pins. These are set at the factory and are your only reference for aligning the flexures that allows the servo mechanism to have the necessary clearance to function.

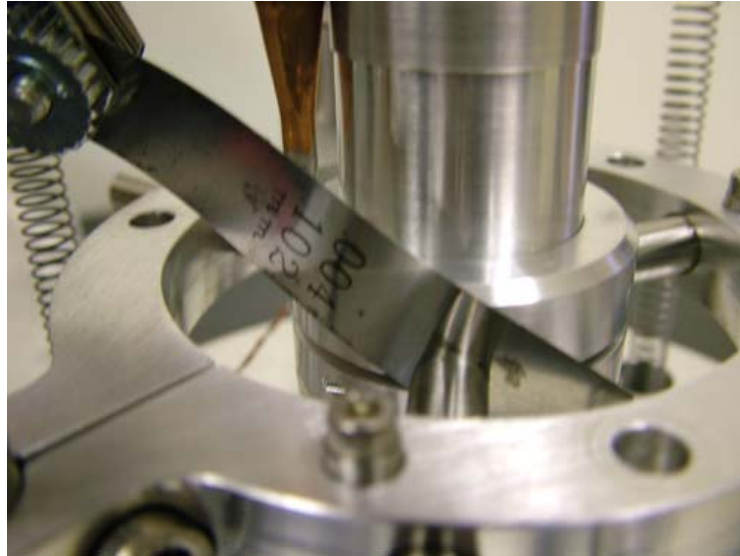

**Figure 14. Using a feeler gauge to monitor the gap spacing on the Superspring guide pins.**

#### **4.1.5 Alignment**

Completely aligning the Superspring is beyond the scope of this manual, but in the rare case that the Superspring bubble levels become misaligned, resetting them is simple: Just place the Superspring on a perfectly level table, and set the bubbles to the center using a 2.5 mm Allan wrench and an 8 mm open end wrench.

### **4.2 Dropping Chamber**

Dropping chamber issues can be broken into the following categories: ion pump, feedthrough, tuning, drive belt, and alignment.

#### **4.2.1 Ion pump Issues**

Once the vacuum is established and the ion pump is functioning, typically there is very little that can go wrong with an ion pump. However, if the vacuum is somehow lost, and the vacuum level is compromised while gravity data are being acquired, a characteristic “sine wave” will start to appear in the residual plot (see Figure 15). At this point, the data are un-recoverable, and the system will need to have the vacuum restored (see Section 5 for more details).

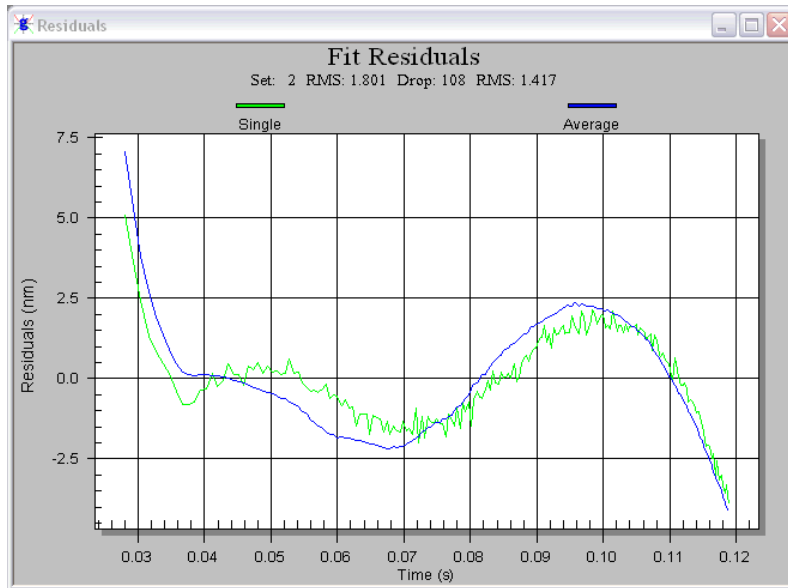

**Figure 15. Characteristic Residuals signal when the vacuum is poor. Note the vertical scale is about 10X larger than normal.**

#### 4.2.2 Feedthrough Issues

The ferro-fluidic feedthrough is what allows the external motor to drive the dropper cart through the vacuum wall. When the FG5 has been sitting idle for a while (10s of minutes), it is normal to see a momentary increase in ion pump current for the first few drops. This is due to the release of molecules in the feedthrough mechanism. The ion pump then “catches up”, and the vacuum returns to normal.

The feedthroughs typically have a lifetime of about 2 – 3 years. When they begin to fail, you will notice that the ion pump increases are larger, and take many, many drops to return to normal. When the feedthrough finally fails completely, the increase is “permanent” through all the drops, and the vacuum does not recover until the dropper is idle. At this point, it is necessary to replace the feedthrough. Though the replacement procedure is beyond the scope of this manual, it is something an advanced user can perform. Please contact Micro-g LaCoste for instructions on the replacement.

#### 4.2.3 Dropper Tuning Adjustments

Again, a full discussion of the dropper tuning circuit is too large for this manual, but there are a few common “tricks” that can be useful.

With time and/or temperature changes, it is possible that the servo circuit needs to be adjusted from the original factory settings. The common symptom is that OSC mode will “time out” and the dropper controller will go into RESET mode (DROP mode normally still works well). To correct this, open the lid of the SIM unit and locate the dropper controller circuit board on the left. In the middle of this board is a



potentiometer labeled “POS GAIN” (short for “position gain”). Simply use a small regular screwdriver and turn this clockwise approximately  $\frac{1}{4}$  turn.

#### 4.2.4 Drive Belt Replacement

If the drive belt breaks, please contact Micro-g LaCoste for instructions. Spare drive belts are standard equipment in the FG5 toolkit, and this is a repair that advanced users can make themselves.

#### 4.2.5 Dropper Alignment

The bubble levels are set at the factory to insure that the dropper is oriented correctly at each setup. They are used to ensure that the cart precisely catches the test mass at the bottom of the drop (even if they are not precisely vertical with respect to the outside of the chamber, or even if they are not exactly straight). However, if the bubbles somehow become loose, or if the chamber is opened for any reason, they will need to be reset.

**Note** Unlike the Superspring, the bubbles are not simply set to make the dropper level. Rather, the dropper needs to be tilted (generally, **not** level) to an optimal position, and then the bubbles are set so that this position can be repeated.

Make sure the chamber is well separated (5 or more turns of the feet) from the interferometer and that the laser beam traveling into the chamber is vertical (using the alcohol pool).

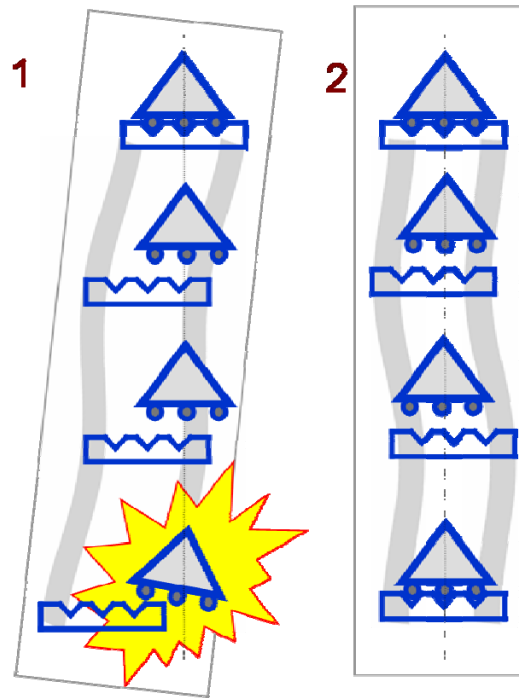

**Figure 16. Chamber alignment. Plot 1 shows poor alignment . Plot 2 shows the dropping chamber tilted such that the cart position at the bottom of the drop is directly below the top of the drop. Note that, in general, the tilt of the chamber is not necessarily vertical. Also, the tilt and rod-bend have been greatly exaggerated.**

Place the XY detector (part of the standard FG5 toolkit) in the path of the vertical beam and attach the power cable to the Auxiliary output connector on the FG5 Power Supply. Attach the X and Y outputs to Ch1 and Ch2 of an oscilloscope and place the oscilloscope in “XY” mode (500 mV/div on both channels and ~250 ms in time). Use the oscilloscope’s position knobs to center the two grounded channels in the middle of the oscilloscope. Finally, attach the  $\Sigma$  (or sum) channel to a digital voltmeter.

With the oscilloscope set to DC coupling on both channels, use the adjustment knobs on the XY detector to center the signal in the oscilloscope. Manually run the cart up and down using a 4 mm Allen wrench. Watch the value on the voltmeter, and make sure that it doesn’t change by more than 10% throughout the travel of the cart (thus indicating that laser light is staying on the detector the whole time). If the spot moves visibly as the cart is raised and lowered, use the tripod feet to tilt the chamber so that the spot appears stationary. Then repeat the above: center the signal and make sure the spot stays on the detector throughout the cart’s travel.

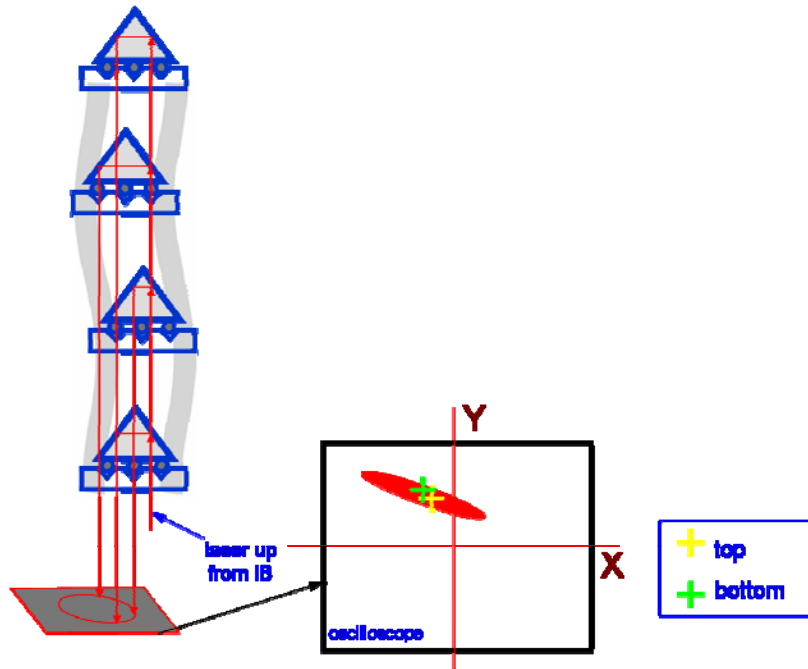

**Figure 17. Using the X-Y detector to set dropping chamber bubble levels. In general, as the cart is lifted up and down, it will also move slightly sideways. Thus, the reflected laser beam will appear to translate. Tilt the chamber until the position of the reflected beam at the top of the drop is the same as at the bottom of the drop. Then set the bubble levels to read zero. Again the rod bend and translation are exaggerated.**

Manually lift the cart to the top of its travel. Note the position of the signal on the oscilloscope (it might be necessary to adjust the X and Y ranges, though it is best if both channels have the same V/div). Now watch the motion of the signal as the cart is slowly lowered. As an example, say the signal moved “down to the left by two divisions”. With the cart at the bottom, use the appropriate (trial and error) combination of dropping chamber tripod feet to “move” the signal in the same direction, and the same amount, as the signal moved as the cart was lowered (in our example, “down to the left by two divisions”). Here “tripod feet” refers to the large feet on the ground used to decouple the dropping chamber tripod from the interferometer.

Repeat the procedure: raise the cart, note the position, watch the motion as it is lowered, and adjust the appropriate tripod feet. As the chamber angle is improved, it will become necessary to go to finer and finer voltage scales to see changes in the motion. When the top and bottom position agree on the oscilloscope to ~10 mV, the chamber is aligned.



Note that if the rods are slightly bent, the signal might do a little “loop” or “wiggle” as the cart is raised and lowered. This is normal. It is only important that the top and the bottom of the travel are overlapped.

Once the chamber is aligned, center and lock the bubble levels.

Then, re-couple the dropping chamber tripod to the interferometer. Use the spanner wrenches provided in the FG5 toolkit to tilt the dropper tripod so that the dropping chamber bubble levels are centered to agree with those of the Superspring. See Figure 18. Location of the Dropper Tripod Adjustable Feet. By adjusting the height of these 3 feet, the tilt of the dropping chamber can be made to match that of the Superspring. for the location of the feet used to tilt the dropping chamber tripod relative to the interferometer base.

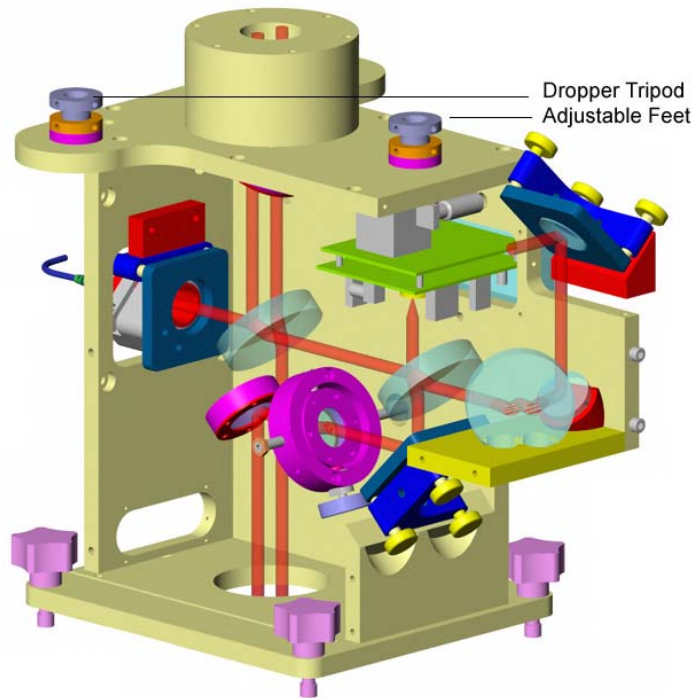

**Figure 18. Location of the Dropper Tripod Adjustable Feet. By adjusting the height of these 3 feet, the tilt of the dropping chamber can be made to match that of the Superspring.**

### **4.3 The Laser**

Laser issues can usually be grouped into two categories: stability issues and alignment issues. Stability in the laser wavelength is crucial: this provides the



length standard with which the gravity value is calculated. It must be stable to at least a few parts in  $10^9$ . Alignment problems in the laser usually result in a loss of power which will ultimately cause a decrease in the interference fringe amplitude. If the amplitude is too small, the data acquisition system will fail.

With a bit of careful analysis, it can actually be quite easy to at least diagnose most laser problems.

### 4.3.1 Laser Stability

- **ML-1 lasers.** For a complete description of the ML-1 operation, please consult the ML-1 User's Manual. Temperature changes are the biggest cause of laser wavelength instability in the ML-1. The laser housing is designed to be temperature stabilized, but even minute changes in environment temperature (fractions of a °C) can cause the laser wavelength to change, which in turn causes a noticeable change in the measured gravity value (even 10s of  $\mu\text{Gals}$ ). As the temperature changes, the RED or BLUE gravity values will change. However, the mean value is usually quite stable to a few  $\mu\text{Gals}$  (i.e. if the RED "drifts" up, the BLUE will "drift" down a roughly equal and opposite amount). Always let the laser come to thermal equilibrium before acquiring gravity data: typically 1-4 hours is necessary.
- **WEO lasers.** Again, please consult the WEO User's Manual for a complete discussion of the laser operation. Unlike the ML-1, if the controller indicates the laser is locked, the wavelength of the laser output will be correct and stable. However, if the laser has not yet reached thermal equilibrium, it will frequently lose lock status and then take a few seconds to re-lock.

As described earlier, the wavelength is labeled by a peak name (e.g. "d, e, f, or g"). Each peak has a unique 1f voltage, and this is what is entered into the software so that the correct wavelength can be used in the gravity value calculation. When the laser is not in thermal equilibrium (i.e. when it is first powered on), these 1f voltages will change. Therefore it is important to wait until equilibrium (again a minimum of about 1-4 hours) before measuring the 1f voltage.

If the software is using the wrong wavelength for the gravity calculation, obviously the reported gravity value will be incorrect. If it is using the adjacent peak value ("off by one peak", e.g. "d" instead of "e"), the gravity value will be wrong by approximately  $25 \mu\text{Gal}$ . Therefore, if looking at gravity data that appears to have  $20 - 30 \mu\text{Gal}$  jumps between sets, double check that the 1f voltages and autopeak detection setup in the "g" software are configured correctly. Finally, note that if the laser "hops" between peaks during a set acquisition, the average value of the set can be off by any fraction of  $20 - 30 \mu\text{Gal}$  (i.e. if the laser hops halfway through a set, the gravity value would be off by about  $12 \mu\text{Gal}$ ).



### 4.3.2 Laser Alignment

For both the ML-1 and WEO lasers, aligning the fiber to the laser head correctly is extremely important: not only does a proper alignment insure the maximum interference fringe amplitude, it also governs the power stability of the laser light. Both the fiber optic cable and the laser light itself are polarized, and it is crucial that the fiber be aligned with the direction of the laser beam and also rotated about its axis so that its polarization matches that of the laser beam.

Between the laser head and the entrance to the fiber optic coupler (or “fiber”), the laser passes through an optical isolator. This component allows the laser light to travel through it, but does not allow (reflected) light to return back to the laser cell. This is important because any errant light entering the laser cell (referred to as “feedback”) can interfere with the stability of the frequency lock.

The isolator is optimized at the factory to provide maximum feedback rejection and the user should not have to adjust it. However, if it is noticed that a piece of the isolator is loose, contact Micro-g immediately to receive information on reassembling the isolator (or receiving a replacement). If a piece is loose, it is extremely likely that isolator is no longer functioning and that the laser will not lock reliably.

The only adjustment necessary regarding the isolator is this: the whole unit must be rotated so that its polarization matches that of the laser. Simply place a power meter at the output of the isolator and rotate the isolator until the power is maximized. Clamp the isolator in place.

### 4.3.3 5-Axis Mount

The fiber is coupled to the laser head via a “5-axis” mount. The name refers to the fact that the mount allows lateral translation of the fiber relative to the beam in both the X and Y directions (2 axes), the mount allows tilt of the fiber in both pitch and yaw (2 axes), and the mount allows longitudinal translation of the fiber so as to focus the laser beam into the fiber (1 axis). Note the mount also allows rotation of the fiber relative to the beam (yet one more axis for an actual total of “6”)---the subject of the next section.

Getting laser light through a fiber is somewhat tricky and requires patience and practice. However, the principles are quite simple: one is trying to align the entrance of the fiber with a laser beam focused down to a few microns in diameter. Both the location of the fiber entrance and the fiber’s angle must coincide with that of the laser beam.





- Attach the 5-axis mount to the laser head and translate it such that the laser light is traveling through the center. (Verify by holding a piece of paper up and making sure the beam is not clipped)
- Attach the fiber to the 5-axis mount and tighten firmly.
- Use the X and Y screws on the side of the 5-axis mount to get some light through the fiber. While you should never look directly into the fiber, it should be possible to see the output end of the fiber “glow” with a small amount of light. If no light is visible, slowly translate the X and Y screws in a search pattern while looking for a “glow” at the output end of the fiber. When a small glow is visible, it is now best to attach the fiber to a laser power meter.
- Using the power meter, carefully adjust the X and Y screws until the power is maximized.
- Now use the three screws on the front to adjust the angle of the fiber. Iterate through all three screws – this not only changes the angle, but the focus (distance from the fiber entrance to the focusing lens) as well--- turning each one in the direction of maximum power.
- Now return to the X and Y screws and adjust them *slightly* to maximize the power. Then return to the three front screws and repeat the procedure.
- After many (10 or more) iterations the laser power should be maximized.

#### 4.3.4 Fiber polarization

When the power is maximized (or at least about 100  $\mu\text{W}$  for an ML-1 laser) it is then necessary to rotate the fiber so as to match its polarization to that of the laser. Note that, unfortunately, this most likely means a great (if not complete) loss of light in the fiber! Finally, note that this procedure requires not only a sensitive laser power meter, but a high quality, rotatable, polarizer as well.

- Shine the light from the output of the fiber through the polarizer and onto the laser power meter. Rotate the polarizer until the laser power is maximized and note the value. This is the “transmitted” power.
- Now rotate the polarizer until the power is minimized (this might require a rescaling of the power meter). Next, form a coil of excess fiber in your hand and let the heat slightly change the length of the fiber. This will most likely cause the power to increase. Note the maximum value attained. This is the “rejected” power.
- Calculate the ratio of “rejected” to “transmitted”. This ratio should be less than 1:100.
  - If the rejection ratio is  $\leq 1:100$  then great! Make sure the “large” black screws on the front of the 5-axis mount are tight, fine tune the laser power, and proceed to the *Last Step*.
  - If the rejection is  $\geq 1:100$ . Note the orientation of the fiber relative to the 5-axis mount. Slightly loosen (so as not to drastically change the angle of the fiber) the 3 “large” black screws on the front of the mount, slowly rotate the whole fiber. There are two optimal orientations of the fiber,



180° apart. If the rejection was close to 1:100, rotate a few degrees. If the rejection was basically 1:1, then rotate approximately 90°. If the rejection was in between, use the above information to estimate a reasonable amount of rotation.

- Once the orientation has been chosen, use the 5 adjustment screws to get at least 100  $\mu\text{W}$  of light through the fiber again. Repeat the rejection measurement and calculation.
- Repeat the whole procedure (rotate, regain the light, measure the rejection) until the rejection is at least 1:100. Once 1:100 is achieved, use the 3 “large” black screws to clamp the fiber rotation into place and proceed to the *Last Step*.
- *Last Step!*
- Now that there is laser light through the fiber and the rejection is better than 1:100, we must finally optimize the laser power. As above, use all 5 screws to maximize the power.
- Next, carefully loosen the translation screws that attach the 5-axis mount to the laser head. Loosen as little as possible so that the angle is not significantly changed and yet the 5-axis mount can still translate. While monitoring the output power, move the whole 5-axis mount relative to the laser beam until the power is maximized. It is often possible to get an additional 15  $\mu\text{W}$  of power using this “trick”. When the power is maximized, tighten the 5-axis mount back in place and fine tune with the 5 adjustment screws, if necessary.
- Goals:
  - The isolator will transmit roughly 60% of the laser power
  - The fiber will transmit roughly 60-70% of the power

With an ML-1 laser producing about 1.2 mW, it should be possible to achieve 400  $\mu\text{W}$  of power at the output end of the fiber.



## 5 VACUUM CHAMBER: Turbo Pump and Baking Out

Under normal operations, the vacuum in the dropping chamber is maintained by an ion pump. Any residual molecules in the chamber that enter the ion pump are ionized by the 4 kV potential and plated out, and thus the pressure in the chamber is directly proportional to the number of ionizations per second (i.e. the current drawn by the ion pump). Normal operation of the ion pump is indicated by 4 kV and a stable current of less than about  $3 \times 10^{-4}$  A (though it is normal for the current drawn to fluctuate with temperature).

This procedure only works at relatively high vacuum levels ( $\sim 10^{-6}$  mbar). If the vacuum has been degraded (i.e. the ion pump has been off for more than a few hours), it will be necessary to use the turbo pump to “regain” the vacuum. If the vacuum is very poor (ion pump off for many weeks, or the chamber has been opened to atmosphere), it will be necessary to bake (heat) the chamber while turbo pumping.

### 5.1 *Setting up the Turbo Pump*

Make sure the ion pump power is OFF. Remove the turbo pump from its case and place it near the dropping chamber vacuum flange. Connect the turbo pump to the dropping chamber using the flexible vacuum hose which has a vacuum flange on both ends. The vacuum hose is normally stored in the turbo pump case underneath the turbo pump. Make sure not to stress the bellow tube. See Figure 19.



**Figure 19. Turbo pump connected to dropping chamber. Note the minimum stress in the hose.**

Attach the vacuum hose to the turbo pump. The quick flange has a clamp which mates the two vacuum flanges with an o-ring seal. It is important to keep the o-ring seal and vacuum flanges free of dirt or scratches to avoid leaks.

Plug the turbo pump into the proper AC power. Make sure the small relief valve on the turbo pump vacuum flange is closed.

**Note** before turning on the power, it is very important to determine the status of the vacuum in the chamber! Depending on the vacuum level, the bellows valve (the opens from the vacuum hose into the vacuum chamber) should either be open or closed before turning on the turbo pump power.

- If the dropping chamber is under partial vacuum, the bellows valve should remain closed. Do not open this valve until the turbo pump has evacuated the air inside the flexible hose and come to full speed. (Otherwise air in the hose can be sucked into the chamber.) Full speed is indicated by the blinking green LED near the power switch, turning solid green. Once the turbo pump has reached a normal speed and normal operating pressure, slowly open the valve. It is important to open this valve slowly because if there is actually air in the chamber, a large amount of air can damage the turbo pump. Slowly turn the valve until it is completely open, all the while making sure that the turbo pump is still at full speed.



- If the dropping chamber is at full atmospheric pressure (i.e. the chamber was open for maintenance), the vacuum valve must be opened before starting the turbo pump. This will allow the roughing sequence of the turbo pump to remove the air from the hose and the chamber at the same time. This is important because the turbo-pump can be damaged if it is suddenly exposed to air when operating at its normal pumping speed. In general, the dropping chamber will also require a baking-out procedure to remove water vapor from the system. See Section 5.2 for details.

After the correct position for the bellows valve on the dropping chamber has been determined, turn the turbo pump power switch on. The roughing sequence of the pump will start immediately and then the turbo pump will slowly increase its speed. When the turbo-pump reaches its nominal operating speed (usually about 70-75 krpm), The small green LED on the side of the turbo pump will blink until the turbine has come to full speed, at which point it will be lit continuously.

Ideally, while pumping down the system, the AC power will not be interrupted. However, if the power is interrupted, the system will not actually vent to atmospheric pressure – the turbo pump has a valve that closes automatically in the event of a power outage. Of course, if possible, it is best to use an Uninterruptable Power Supply (UPS) while turbo pumping.

## **5.2 Baking Out the Dropping Chamber**

When the dropping chamber has been exposed to air or when the ion pump has been off for more than one month, it should be baked out while the turbo pump is operating. (**Note** while baking out, it is extremely important that the power to the ion pump remains OFF). Disconnect the high voltage cable from the ion pump.

Bake-out involves heating the dropping chamber and ion pump to “evaporate” water and other heavy molecules from the interior surfaces while the system is being turbo-pumped. This decreases the pumping time by speeding the out-gassing processes within the chamber. In cases where the ion pump has been off for several weeks, it may be helpful to bake out the chamber even though it has not been opened.

### **5.2.1 Heating the Chamber**

The magnets on the ion pump can be damaged by high temperatures and should be removed prior to baking out the Dropping Chamber. Remove the screws that hold the magnets in place, and then use a screwdriver to pry the magnets apart. Take care, as these magnets are quite strong. Once removed, keep the magnets away from each other.



To heat the chamber, wrap the heat tape around the ion pump and the chamber. Wrap tightly so that good thermal contact is maintained between the tape and the chamber. Make sure that the tape never wraps over itself – this will get extremely warm and can damage the tape. Also keep the heat tape away from the chamber bubble levels – they will be damaged if overheated. Finally, make sure the travel lock is engaged (this allows thermal contact between the test mass and the chamber). Turn on the power to the heat tape, and use a voltmeter with temperature mode to monitor the temperature (place the temperature sensor between the tape and the chamber to make sure that you are monitoring the hottest part). For the first 15 minutes or so, carefully monitor the temperature and adjust the heat tape current to maintain the temperature at about 60 – 70°. **The temperature of the chamber should never exceed 80°C as this can damage the ferrofluidic feedthrough.**

Once the heat tape has reached equilibrium at about 60°, and with the turbo pump on and evacuating the chamber, leave the heat on for at least 4-8 hours. Then turn the heat off, but leave the turbo pump on, letting the chamber cool for approximately 12 hours. A routine that works well is to start the chamber heat in the morning, monitor it throughout the day, turn the heat off at the end of the day, and let the turbo run (and the chamber cool) throughout the night. It should be ready for the ion pump the next day.

### 5.3 Starting the Ion Pump

At this point, the system should have cooled to room temperature. The dropping chamber should be under a good vacuum, the turbo pump should be operating at normal speed, and the ion pump should still be turned off. The next step is to migrate the system to the ion pump so that the turbo pump can be removed

If necessary, remove the heat tape from the system and replace the ion pump magnets. Attach the ion pump HV and safety ground cables to the chamber and the ion pump controller. Turn on the ion pump controller AC power, DC power (this charges the backup battery), and HV.

Monitor the ion pump voltage on the main display by selecting “kV”. Leave the turbo pump running and connected to the dropping chamber. Check that the voltage is increasing to approximately 4 kV (reading 4.0 on the “kV” scale) within five minutes after turning on the ion pump.

If the ion pump voltage has not reached the operating voltage within five minutes, turn off the power and continue pumping with the turbo pump for at least one hour before trying the ion pump again. Leaving the ion pump on with low voltage and excessive current significantly shortens the lifetime of the pump.

**NOTE** If the ion pump voltage immediately goes to 4 kV without “ramping up”, this could indicate a possible open in the ion pump circuit. This means the ion pump is at full voltage, but is not actually ionizing any molecules (i.e. it has not



started “pumping”), and the current it draws will be very near zero. In this situation **the ion pump is possibly not ready!** Leave the turbo pump on with the valve open at this point. Next take a hard object (i.e. a screwdriver) and gently, but firmly, tap the ion pump (not the controller). This can release molecules in the ion pump and start the ionizing process. If successful, you should see the ion pump voltage drop and then slowly ramp back up to near 4 kV. The current should now also be non-zero. This indicates that the ion pump is functioning. Then move on to the next step...

Once the ion pump has reached its operating voltage, monitor the ion pump current. This value should be approximately 0.1 – 1 mA and, if the vacuum is good enough, slowly falling as the ion pump ionizes less and less molecules (drawing less and less current). This means the ion pump is operating normally (though the turbo pump is still helping at this point).

If the voltage is stable, but the current continues to increase after 5 or so minutes, turn the ion pump off and wait approximately one hour before trying the ion pump again.

Once the ion pump has started and the current seems to be steadily decreasing, close the vacuum valve fully (but leave the turbo pump on). It is normal for the current to increase after the valve is closed, but after a few minutes it should begin decreasing again as the ion pump continues to pump. After the current has begun to decrease reliably (for 5 or so minutes), the turbo pump can finally be turned off.

After the turbo pump has come to a stop, use the relief valve on the turbo pump to re-fill the vacuum hose with air (and then close the valve so as to be ready for a future pump-down). Remove the hose from the chamber and turbo pump. Replace the blank flanges on the vacuum valve and turbo pump intake and remove the bellows tube. Replace the turbo pump in the shipping case; it will no longer be needed for operation.





## 6 Electronics Connections

Below is a list of the basic connections needed to measure gravity with the FG5. (Note that when shipped from the factory, the cables that connect the various FG5 electronic components are labeled.)

### 6.1 SIM

- Front
  - g ION (Ion Pump Current) ↔ Ion Pump Controller, METER MON
  - 1F Voltage (WEO 100 laser) ↔ WEO 100 Controller, METER Output
  - LASER LOCK (ML-1 laser) ↔ ML1 – Controller, LASER LOCK
  - LASER MODE (ML-1 laser) ↔ ML1 – Controller, LASER MODE
- Rear
  - ANALOG FRINGE IN ↔ FG5 Interferometer, ANALOG
  - TRIG OUT ↔ Magma PCI Unit, TIA Card, ARM
  - Ribbon Cable “g” ↔ Magma PCI Unit, “g” A2D Card
  - Ribbon Cable “TELE-g” ↔ Magma PCI Unit, “TELE-g” A2D Card
  - AUTOLEVEL (remote systems) ↔ FG5 Superspring Tripod Autolevel
  - 10 MHz Out ↔ Computer: CLOCK

### 6.2 Magma PCI Unit

- Rear
  - TIA Card, Arm ↔ SIM, Rear, TRIG OUT
  - TIA Card, CLK ↔ SIM, Rear, 10 MHz OUT
  - TIA Card, CHA ↔ FG5 Interferometer, TTL
  - “g” A2D Card, Ribbon Cable ↔ SIM Rear, “g”
  - “TELE-g” A2D Card, Ribbon Cable ↔ SIM Rear, “TELE-g”

### 6.3 Power Supply

- Front
  - IB Power (Green) ↔ FG5 Interferometer, Power
  - Superspring (Yellow) ↔ Superspring Chamber
  - Dropper Power (Blue) ↔ Dropper Chamber, Power
  - Dropper Encoder (Orange) ↔ Dropper Chamber, Encoder





## **7 Gravity Site Selection**

### **7.1 Geologic Stability**

To achieve best results, a site should be located in a geologically stable area. Generally, it may be necessary to measure gravity at a particular site for a number of different reasons, and geologic stability cannot be considered. However, when selecting a primary base station, geological stability is important in minimizing long term variations in gravity resulting from groundwater changes, and subsidence or rebound of the earth's crust.

### **7.2 Site Stability**

It is always best to select a site in the lowest level of a building to reduce vibrations as much as possible. A basement with a thick concrete floor is usually best. Avoid floors with composition materials, if possible, and set up the instrument on a solid tile or concrete floor.

### **7.3 Environmental Noise**

Heavy heating or cooling equipment, as well as bipedal or vehicular traffic, can cause vibrations which tend to increase the drop-to-drop scatter of the observations. This can usually be seen as a large, systematic change in the drop-to-drop scatter between day and night observations. A remote, environmentally quiet site usually minimizes these changes

### **7.4 Temperature Stability**

Although the FG5 will operate properly over a wide temperature range, it is important to have a site with good temperature stability to minimize possible problems with temperature sensitive components (e.g. laser and Superspring).

### **7.5 AC Power**

Problems with AC power are not uncommon, especially in remote field environments. Make sure that ground is available before plugging in system. It is always best to use voltage stabilizers and/or uninterruptible power supplies to minimize problems with unreliable line voltage. Some system components (e.g. the WEO Model 100 iodine laser) are more sensitive to line voltage fluctuations than others, so it is always best to stabilize line voltage well enough to satisfy the requirements of the most sensitive component.



## 8 System Specifications

### 8.1 Power

- 100 – 240V AC (all components, **with the exception of the WEO laser**, sense the line voltage automatically)
- Average load 350W

### 8.2 Weight and Dimensions XXXX

- Weight
  - IB & Laser 20 kg
  - Dropper 25 kg
  - Superspring 20 kg
  - Turbo Pump 15 kg
  - Dropper Tripod 20 kg
  - Superspring Tripod 12 kg
  - Electronics Rack 15 kg
  - Total 127kg
- Transit Case Dimensions (cm)
  - IB & Laser 64 x 56 x 38
  - Dropper 64 x 38 x 80
  - Superspring 31 x 30 x 57
  - Turbo Pump 37 x 37 x 47
  - Dropper Tripod 77 x 56 x 28
  - Superspring Tripod 64 x 56 x 31
  - Electronics Rack 51 x 65 x 10
  - Computer 38 x 32 x 7

### 8.3 Operating Temperature

- 15°C – 30°C (60°F – 90°F), internal temperature



## 9 Warranty

The warranty covering the FG5 Absolute Gravimeter is as follows:

Micro-g LaCoste, Inc. hereby warrants to purchaser that the instrument delivered hereunder shall be free of defects in material and workmanship appearing within one year from the date of delivery. Purchaser, or any third party purchaser, must give written notice of any defect covered by this warranty to seller within 13 months of the date of delivery of the instrument to purchaser. For any defect covered by this warranty, seller shall repair or replace defective components of the instrument on a timely basis at its sole expense provided that such warranty service shall be performed by seller at its facility in Lafayette, Colorado, U.S.A., and all cost of returning the instrument to seller shall be borne by purchaser. This warranty does not cover labor costs and other contingent expenses incurred by purchaser or a third party for the diagnosis of defects, and does not extend to the instrument if it has been (a) subject to misuse, neglect, accidents, acts of God or causes of a similar nature, or (b) altered by anyone other than seller without seller's prior approval. This warranty is in lieu of all other warranties except seller shall pass through any warranty issued by a manufacturer of any component part of the instrument and subrogate purchaser with respect to any claims thereunder.

This warranty is expressly conditioned on the following performance by the purchaser during the warranty period:

- I. In repairing or replacing component parts in the instrument, purchaser shall use only the following parts:
  - A. parts supplied by seller;
  - B. parts obtained from third parties to the extent such parts were made by the same manufacturer as the part being replaced; and
  - C. similar parts, upon prior written approval of seller, which approval shall not be unreasonably withheld.
- II. During the warranty period set forth above, purchaser shall give seller prompt notice of any and all problems associated with the operation or integrity of the instrument.



## 10 Checklists

### Setup

*For details on each step, please consult Section 3.*

- Place electronics box approximately 1 m from measurement location
- Check line voltage settings (especially for WEO laser)
- Check that ion pump is powered on and operating correctly. Connect to reliable AC power source.
- Make sure the FG5 Power Supply AC & DC power is off
- Make sure the WEO Controller switches (AC and HV) are set to OFF.
- Turn FG5 Power Supply AC power on.
- Place laser on stable surface, connect cables to WEO controller, turn on WEO controller and enable HV. The laser should emit laser light within a minute or so.
- Place Superspring tripod at measurement location. Orient the line from the center of the tripod to the bull's eye level along a North-South axis.
- Use tripod feet to center the bull's eye level.
- Measure and record the lower reference height
- Place and lock Superspring in tripod with travel lock oriented towards bull's eye level
- Level the Superspring tripod to the Superspring bubble levels
- Remove Superspring dust cap
- Place IB on top of Superspring with fiber optic oriented towards bull's eye level
- Assemble dropping chamber tripod
- Place dropping chamber tripod onto IB with the small hole in the tripod oriented towards the bull's eye level.
- Remove dust cap from IB
- Place dropping chamber into dropping chamber tripod with the ion pump oriented towards the beam-blocker side of the IB.
- Place the dropping chamber tripod feet under the tripod and adjust them until they are "just touching" the legs of the dropping chamber tripod
- Turning each foot one turn counter-clockwise one turn at a time, lift the dropping chamber two total turns
- Fine tune the level of the dropping chamber.
- If necessary, fine tune the level of the Superspring.
- Measure and record the upper reference height
- Un-travel lock the dropping chamber
- (Verify DC power is OFF) Connect the cables from the electronics to Superspring, IB, and dropping chamber.
- Un-travel lock the Superspring
- Turn on DC power



- If necessary, Zero the Superspring
- When spring motion has calmed down, enable Superspring Servo
- Check and adjust (if necessary) beam verticality
- Use Twiddler and lower mirror to maximize fringe signal (check with oscilloscope and OSC mode)
- Check and adjust (if necessary) beam verticality again
- Place dropper in DROP mode
- Verify that Rubidium clock has stabilized (RUB POWER light is steady ON)
- Turn on Magma Box if necessary
- Turn on laptop PC power
- Turn computer power ON and set up software
- Enter the total reference height and check all other parameters
- Take data



***Tear Down***

- Back up data (if applicable) and turn computer power OFF
- Travel lock Dropper
- Turn DC Power Off
- Turn off laser HV and AC power
- Turn AC Power off
- Travel lock Superspring
- Disconnect all cables (but get power to ion pump, and generally leave fiber optic connected between laser and IB)
- Unless shipping overseas, keep ion pump powered ON!
- Remove dropper (double check it is travel locked)
- Remove dropper tripod (and disassemble)
- Remove IB from Superspring and place it and laser in shipping box
- Remove Superspring (double check it is travel locked)
- Pack Superspring tripod