

**RHPS Series
RD(H)F40
User Manual**

Swagelok

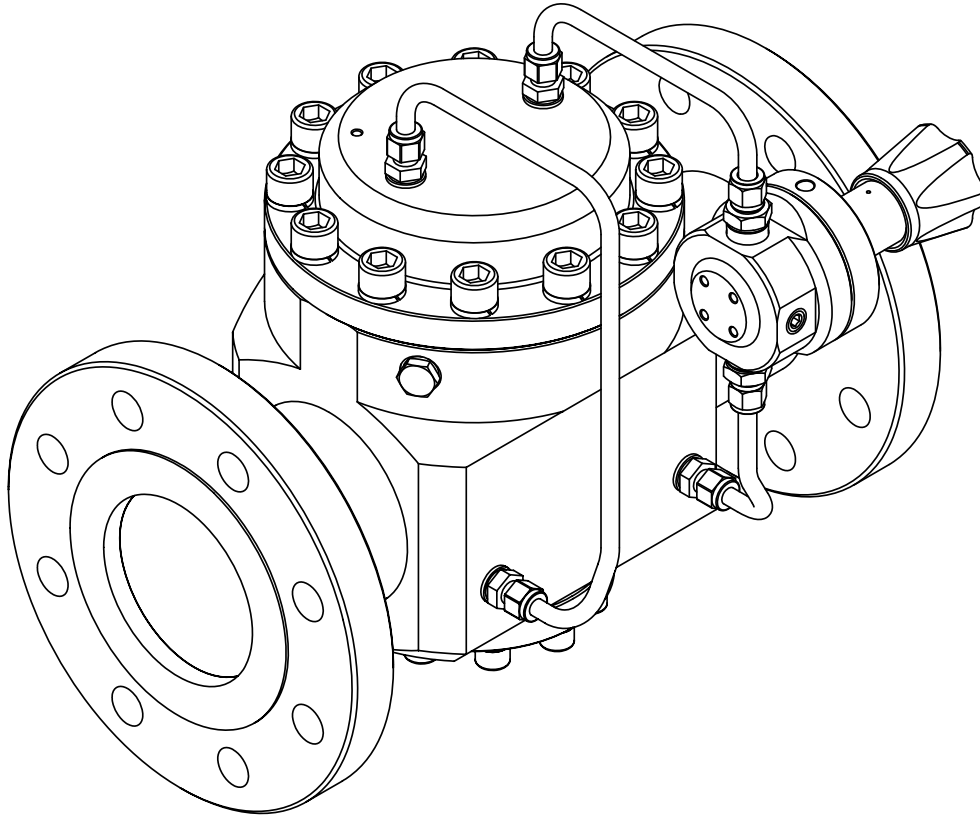

Read the complete manual before installing and using the regulator.



WARNING

Before removing a regulator from the system for service, you must

- depressurize system
- purge the system to remove any residual system media left in the regulator.

Contents

Introduction 3

Installation 4

Operation 7

Maintenance 8

Testing 9

Troubleshooting 9

Introduction

Representative drawing of the standard RD(H)F40

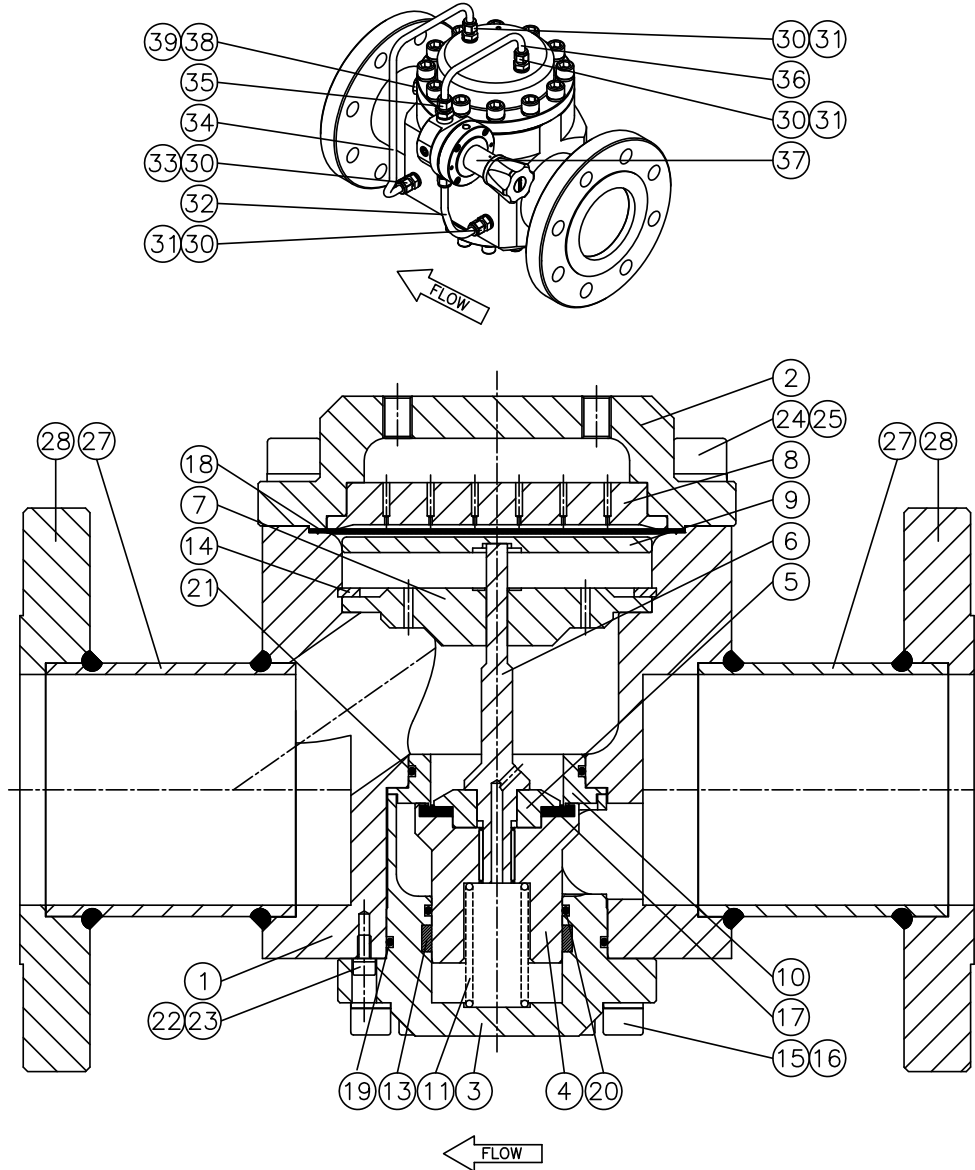

1	body	11	valve spring	22	ring	34	dynamic regulation tube
2	dome	13	guide ring	23	socket head cap screw	35	male connector
3	bottomplate	14	retaining ring	24	ring	36	tube 3/8"
4	valve case	15	ring	25	socket head cap screw	37	pilot regulator
5	valve case ring	16	socket head cap screw	27	tube	38	o-ring
6	valve stem	17	valve insert	28	flange	39	blindplug 1/4" bsp
7	bodyplate	18	diaphragm	30	bonded seal		
8	domeplate	19	o-ring	31	male connector		
9	diaphragmplate	20	o-ring	32	tube 3/8"		
10	seat	21	o-ring	33	bleedplug 1/4" bsp		

Installation



WARNING

When installing a Swagelok® self-venting regulator, position the vent connection or line away from operating personnel. Operating personnel must protect themselves from exposure to system fluids.



CAUTION

Do not use the regulators as a shutoff device.



CAUTION

When using the RDHF40 with an inlet pressure higher than 200 bar (2 902 psig), a safety valve must be installed in the outlet line, because the outlet pressure may not exceed 200 bar (2 902 psig).

Connections to System

The preferred mounting position of the regulator is horizontal with the dome facing upwards.

If grounding is required, connect a ground wire under a spring housing bolt.

Filling the dome

The dome can be filled using manual or electronic loading.

Manual loading:

1. This can be done by taking the gas pressure from the system and feeding this through a spring loaded pilot regulator into the dome. This is shown in sketch A.
2. In liquid systems the gas pressure for manual dome loading can be taken from a cylinder or mains. This is shown in sketch B.

Substituting the spring loaded pilot regulator for a proportional control valve and a pressure sensor, allows you to control the pressure electronically.

Electronic loading:

1. This can be done by taking the gas pressure from the system and feeding this through a proportional control valve into the dome. This is shown in sketch C.
This method can be used for low and medium pressure systems.
2. This can be done by taking the gas pressure from the system and feeding this through a proportional controlled ratio regulator into the dome. This is shown in sketch D.
This method can be used for high pressure systems.

The best results will be achieved by allowing a small flow to continuously pass through the pilot regulator.
 This flow can either be vented or, in gas systems, fed back through an orifice into the downstream piping.

This is usually referred to as “dynamic regulation”.



CAUTION

It is not recommended to place a gauge on the dome to set or check the outlet pressure. Because of forces in the regulator, the dome pressure will always be higher than the outlet pressure. Place a gauge in the outlet line to set or check the outlet pressure.

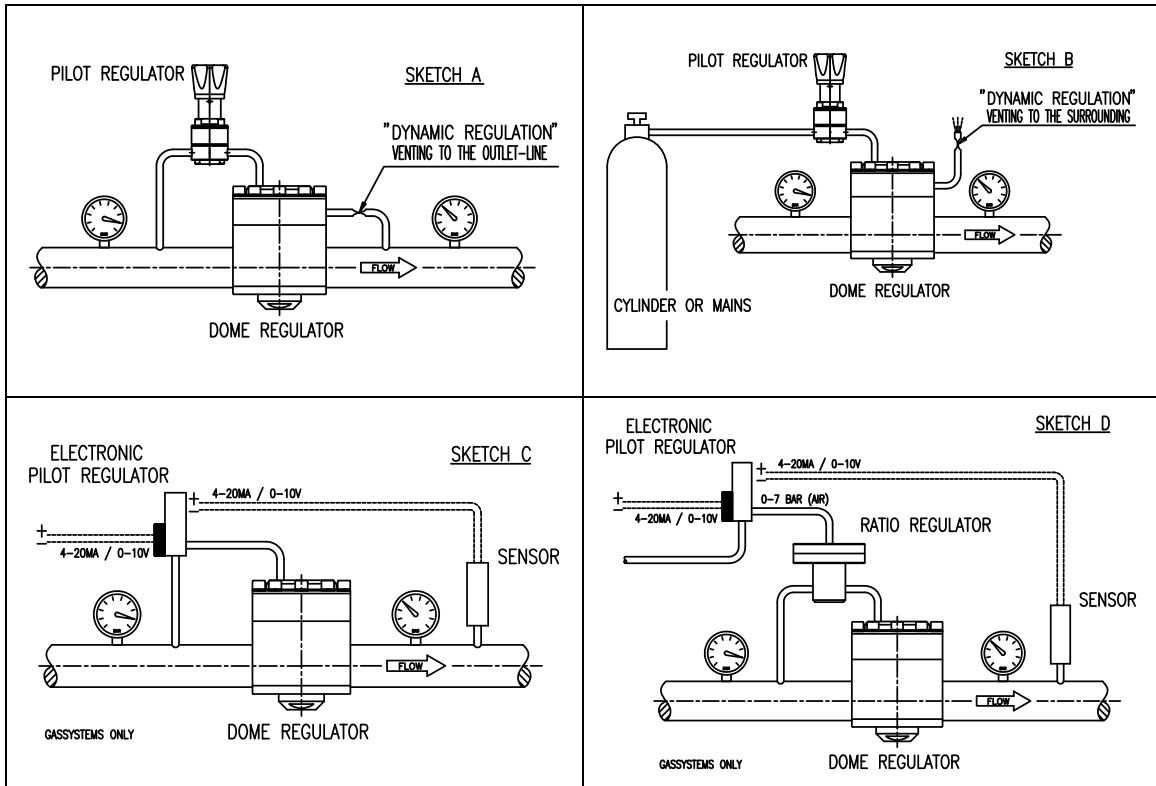

External feedback



CAUTION

When using the regulator with external feedback, option –EF, make sure that the outlet pressure can be fed back to the external feedback connection before applying pressure to the regulator. Failing to do so may lead to damage and non-functioning of the regulator as the inlet pressure will be put straight through to the outlet.

The purpose of the external feedback on a pressure regulator is to get a more accurate regulation of the outlet pressure. This can be achieved by sensing the outlet pressure downstream of the regulator and feeding it back to the regulator. For this purpose Swagelok has provided a special connection, marked on the regulator itself as "P2 feedback".

Connecting the external feedback

The external feedback must be installed as follows:

- The external feedback is to be connected in a turbulence-free zone in the downstream piping, at a maximum distance of 5x the outside diameter of the down stream piping.
- The external feedback must be connected on top of the downstream piping.
- The tube-size of the external feedback should be $\frac{3}{8}$ in. or $\frac{1}{2}$ in..



CAUTION

Never connect the external feedback line downstream of a shut-off valve.

Principle sketch of external feedback:

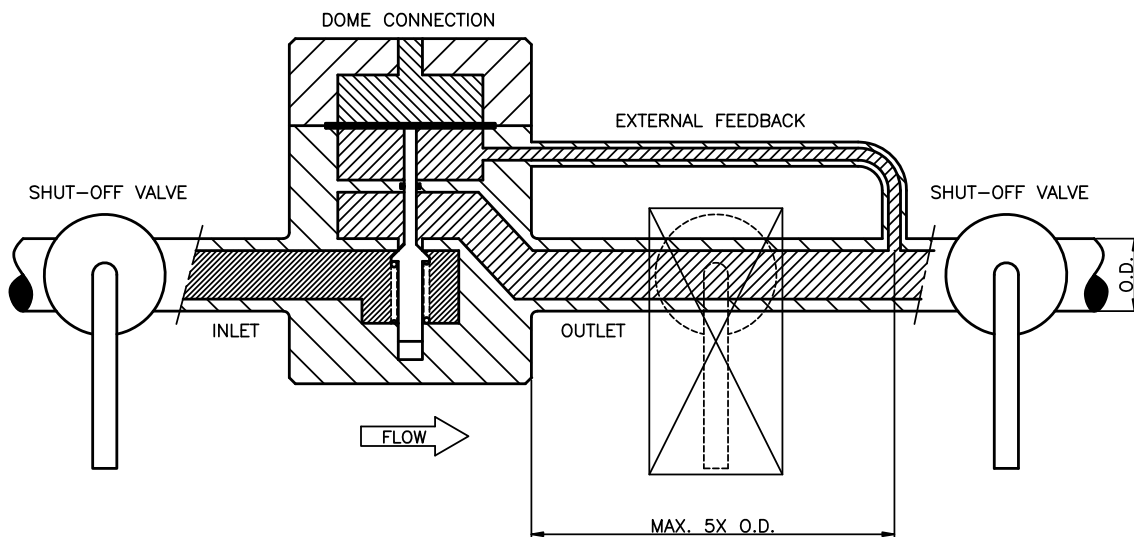

Operation

Note: All handle directions are when viewed from above.

- Inlet and set pressure settings are obtained by adjusting pressure in the dome.
 - Increase the pressure in the dome to increase the inlet pressure.
 - Decrease the pressure in the dome to decrease the inlet pressure.
- Icing of the regulator at high flow rates or high pressure drops may occur if the gaseous media or atmosphere contains moisture.
- An auxiliary upstream filter is recommended for use in all but the cleanest of media.
- Installation of a downstream pressure relief is recommended for regulator and system protection.
- If the shut-off valve at the outlet side is closed after changing the set pressure, the outlet pressure will rise a little because of the closing force required for bubble-tight closing of the regulator.
 - This phenomenon is usually referred to as the “**lock-up**” and does not indicate a problem with the regulator.
- A decrease in the flow will result in a rise of the outlet pressure.
 - An increase in the flow will result in a fall of the outlet pressure and is usually referred to as the “**droop**”.
 - This phenomenon does not indicate a problem with the regulator.
- A decrease of the inlet pressure will result in a rise of the outlet pressure.
 - An increase of the inlet pressure will result in a fall of the outlet pressure.
 - This phenomenon is usually referred to as the “**dependency**” or “supply pressure effect” and does not indicate a problem with the regulator.



CAUTION

If the pilot regulator also has changing inlet pressures, this will make the pressure difference in the outlet line of the dome regulator even bigger. This is because the pilot regulator will also increase its outlet pressure, which is the dome pressure. Any rise to the dome pressure will result in a rise of the outlet pressure.



CAUTION

When using the RD(H)F40 with an inlet pressure higher than 200 bar (2 902 psig), a safety valve must be installed in the outlet line, because the outlet pressure may not exceed 200 bar (2 902 psig).

Maintenance

Required tools for maintenance

- a vice to fasten the regulator
- pincers to take out the o-rings
- a pair of tongs for a retaining ring 140 mm
- a torque wrench
- a torque wrench hexagon head key 10 and 14
- media and temperature compatible lubricant for reassembling threaded parts
- media and temperature compatible lubricant for o-rings
- Snoop[®] liquid leak detector

Disassembly

- Loosen the hexagon socket head screws and remove the dome, dome plate, diaphragm and diaphragm plate.
- Loosen the hexagon socket head screws and remove the bottom plate, valve, valve spring and seat.

Inspection of disassembled parts

- Check all parts for abnormal wear. Replace parts in case of doubt.

Points of attention before assembly

- All parts must be clean and undamaged before starting assembly.
- Swagelok recommends replacing all o-rings and the diaphragm before assembly.
- All threaded parts must be lightly lubricated before assembly to avoid galling of threads.
- All o-rings need to be lightly lubricated to improve the lifetime of the o-ring and the performance of the regulator.

Assembly

Follow the points for disassembly in reverse order to assemble the regulator.

Recommended torques



CAUTION

Only tighten the bolts or parts if the regulator is completely depressurized.

- Hexagon socket head screws M12 50 N·m (442 in.·lb)
- Hexagon socket head screws M16 90 N·m (796 in.·lb)

Testing

Check the regulator for leakage across the seat, with low- and high inlet pressure.
Check the regulator for leakage across the diaphragm, with low- and high outlet pressure.

A well performing RD(H)F40 is 100 % bubble tight.
If there is a leakage across the seat or the diaphragm, the damaged parts must be replaced.

Troubleshooting

Problem:	The outlet pressure creeps up, without increasing the dome pressure.
Cause:	A damaged valve and/or seat.
Solution:	Replace the valve and/or the seat.

Problem:	Leakage around the bottom plate.
Cause:	A damaged o-ring or insufficient torque on the body plug.
Solution:	Replace the o-ring or tighten the bolts according to the torque specifications.

Problem:	Leakage between the body and the dome.
Cause:	A damaged diaphragm or insufficient torque on the bolts.
Solution:	Replace the diaphragm or tighten the bolts according to the torque specifications.

Problem:	Controlled pressure drops off sharply even when the flow is within regulator capabilities.
Cause:	The systems filter element is clogged.
Solution:	Replace the system filter element.

Problem:	The required set pressure can not be reached.
Cause:	The inlet pressure to the dome regulator or to the pilot regulator is not high enough.
Solution:	Make sure that the inlet pressure to the dome regulator and to the pilot regulator is sufficient.

Problem:	The outlet pressure rises too much when going from a dynamic to a static situation.
Cause:	There is too much flow in the dynamic situation.
Solution:	A larger regulator is required. Check the specific application data with the flow curves in our product literature, if available.

Problem:	The outlet pressure does not drop if the pressure in the dome is lowered.
Cause:	The valve is sticking.
Solution:	Replace the valve assembly.

Problem:	The outlet pressure has changed without adjusting the dome pressure.
Cause:	Changes to the inlet pressure will result in changes to the outlet pressure.
Solution:	Maintain a constant inlet pressure to the regulator. See section "operation" about dependency.

Warranty Information

*Swagelok products are backed by The Swagelok Limited Lifetime Warranty.
For a copy, visit swagelok.com or contact your authorized Swagelok representative.*

For additional information, see www.swagelok.com.

**Caution: Do not mix or interchange parts
with those of other manufacturers.**

Swagelok, Snoop – Swagelok Company
© 2010 Swagelok Company
December 2010, R0
MS-CRD-0184