

# MAINTENANCE BYPASS CABINET



*Wall-Mountable*



---

# TABLE OF CONTENTS

<b>IMPORTANT SAFETY INSTRUCTIONS</b> .....	<b>1</b>
<b>GLOSSARY OF SYMBOLS</b> .....	<b>2</b>
<b>1.0 GENERAL DESCRIPTION</b> .....	<b>3</b>
1.1 System Description .....	3
1.2 Features .....	3
1.3 Standard Components .....	3
<b>2.0 MODES OF OPERATION</b> .....	<b>5</b>
2.1 Bypass Switch .....	5
2.2 UPS Mode .....	5
2.3 Bypass Mode .....	6
<b>3.0 PREPARATION</b> .....	<b>7</b>
3.1 Inspection .....	7
3.2 Environment .....	7
3.3 Required Setup Equipment .....	7
3.4 Site Preparation .....	7
3.5 Mounting the Cabinet .....	8
<b>4.0 CABLE INSTALLATION</b> .....	<b>9</b>
4.1 Wiring Preparation .....	9
4.1.1 Preparing Internal Wiring .....	9
4.2 Dual Source Configuration .....	9
4.2.1 Removing the Cover Plates .....	10
4.3 Power Cable Installation .....	10
4.3.1 Input/Output Wiring (TB1) .....	11
4.3.2 Connection to GXT10000T .....	11
<b>5.0 OPERATING PROCEDURES</b> .....	<b>15</b>
5.1 Start-Up and Initialization .....	15
5.2 Shutting Down the UPS .....	15
5.3 Transferring System from UPS to Maintenance Bypass Operation .....	15
5.4 Transfer of the System from Maintenance Bypass to UPS Operation .....	15
<b>6.0 MAINTENANCE</b> .....	<b>16</b>
6.1 Proper Care .....	16
<b>7.0 SPECIFICATIONS</b> .....	<b>17</b>

---

## FIGURES

Figure 1	Front view . . . . .	4
Figure 2	Rear view . . . . .	4
Figure 3	Maintenance Bypass Cabinet in UPS Mode . . . . .	5
Figure 4	Maintenance Bypass Cabinet in Bypass Mode . . . . .	6
Figure 5	Wall-mount dimensions . . . . .	8
Figure 6	Wiring for dual sources . . . . .	9
Figure 7	Cover plate removal . . . . .	10
Figure 8	Connecting Maintenance Bypass to GXT10000T-208X . . . . .	12
Figure 9	Connecting Maintenance Bypass to GXT10000T-240X . . . . .	12
Figure 10	Maintenance Bypass Cabinet . . . . .	13
Figure 11	Connecting Nfinity to Maintenance Bypass . . . . .	14

## TABLES

Table 1	Dimensional data . . . . .	7
Table 2	Nfinity power cable and protection ratings . . . . .	10
Table 3	GXT 10kVA power cable and protection ratings . . . . .	11

---

## IMPORTANT SAFETY INSTRUCTIONS

---

### SAVE THESE INSTRUCTIONS

This manual contains important instructions that should be closely followed during installation and maintenance of this wall-mountable Maintenance Bypass Cabinet.

This product is designed for commercial/industrial use only. This product is not intended for use with life support and other designated “critical” devices. Maximum load must not exceed that shown on the UPS and the Maintenance Bypass Cabinet rating label.



### WARNING

Lethal voltages may be present within this unit even when it is apparently not operating. Observe all cautions and warnings in this manual. Failure to do so may result in serious injury or death. Never work alone.

The Maintenance Bypass Cabinet is designed for use on properly grounded (earthed) 208/240 VAC, 50 or 60Hz supply, for installation by qualified personnel. This UPS equipment is intended to be installed by a qualified / certified electrician who must review and approve customer supplied wiring, circuit breakers, intended loads and verify correct input, output and grounded (earthed) connections to ensure compliance with technical standards and national and local electrical codes. Installation instructions and warning notices are located in **4.0 - Cable Installation**.



### CAUTION

To reduce the risk of fire:

The NMBHW4x model must be connected to a circuit provided with 100A maximum branch circuit overcurrent protection in accordance with applicable national and local electrical codes.

The NMBHW8x model must be connected to a circuit provided with 125A maximum branch circuit overcurrent protection in accordance with applicable national and local electrical codes.

Operate the UPS equipment in an indoor environment only in an ambient temperature range of 32°F to 104°F (0°C to 40°C). Install it in a clean environment, free from conductive contaminants, moisture, flammable liquids, gases, or corrosive substances.

Never block or insert any object into the ventilation holes or other openings.

---

## GLOSSARY OF SYMBOLS

---



**Risk of Electrical Shock**



**Indicates Warning or Caution Followed by Important Instructions**

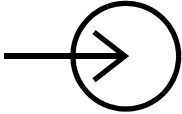

**AC Input**

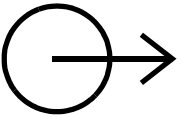

**AC Output**



**Requests the user to consult the manual**



**Equipment Grounding Conductor**



**ON**



**OFF**

## 1.0 GENERAL DESCRIPTION

---

Congratulations on your purchase of Liebert's wall-mountable Maintenance Bypass Cabinet. As with every Liebert product, we stand behind our quality. If you have any questions concerning this wall-mountable Maintenance Bypass Cabinet, please feel free to contact your local dealer, Liebert representative, or call the appropriate Technical Support number listed on the back of this manual.

To ensure proper installation and operation of this unit, please read this manual thoroughly.

Installation must be done by a qualified/certified electrician, but general operation may be performed without special training.

### 1.1 System Description

This wall-mountable Maintenance Bypass Cabinet is intended for use with the Nfinity, UPStation GXT 6&10 kVA, or any other UPS with equivalent specifications. Typical applications include supporting workstations, servers, network, telecom or other sensitive electronic equipment.

The Maintenance Bypass Cabinet was designed to provide maximum system availability to business critical equipment. The Maintenance Bypass Cabinet allows for transfer of connected loads to an alternate power path allowing full isolation of the UPS. The UPS can then be turned "OFF" and removed from service with no interruption of power to connected loads.

### 1.2 Features

- Supports up to 20 kVA loads
- High speed transfer switch
- Compact design
- Multiple power path indicators

### 1.3 Standard Components

- Easily accessible terminal blocks
- Wall-mountable
- Dual-source compatible for increased availability

Figure 1 Front view

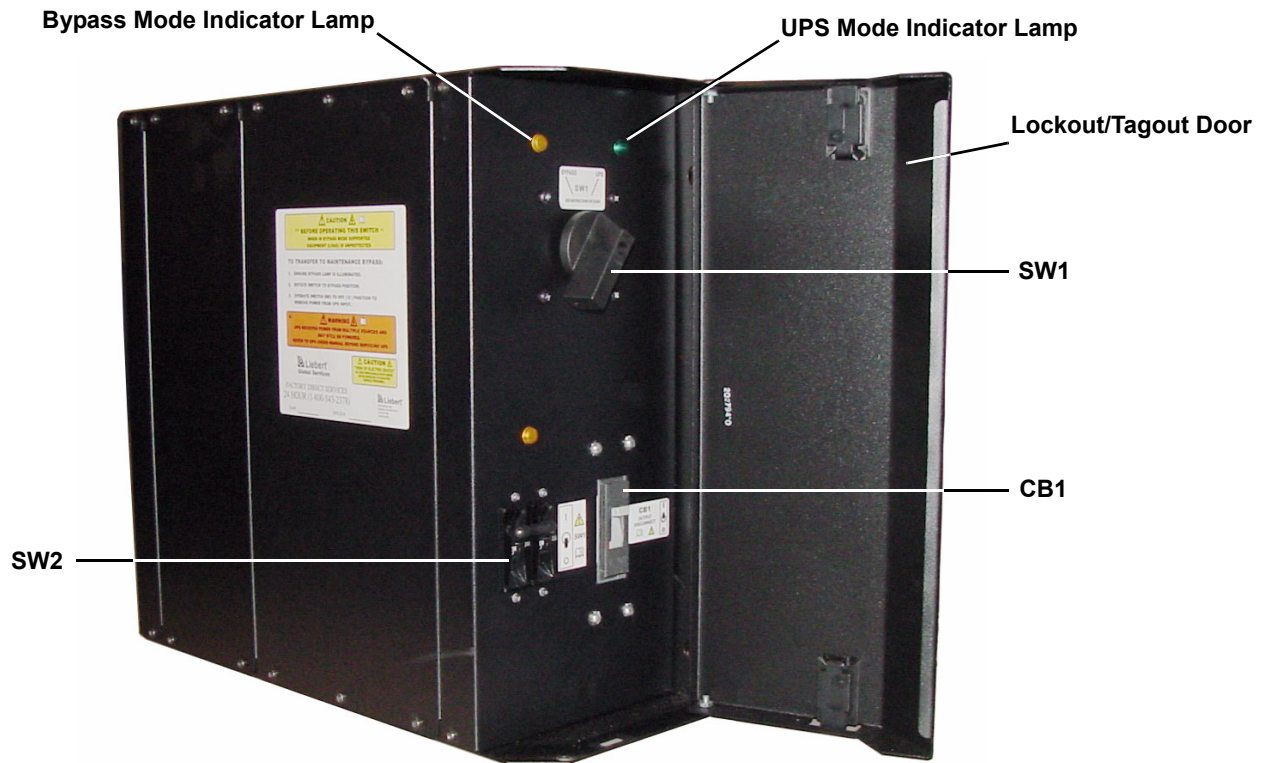
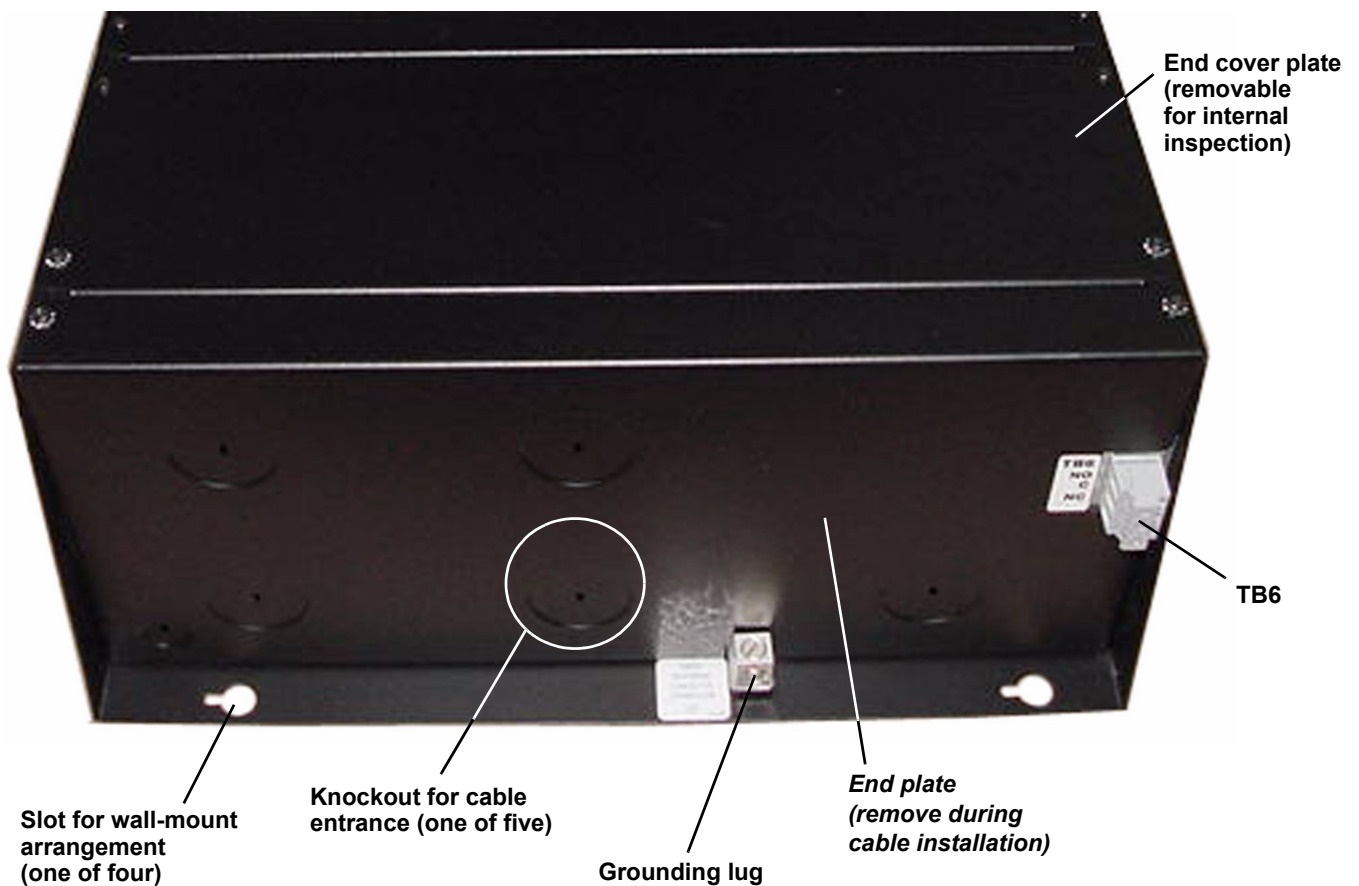

Figure 2 Rear view





---

## 2.0 MODES OF OPERATION

---

The Maintenance Bypass Cabinet is designed to operate in UPS mode and Bypass mode. The mode is selected using the Bypass Switch.

### 2.1 Bypass Switch

The Bypass Switch allows easy and rapid transfer of connected loads between the UPS and Bypass source.

### 2.2 UPS Mode

While the Maintenance Bypass Cabinet is in the UPS Mode, the UPS is supplying the connected load with continuous high quality AC power. In this mode of operation, the load is protected by the UPS. The Bypass Switch rotated toward the green lamp indicates this mode.

**Figure 3 Maintenance Bypass Cabinet in UPS Mode**

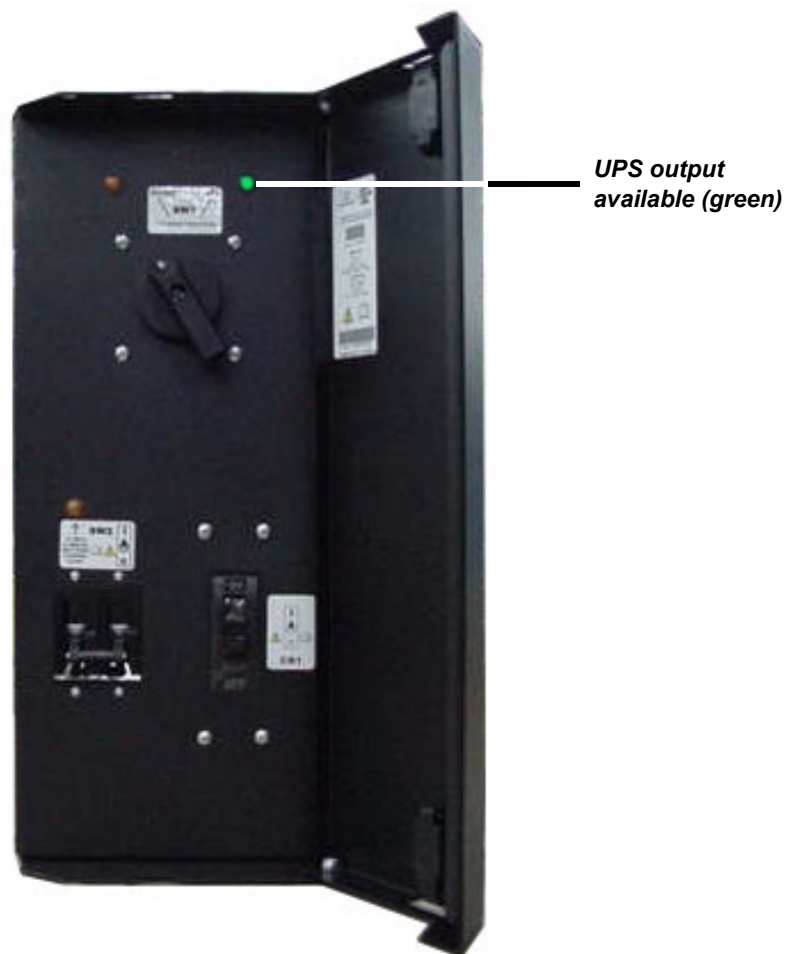

## 2.3 Bypass Mode

When the Maintenance Bypass Cabinet is in the Bypass mode it provides an alternate path for power to the connected equipment. Should the UPS need to be taken out of service for limited maintenance or repair, manual activation of the bypass will cause an immediate transfer of the equipment from the UPS inverter to the bypass source. The amber lamp illuminated in the Maintenance Bypass Switch compartment indicates bypass is available. In this mode of operation the load is NOT protected by the UPS. The Bypass Switch rotated toward the amber lamp indicates this mode. See **5.0 - Operating Procedures** for instructions on use.

**Figure 4 Maintenance Bypass Cabinet in Bypass Mode**



## 3.0 PREPARATION

These installation instructions provide all the information needed for positioning the Maintenance Bypass Cabinet (including environmental requirements) and for connecting the input and output power cables.

### 3.1 Inspection

Upon receiving the Maintenance Bypass Cabinet, examine the packaging for any signs of mishandling or damage. If any damage is noted, contact your local dealer or Liebert representative and notify your carrier.

### 3.2 Environment

The Maintenance Bypass Cabinet environment must be free of conductive contaminants and excessive moisture (water condensation), flammable vapors, chemical fumes, or corrosive gases and liquids.

### 3.3 Required Setup Equipment

The tools below are required in order to properly set up your Maintenance Bypass Cabinet:

- torque wrench
- flat-head screwdriver
- 3/16" (5 mm) Allen wrench
- T-20 Torx driver

### 3.4 Site Preparation

When deciding where to locate your Maintenance Bypass Cabinet, consider the weight and size of the unit. Make sure that the structural integrity of the wall can withstand the weight. Refer to the table below for dimensional considerations:

**Table 1 Dimensional data**

<b>Model</b>	NMBHWxx
<b>W x D x H In (mm)</b>	20 x 8 x 18 (508 x 203 x 457)
<b>Weight lbs, (kg)</b>	45 (20.5)

### 3.5 Mounting the Cabinet

This Maintenance Bypass Cabinet may be placed on the floor or mounted on a wall. In both cases, ensure that the unit is in a well-ventilated area with at least 12 inches (305 mm) clearance for access to the switches and cable connections.

When placing the cabinet on the floor, install the four rubber feet provided with the unit. One rubber foot goes on each corner of the the unit on the side where keyhole slots have been cut.

If the Maintenance Bypass Cabinet is to be mounted on a wall, you must install hardware to support the unit. Depending on the type of wall, you may need to install special anchors.

The Maintenance Bypass Cabinet has four keyhole-shaped slots to support it when mounted on a wall. To mount the unit:

1. Mark the wall where you will install the mounting hardware, either screws, anchors or bolts strong enough to support the unit (see **Wall-mount dimensions on page 8** for layout dimensions).
2. Insert the mounting screws, anchors or bolts, leaving enough clearance between the bolt heads and the wall to accommodate the Maintenance Bypass Cabinet's metal case.
3. Tighten the mounting bolts until they are snug, holding the Maintenance Bypass Cabinet firmly against the wall.

**Figure 5 Wall-mount dimensions**

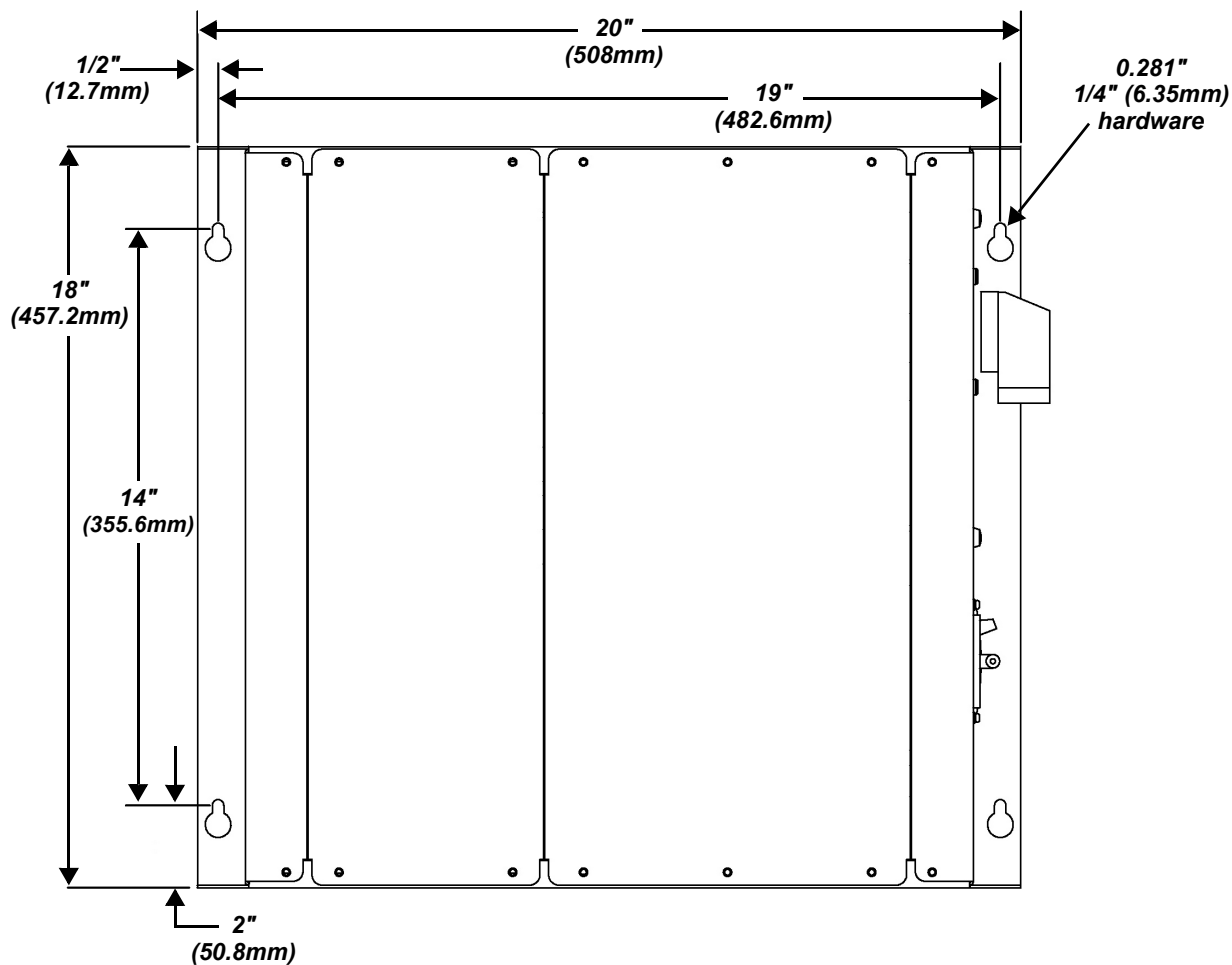

## 4.0 CABLE INSTALLATION

### 4.1 Wiring Preparation



## WARNING

Please read this section thoroughly before attempting to install wiring to this unit.

Be sure that the unit is not connected to any AC mains power source or UPS before installing any wiring to this unit. This Maintenance Bypass Cabinet should be installed by a qualified / certified electrician.

#### 4.1.1 Preparing Internal Wiring

The Maintenance Bypass Cabinet is factory-configured for single-source installations. If your installation requires dual-source capabilities, the Maintenance Bypass Cabinet's wiring must be modified.

### 4.2 Dual Source Configuration

Modifying the wiring consists of removing the jumpers between TB1 and TB2 as described below:

1. Remove cover plates.
2. Identify TB1 and TB2.
3. Using a 3/16" Allen wrench, loosen terminal mounting jumpers between TB1 and TB2.
4. Remove jumpers and retighten terminals to 22-26 in-lb (2.5 to 3.0 Nm).
5. Connect primary source to TB2 and secondary source to TB1.

Figure 6 Wiring modifications for dual inputs

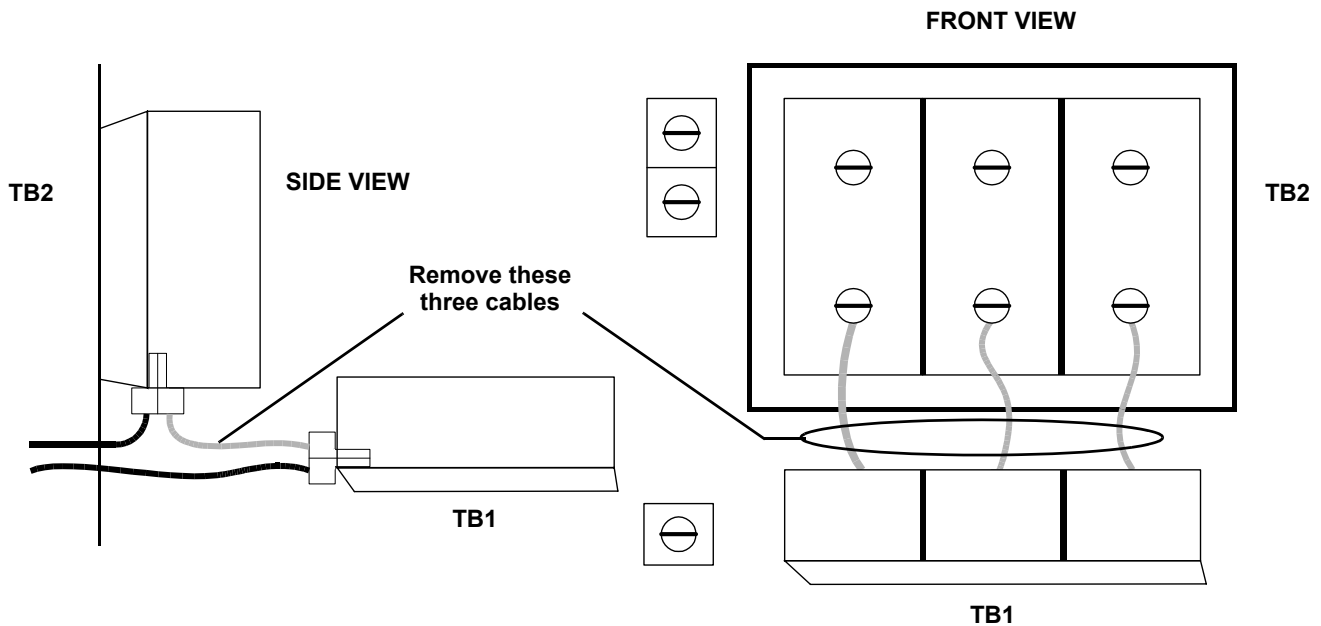

### 4.2.1 Removing the Cover Plates

Plates cover the input and output terminals on the back of the Maintenance Bypass Cabinet (see illustration below). Remove these using a T-20 Torx screwdriver. Keep screws and plates to one side.

Figure 7 Cover plate removal

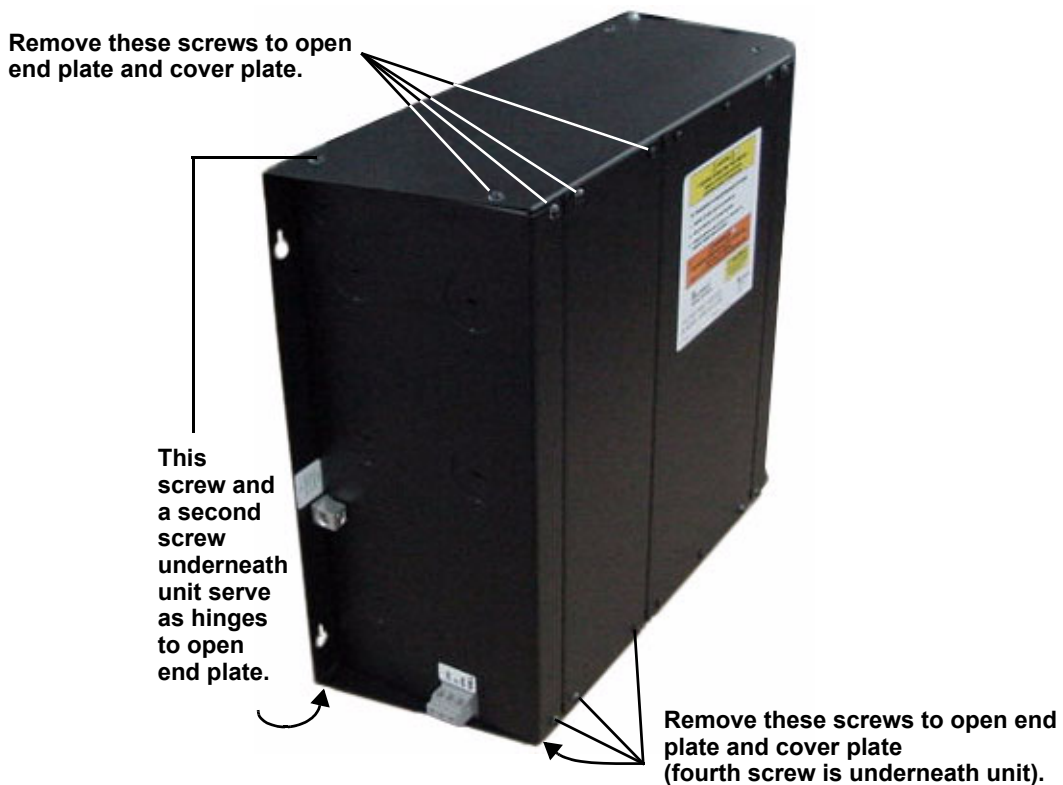

### 4.3 Power Cable Installation

Refer to **Table 2** when selecting cables:

**Table 2** Nfinity power cable and protection ratings

Model NMBHW4x	
Max Input Current	100 A
Input Protection	100 A
Max Output Current	100 A
Input/ Output Terminal Details	Max: 2/0 (70 mm <sup>2</sup> ) Min: 6 AWG (16 mm <sup>2</sup> )
Model NMBHW8x	
Max Input Current	125 A
Input Protection	125 A
Max Output Current	125 A
Input/ Output Terminal Details	Max: 2/0 (70 mm <sup>2</sup> ) Min: 6 AWG (16 mm <sup>2</sup> )



#### NOTE

*Transient and steady state earth leakage currents may occur when starting the equipment. This should be taken into account when selecting ground current detection devices, as these will carry the earth leakage currents of both the UPS equipment and the load.*

### 4.3.1 Input/Output Wiring (TB1)

Follow the steps below to connect the input wiring:



#### NOTE

*Input wiring must be installed using conduit.*

*208 input voltage jumper—if only the connections for 208 VAC are made between the UPS and the Maintenance Bypass, the 208 input voltage jumper must be installed for proper operation. To install this jumper, place the jumper wire provided in the accessory kit between Pin 1 and Pin 2 on TB4.*

1. Locate the input wiring access, remove the knockout and pull the three/four input wires through it, allowing some slack for installation.
2. Secure the conduit to the rear panel of the Maintenance Bypass Cabinet.
3. Input power cables connect to hex terminals on the input terminal block.
4. Insert the ground (earth) wire through the earth lug and tighten it to the proper torque value (22-26 in-lb). Then connect the wires to the block connections as shown below. Using a torque wrench, turn the screws clockwise until tightened to the proper torque value (22-26 in-lb).

### 4.3.2 Connection to GXT1000T

#### Wiring Preparation



#### WARNING

Please read these instructions thoroughly before attempting to connect any wiring to this unit.

Ensure that the unit is not connected to any AC utility power source or UPS before connecting any wiring to this unit. Wiring connections should be performed only by a qualified/certified electrician.

#### Power Cable Installation

Refer to **Table 3** and subsequent illustrations when selecting cables.

**Table 3 GXT 10kVA power cable and protection ratings**

	208V	240V
Max Input Current	45A	44A
Input Protection	60A	60A
Max Output Current	43A	42A
Terminal Block Details	Max: 35 mm <sup>2</sup> (2/0 AWG) Min: 16 mm <sup>2</sup> (6 AWG)	



#### NOTE

*Transient and steady state earth leakage currents may occur when starting the equipment. This should be taken into account when selecting ground current detection devices, as these will carry the earth leakage currents of both the UPS equipment and the load.*

Figure 8 Connecting Maintenance Bypass to GXT10000T-208X

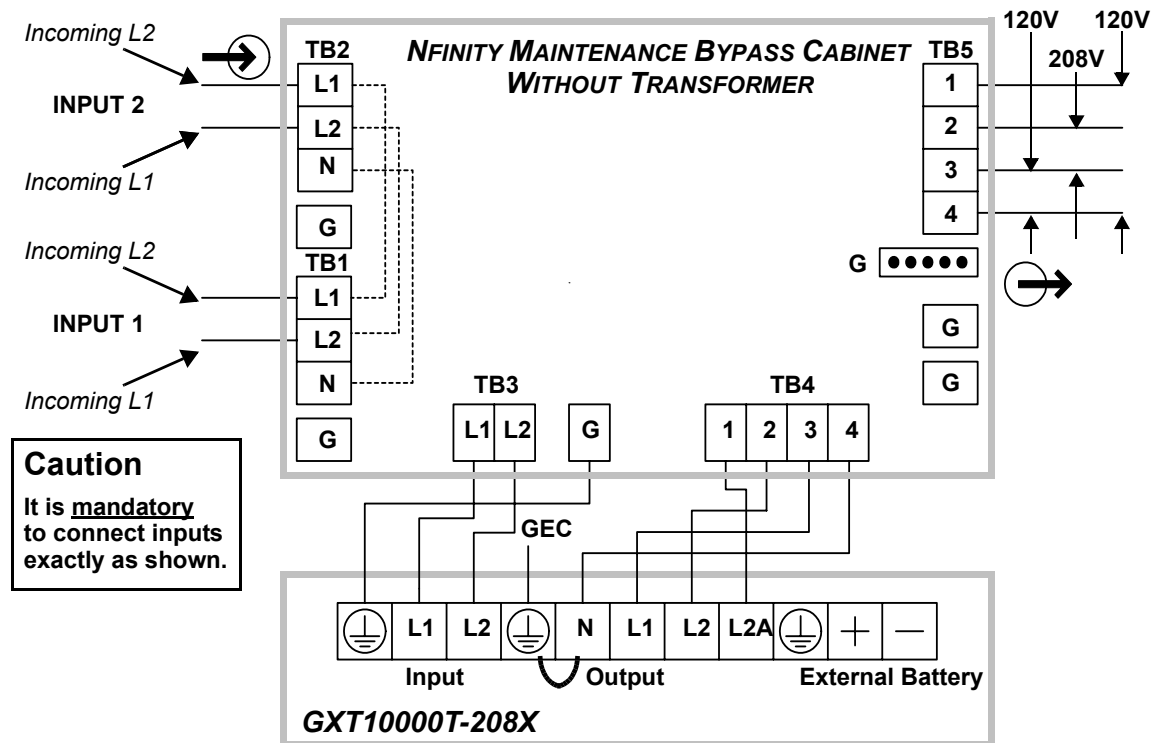
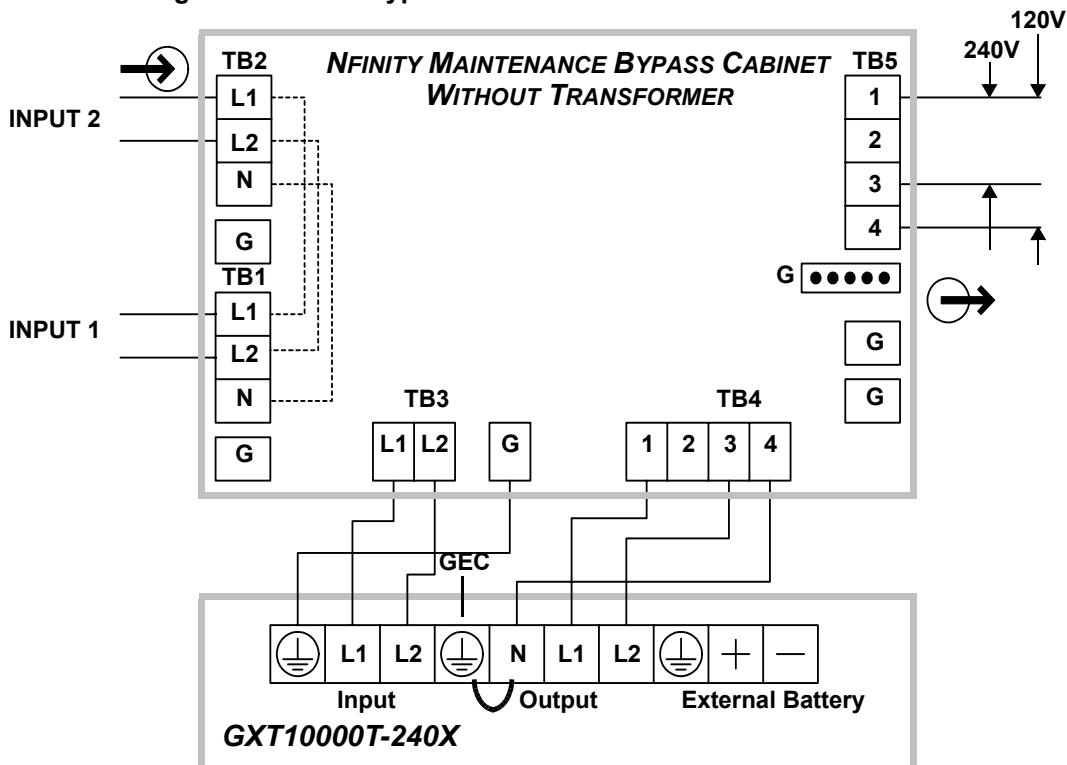

Figure 9 Connecting Maintenance Bypass to GXT10000T-240X



**NOTES**

1. **SINGLE-SOURCE FEED**—If feeding the Maintenance Bypass Cabinet from a single source, the input connection may be made to either TB1 or TB2.
2. **DUAL-SOURCE FEED**—If feeding the Maintenance Bypass Cabinet from a dual source, the UPS input supply connection must be made to TB1 and the bypass input supply connection must be made to TB2. The link between TB1 and TB2 must be removed.



Figure 10 Maintenance Bypass Cabinet

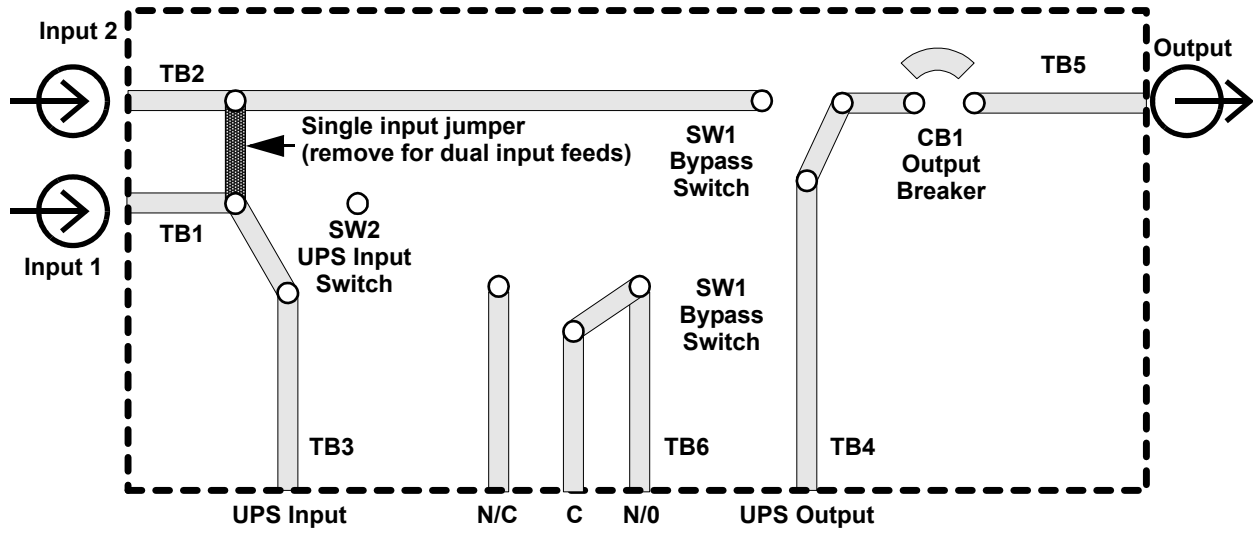
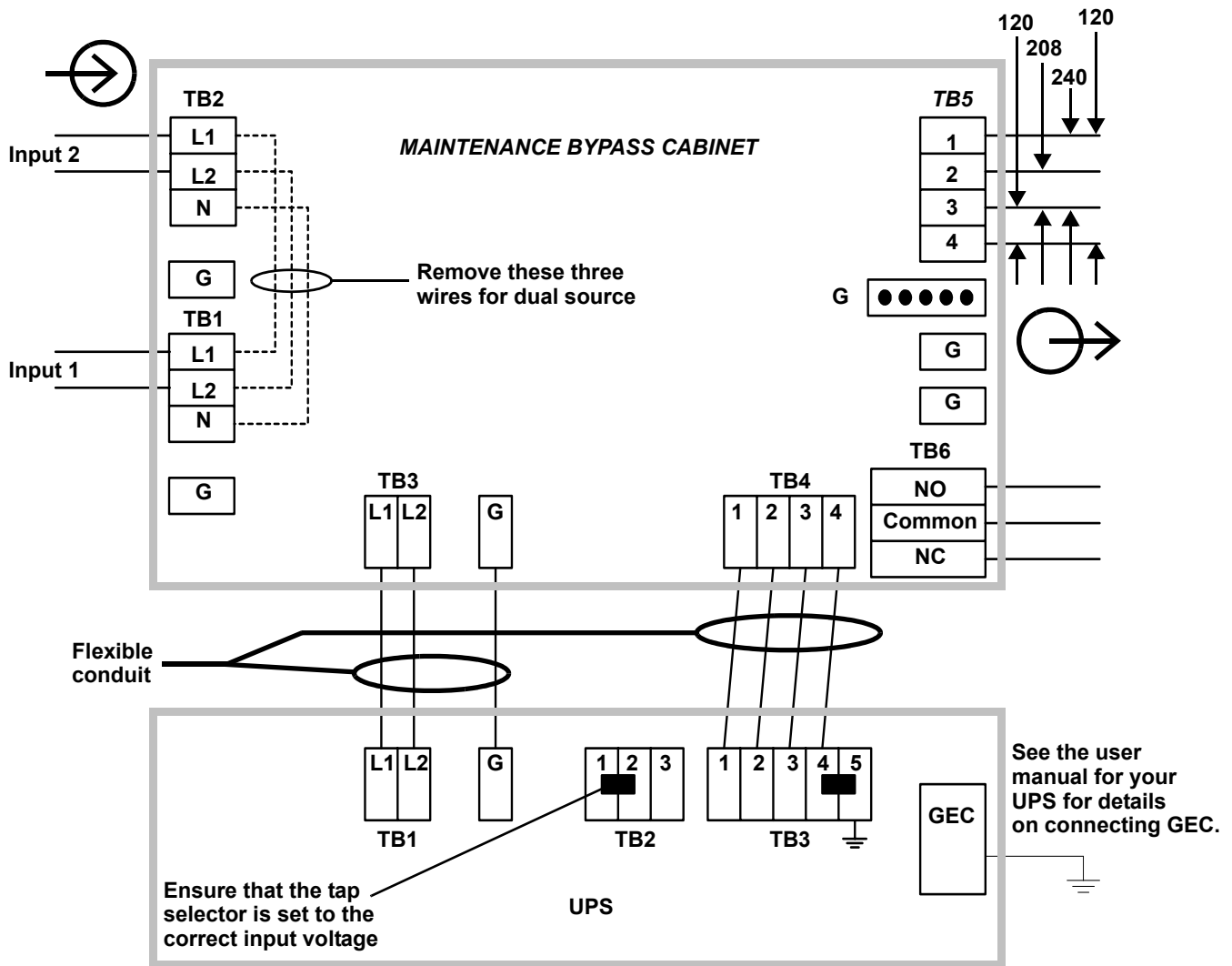

Figure 11 Connecting Nfinity to Maintenance Bypass



**NOTE**

1. If feeding the Maintenance Bypass Cabinet from a single source, the input connection may be made to either TB1 or TB2.
2. If feeding the Maintenance Bypass Cabinet from a dual source, the UPS input supply connection must be made to TB1 and the bypass input supply connection must be made to TB2. The link between TB1 and TB2 must be removed.
3. TB6 provides Normally Open and Normally Closed contacts to indicate operation of the bypass switch.

Maintenance Bypass Switch Position	TB6 Contacts	
Bypass	NO - Common: Open	NC - Common: Closed
UPS	NO - Common: Closed	NC - Common: Open

## **5.0 OPERATING PROCEDURES**

---

### **5.1 Start-Up and Initialization**

Follow these steps to start up the UPS while connected to the Maintenance Bypass.

1. Set Maintenance Bypass switch (SW1) to UPS position on Maintenance Bypass Cabinet.
2. Close UPS source switch (SW2).
3. Close output circuit breaker (CB1).
4. Close input circuit breaker (CB1).
5. On UPS, close control enable switch (SW2).
6. After UPS has initialized, turn UPS output on by pushing the standby button.

### **5.2 Shutting Down the UPS**

Use the following procedure to power down the system.

1. Turn UPS output off by pushing the Standby button.
2. Open the control enable switch (SW2) on the UPS.
3. Open the input circuit breaker (CB1) on the UPS.
4. Open the UPS source switch (SW1) on the Maintenance Bypass Cabinet.
5. Open the output circuit breaker (CB1) on the Maintenance Bypass Cabinet.

### **5.3 Transferring System from UPS to Maintenance Bypass Operation**

1. Verify that the amber bypass lamp is illuminated
2. Turn the bypass switch (SW1) to the bypass position on the Maintenance Bypass Cabinet. The connected equipment is now powered from the bypass source and is not protected.

### **5.4 Transfer of the System from Maintenance Bypass to UPS Operation**

1. Close the UPS source switch (SW1) on the Maintenance Bypass Cabinet.
2. Close the input circuit breaker (CB1) on the UPS.
3. Close the control enable switch (SW2) on the UPS.
4. Turn the UPS output on by pushing the standby button on the UPS. Verify the Green UPS lamp is illuminated.
5. Turn the bypass switch to the bypass position on the Maintenance Bypass Cabinet.

## **6.0 MAINTENANCE**

---

### **6.1 Proper Care**

Keeping your Liebert Maintenance Bypass Cabinet operating properly is imperative to optimal performance and life of the unit. It is recommended that a certified technician perform preventive and corrective maintenance.

Liebert Global Services (LGS) is dedicated to ensuring the highest level of performance and unmatched support for your Maintenance Bypass Cabinet. Contact an LGS representative for services to guarantee maximum reliability and system availability.

## 7.0 SPECIFICATIONS

<b>General &amp; Environmental</b>			
Unit Rating	NMBHW4x = 16kVA		
	NMBHW8x = 20kVA		
	NMBHW4x = 100A max		
	NMBHW8x = 125A max		
Compliant Safety Standards	UL 1778, c-UL		
<b>Mechanical</b>			
Dimensions, WxDxH, in. (mm)	20 x 8 x 18 (508 x 203 x 457)		
Weight	45 lb. (20.5 kg)		
<b>Environmental</b>			
Operating Temperature, maximum	32° - 104°F (0° - 40°C)		
Relative Humidity	5 - 95% noncondensing		
Operating Altitude, maximum	10,000 ft.; (3,000m)		
<b>Input Data</b>			
Nominal Input Voltage	208 or 240VAC		
Input Frequency, nominal	50 or 60Hz		
Input Frequency Range	45-55Hz or 55-65Hz		
<b>Output Data</b>	<b>208/240</b>	<b>240</b>	<b>208</b>
Output Voltage, VAC	120/120/208/240	120/120/240	120/120/208
Transfer Time	<4 msec typical		
Output Frequency	50 or 60Hz (same as input)		
<b>TB6 Contacts</b>			
Maximum Voltage	120VAC		
Maximum Current	5A		





# Maintenance Bypass Cabinet

## USER MANUAL

### The Company Behind the Products

With over a million installations around the globe, Liebert is the world leader in computer protection systems. Since its founding in 1965, Liebert has developed a complete range of support and protection systems for sensitive electronics:

- Environmental systems—close-control air conditioning from 1 to 60 tons
- Power conditioning and UPS with power ranges from 300 VA to more than 1000 kVA
- Integrated systems that provide both environmental and power protection in a single, flexible package
- Monitoring and control—from systems of any size or location, on-site or remote
- Service and support through more than 100 service centers around the world and a 24/7 Customer Response Center

While every precaution has been taken to ensure the accuracy and completeness of this literature, Liebert Corporation assumes no responsibility and disclaims all liability for damages resulting from use of this information or for any errors or omissions.

© 2003 Liebert Corporation

All rights reserved throughout the world. Specifications subject to change without notice.

® Liebert and the Liebert logo are registered trademarks of Liebert Corporation. All names referred to are trademarks or registered trademarks of their respective owners.

SL-23967 (11/03) Rev. 1

### Technical Support/Service

#### Web Site

[www.liebert.com](http://www.liebert.com)

#### Monitoring

800-222-5877

[monitoring@liebert.com](mailto:monitoring@liebert.com)

Outside the US: 614-841-6755

#### Single-Phase UPS

800-222-5877

[upstech@liebert.com](mailto:upstech@liebert.com)

Outside the US: 614-841-6755

#### Three-Phase UPS

800-543-2378

[powertech@liebert.com](mailto:powertech@liebert.com)

#### Environmental Systems

800-543-2778

#### Outside the United States

614-888-0246

#### Locations

##### United States

1050 Dearborn Drive

P.O. Box 29186

Columbus, OH 43229

##### Italy

Via Leonardo Da Vinci 8

Zona Industriale Tognana

35028 Piove Di Sacco (PD)

+39 049 9719 111

Fax: +39 049 5841 257

##### Asia

23F, Allied Kajima Bldg.

138 Gloucester Road

Wanchai

Hong Kong

+852 2 572 2201

Fax: +852 2 831 0114