

# TYLER

SPECIALTY  
PRODUCTS

## Installation & Service Manual



### NSSD

**THREE DECK MEAT/DELI/CRITICAL TEMP  
PRODUCE MERCHANDISERS WITH CURVED FRONT GLASS  
Medium Temperature Self Serve Display Cases**

**This manual has been designed to be used in conjunction with the General  
(UL/NSF) Installation & Service Manual.**

**Save the Instructions in Both Manuals for Future Reference!!**

This merchandiser conforms to the American National Standard Institute & NSF International Health and Sanitation standard ANSI/NSF 7 - 1999.

PRINTED IN U.S.A.	Specifications subject to change without notice.	REPLACES EDITION	3/02	ISSUE DATE	10/02	PART NO.	9037171	REV.	A
-------------------	--	------------------	------	------------	-------	----------	---------	------	---

**CONTENTS**

	<u>Page</u>
<b>Specifications</b>	
NSSD Specification Sheets . . . . .	4
Line Sizing Requirements . . . . . (See General-UL/NSF I&S Manual)	
<b>Pre-Installation Responsibilities . . . . . (See General-UL/NSF I&amp;S Manual)</b>	
<b>Installation Procedures</b>	
<b>Carpentry Procedures . . . . .</b>	<b>6</b>
Case Pull-Up Locations . . . . .	6
<b>Plumbing Procedures . . . . . (See General-UL/NSF I&amp;S Manual)</b>	
<b>Refrigeration Procedures . . . . . (See General-UL/NSF I&amp;S Manual)</b>	
<b>Electrical Procedures . . . . .</b>	<b>6</b>
Electrical Considerations . . . . .	6
<b>Defrost Information . . . . .</b>	<b>7</b>
Defrost Control Chart . . . . .	7
<b>Installation Procedure Check Lists (See Gen.-UL/NSF I&amp;S Manual)</b>	
<b>Wiring Diagrams . . . . .</b>	<b>7</b>
<b>NSSD Domestic &amp; Export (50Hz) Case Circuits . . . . .</b>	<b>8</b>
<b>Cleaning and Sanitation</b>	
<b>Component Removal and Installation Instructions for Cleaning</b>	<b>12</b>
Shelves and Shelf Brackets . . . . .	12
Bottom Trays . . . . .	12
Front Air Ducts . . . . .	12
Rear Duct Panels . . . . .	12
Discharge Air Honeycomb . . . . .	12
Front Lower Cladding . . . . .	12
Front Upper Cladding . . . . .	13

	<u>Page</u>
<b>General Information</b>	
<b>NSF Product Thermometer</b> .....	13
<b>Radiant Heat Information</b> .....	13
Radiant Heat Measurement .....	14
Display Practices .....	14
<b>Service Instructions</b>	
<b>Preventive Maintenance</b> .....	(See General-UL/NSF I&S Manual)
<b>Light Servicing</b> .....	14
Ballast and Lighting Locations .....	14
Ballast Replacement .....	15
<b>Defrost Heater Replacement</b> .....	15
<b>Fan Blade and Motor Replacement</b> (See Gen.-UL/NSF I&S Manual)	
<b>Color Band and Bumper Replacement</b> (See Gen.-UL/NSF I&S Man.)	
<b>Anti-Sweat Replacement</b> .....	16
Top Light Channel Anti-Sweat Replacement .....	16
<b>Front Curved Plexiglas Replacement</b> .....	16
<b>Parts Information</b>	
<b>Operational Parts List</b> .....	17
<b>Cladding and Trim Parts Lists</b> .....	18
<b>TYLER Warranty</b> .....	(See General-UL/NSF I&S Manual)

The following Medium Temperature, Top Display Meat, Deli and Critical Temp Produce Merchandiser models are covered in this manual:

MODEL	DESCRIPTION
NSSD	6', 8' & 12' CURVED GLASS FRONT 3-DECK MEAT/DELI MERCHANDISER

**SPECIFICATIONS**

**NSSD Three Deck Meat/Deli/Critical Temp Produce Merchandisers**

<b>MODEL</b>	NSSD (2 SHELF ROWS)	NSSD (3 SHELF ROWS)
<b>USAGE</b>	MED TEMP	MED TEMP
<b>CAPACITY (BTUH/FT)*</b>	964	1078
<b>EVAPORATOR***</b>	+15F	+15F
<b>ENTER AIR°</b>	+27F	+27F

**NOTES:**

\* Capacity data listed is for cases with 1 row of T-8 canopy lights and optional T-8 lighted shelves. Adjustments must be made to this base rating for each option installed on the case.

\*\* Evaporator temperature is defined as the saturated suction temperature leaving the case.

FOR ENERGY CALCULATION DATA REFER TO THE ENERGY SECTION. FOR COMPRESSOR SIZING INFORMATION REFER TO THE "GOLD" SECTION & FOR LINE SIZING INFORMATION REFER TO THE "BUFF" SECTION OF THE TYLER SPECIFICATION GUIDE.

**CAPACITY ADJUSTMENTS:**

DEDUCT 20 BTUH/FT per row of unlighted shelves, when NOT using Lighted Shelves.

208 VOLT DEFROST (AMPS)													
FT	6	8	12	16	20	24	28	32	36	40	44	48	52
1 PH	6.5 TG-30	6.9 TG-30	10.3 TG-30	13.8 TG-30	17.2 TG-30	20.6 TG-30	24.1 TG-40	27.5 TG-40	30.9 TG-40	34.4 TG-50	37.8 TG-50	41.2 TG-50	44.7 TG-50
3 PH	N/A	N/A	N/A	12.0 TG-3 -30	15.0 TG-3 -30	18.0 TG-3 -30	15.0 TG-3 -30	18.0 TG-3 -30	18.0 TG-3 -30	21.0 TG-3 -30	25.0 TG-3 -40	28.0 TG-3 -40	30.0 TG-3 -40
CASE-TO-CASE SUCTION LINE SUB-FEED BRANCH LINE SIZING													
R22	1/2"	5/8"	5/8"	7/8"	7/8"	7/8"	7/8"	7/8"	1 1/8"	1 1/8"	1 1/8"	1 1/8"	1 1/8"

DEFROST CONTROL				EPR SETTINGS††	
PER DAY	MODE	TIME	TERM.	R22	R404A
6	TIME OFF	28 MIN.		38#	50#
6	ELECT	36 MIN.	50F		
6	HOT GAS	12-15 MIN.	55F†		

† If an Electronic Sensor is used for termination, it should be set at 70°F termination temperature. The sensor must be located in the same location as the defrost termination klixon for that defrost type.

†† Set EPR to give this pressure at the case.

**DEFROST CIRCUITS:** OFF CYCLE defrost is standard (use TC defrost module) - **OPTIONAL ELECTRIC** defrost uses a single or 3 phase circuit - **OPTIONAL HOT GAS** defrost uses 2 control wires @ 208V per lineup.

**CASE BTUH REQUIREMENTS** are calculated to produce approximately the indicated entering air temperature with absolute maximum operating ambient limits of **75F & 55RH**.

The information contained herein is based on technical data and tests which we believe to be reliable and is intended for use by persons having technical skill, at their own discretion and risk. Since conditions of use are outside Tyler's control, we can assume no liability for results obtained or damages incurred through the applications of the data presented. SPECIFICATIONS ARE SUBJECT TO CHANGE WITHOUT NOTICE.

NSSD Three Deck Meat/Deli/Critical Temp Produce Merchandisers

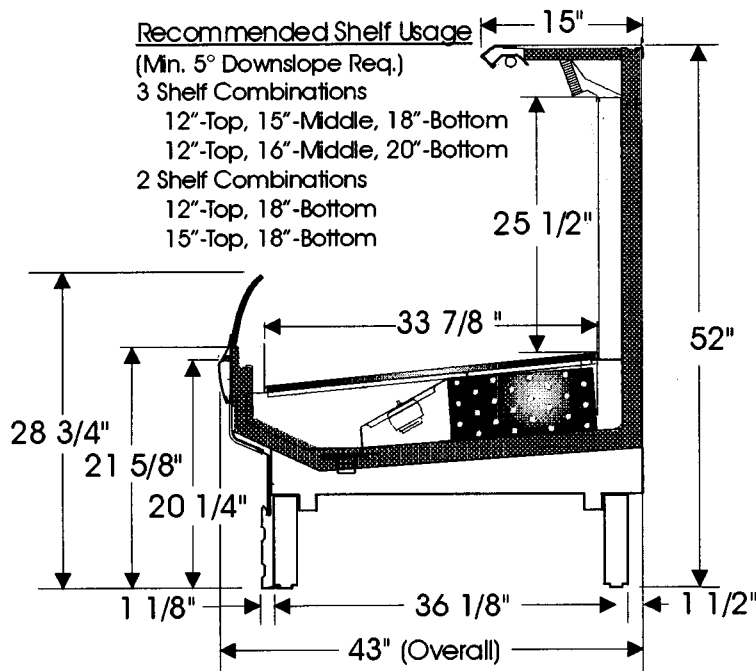

120 VOLT ELECTRICAL DATA (AMPS)			
LENGTH	STD. FANS	ECM FANS	ANTI-SWEATS
6'	1.0	.4	.07
8'	1.0	.4	.09
12'	1.5	.6	.14

STANDARD 120 VOLT T-8 LIGHTING (AMPS) / ELECTRONIC BALLASTS (CANOPY)			
ROW	6'	8'	12'
1	.42	.5	.7
OPTIONAL 120 VOLT T-8 LIGHTING (AMPS) / ELECTRONIC BALLASTS (SHELVES)			
ROWS	6'	8'	12'
1	.58	.6	.9
2	.84	1.1	1.6
3	1.1	1.4	2.1

**FLOOR PLAN**

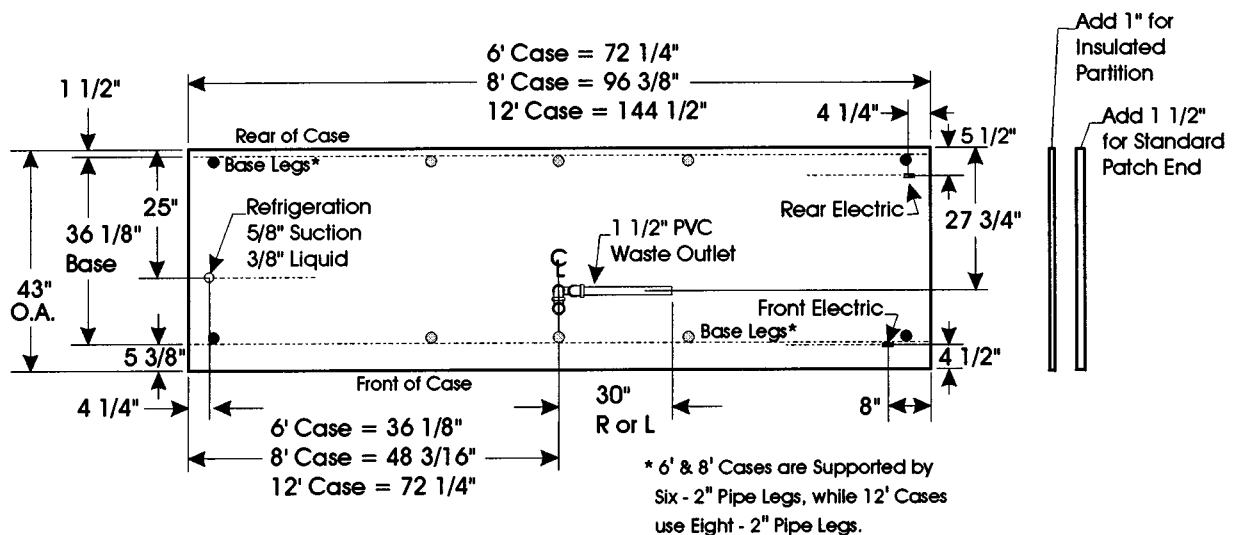

## INSTALLATION PROCEDURES

### Carpentry Procedures

#### Case Line-Up

**NOTE**

The NSSD cases are shipped on casters that are replaced with adjustable legs during case line-up and installation.

See the "General-UL/NSF I&S Manual" for the proper case line-up procedures.

#### Case Pull-Up Locations

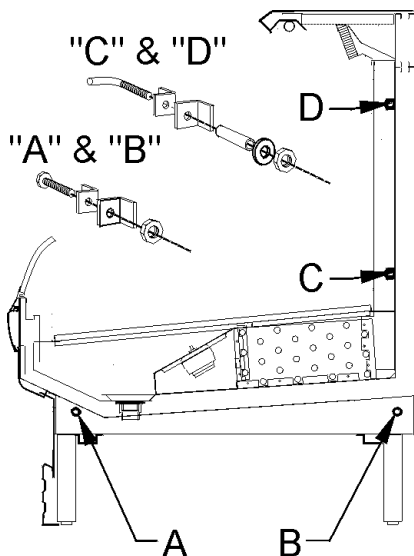

All NSSD models have four pull-ups at each end of the case. Pull-ups A, B, C and D are located as shown and should be installed and tightend starting with A and finishing with D.

See "General-UL/NSF I&S Manual" for line-up assembly instructions.

### Electrical Procedures

#### Electrical Considerations

**CAUTION**

Make sure all electrical connections at components and terminal blocks are tight. This prevents burning of electrical terminals and/or premature component failure.

**NOTE**

The NSSD has two raceway locations that can house the electrical wiring, components and terminal blocks. All components and wiring can be located in either the lower front or the lower rear of the case.

#### Case Fan Circuit

This circuit is to be supplied by an uninterrupted, protected 120V circuit. The case fan circuit is not cycled, except when equipped for gas defrost. On gas defrost cases the fan circuit is controlled by a 50/40 klixon.

**NOTE**

With gas defrost, the fans will not start until the coil temperature reaches 40°F at the fan delay thermostat.

#### Fluorescent Lamp Circuit

Case lighting is supplied by T-8 electronic ballast lights. It is controlled by a light switch in each case. The standard lighting is 1-row of T-8 canopy lights. NSSD models also offer up to 3 rows of optional T-8 shelf lights.

#### Anti-Sweat Heater Circuit

NSSD cases have three anti-sweat heaters. One in the top light assembly, one in the front glass trim rail and one in the front glass retain-er. All anti-sweat heaters are wired directly to the main power supply so they can operate at all times.

**Defrost Information**

See "General-UL/NSF I&S Manual" for operational descriptions for each type of defrost control.

**Defrost Control Chart**

Defrost Type	Defrosts Per Day	Defrost Duration (Min)	Term. Temp.
Off Time	6	28	----
Electric	6	36	50°F
Gas	6	12-15	55°F

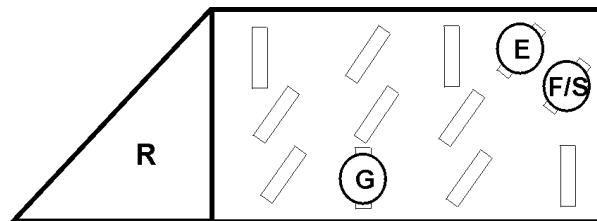

- E = Electric Defrost Termination
- G = Gas Defrost (Fan Delay)
- F/S = Electric Defrost Failsafe (Opt.)

**NOTE**

The termination klixon for gas defrost is located at the bypass check valve at the left end of the evaporator coil.

Most klixons are located on the right end of the evaporator coil. The diagram shows the location for each defrost type that uses a klixon.

**CAUTION**

If electronic sensors are used in place of the klixons, the sensors must be located in the same location as the klixons for that defrost type. Any other locations will effect the refrigeration efficiency of the case.

**WIRING DIAGRAMS**

**ELECTRICIAN NOTE - OVERCURRENT PROTECTION**

120V circuits should be protected by 15 or 20 Amp devices per the requirements noted on the cabinet nameplate or the National Electrical Code, Canadian Electrical Code - Part 1, Section 28. 208V defrost circuits employ No. 12 AWG field wire leads for field connections. On remote cases intended for end to end line-ups, bonding for ground may rely upon the pull-up bolts.

The following wiring diagrams on pages 8 thru 11 will cover the NSSD case circuits including all defrost and lighting wiring circuits.

# NSSD Domestic & Export (50Hz) Case Circuits (6', 8' & 12' Cases)

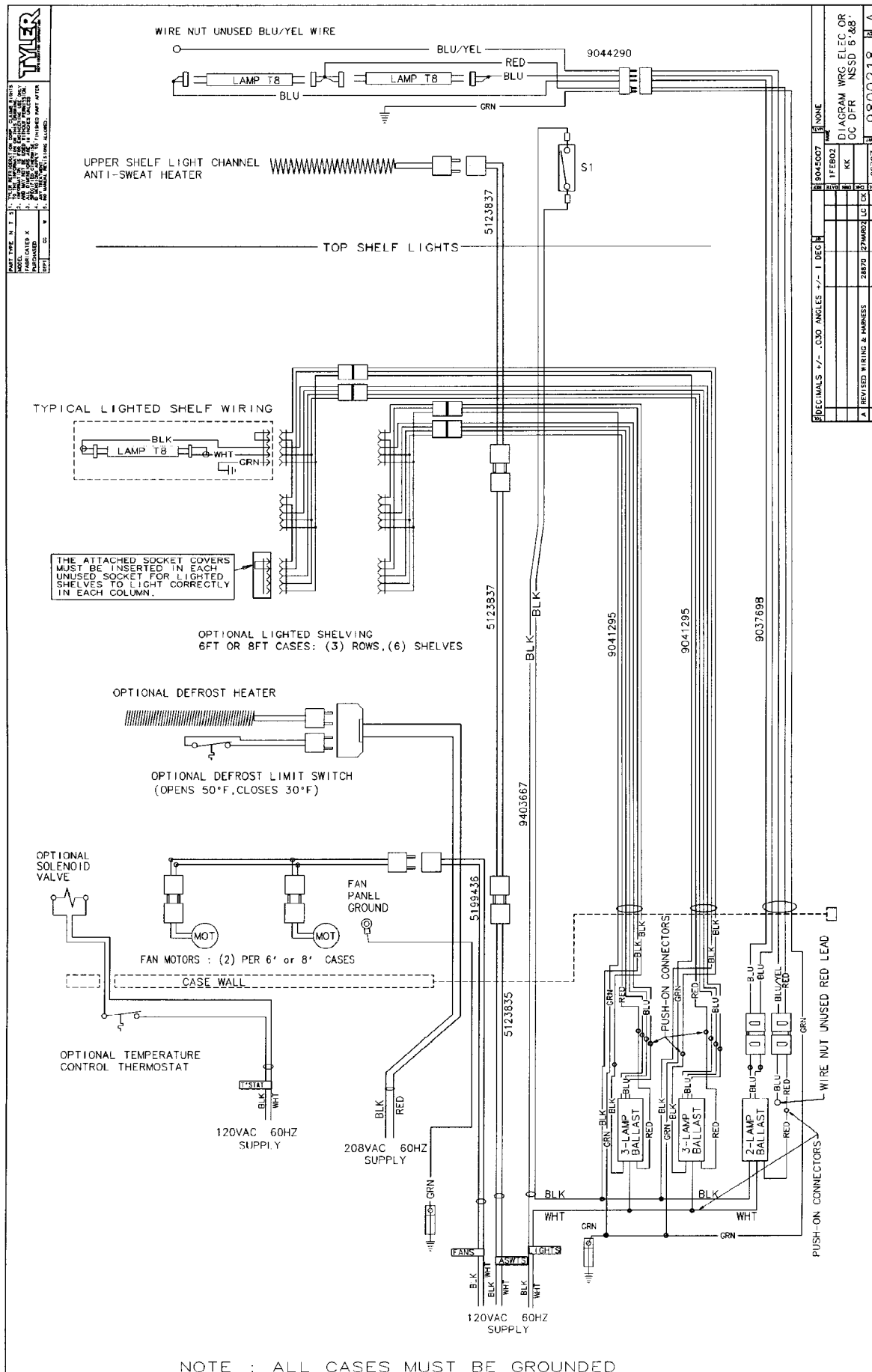



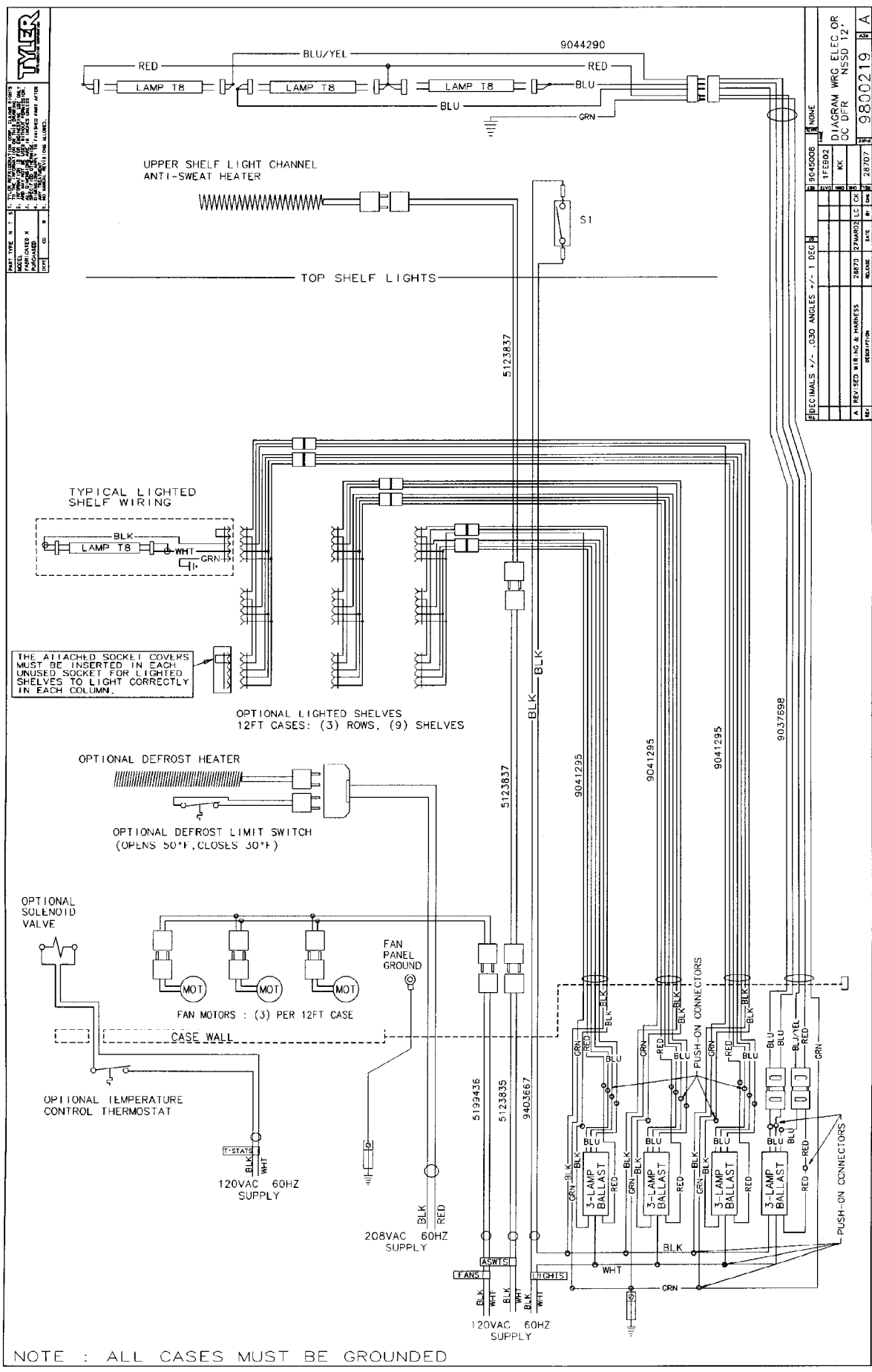

NOTE : ALL CASES MUST BE GROUNDED

**TYLER**

WIRE NUT UNUSED BLU/YEL LEAD  
 BLU/YEL  
 RED  
 9044290  
 LAMP T8  
 BLU  
 GRN  
 UPPER SHELF LIGHT CHANNEL  
 ANTI-SWEAT HEATER  
 TOP SHELF LIGHTS  
 S1  
 5123837

**TYPICAL LIGHTED SHELF WIRING**

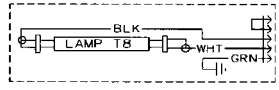

THE ATTACHED SOCKET COVERS MUST BE INSERTED IN EACH UNUSED SOCKET FOR LIGHTED SHELVES TO LIGHT CORRECTLY IN EACH COLUMN.

OPTIONAL LIGHTED SHELVES  
 6FT OR 8FT CASES: (3) ROWS, (6) SHELVES

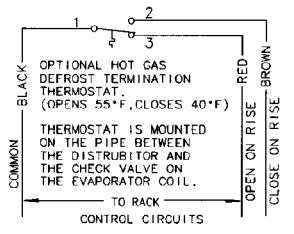

HOT GAS DEFOST FAN MOTOR DELAY THERMOSTAT  
 (OPENS 50°F, CLOSES 40°F)



FAN MOTORS: (2) PER 6' or 8' CASES  
 CASE WALL

OPTIONAL TEMPERATURE CONTROL THERMOSTAT

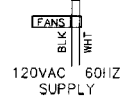

120VAC 60HZ SUPPLY

120VAC 60HZ SUPPLY

NOTE : ALL CASES MUST BE GROUNDED

REV	DATE	BY	CHK	APP	DESCRIPTION
1	28/10/72	JK	LC	CC	REVISED WIRING & PARTS
2	28/10/72	JK	LC	CC	REVISIONS +/- .030 ANGLES +/- 1 DEG
3					NONE
4					IFEB02
5					9044834

DIAGRAM WRG HG DFR  
 NSSD 5'88'  
 9800220 A

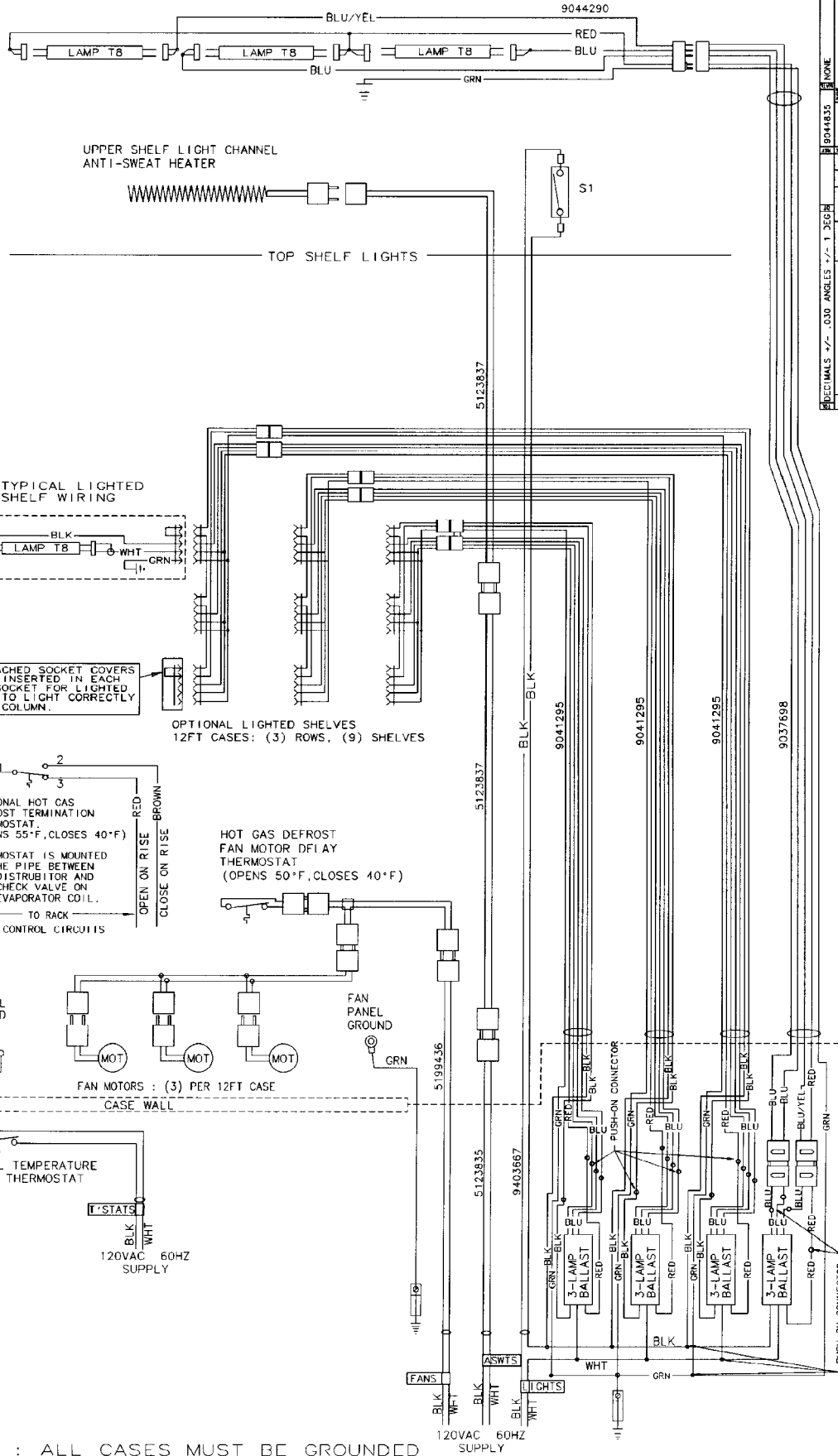

NOTE : ALL CASES MUST BE GROUND

90444835		NONE	
FEEDS			
REV	DATE	DESCRIPTION	
A	28/07	REVISED WIRING & PARTS	
B			
C			
D			
E			

DECIMALS +/- .030 ANGLES +/- 1 DEG

DIAGRAM WRG HG DFR NSSD 12

980021 A

## CLEANING AND SANITATION

### Component Removal and Installation Instructions for Cleaning

#### Shelves and Shelf Brackets

1. Remove product from shelves.
2. If shelf has a light, unplug the light cord from the socket in the rear duct panel. Completely insert socket cover in the light socket to protect the receptacle.
3. Push shelves back and then lift up and out to remove them from the shelf brackets.
4. Remove shelf brackets from slots in rear uprights.
5. After cleaning, replace in reverse order.

#### Bottom Trays

1. Remove product from bottom of case.
2. Grasp and lift out each of the bottom trays from the case interior.
3. After cleaning, replace in reverse order.

#### Front Air Ducts

1. Remove lower trays, see this page.
2. Lift out front air duct sections.
3. After cleaning, replace in reverse order.

#### Rear Duct Panels (w/o Shelf Light Sockets)

1. Remove shelves and bottom trays, see above.
2. Remove mounting screws and rear duct panels from case.
3. After cleaning, replace and secure rear duct panels in reverse order.

#### (with Shelf Light Sockets)

1. Remove shelves and bottom trays, see above.
2. Remove mounting screws from rear duct panel.

3. Slowly lift out rear duct panel until the shelf harness connector near the top of the panel can be accessed.
4. Disconnect shelf harness connector and complete removing the rear duct panel.

#### **WARNING**

**Rear duct panels with electrical receptacles can be cleaned without removing the electrical receptacles. Do not get moisture on electrical wires when cleaning under this cover. Moisture on wires could cause premature product failure and/or personal injury or death from electrical shock.**

5. After cleaning, reconnect the shelf harness connector and replace and secure rear duct panels in reverse order.

#### Discharge Air Honeycomb

1. Loosen screws securing rear retainer plate.

#### **NOTE**

**Note position of the honeycomb grid during removal so it can be reinstalled the same way.**

2. Slide rear retainer plate back until the honeycomb grid sections can be removed from the top duct.

#### **CAUTION**

**Improper installation of the honeycomb grid section could result in improper air flow and/or poor refrigeration.**

3. After cleaning, replace honeycomb grid sections as they were removed and secure with the rear retainer plate and screws.

#### Front Lower Cladding

1. Remove front kickplate.
2. Lift and pull out front lower cladding until rear tabs clear holes in front of frame assembly. After rear tabs are clear, pull down on cladding to clear upper tabs from slots in bottom of upper front cladding and remove cladding from case.

### Front Upper Cladding

1. Remove plexiglas from plexiglas retainer. Remove screws and plexiglas retainer from top of bumper retainer
1. Remove color band, bumper and bumper retainer from the case. (See General-UL/NSF I&S Manual.)
2. Remove front kickplate.
3. Remove screws and front lower cladding. See page 12.
4. Remove screws from top and bottom of upper cladding and remove front upper cladding.
5. After cleaning, replace front upper cladding and remaining front components in the reverse order.

## GENERAL INFORMATION

### NSF Product Thermometer Installation

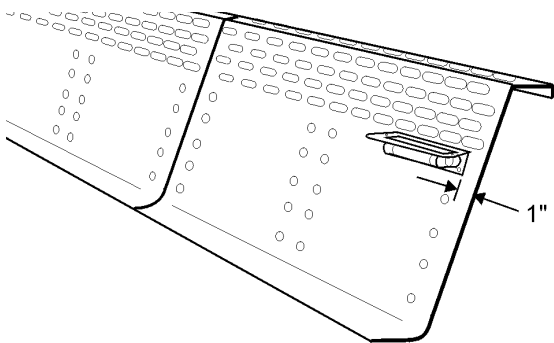
1. Unwrap the thermometer and bracket assembly shipped loose with the case.
  2. Remove left front return air duct.
- 
3. Position bracket 1" in from left edge and just under the bottom return air duct holes.
  4. Mount the bracket to the return air duct with two self-tapping screws.
  5. Replace the front return air duct.

### Radiant Heat Information

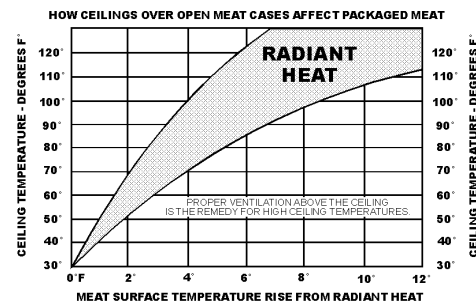
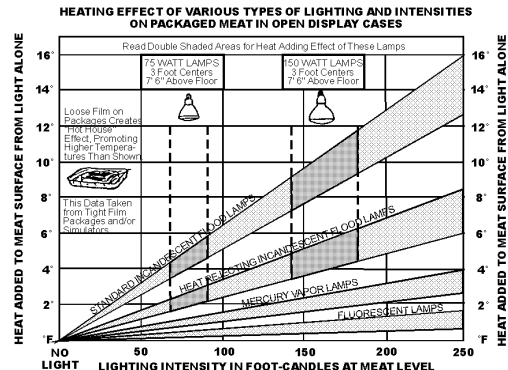

A wide temperature range is shown for each type of lighting. This data does not show all situations. Many situations will have higher package warm-up figures than indicated.

It is generally known that the temperature of displayed meat in refrigerated cases will run higher than the circulated air temperature of the cases. A dial thermometer stuck into the center of a piece of meat compared with one in the air stream quickly confirms this fact. Another fact is that the surface temperature of the meat will be higher than the center temperature due to radiant heat. TYLER's ongoing research identifies sources of radiant heat and accurately measures and records it. These charts were developed from the information gathered during this research. Two major sources of radiant heat are from display lights and ceiling surfaces. Additional heat sources come from bad display practices which either overload the case with product or allow voids in the product display. Poor display practices impair the efficiency of the refrigeration, adding to the surface temperature of the meat. Bacteria and molds grow when surface

temperatures rise above 45°F. This prematurely discolors displayed meats and causes unnecessary meat department losses.

**Radiant Heat Measurement**

Place two accurate dial thermometers side by side in a case. Cover one of the thermometer stems with black friction tape. The temperature difference is the approximate amount of radiant heat. A change in display lighting or a reduction of high ceiling temperatures (over 80°F) could reduce the radiant heat in the case.

**Display Practices**

Encourage butchers to maintain all meat below the case load lines and to eliminate product voids. Case screens could be covered in some instances to keep the refrigerated air over the display.

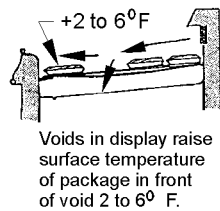

**CAUTION**

The quality damage done to meat products by high temperatures and/or contamination during delivery, cooler storage, cutting and wrapping cannot be repaired by placing the products into properly operating display cases.

**SERVICE INSTRUCTIONS**

**Light Servicing**

See "General-UL/NSF I&S Manual" for T-8 lamp, fan blade and motor, and color band and bumper replacement instructions.

**Ballast and Lighting Locations**

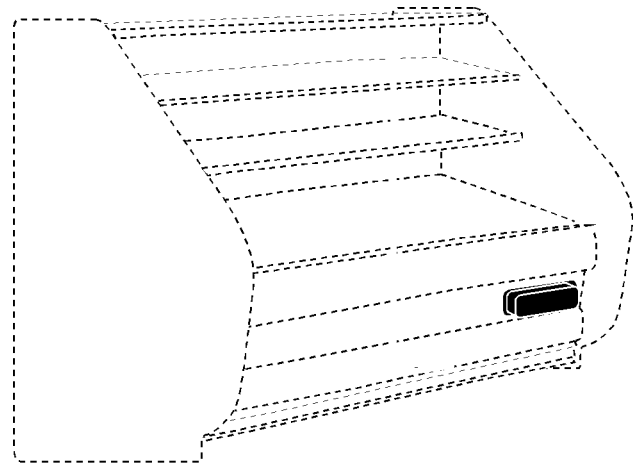

All NSSD light ballasts are located either in the front raceway behind the lower front cladding, or in the rear raceway behind the rear rail cover. This includes remote ballasts for optional shelf lights. The canopy light(s) are under the canopy light channel in the top of the case. The optional shelf lights are mounted in separate light fixtures under the front of each shelf section.

In order to retain safety approval with Underwriters Laboratory and the Canadian Standards Association, the mounting of electrical components and interconnecting wires must not deviate from the following instructions. Only qualified personnel are authorized to install the accessory items. TYLER Refrigeration recommends you order all component parts from its Service Parts Department.

Rear Ballast Location Replacement

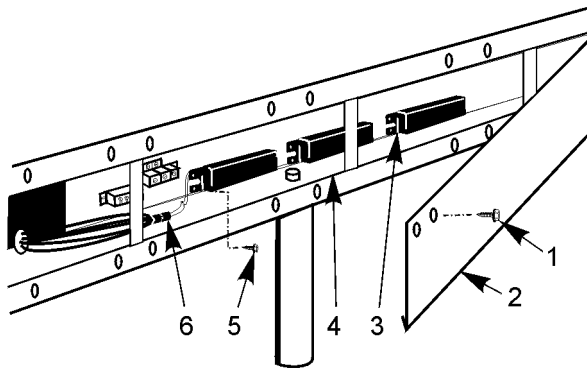

1. Remove screws (1) and rear rail cover (2) from rear of case.

**NOTE**

If tappit screws are not available, a star-washer should be used between the ballast and the heads of the screws.

2. Install required number of ballasts (3) in rear electrical raceway (4) with two screws (5) each.
3. Identify and connect required wiring harnesses (upper, lower, etc...) to the ballast connectors (6).
4. Replace rear rail cover (2) and secure with screws (1).

Defrost Heater Replacement

**WARNING**

Always shut off electricity to case before replacing a defrost heater. Automatic cycling of fans or electrical power to wire ends could cause personal injury and/or death.

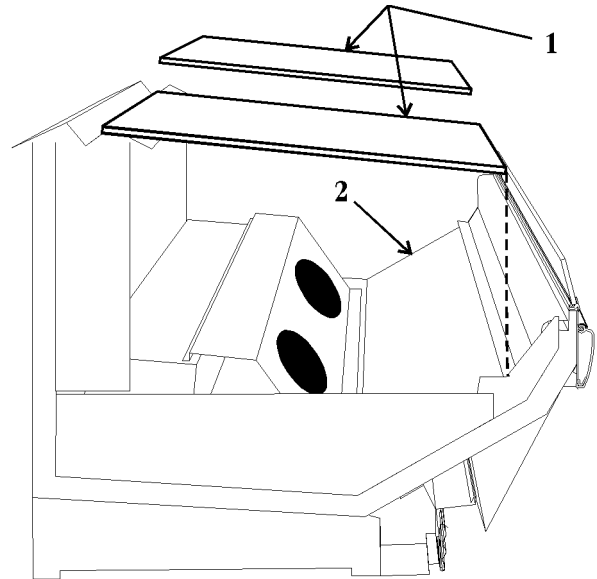

1. Remove bottom trays (1) from case (2).

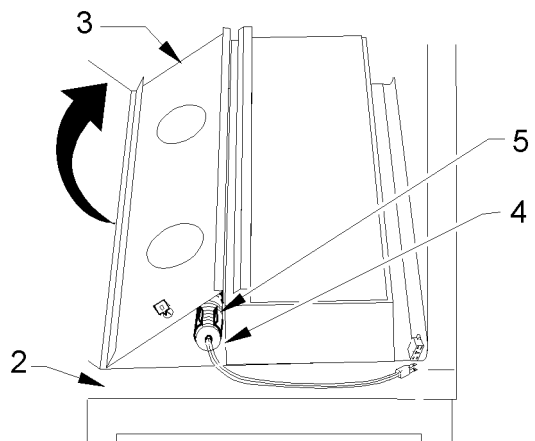

2. Unclip and lift up fan plenum (3).
3. Disconnect and remove defrost heater (4) from mounting clips (5) and case (2).
4. Install new defrost heater (4) in reverse order.
5. Restore electrical power to case.

### Anti-Sweat Replacement

#### WARNING

Shut off or disconnect power supply to case before changing an anti-sweat. Electrical power from wire ends could damage other components and/or cause personal injury or death.

#### Top Light Channel Anti-Sweat Replacement

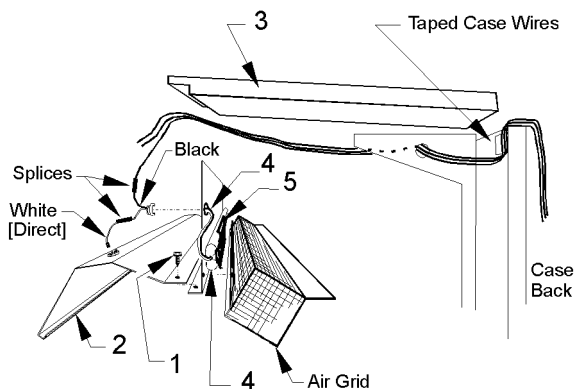

1. Remove screws (1) and lower the top light channel assembly (2) from top of the case (3).
2. Disconnect or cut the defective anti-sweat wires (4) from the case wires.
3. Remove and replace the aluminum tape (5) and defective anti-sweat wire (4) from the back of the top light channel assembly (2).
4. Position new anti-sweat wire (4) in case ) and secure with new aluminum tape (5).
5. Reconnect the new anti-sweat wires (4) to case wires and reinstall the top light channel assembly (2) with screws (1).
6. Restore electrical power to the case.

### Front Curved Plexiglas Replacement

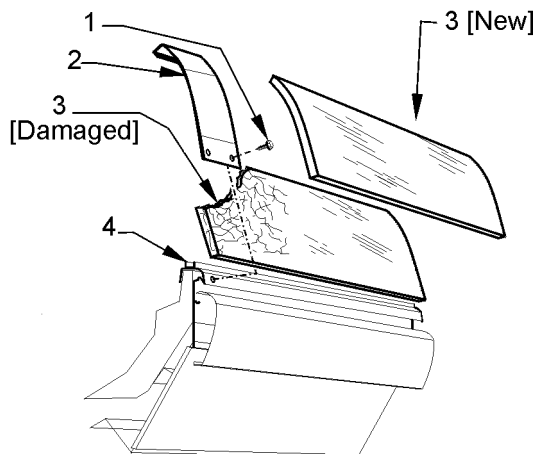

1. Remove two screw (1) and plexiglas joint trim (2) from both joints of the damaged plexiglas (3).
2. Remove damaged plexiglas (3) from plexiglas retainer (4).
3. Position new plexiglas (3) in plexiglas retainer (4).
4. Install plexiglas joint trim (2) with screw (1) over the joint areas of plexiglas (3).



## **PARTS INFORMATION**

### **Operational Parts List**

<b>Case Usage</b>	<b>Domestic</b>		
Electrical Circuit	115 Volt 60 Hertz		
Case Size	6'	8'	12'
Fan Motor	5243498 9 Watt	5243498 9 Watt	5243498 9 Watt
Fan Motor Brackets	5962268	5962268	5962268
Fan Bracket Plate	9041077	9041077	9041077
Fan Blades (7" 35° 5B)	9044934	9044934	9044934
Opt. ECM Fan Motor	9025002 8 Watt	9025002 8 Watt	9025002 8 Watt
Opt. ECM Fan Motor Brackets	9025005	9025005	9025005
Opt. ECM Fan Blades (7" 35° 5B)	9044934	9044934	9044934
T-8 Ballast (canopy & shelf) (canopy / 1-row)	5991029	5991029	5991030
(opt. shelf / 2-row or 3-row)	5991030	5991030	5991030
T-8 Lampholder (canopy or shelf)	9041897	9041897	9041897
Anti-Sweat Heater Wire (top light)	9043426	9043427	9043428
Opt. Elec. Def. Heater	5125153	5124521	5124522
Opt. Elec. Def. Limit Klixon	5125211	5125211	5125211
Opt. Gas Def. Fan Delay Klixon	9023503	9023503	9023503
Opt. Gas Def. Term. Klixon	9023508	9023508	9023508
NSF Product Thermometer	5967100	5967100	5967100

**For information on operational parts not listed above contact the TYLER Service Parts Department.**

**Cladding and Trim Parts Lists**

Item Description	NSSD		
	6'	8'	12'
1 Screw (per cover)	5100217 (2)	5100217 (2)	5100217 (2)
2 Joint Trim, Rear Riser	5932659	5932659	5932659
3 Plexiglas, Curved	9800193	9800194	9800193 (2)
RH Plexiglas Trim Assy.	9800225	9800225	9800225
LH Plexiglas Trim Assy.	9800226	9800226	9800226
CTR Plexiglas Trim Assy.	-----	-----	9800211
Plexiglas Retainer	9800203	9800204	9800203 (2)
4 Plexiglas Joint Trim	9800211	9800211	9800211
5 Screw	5100217 (2)	5100217 (2)	5100217 (2)
6 Bumper Retainer	-----	color per order	-----
7 Color Band, Ptd.	9023796	9023799	9023801
8 Color Band Backer, Ptd.	9040223	9040223	9040223
9 Bumper Backer	-----	color per order	-----
10 Bumper End Trim	-----	color per order	-----
11 Bumper	-----	color per order	-----
12 Upper Front Cladding, Ptd.	9800000	9800003	9800006
Screw	5183536 (8)	5183536 (10)	5183536 (12)
13 Upr. Frt. Cladding Joint Trim	9800021	9800021	9800021
Screw	9024814 (2)	9024814 (2)	9024814 (2)
14 Shoulder Screw, Bumper Ret.	9025833 (12)	9025833 (16)	9025833 (24)
15 Lwr. Frt. Cladding, Ptd.	9800212	9045243	9037941
16 Lwr. Frt. Cladding Joint Trim	9800024	9800024	9800024
Screw	9024814 (2)	9024814 (2)	9024814 (2)
17 Frt. Kickplate Assembly	9024937	9024938	9024939
18 Kickplate Joint Trim	9043816	9043816	9043816
Screw	5619204 (4)	5619204 (4)	5619204 (4)
19 Pipe Leg (2" X 7.25")	9045242 (6)	9045242 (6)	9045242 (8)
20 Horizontal End Trim	5964733	5964733	5964733
21 End Close-off, Ptd. (per patch end)	9037922	9037922	9037922
22 Opt. Rear Base Close-off	-----	9037907	9037908
23 Rear Rail Cover, Ptd.	9024929	9024928 (2)	9024929 (2)
Screw	9043080 (16)	9043080 (24)	9043080 (32)

