



-User's Manual

Section 1 to 7

-Maintenance Manual

Section 8

-Engine Manual

Annex

X-AIR

« HANUMAN »

X-AIR HANUMAN 602T AP (with Rotax 582 and parachute)

X-AIR HANUMAN 602T SP (with Rotax 582 without parachute)

X-AIR HANUMAN JABIRU AP (with Jabiru 2200 and parachute)

X-AIR HANUMAN JABIRU SP (with Jabiru 2200 without parachute)

X-AIR HANUMAN 912 AP (with Rotax 912 and parachute)

RAND-KAR sa Canal de la Martinière 44320 Frossay - France Tél. : +33 (0) 240 642 166 Fax : +33 (0) 240 641 522
Société au capital de 46 000 € siret : 384.220.695.00017 RM 44 APE 353 B FR 39.384.220.695
<http://www.randkar.fr> E-mail : contact@randkar.fr support technique xair-info@randkar.fr

SUMMARY

INTRODUCTION (Pages 5 to 9)

SECTION 1 : General points (Pages 11 to 15)

- 1-1 On-board documents
- 1-2 3 views drawings
- 1-3 Design features
 - 1-3.1 Dimensions
 - 1-3.2 Landing gear
 - 1-3.3 Travel of control surfaces
 - 1-3.4 Fuel tank
 - 1-3.5 Wings
 - 1-3.6 Fuselage
 - 1-3.7 Empennage
 - 1-3.8 Elevator
 - 1-3.9 Direction
 - 1-3.10 Seats
 - 1-3.11 Controls
 - 1-3.12 Diverse
- 1-4 Settings

SECTION 2 : Limitations (Pages 17 to 19)

- 2-1 Certification type
- 2-2 Pilot's competence
- 2-3 Use conditions
- 2-4 Load factor
- 2-5 Weight and balance
- 2-6 Limited speeds

SECTION 3 : Powerplant (Pages 21 to 23)

- 3-1 Jabiru 2200
 - 3-1.1 Manufacturer
 - 3-1.2 Technical datas
 - 3-1.3 Propeller
 - 3-1.4 Noise pollution
- 3-2 Rotax 582
 - 3-2.1 Manufacturer
 - 3-2.2 Technical datas
 - 3-2.3 Propeller
 - 3-2.4 Noise pollution
- 3-3 Rotax 912
 - 3-3.1 Manufacturer
 - 3-3.2 Technical datas
 - 3-3.3 Propeller
 - 3-3.4 Noise pollution

SECTION 4 : Performances (Pages 25 to 27)

4-1 X-AIR Hanuman Jabiru

- 4-1.1 Service ceiling
- 4-1.2 Take off distance
- 4-1.3 Climb
- 4-1.4 Speeds
- 4-1.5 Engine off
- 4-1.6 Landing

4-2 X-AIR Hanuman 602T (Rotax 582)

- 4-2.1 Service ceiling
- 4-2.2 Take off distance
- 4-2.3 Climb
- 4-2.4 Speeds
- 4-2.5 Engine off
- 4-2.6 Landing

4-3 X-AIR Hanuman 912

- 4-3.1 Service ceiling
- 4-3.2 Take off distance
- 4-3.3 Climb
- 4-3.4 Speeds
- 4-3.5 Engine off
- 4-3.6 Landing

SECTION 5 : Standard procedure (Pages 29 to 35)

5-1 Pre-flight inspection

- 5-1.1 Cockpit
- 5-1.2 Engine
- 5-1.3 Airframe

5-2 Installation on board and starting engine

- 5-2.1 Engine cold
- 5-2.2 Engine hot

5-3 Check before take-off

5-4 Take-off

5-5 Climb

5-6 Turns

5-7 Flight in turbulences

5-8 Stall

- 5-8.1 Engine off
- 5-8.2 Full throttle

5-9 Cruise

5-10 Descent, approach, landing

5-11 Crosswind

5-12 Engine stop

5-13 Parking

5-14 Performances

SECTION 6 : Emergency procedures (Pages 37 to 40)

- 6-1 Engine failure, emergency landing
 - 6-1.1 before take-off
 - 6-1.2 on take-off
 - 6-1.3 In flight
- 6-2 Fire
 - 6-2.1 Engine fire
 - 6-2.2 Cabin fire
 - 6-2.3 Electric cables fire
- 6-3 Regulator failure
- 6-4 Landing without elevator
- 6-5 Emergency landing with engine
- 6-6 Emergency landing on water
- 6-7 Emergency landing on trees
- 6-8 Flight in hard rain
- 6-9 Flight in icing conditions
- 6-10 spin
- 6-11 Use of parachute

SECTION 7 : Accessories and options (Pages 41 to 44)

- 7-1 using advices
 - 7-1.1 Skis
 - 7-1.2 Floats
 - 7-1.3 Banner
 - 7-1.4 Crop spraying
- 7-2 Repercussion of options mounting
 - 7-2.1 Skis
 - 7-2.2 Floats
 - 7-2.3 Banner
 - 7-2.4 Crop spraying
 - 7-2.5 Balistic parachute

SECTION 8 : Maintenance (Pages 45 to 55)

- 8-1 Taking down and transport
- 8-2 Airframe maintenance
- 8-3 Propeller
- 8-4 Powerplant maintenance
 - 8-4.1 Jabiru 2200
 - 8-4.2 Rotax 912
 - 8-4.3 Rotax 582

ANNEX : Engine manufacturer's manual

INTRODUCTION

Dear fellow pilot,

Our congratulations and our thanks, for choosing our new **X-AIR Hanuman** Ultralight. We wish you many pleasant hours of flight.

This maintenance and flight manual will help you achieve safe flying conditions.

Please read it attentively and follow all the instructions concerning assembly, preflight inspection, in-flight operation and maintenance.

Feel free to contact your dealer for any additional information about your ultralight, and for any remark you wish to make to improve the quality of this document, the service we can offer, or the general safety of your flights.

This ultralight is an aircraft, and as such must be flight-tested by a certified instructor. All test flights to be conducted in still air.

Never forget that you alone are responsible for the safe handling of your **X-AIR Hanuman**

Constant vigilance and attentiveness are essential.

Your own safety, the safety of your passenger and other fliers, as well as the future of ultralight flying are at stake.

Many happy flights!

WARNING

Even in the best of conditions, ultralight flying may be hazardous. The user of this ultralight acknowledges the existence of such hazards.

Before his first flight, the user must pledge to read this manual. He shall follow exactly the instructions given.

He should be advised that the weight of any additional equipment increases the empty weight of the aircraft and decreases its useful load accordingly -- since maximum weight cannot be exceeded.

The user pledges to carry out all the mandatory alterations specified in Rand Kar's regular newsletters.

Any alterations or repair other than those specified by the manufacturer, or carried out without the manufacturer's agreement shall void the warranty.

The user must be a 3 axis licensed Ultralight pilot.

Rand Kar Sarl cannot be held responsible for any incidents or accidents caused by improper assembly, or reckless use of the ultralight, particularly when flying in bad weather, performing aerobatics maneuvers, or maneuvers exceeding the flight envelope of the aircraft.

at, Date

Signed

Name and adress :
.....
.....

Aircraft type :

Serial N°:
Engine :
EngineN° :
Gearbox :Gearbox ratio :
Propeller :
Instruments :
Other equipments :

**TO MAKE WARRANTY EFFICIENT, THIS FORM HAVE TO BE RETURNED TO
RAND KAR sa Canal de la Martinière
F - 44320 FROSSAY - FRANCE**

WARNING

Even in the best of conditions, ultralight flying may be hazardous. The user of this ultralight acknowledges the existence of such hazards.

Before his first flight, the user must pledge to read this manual. He shall follow exactly the instructions given.

He should be advised that the weight of any additional equipment increases the empty weight of the aircraft and decreases its useful load accordingly -- since maximum weight cannot be exceeded.

The user pledges to carry out all the mandatory alterations specified in Rand Kar's regular newsletters.

Any alterations or repair other than those specified by the manufacturer, or carried out without the manufacturer's agreement shall void the warranty.

The user must be a licensed Ultralight pilot.

Rand Kar Sarl cannot be held responsible for any incidents or accidents caused by improper assembly, or reckless use of the ultralight, particularly when flying in bad weather, performing aerobatics maneuvers, or maneuvers exceeding the flight envelope of the aircraft;

at, Date

Signed

Name and adress :
.....
.....

Aircraft type :

Serial N°:
Engine :
EngineN° :
Gearbox :Gearbox ratio :
Propeller :
Instruments :
Other equipments :

This form to be filled and returned to:
**RAND KAR sa Canal de la Martinière
F - 44320 FROSSAY - FRANCE**

Form to be filled and returned to after weighing operation of empty finished aircraft:

C.of G calculation method.:

Aircraft must be horizontal

Weighing operation must be done with 3 similar weighing machines located each under every wheel of the aircraft.

acceptable limit of C G = from 22 to 38,5 (cm)

		Weight (kg)
Front wheel	A	
Main gear : left wheel	B	
Main gear : right wheel	C	
TOTAL		

$$CG = \frac{150 \times A}{(A+B+C)} = \dots\dots\dots$$

Date:

Place:

Type of aircraft :

Serial Number

Identification sheet:

Max. empty weight :

Owner :

Signature :

**Form to be filled and returned to after weighing operation of empty finished aircraft to : RAND KAR sa Canal de la Martinière
F - 44320 FROSSAY - FRANCE**

Property sheet

Owner N°1

Name and address :
.....
.....

Observations.....
.....
.....

Owner N°2

Name and address :
.....
.....

Observations.....
.....
.....

Buying date

Owner N°3

Name and address :
.....
.....

Observations.....
.....
.....

Buying date

Owner N°4

Name and address :
.....
.....

Observations.....
.....
.....

Buying date

Owner N°5

Name and address :
.....
.....

Observations.....
.....
.....

Buying date

SECTION 1 : General points

1-1 Board documents

- The pilot will check before each flight the presence on board of all the necessary documentation according the local regulations.

1-2 3 views drawings

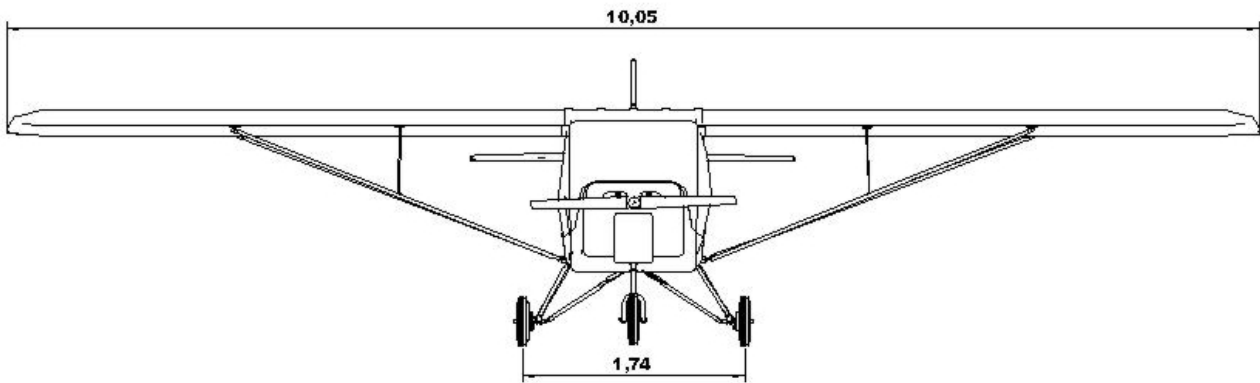

Front view / Vue de Face

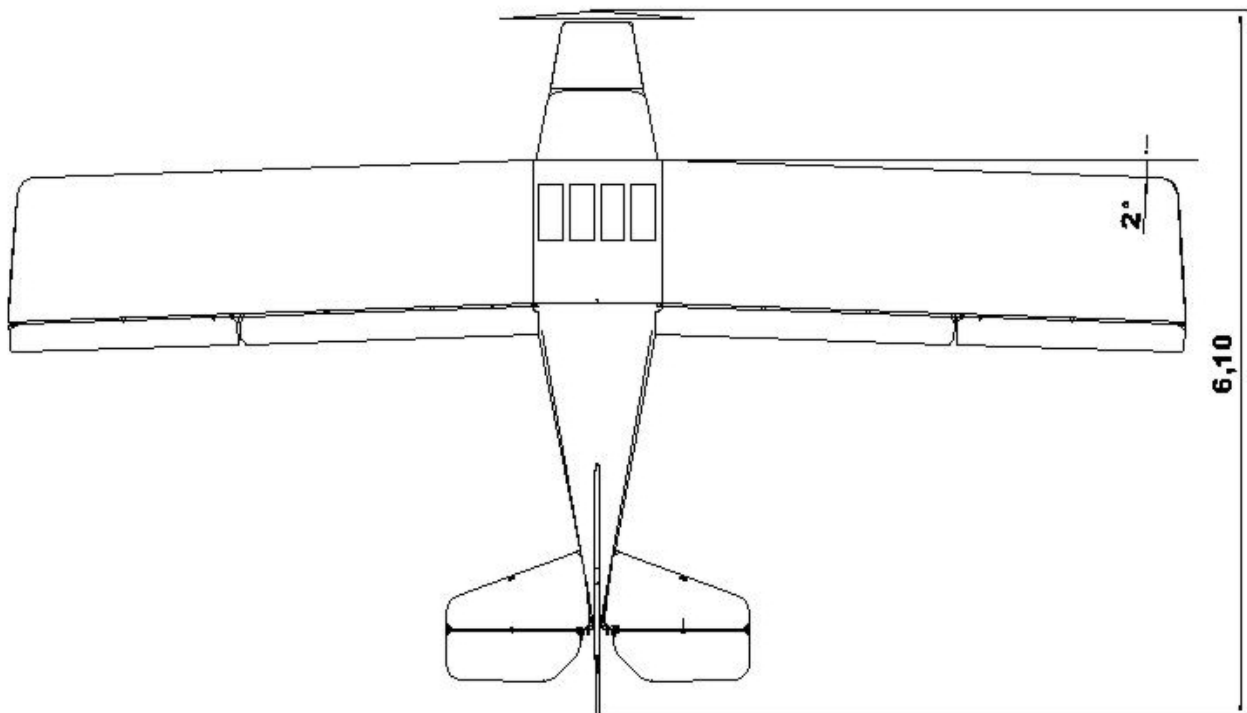

Top view / Vue de dessus

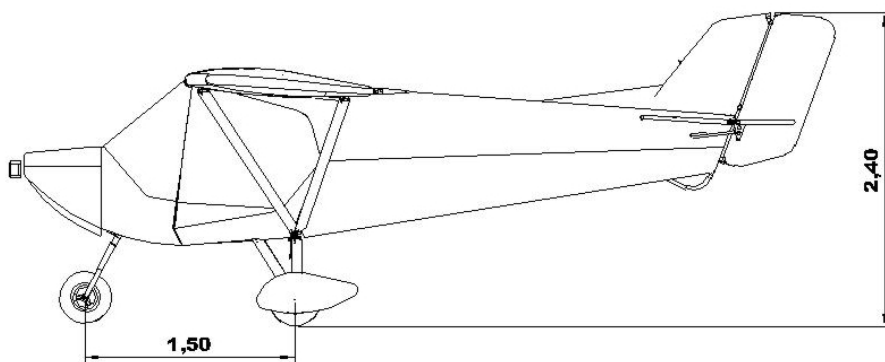

Side view / Vue de coté

1-3 Design features

1-3.1 dimensions :

Wing span	10.05 m
Length	6.09 m
Height	2.30 m
Surface	13.92 m ²

1-3.2 Landing gear

Tricycle, brakes on main gear.
 Wheel track width: 1.74 m
 Wheel base : 1.50 m
 Shock absorbers : Bungee
 Alloyed aluminium wheels
 Tyres 4 plys 3.50 x 8

1-3.3 Travel of control surfaces

Elevator : +30° -30°
 Ailerons : +43 -20°
 Rudder : +/-35°
 Elevator trim : +/-35°
 Flaps: 10°-20°-35°

1-3.4 Fuel tank

Behind the seats, capacity : 83 l
 Usual capacity : 80 l

1-3.5 Wings

profile NACA 23012
 Wings set at : 4° at root
 Twist : 2°
 Dihedral : 2°
 Sweep angle 2°

Wing material

Leading edge aluminium Tube 64,4x2 mm (Sleeved with 60 x 1,6)
 Trailing edge aluminium Tube 50 x 2 mm (Sleeved with 45,3 x 1.5)
 Compression tubes aluminium Tube 38 x 1,6 mm
 Tension cables 3 mm galva
 Wing tip tube aluminium Tube 25,4 x 1,6 mm
 Wing struts streamlined aluminium Rajhamsa 73 x 28 mm
 Battens 20 per wing diam.12,7 x 1,2 mm
 Fabric Dacron polyester 170 gr / m²

Ailerons material

Leading edge aluminium Tube 38 x 1,6 mm
 Trailing edge aluminium Tube 12.7 x 1,2 mm

Flaps material

Leading edge aluminium Tube 38 x 1,6 mm
 Trailing edge aluminium Tube 12,7 x 1,2 mm

1-3.6 Fuselage

cone rectangular section

Material

Main upper and lower tubes	aluminium Tube 28,6 x 2 mm
Stiffeners	aluminium Tube 18,6 x 1,1 mm
	aluminium Tube 12,7 x 1,2 mm

1-3.7 Empennage

Flat profile

MaterialFabric :Dacron polyester 170 gr / m²

Horizontal empennage :	Leading edge	aluminium Tube 25,4 x1,6 mm
	Trailing edge	aluminium Tube 25,4 x1,6 mm
Vertical empennage :	Leading edge	aluminium Tube 25,4 x1,6 mm
	Trailing edge	aluminium Tube 25,4 x1,6 mm

1-3.8 Elevator

Flat profile

MaterialFabric :Dacron polyester 170 gr / m²

Leading edge	aluminium Tube 25,4 x1,6 mm
Trailing edge	aluminium Tube 25,4 x1,6 mm

1-3.9 Rudder

Flat profile

MaterialFabric :Dacron polyester 170 gr / m²

Leading edge	aluminium Tube 25,4 x1,6 mm
Trailing edge	aluminium Tube 25,4 x1,6 mm

1-3.10 Seats

Composite with foam

1-3.11 Controls

Type 3 axis

Rudder: action on rudder pedals linked to front wheel with rod end and to rudder with cables

Handle stick	Double between legs
Manette de gaz	Double / left hand
Elevator control	push pull tube
Aileron control	3 mm cables + push-pull tubes
Flaps control	push-pull tubes

1-3.12 Diverse

Bolts: high quality 8.8 bichromated

3 mm stainless plates

powder coated painting

1-4 : Settings

The following elements can be subject to adjustment.

Elevator

To adjust the position of the stick relative to the pilot, the elevator control tube has three holes drilled to allow length adjustment .

Choose the suitable hole and insert the bolt.

Add loctite.

Tighten nut to close fit.

Ailerons

Tuning is achieved by turning the turnbuckles supplied and adjust rod ends.

This will alter the position of the ailerons, which are normally lined up with the wing lower surface.

If the ailerons have a strong inverse slope (trailing edge higher), the aircraft will tend to nose up.

If the slope is smaller (trailing edge lower), the aircraft will tend to nose down.

Flaps

Lined up with the wing lower surface.

SECTION 2 : Limitations

2-1 Certification

X-AIR Hanuman comes under Class 3 of the Ultralight Aircraft Certification of November, the 1st, 1998, regulating flight authorization of Ultralights.

Certificates stipulated in sections R133-1 and following of the Code de L'Aviation Civile are not required for ultralights, which are therefore exempted of any certification.

Each ultralight pilot must realize that he, and only he is responsible for the safe operation and maintenance of his aircraft.

The **X-AIR Hanuman** can be used under such varied and diverse conditions that it is impossible to give strict and all-inclusive instructions for its maintenance.

However, our present experience of the aircraft makes it possible to offer a realistic maintenance program.

When in doubt, the owner should always seek advice from a competent professional.

Needless to say, we at RANDKAR welcome all your remarks; we will be pleased to answer all your questions.

2-2 Required pilot competency

Student pilot license and orientation flight

Three-axis ultralight pilot license and further necessary training, as needed (an orientation flight is mandatory in any case).

2-3 : Flight conditions

Day VFR, no icing conditions

2-4 Load factor

Max loads on controls

Rudder	1380 Newton
Elevator	480 Newton
Ailerons	1300 Newton
Flaps	960 Newton

On airframe

Limit :	+ 4 G (+6 ultimate)
	- 2 G (-3 ultimate)

Warning : Load factor changes when turn					
bank:	15°	30°	45°	60°	70°
load factor	1,04	1,15	1,41	2	3

2-5 Weight and balance

2-5.1 Empty weight

	Basic empty weight (kg)	Max. empty weight (kg)
X-air Hanuman Jabiru SP	276	284
X-air Hanuman Jabiru AP	289	306,5
X-air Hanuman 602T SP	263	281
X-air Hanuman 602T AP	276	303,5
X-air Hanuman 912 AP	296	306,5

2-5.2 Maximum weight at take-off

Like any aircraft, an ultralight has a maximum take off weight. This must never be exceeded.

Maximum take off weights:

450 kg for the versions without parachute

472,5 kg for the versions with parachute

The builder will in no circumstances be held liable should these weight limitations be exceeded whatever the origin or nature of the additional or accessory equipment carried on the aircraft.

This manual includes all the information required for the use and maintenance of the aircraft.

This manual is specific to the aircraft it describes, and must be read by all users, as stated in Parts 1 and 2 of June 17, 1986 ruling.

2-5.3 Balance

Calculation method of C. of G.:

Aircraft must be horizontal

Weighing operation must be made with three similar weighing machine located each under each wheel of the plane

acceptable limit of C G = between 222 to 385mm forward from reference point

Reference point : axel of the base tube

		Weight (kg)
Front wheel	A	
Main gear : left wheel	B	
Main gear : right wheel	C	

$$CG = \frac{150 \times A}{(A+B+C)} = \dots\dots\dots$$

2-5.4 Changes made to the aircraft

Each owner is required to inform his local authority of any changes made to the aircraft's characteristics as recorded in its type certificate (engine, propeller or any other part) according to the local regulations

Added weight for options

OPTIONS	Weight Kg	lbs
Basic twin float set with fastenings and rudder	45	99,2
Amphibious twin float set with retract gear and fastenings	54	119
Hull with retract gear and sponsons	66	145,5
Snow skis with fastenings	9	19,84
Ballistic parachute with fastenings	12	26,45
Complete agri-spray set with fastenings	37	81,57
Microspray for agri-spraying	18	39,68

Total empty weight of X-AIR Hanuman is the sum of :

- Aircraft empty weight
- Weight of equipment (instruments, intercom, radio ...)
- Weight of options

To obtain total loaded weight, you must add :

- Weight of crew (pilot and passenger)
- Weight of fuel (0,72 kg, (1,59 lbs.) / liter)
- Weight of baggages

Total loaded weight must be less than, or equal to 450 kg (992 lbs.)

2-6 Limited speeds

-Maximum speed with flaps position 1	120 Km/h
position 2	110 Km/h
position 3	90 Km/h
- maximum crosswind speed	25 Km/h

SECTION 3 : Powerplant

3-1 Jabiru 2200

3-1.1 Manufacturer

Jabiru Aircraft Pty. Ltd.
P.O. Box 5168
BUNDABERG WEST QLD 4670
AUSTRALIA

3-1.2 Technical datas

4 cylinders, 4 stroke
2209 CC
80 hp (58KW) at 3300tr/mn
Double ignition
Air cooled
Direct drive
63 kg
Service life 1000 hours
Fuel : Unleaded 95 octane minimum or AVGAS 100 LL
Oil : automobile (follow engine manufacturer's instructions)

3-1.3 Propeller

-Two blades DUC « SWIRL »
Material : composite, diameter : 1620mm
-Two blades ARPLAST « Ecoprop »
Material : composite, diameter : 1630mm
-Two blades ULX
Material : wood, diameter 1540mm

3-1.4 Noise pollution

The most unfavourable case is a noise heard under trajectory when aircraft has just taken off, full throttle, optimum climb speed.

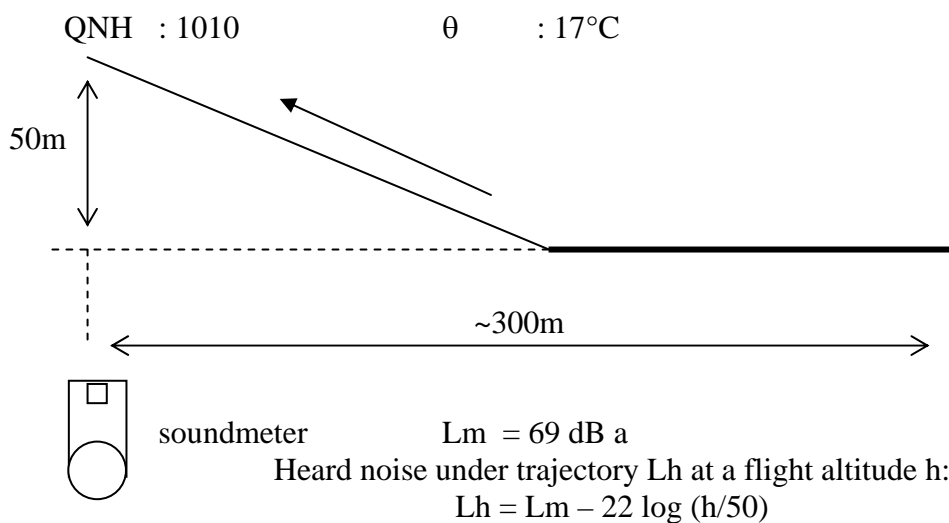

Example: heard noise by an observer located at 100m under the plane trajectory:

$$L_h = 69 - 22 \log(100/50) = 62.37 \text{ dB a}$$

3-2 Rotax 582

3-2.1 Manufacturer

Rotax Gesmbh & Co KG
Motorenfabrik, Welser STR 32
4623 Guunskirchen / Austria

3-2.2 Technical datas

2 cylinders 2 stroke
Water cooled
580,7 cc
Gearbox B :1/2,58
Gearbox C :1/3,47
Double ignition
Fuel : Mixture unleaded 95 octane + 2 stroke engine oil
Lubrication by mixture or separate oil.
%mixture following engine manufacturer's instructions
Oil : 2 stroke engine oil following engine manufacturer's instructions

3-2.3 Propeller

-Two blades ARPLAST « Ecoprop »
Material : composite, diameter : 1620mm
-Three blades ARPLAST « Ecoprop »
Material : composite, diameter : 1620mm
-Three blades DUC
Material : composite, diameter : 1620mm
-Two blades ULX
Material : wood

3-2.4 Noise pollution

The most unfavourable case is a noise heard under trajectory when aircraft has just taken off, full throttle, optimum climb speed.

QNH : 1010 θ : 17°C

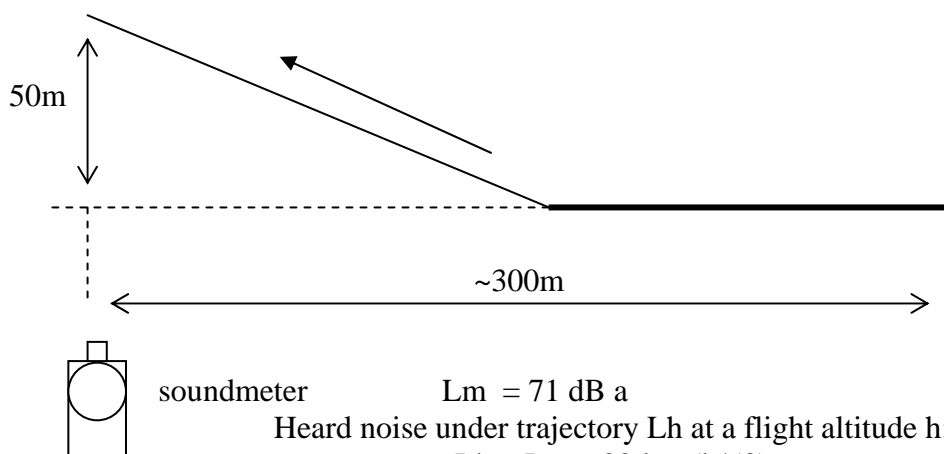

Example: heard noise by an observer located at 100m under the plane trajectory:

$$L_h = 69 - 22 \log(100/50) = 64.38 \text{ dB a}$$

3-3 Rotax 912

3-3.1 Manufacturer

Rotax Gesmbh & Co KG
Motorenfabrik, Welser STR 32
4623 Guunskirchen / Austria

3-3.2 Technical datas

4 cylinders 4 stroke
Air/Water/oil cooled
1211 cc
79 hp (58 KW) at 5800 tr/mn
Gearbox 1 :2,273
Double ignition
Fuel : Mixture unleaded 95 octane
Oil : 4 stroke engine oil following engine manufacturer's instructions

3-3 Propeller

-Two blades ARPLAST « Ecoprop »
Material : composite, diameter : 1620mm
-Three blades ARPLAST « Ecoprop »
Material : composite, diameter : 1620mm
-Three blades DUC
Material : composite, diameter : 1620mm
-Two blades ULX
Material : wood

3-3.4 Noise pollution

The most unfavourable case is a noise heard under trajectory when aircraft has just taken off, full throttle, optimum climb speed.

QNH : 1010 θ : 17°C

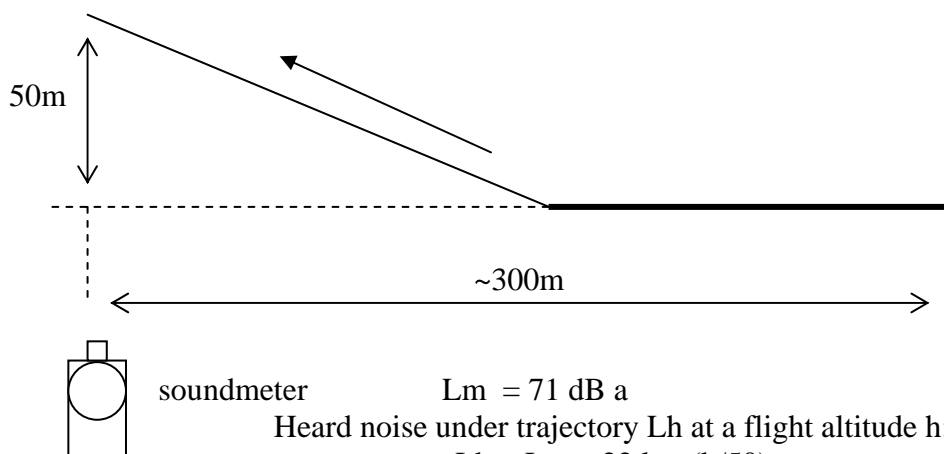

Example: heard noise by an observer located at 100m under the plane trajectory:

$$L_h = 69 - 22 \log(100/50) = 64.38 \text{ dB a}$$

SECTION 4 : Performances**4-1 X-AIR Hanuman Jabiru****4-1.1 Service ceiling**

4500 m (14700 ft)
(take care of oxygen lack)

4-1.2 Take-off distance

With flaps position 2

-Run : 80 m
-DF15 : 190 m

4-1.3 Climb

-Best ratio : 4,2 m/s at 95 Km/h (flaps position1)
-Best climb : 16 % at 95 Km/h (flaps position1)
-Normal climb : 3,5 m/s at 90 Km/h

4-1.4 Speeds

VD 220 Km/h
VNE 195 Km/h
VNO 175 Km/h
VC 140 Km/h at 3000 Rpm
VC eco 110 Km/h at 2500 Rpm
VA 85 Km/h
VS 72 Km/h no flaps
77 Km/h flaps position1
70 Km/h flaps position2
63 Km/h flaps position3

4-1.5 Engine off

-Maxi fineness : 11 at 100 Km/h (flaps position1)
-full flaps fineness 6,5 at 75 Km/h
-Best glide ratio 2.5 m/sat 100 Km/h (flaps position1)

4-1.6 Landing

Roll : 70 m
DA15 : 180 m

4-2 X-AIR Hanuman 602T (Rotax 582)**4-2.1 Service ceiling**

4500 m (14700 ft) (take care of oxygen lack)

4-2.2 Take off distance

with flaps position 2

-Run : 80 m
-DF15 : 190 m

4-2.3 Climb

-Best ratio : 3,5 m/sat 90 Km/h (flaps position1)
-Best climb : 14% at 90 Km/h (flaps position1)
-Normal climb : 3 m/s at 85 Km/h

4-2.4 Speeds

VD	210 Km/h
VNE	187 Km/h
VNO	170 Km/h
VC	130 Km/h at 6200 Rpm
VC eco	110 Km/h at 5500 Rpm
VA	85 Km/h
VS	72 Km/h (no flaps)
	77 Km/h (flaps position1)
	70 Km/h (flaps position2)
	63 Km/h (flaps position3)

4-2.5 Engine off

-Max fineness:	11	at	100 Km/h (flaps position1)
-Full flaps fineness:	6,5	at	75 Km/h
-Best glide ratio :	2.5 m/s	at	100 Km/h (flaps position1)

4-2.6 Landing

Roll :	70 m
DA15 :	180 m

4-3 X-AIR Hanuman 912**4-3.1 Service ceiling**

4500 m (14700 ft)
(take care of oxygen lack)

4-3.2 Take-off distance

With flaps position 2
-Run : 80 m
-DF15 : 190 m

4-3.3 Climb

-Best ratio :	4,2 m/s	at	95 Km/h (flaps position1)
-Best climb :	16 %	at	95 Km/h (flaps position1)
-Normal climb :	3,5 m/s	at	90 Km/h

4-3.4 Speeds

VD	220 Km/h
VNE	195 Km/h
VNO	175 Km/h
VC	140 Km/h at 5200 Rpm
VC eco	120 Km/h at 4800 Rpm
VA	85 Km/h
VS	72 Km/h no flaps
	77 Km/h flaps position1
	70 Km/h flaps position2
	63 Km/h flaps position3

4-3.5 Engine off

-Maxi fineness :	11	at	100 Km/h (flaps position1)
-full flaps fineness	6,5	at	75 Km/h
-Best glide ratio	2.5 m/sat		100 Km/h (flaps position1)

4-3.6 Landing

Roll :	70 m
DA15 :	170 m

SECTION 5 : Standard procedures

5-1 pre-flight inspection

This is where a safe flight begins.

A preflight inspection should be carried out before every take off.

5-1.1 Cabin

- Ignition switches off
- harness opened
- Seats fitted, cushions in place
- Free movement of controls
- Throttle off
- level in fuel tank checked, fuel cap torqued

5-1.2 Engine

Stand facing the engine and check:

- condition of propeller and propeller bolts and nuts
- reduction drive (no leakage, or excessive play in gears)
- engine hold down bolts (check that rubber mounts are seated flat against the base plate)
- coolant circuit (for water-cooled engine) and level of coolant liquid
- proper operation of blower and condition of blower belt (for air-cooled engine)
- condition of coil support plate
- condition of spark-plug caps
- condition of fuel line
- water- and/or oil-radiator retaining bolts, intake muffler rubber mounts (optional)
- exhaust muffler hold down, condition of rubber mount and muffler holding strap
- the exhaust system for apparent or incipient cracks

5-1.3 Airframe

Starting from the left, facing the aircraft, check:

- fastenings of leading edge tube
- the wheel fastenings and the tyre pressure
- the upper and lower wing strut fastenings
- Jury struts fastening
- along the length of the wing struts
- the condition of the wing leading edge
- fastenings of compression tubes and drag cables inside the wing sail
- check safe and firm positioning of wing tip fairing

Walk around to the trailing edge and check:

- upper and lower rear strut fitting
- compression tube and drag cables fittings
- trailing edge fastening
- Aileron and aileron controls fastenings
- Flaps and flaps controls fastenings

Walk back along the fuselage and check:

- linkage on elevator bellcrank
- fastenings of stab fitting cables
- clevises on pushtubes to elevator bellcranks
- elevator attach fittings
- hinges of elevator and rudder
- condition of fabric on tail surfaces
- shackles on rudder cables
- fastenings of rear fuselage section

Walk over to the right side and check:

- elevator hinge on right side
- Stab cables fastenings
- general condition of tail surfaces

Move forward and check:

- rudder cables are crossed
- fuselage tubes fittings
- the wheel fastenings and the tyre pressure

Move along trailing edge and check:

- trailing edge fastening
- upper and lower rear strut fitting
- aileron fittings and aileron controls
- flaps fittings and flaps controls
- compression tubes and drag cables fittings
- Trailing edge fittings and fabric along
- check safe and firm positioning of wing tip fairing

Move to the cabin along leading edge

- fastenings of leading edge tube
- the wheel fastenings and the tyre pressure
- the upper and lower wing strut fastenings
- Jury struts fastening
- along the length of the wing struts
- the condition of the wing leading edge
- fastenings of compression tubes and drag cables inside the wing sail

In the cockpit, check:

- proper condition of seat bolts
- shackle safetied
- condition and tension of aileron cables and linkages
- rudder cables (must cross)
- tank vents open and tanks properly attached
- Fittings and conditions of all cabin tubes
- throttle cable at throttle lever and normal operation of throttle
- choke, gas filter, gas line, and electric pump if fitted
- airspeed indicator operation, AGL or MSL setting on altimeter
- fuel level
- well work of flaps, ailerons, rudder and elevator controls

5-2 Installation on board and starting engine

When sit in the cockpit, it's **IMPERATIVE** to make **ALL** the following controls:

- **Stick back** => **elevator up**
- **Stick forward** => **elevator down**
- **Stick left** => **left aileron up and right aileron down**
- **Stick right** => **right aileron up and left aileron down**
- **Push right foot** => **rudder right**
- **Push left foot** => **rudder left**

-Fasten the safety harness

-Check the doors are locked

Before any engine starting action, it is essential to check there is nobody around the aircraft, especially in the propeller area.

5-2.1 : Start engine cold

- check open tank vent
- give the squeeze bulb a few pumps, or start the electric pump (optional), to fill the carburetor bowl
- check switch is "OFF"
- pull the propeller through 10 -15 turns (20 to 25 in very cold weather)
- choke lever "ON", throttle : closed

Note: fitting the optional priming set spares you this procedure.

- turn ignition "ON", clear all spectators from front and sides of propeller
- pull starter rope or push on electric starter button

This may be done while seated. Place left foot on rudder bar and hold starter handle in both hands.

If this feels inconvenient, start from outside but make sure you have a competent helper in the cockpit, ready to keep the aircraft from moving forward.

- as soon as engine is running, throttle to half-RPM and warm up for a few minutes, moving choke to "OFF" gradually.

5-2.2 Start engine hot

- if the engine has been running quite recently, simply turn ignition "ON", choke "OFF", throttle closed, and start.

The engine will start instantly.

- if more than 15 minutes have passed since the engine was stopped, start same as just above, but with choke "ON".

Move choke to "OFF" immediately when engine starts.

CAUTION! NEVER TAKE OFF WITH CHOKE "ON":

This would make the engine lose power very quickly and might result in engine stoppage on take off, with foreseeable consequences!

If the engine will not start cold, your spark plugs probably need replacing.

Otherwise, refer to the manufacturer's manual.

5.3 : Before take-off

Check:

- altimeter set
- check controls move freely and to the stops
- trim tab : centered
- both seat belts fastened
- parachute: control box plugged and tested (optional)
- enough fuel in tank: never take off with less than 10 liters (2,64 US gals, 2,2 Imp.)
- Clearance: approach and runway clear
- radio check if required

5.4 : Take-off

- Runway clear, and of sufficient length
- Run up at half RPM, check temperatures
- Check both ignition circuits at half-RPM. Drop should not exceed 300 RPM
- electric fuel pump "ON" (option)
- brake "ON" for full throttle test. (less if aircraft moves forward)
- throttle closed all the way : engine should not stop
- apply full throttle gradually
- stick slightly back to ease nosewheel up
- check you are tracking straight
- slowly rotate at about 70 km/h
- maintain 90 km/h through climb-out
- maintain full throttle to 150 m (500 ft)
- electric fuel pump "OFF" ("ON" may cause excess fuel consumption)
- to use the flaps on take off allows a reduction of minimum speed of:
 - 5 km/h (approx 3 mph) in the first position (do not exceed 120 km/h with flaps in the first position)
 - 10 km/h (approx 6 mph) in the second position (do not exceed 110 km/h with flaps in the second position)

5.5 : Climb

- maintain air speed at 90 km/h
- check temperatures
- do not exceed specified limits

5.6 : Turns

The aircraft enters turns easily and without much adverse yaw.

Control your angle of bank at all times, and at first, use little amounts of bank: 10° in final to begin with.

Never forget that stall speed increases with bank.

You will soon come to enjoy the aircraft's excellent maneuverability.

However, always keep in mind that aerobatic flight in ultralights is **PROHIBITED!**

5.7 : Flight in turbulences

At first, fly only in calm air or light winds. Flying in turbulence is advised only after a certain degree of experience has been achieved. Keep your airspeed reasonable: 100 to 110 km/h is the recommended speed for comfortable flying in these conditions. Do not counter all the little aircraft's excursions away from a perfectly level attitude.

X-AIR Hanuman has enough sweep-back and dihedral to give it positive stability.

In high winds, keep in mind the gradient effect, which may lower wind speed close to the ground, and the inertia encountered upwind and downwind in the turn. Keep a reasonable angle of bank, and your airspeed at or above 90 km/h (50 mph).

5.8 : Stall

The best way to get to know your aircraft is to practice the stall. You will first have to climb to a safe altitude, minimum 250m (820ft), clear the area by doing a 180-degree turn, and begin the stall, engine at idle.

Practicing the stall and recovery will help you acquire the proper reactions and reduce altitude lost in an unexpected stall.

5-8.1 : Stall power off (idle)

First of all, make sure you are pointing upwind and the area is clear. When you come to the stall speed indicated in the specs sheet, corrected as per load and density altitude, the aircraft's handling becomes mushy, as the stick is pulled back slowly, keeping the wings level and flight symmetrical.

Recovery is attained very simply by reducing wing incidence (release back pressure), and adding power slowly.

As speed increases past 90km/h, pull back and level off gently.

Make sure you do not reach excessive speeds during recovery.

5-8.2 : Stall full throttle

With power on, stall is achieved at a higher angle of attack and the break occurs more abruptly; recovery in two seater configuration will lose you 30m (150ft).

5-9 Cruise

Choose the desired power setting for level flight between 90 and 140 km/h, depending on model and load.

5-10 : Descent-Landing

To descend, reduce power for 90km/h at full load.

to use the flaps on landing allows:

- on first position, an increase of minimum speed of 5 km/h
(do not exceed 120 km/h with flaps on first position)
- on second position, a reduction of 2 km/h10 km/h
(do not exceed 110 km/h with flaps on second position)
- on third position, a reduction of 9 km/h
(do not exceed 90 km/h with flaps on third position)

Keep in mind that speed is controlled with the stick and angle of descent with the throttle. Keep a safe margin and end your approach with a power off (idle) descent, then flare off. In off-field landings, this procedure will allow you to retain enough altitude until the last moment to avoid a hidden object, such as a fence or large rock....

A flat approach, airplane style, should be reserved to airfields with a well cleared, open approach.

The flare-out itself is straightforward. Keep some power on for comfort, and keep the aircraft tracking straight.

Remember: on an ultralight, the rudder remains effective down to very low speeds.

Once the main wheels are on the ground, keep pulling back on the stick until the nosewheel touches down also.

This will slow down the aircraft faster and will keep the nosewheel from hitting a bump too hard.

If your landing seems a bit chancy, never hesitate to add full power and go around.

The following is the easiest method to calculate best approach speed (V.A) for short field landings:

$$V.A = (V_{min} \times 1,3) + 1/2 \text{ windspeed} + (V_{gusts} - V_{windspeed})$$

V_{min} is indicated in the specs sheet.

For example, at full load : WIND : 25 km/h (15 mph) ; GUSTS : 35km/h (22 mph)

$$V.A = (63 \times 1,3) + 12,5 + (35 - 25)$$

$$V.A = 104,4 \text{ km/h}$$

Check before landing

No aircraft on approach or ready to take-off

Brakes free

Idle RPM, givrage, carb heat (if installed)

Fuel pump (if installed)

5-11 : Crosswind

Never take off with a 90° crosswind higher than indicated in the specs sheet: 25km/h unless you are thoroughly experienced on your aircraft.

In crosswind landings, lower your wing into the wind, and add enough opposite rudder to keep your aircraft straight down the strip (side slip).

Keep heading straight, touchdown with the upwind wheel first, then decrease your angle of bank and lower the other wheel slowly.

This maneuver can be used with a minimal amount of practice.

IMPORTANT NOTICE:

Always keep in mind that any aircraft may experience unexpected engine failure.

Hence, make sure you always have enough altitude to be able to pick as safe an emergency field as possible.

Never overfly built up or hostile areas such as forests, swamps, etc... without an added margin of altitude to be able to reach safer terrain in case of engine failure.

The same applies to your choice of maneuvering speed, especially in phases of flight which allow no room for improvisation (take off, climb out, landing).

Give yourself an ample safety margin; you will never regret it.

5-12 : Stopping the engine

On the ground:

Let the engine cool down for 30 seconds at half RPM before turning off the ignition.

- parking brake on
- radio and intercom: off
- all switches: off
- never close the fuel shut off (if fitted).

5- 13 : Parking and storage

(It is preferable to keep the X-AIR Hanuman parked inside a hangar)

If the X-AIR Hanuman has to be left outside unattended:

- point the aircraft into the wind, and put the brake on
- attach the stick with both safety harnesses
- immobilize the rudder with a control lock or other
- tie down the wings from the top of the struts to a "corkscrew "anchor in the ground
- similarly, tie down the propeller shaft
- block the wheels
- in Summer, shade the instrument panel with an aluminum/Mylar film.

5-14 : Performances (m = 450 kg)

The performance figures found in the following annexes represent averaged measured values.

However, take into consideration that performance will vary with the power plant fitted on each aircraft.

Performances at take off are greatly influenced by air density. Higher altitude and/or temperature will affect results.

To clear 15m (approx.50ft) after take off, it is best to reach 85-90 km/h before you come back on the stick.

This will mean a longer roll, but will eventually result in a shorter distance to clear 15m (50 ft).

Fuel consumption may vary with the mixture setting. Range will be estimated from the amount of fuel in the tank, the wind and a minimum safety reserve of 30minutes.

Best gliding speed is lower if weight is lower. If the actual weight is 30% below maximum, the best gliding speed will be 15% lower than normally specified.

Landing distance (to clear 15m) can be considerably shortened by side slipping, with stick into the wind and opposite rudder. Practice with a qualified instructor is mandatory.

SECTION 6 : Emergency procedures

6-1 Engine failure - Emergency landing

6-1.1 : Before take-off, when taxiing

- throttle down
- brake
- cut off engine ignition

6-1.2 : During take-off

- set airspeed at 100 km/h
- land straight ahead; only minor course changes should be made, to avoid obstacles.
- do not attempt to fly back to the runway: more often than not, you do not have enough height above ground to do so safely.

6-1.3: In flight

Note: the ultralight flight being operated always considering this possibility, you must be close to a possible landing ground.

- check to see if the engine did not stop because of inadvertent action on:
 - engine ignition switch
 - throttle
 - fuel shut off
 - try to use the emergency fuel pump (black bulb) or start the electric fuel pump (if fitted)
 - airspeed: 100 km/h (you get 10 points of fineness)
 - look for a suitable landing field
 - seatbelts tight, helmets secured
 - if you have enough altitude, flying downwind will allow to cover a greater distance, increasing your chances of finding a suitable field.
 - If the field is flat, land into the wind
 - if the ground is reasonably level, putting stick forward all the way will shorten your run
 - if braking distance is restricted, full rudder into the wind
- Note: In a 15 km/h wind (8 knots), the energy to be absorbed by the brakes will be 2,5 higher landing downwind than upwind.
- brake hard

6-2 Fire

6-2.1 : Engine fire

- close the fuel shut off (if fitted)
- stop the electric pump if it is on (if fitted)
- open full throttle
- cabin heating: off (if fitted)
- if possible, ask for help on the ground (fire brigade)
- land as soon as possible

6-2.2 : Fire in cockpit

- close heating and ventilation
- cut off auxiliary electric supply
- if necessary, cut off engine ignition and shut off the fuel line
- land as soon as possible

6-2.3 : Electric fire

- close heating and ventilation
- cut off auxiliary electric supply
- if necessary, cut off engine ignition and shut off the fuel line
- land as soon as possible

6-3 : Regulator failure

Failure of the battery regulator may cause overheating of the battery and gas release.

- pull out the charge fuse
- open the doors
- land as soon as possible

6-4 : Landing with elevator inoperative

- control the aircraft with the trim tab
- move the throttle very slowly while trimming with the tab
- pick a fairly long landing field
- set airspeed at 80 km/h (50mph) and 1,5m/s (300ft/mn) for final approach (depending on wind and turbulence, a higher airspeed may be needed)
- flare with the trim tab, keeping off the ground as long as possible, without throttling back
- immediately on touchdown, cut power

6-5 : Emergency landing with engine

(due to weather conditions or imminent lack of fuel)

- look for an appropriate landing site: check for possible obstacles (trees; power lines, fences); observe the slope of the field
- make a full 360° turn over the field; the amount and direction of drift during the turn will indicate the speed and direction of the wind.
- overfly down low, into the wind, to make a thorough inspection of the field
- seatbelts tight, helmets secured
- make a normal landing
- immediately on touch down, cut engine ignition
- brake hard

6-6 : Emergency landing on water

CAUTION : it is difficult to estimate height above water!!

Get your passenger and yourself psychologically prepared for landing on water, and try to pick a landing course that will make swimming ashore easiest.

Unlock the doors.

Be prepared to unfasten your safety harness. (Same for your passenger)

Touch down nose-up, as slowly and gently as possible.

Once in the water, stay calm; leave the aircraft without taking anything with you. **X-AIR F** is made up of water resistant materials, so that it will almost always be possible to retrieve it and get it in the air again with a thorough rinse in fresh water and a good dry out.

6-7 : Emergency landing on trees

Prefer one or several low, bushy trees. Belts and helmets tight.

Keep some speed on in final, as the air is often turbulent next to the trees. Pull up sharply to break your speed as soon as you hear contact with the branches. Good luck!

6-8 : Flight in hard rain

If the windshield fogs up, wipe with a soft cotton rag.

Throttle down to limit wear on the propeller.

Try to fly away from the rain.

6-9 : Flight in icing conditions

Although flying in icing conditions is prohibited; you may be caught in such conditions.

Proceed as follows:

- carburetors heat: "ON" (if fitted)
- turn around or change altitude for a less critical air temperature
- increase power to reduce icing to minimum
- plan on landing on the nearest airfield; if ice is building up fast, land off-field
- ice on the leading edge increases your stall speed
- approach speed depending on thickness of ice: 80 to 90 km/h (50 to 56 mph); fly a shallow, "airplane" type descent, with engine at high revs.

6-10 : Unvoluntary spin

Use the following procedure to recover from an involuntary spin:

- opposite rudder, release when rotation stops
- let stick move freely (to neutral pitch, slight roll with the spin)
- pull out gently, staying within the flight envelope.

IMPORTANT NOTE

At very low speed, control the aircraft with rudder only.

6-11 : Use of parachute

the parachute is the last solution to save lives or limit injuries of pilot and passenger of the airplane.

Its use can be necessary in extreme emergency situations like: collision in flight, structure or control failure, faintness or incapability of the pilot, engine failure over very hostile land, etc...

- Use** -
- check : safety harness tight
 - engine off
 - press parachute handle immediately
 - close fuel shut off (if fitted)
 - radio you position

If you cannot get radio contact, switch to 121,50 MHz (emergency channel), and give your position.

IMPORTANT : Never forget to remove the safety pin from the handle before take off and to replace it after landing.

(For models fitted with a parachute)

If you are unable to regain control of the aircraft (collision, airframe failure) :

NOTE CONCERNING BALLISTIC PARACHUTES

Speed at opening exerts extremely high strains on the parachute.
The user should inquire from the parachute manufacturer if the characteristics of parachute(s) are compatible with the performances of the airplane

Maintenance : Follow instructions of maintenance manual of parachute manufacturer.

SECTION 7 : Accessories and options

NOTE : Since RAND KAR is constantly developing new accessories, we reserve the right to alter the design and specification of our products. We also reserve the right to substitute or withdraw any kind of equipment presented in this document without any prior notice.

For complete, up-to-date information, contact RAND KAR or your **X-AIR Hanuman** dealer for the latest comprehensive list of accessories.

7- 1 :List of manufacturer-authorized options and accessories for other, special uses of X-AIR Hanuman

The two-seater model can be used for the special applications, professional or not, to be found in the following, non exclusive list:

- Bi-floats, amphibian bi-floats, hull, amphibious hull, snow skis, all surveillance missions, aerial photography, video or cinema, teledetection, towing of advertising banners, agri-spraying of products in liquid or powder form, transportation of medical supplies or casualties, pilot training or recreational flights, rental for diverse uses; the aircraft may be equipped with a great number of accessories designed to increase comfort or safety. No restriction need be applied in the fitting of special use accessories and options, other than those mentioned in the installation manuals of those options.

Use advices: It is strongly recommended to get informations from an experienced pilot in all these different following cases before flying with options.

7-1.1 : Skis

During preflight inspection, pay special attention to the sandow attachments and those holding the skis in approach position.

During take off, make sure the runway does not have too much lateral slope, which might cause the aircraft to deviate from the centerline.

Before landing, beware of faulty estimation of height above snow-covered terrain.

The absence of contrast, termed "white out", tends to give a deceptive impression of height.

7-1.2 : Floats

At take off, choose a course as closely upwind as possible. Keep tracking straight as you give power slowly. The stick must be kept at neutral, avoiding any wave-induced oscillations.

When taking off in a swell, choose a course that gives you the best compromise between the wind direction and that of the waves.

In the hull version, keep the wings level when fast taxiing on water, to keep the sponsons from hitting the water. For take off, stick back all the way, power on slowly, to full.

The aircraft will "climb on the step" in a few yards. Then bring the stick forward to level the aircraft.

Once the aircraft has reached a stable take off attitude, maintain this during acceleration, observing the flight attitude rather than the position of the stick.

When **X-AIR Hanuman** has reached lift off speed, it will take off on its own. Do not try to unstick it from the water, this could prove very ... wet! After accelerating in ground effect, start a normal climb.

In flight, keep in mind the aircraft in hull version is often heavier than the land version. Take this into account when selecting your approach speeds.

When landing, come in a little faster than with the land version, and prefer power-on to power-off landings.

After the flare off, skim the water, with the same attitude as you had for take off, always keep some power on and let the aircraft settle slowly rather than bringing it to the stall.

As soon as the hull touches down, reduce power to idle and try to maintain the same attitude until the aircraft stops.

When landing with power on, throttle down slowly to avoid burying the nose.

In case of engine failure, set up 100km/h and land upwind with the shallowest angle possible.

Wind direction can be seen easily, since moored boats always face into the wind when there is no current.

In all cases, take the direction of the swells into account.

When docking, never step on the forward part of the floats: if the aircraft is still moving, this is sure to make it flip over!

A capsized aircraft should always be moved very slowly. Damage in this case occurs almost always during towing or pulling out of the water.

Have the aircraft facing the shore, with the propeller parallel to the wings.

Attach ropes to the landing gear and the after end of the keel assembly, then pull very slowly until the aircraft is back on its floats.

Immediately rinse off the airframe and the fabric parts in fresh water, and the engine in diesel oil. The airframe's aluminum alloy is remarkably resistant to salt water, as long as you observe correct seaplane maintenance procedures daily, and especially after a capsized.

Before a flight to altitudes greater than 500m (1600ft) loosen the access hatches to avoid problems during descent; pressure differential in the floats or hull might cause damage on landing.

A few words on porpoising, dreaded by the novice seaplane pilot : it is an oscillation happening mainly on take off, which tends to increase and may even cause the aircraft to flip over.

It is generated by faulty pitch control (too much nose up or down) at the moment when the aircraft climbs on the step.

To stop porpoising, you must either abort take off, or increase the pitch deliberately before reducing it to normal.

Never try to "hunt" with the stick (countering the pitch, up, then down). This would only amplify the oscillation.

7-1.3 Banner towing

Make sure the tow hook is properly secured on the centerline.

Two technics are possible for towing:

- **Direct pick up** of the banner at take off, with a minimum rope length of 70m (230 ft) The banner is stretched in front of you along the center of the runway.

As soon as the banner leaves the ground, level off and accelerate, and stay prepared to release all through take off.

- **Banner pick up with a hook :**

This is a more complex maneuver, but it is safer than the one described above.

(Engine failure during take off while towing a banner requires lightning reflexes).

Line up at 100km/h to pick up the banner, and watch for any drift of the hook. Climb immediately after the banner has been picked up.

While towing, maintain 70-80km/h (45-50mph) to keep the letters nicely spaced.

In case of engine failure, release the banner as soon as you are over a vacant zone.

7-1.4 : Crop spraying

All information concerning maintenance of this equipment will be found in the relevant manual.

The increased drag due to this equipment lowers your maximum speed by +or- 15km/h (9mph).

You are advised to take on no more than 120 liters (32US, 26 Imp gals). Keep in mind that low flight is the most difficult and dangerous kind of flying.

Before spraying, check all the obstacles along the flight path.

7-1.5 : Photography, movie and video equipments

No heavy outside equipment shall be installed outboard of the upper wing strut fitting. Please contact RAND KAR for any such installation.

No additional safety recommendation is needed.

However, note that for all uses calling for photo, movie or video equipment, we advise that it be very safely secured, as it might cause serious damage or injury if it came loose at landing or in flight.

7- 2 : Effects of the equipment mentioned above on flight parameters and performances of the aircraft

7-2.1 Snow skis

Top speed is approximately 10km/h lower (6mph).

7-2.2 Floats or hull (only with engines of more than 60 hp)

Top speed at maximum load in decreased by approximately 10km/h (6mph) due to additional drag.

Take off distance at maximum load	150 m
Maximum speed.....	120km/h
Minimum sink	4m/s at 70km/h

7-2.3 Banner towing set (with engines of more than 60 hp only)

Banner towing is basically a question of practice. The effect of a banner depends on its size.

7-2.4 Agri-spraying equipment (with engines of more than 60 cv only)

Top speed at maximum load is lowered by approximately 10km/h (6mph).

7-2.5 Ballistic parachute

IMPORTANT NOTE : Installation of the parachute must be done under supervision by, and with the express agreement of RAND KAR. We reserve the right to ask for removal of this equipment in case of faulty installation by the user.

You are strongly advised to send RAND KAR photographs of your installation.

Using additional options and accessories decreases the useful load.

Always make sure you do not exceed the maximum load at take off.

Generally, when flying at maximum load you should always observe the mandatory airspeed compatible with the load and prevailing weather conditions (altitude, atmospheric pressure, temperature).

SECTION 8 : Maintenance

8-1 Taking down and transport

Preparing the aircraft for transport on a trailer or for off airport storage is a simple operation that needs two people and about 1/2 an hour.

It's recommended to proceed as follows:

To avoid losing the parts removed, re-fit immediately the screws, nuts, pins and rings back into their own parts immediately on removal.

-Disconnect ailerons control tubes in the cockpit.

-Disconnect flaps control tubes from their horns.

-Each wing strut and jury strut has its own place, so mark them for easy assembly.

-Remove the jury struts from the wings struts.

In case of a ventimeter sender on the wing strut, disconnect the ventimeter hose from the instrument and roll it on the wing strut.

-One person hold up the wing at its tip. It will help if they lightly move or twist the wing, following the suggestions of his partner to make the pins removal easier.

 Disconnect the rear wing strut from the trailing edge.

 Disconnect the front wing strut from the leading edge.

 Disconnect the leading edge.

 Disconnect the trailing edge.

 Remove the wing.

 Disconnect the wing struts from the cockpit base.

-Proceed the same way for the second wing.

In some countries, it's necessary remove the stabiliser, to reduce the width, according to the road regulations:

-Disconnect the tips of the elevator fork from their control levers on the elevator assembly.

-Remove the rings that secure the lower stab cables under the fuselage.

-Screw the bolt that fit the upper stabiliser cables in the fin leading edge to have enough lack in these cables to remove them.

-Remove the two half-stabiliser.

In the case of transport on a trailer, it is very important to protect with foam all the parts of the aircraft that are in contact with other parts of the aircraft or in contact with the trailer, most damage to aircraft is done on due to travelling vibrations and accidents.

Fit the cables to avoid loss. Immobilize the rudder.

Don't forget to check the load a last time before leaving.

To assemble, proceed in the reverse order, use new nuts, control the path of the cables in their pulleys and don't forget to make the pre-flight inspection before flying.

8-2 Airframe maintenance (to be carried out periodically as per table below)

The following maintenance tables never can replace the pre-flight check, obligatory before every take-off.

Nota: these maintenance periods concern only the aircrafts flying under a continental climate and being stocked under hangar. The aircrafts submitted to other conditions will have to be more frequently checked.

Périodicity	1 month 50 h	6 month 150 h	1 year 300 h	2 years 600 h	5 years 900 h
<i>Wings, control surfaces and empennage fabrics</i>			V		C
<i>Fork and landing gear</i>					
Tyres pressure (1.8)	V				
Tyres wear	V				
Brakes wear	V				
Front fork and main gear shok absorbers	V				
<i>Windsreen</i>		V			
<i>Controls</i>					
Ailerons cables	V	L			C
Ailerons tubes and tubes-and socket-joints	V	L			C
Rudder cables	V		V		C
Handle stick joint	L				C
Elevator control	V		V		C
Choke and throttle cables	V	L			C
Flaps control	V				C
<i>Electric wiring and fuel line</i>					
<i>Take care of scrapping and wear</i>					
Electric wires		V			
Battery		V			
Fuel hoses	V				R
Handle fuel pump	V			R	
Fuel filter	V	R			
Fuel tank		V			
<i>Control surfaces, trim, mobile parts</i>					
axels	L				C
Bellcrank / quick links		V			C
Câble trim	L				C
<i>Bolts</i>			V		C

NOTA :

- V = Verify and replace if necessary
- R = Replace
- L = Lubricate, verify and replace if necessary
- C = Control by a competent professional and replace if necessary

Maintenance every 50 hours or 1 month

Périodicity	1 month 50 h	Date control	Date control	Date control	Date control
<i>Wings, control surfaces and empennage fabrics</i>					
<i>Fork and landing gear</i>					
Tyres pressure (1.8)	V				
Tyres wear	V				
Brakes wear	V				
Front fork and main gear shok absorbers	V				
<i>Windsreen</i>					
<i>Controls</i>					
Ailerons cables	V				
Ailerons tubes and tubes-and socket-joints	V				
Rudder cables	V				
Handle stick joint	L				
Elevator control	V				
Choke and throttle cables	V				
Flaps control	V				
<i>Electric wiring and fuel line</i>					
<i>Take care of scrapping and wear</i>					
Electric wires					
Battery					
Fuel hoses	V				
Handle fuel pump	V				
Fuel filter	V				
Fuel tank					
<i>Control surfaces, trim, mobile parts</i>					
axels	L				
Bellcrank / quick links	V				
Câble trim	L				
<i>Bolts</i>					

NOTA :

V = Verify and replace if necessary
R = Replace
L = Lubricate, verify and replace if necessary
C = Control by a competent professional and replace if necessary

Maintenance every 150 hours or 6 month

Périodicity	6 month 150 h	Date control	Date control	Date control	Date control
<i>Wings, control surfaces and empennage fabrics</i>					
<i>Fork and landing gear</i>					
Tyres pressure (1.8)	V				
Tyres wear	V				
Brakes wear	V				
Front fork and main gear shok absorbers	V				
<i>Windsreen</i>					
<i>Controls</i>					
Ailerons cables	L				
Ailerons tubes and tubes-and socket-joints	V				
Rudder cables	L				
Handle stick joint	V				
Elevator control	L				
Choke and throttle cables	L				
Flaps control	V				
<i>Electric wiring and fuel line</i>					
<i>Take care of scrapping and wear</i>					
Electric wires	V				
Battery	V				
Fuel hoses	V				
Handle fuel pump	V				
Fuel filter	R				
Fuel tank	V				
<i>Control surfaces, trim, mobile parts</i>					
axels	L				
Bellcrank / quick links	V				
Câble trim	L				
<i>Bolts</i>					

NOTA :

- V = Verify and replace if necessary
- R = Replace
- L = Lubricate, verify and replace if necessary
- C = Control by a competent professional and replace if necessary

Maintenance every 300 h or 1 year

Périodicity	1 year 300 h	Date control	Date control	Date control	Date control
<i>Wings, control surfaces and empennage fabrics</i>	V				
<i>Fork and landing gear</i>					
Tyres pressure (1.8)	V				
Tyres wear	V				
Brakes wear	V				
Front fork and main gear shock absorbers	V				
<i>Windsreen</i>					
<i>Controls</i>					
Ailerons cables	L				
Ailerons tubes and tubes-and socket-joints	V				
Rudder cables	L				
Handle stick joint	V				
Elevator control	L				
Choke and throttle cables	L				
Flaps control	V				
<i>Electric wiring and fuel line</i>					
<i>Take care of scrapping and wear</i>					
Electric wires	V				
Battery	V				
Fuel hoses	R				
Handle fuel pump	V				
Fuel filter	R				
Fuel tank	V				
<i>Control surfaces, trim, mobile parts</i>					
axels	L				
Bellcrank / quick links	V				
Câble trim	L				
<i>Bolts</i>	V				

NOTA :

V = Verify and replace if necessary
R = Replace
L = Lubricate, verify and replace if necessary
C = Control by a competent professional and replace if necessary

Maintenance every 600 h or 2years

Périodicity	2 years 600 h	Date control	Date control	Date control	Date control
<i>Wings, control surfaces and empennage fabrics</i>	<i>V</i>				
<i>Fork and landing gear</i>					
Tyres pressure (1.8)	<i>V</i>				
Tyres wear	<i>V</i>				
Brakes wear	<i>V</i>				
Front fork and main gear shok absorbers	<i>V</i>				
<i>Windsreen</i>					
<i>Controls</i>					
Ailerons cables	<i>L</i>				
Ailerons tubes and tubes-and socket-joints	<i>V</i>				
Rudder cables	<i>L</i>				
Handle stick joint	<i>L</i>				
Elevator control	<i>V</i>				
Choke and throttle cables	<i>L</i>				
Flaps control	<i>V</i>				
<i>Electric wiring and fuel line</i>					
<i>Take care of scrapping and wear</i>					
Electric wires	<i>V</i>				
Battery	<i>V</i>				
Fuel hoses	<i>V</i>				
Handle fuel pump	<i>R</i>				
Fuel filter	<i>R</i>				
Fuel tank	<i>V</i>				
<i>Control surfaces, trim, mobile parts</i>					
axels	<i>L</i>				
Bellcrank / quick links	<i>V</i>				
Câble trim	<i>L</i>				
<i>Bolts</i>	<i>V</i>				

NOTA :

V = Verify and replace if necessary
R = Replace
L = Lubricate, verify and replace if necessary
C = Control by a competent professional and replace if necessary

Maintenance every 900 h or 5 years

Périodicity	5 years 900 h	Date control	Date control	Date control	Date control
<i>Wings, control surfaces and empennage fabrics</i>	<i>C</i>				
<i>Fork and landing gear</i>					
Tyres pressure (1.8)	<i>V</i>				
Tyres wear	<i>V</i>				
Brakes wear	<i>V</i>				
Front fork and main gear shok absorbers	<i>V</i>				
<i>Windsreen</i>	<i>V</i>				
<i>Controls</i>					
Ailerons cables	<i>C</i>				
Ailerons tubes and tubes-and socket-joints	<i>C</i>				
Rudder cables	<i>C</i>				
Handle stick joint	<i>C</i>				
Elevator control	<i>C</i>				
Choke and throttle cables	<i>C</i>				
Flaps control	<i>C</i>				
<i>Electric wiring and fuel line</i>					
<i>Take care of scrapping and wear</i>					
Electric wires	<i>V</i>				
Battery	<i>V</i>				
Fuel hoses	<i>R</i>				
Handle fuel pump	<i>R</i>				
Fuel filter	<i>R</i>				
Fuel tank	<i>V</i>				
<i>Control surfaces, trim, mobile parts</i>					
axels	<i>C</i>				
Bellcrank / quick links	<i>C</i>				
Câble trim	<i>C</i>				
<i>Bolts</i>	<i>C</i>				

NOTA :

- V = Verify and replace if necessary
- R = Replace
- L = Lubricate, verify and replace if necessary
- C = Control by a competent professional and replace if necessary

8-3 Propeller

- Frequently wash the blades with soapy water
- Repare all the little cracks with epoxy resin and sand
- Torque of M8 bolts:1.2 Kg/m

8-4 Powerplant

See maintenance instructions in the engine manufacturer's manual

8-4.1 maintenance Jabiru 2200

	25h	50h	100h	200h or 1 year	If necessary
1- Oil		R			
2- Fuel filter	V	R			
3- Air filter		V		R	
4- Oil filter			R		
5- Oil leaks	V				
6- Hoses	V			R	
7- Intake - exhaust	V				Clamps
8- Electric wiring		V			
9- Spark plugs	V		R		
10- Cylinder pressure				V	
11- Oil venting hose			V		Leaks
12- throttle drive		V			
13- Carburettor		V			Purge
14- Valves setting (after first setting of 25h)			V		
15- Torquing cylinder head (after first setting of 25h)				V	

R : Replace

V : Verify and replace if necessary

8-4.2 maintenance Rotax 912

	25h	50h	100h ou 1 an	200h	600h
Oil	R		R		
Fuel filter	V	R			
Air filter	V			R	
Oil filter	R				
Lubrication line	V			R	
Cooling line	V			R	
Intake-exhaust	V				
Electrics and ignition	V				
Spark plugs	V		R		
compressions				V	
Throttle drive	V				
Carburettors-fuel line	V				
Engine Silent-blocs	V				
Engine bolts	V				
Gearbox	V	V	V		
Valve spring tension (BT912-04)					V
Float valve (BT912-04)					V

R : Replace

V : Verify and replace if necessary

Maintenance Rotax engines		2H	10H	12,5H	25H	50H	75H	100H	125H	150H	175H	200H	225H	250H	275H
1	Tighten up the cylinder head nuts	1	X												
2	Tighten up the exhaust pipe screws	1	X												
3	Check the handlestarter rope			X											
4	Check the crown wheel of electric starter					X		X		X		X		X	
5	Check spark plugs			X											
6	Change spark plugs				X	X	X	X	X	X	X	X	X	X	X
7	Check and clean the spark plug covers			X											
8	Check ignition advance	2	X				X						X		
9	Check the contact breakers	2	X				X						X		
10	Check ignition alternator						X			X			X		
11	Change contact breakers and capacitors									X					
12	Check the belt tension		X		X	X	X	X	X	X	X	X	X	X	X
13	Grease exhaust elbow (high temperature grease)				X	X	X	X	X	X	X	X	X	X	X
14	Change exhaust springs						X			X			X		
15	Lubricate the control cables				X	X	X	X	X	X	X	X	X	X	X
16	Check balance and tracking of propeller	3			X	X	X	X	X	X	X	X	X	X	X
17	Change the nuts of the proppeller	4													
18	Clean and oil air filters				X	X	X	X	X	X	X	X	X	X	X
19	Clean fuel filter				X	X	X		X	X	X		X	X	X
20	Change fuel filter							X				X			
21	Check carburettors, adjust idle and throttle cables		X		X		X		X		X		X		X
22	Clean the cabs and check the inside parts					X		X		X		X		X	
23	Change needles and needles jets									X					
24	Clean and check the fuel pump						X			X			X		
25	Check oil level in gearbox				X	X	X		X	X	X		X	X	X
26	Change oil in the gearbox		X					X				X			
27	Check and change if necessary the lock washers of the gearbox (gearbox A orB)							X				X			
28	Check the 4 fitting screws of gearbox adaptor (gearbox A)							X				X			
		2H	10H	12,5H	25H	50H	75H	100H	125H	150H	175H	200H	225H	250H	275H

29	Change the lubricating oil of water pump							X				X		
30	Check cylinder heads and pistons	5					X	X		X		X		X
31	Check the gap of piston rings	6					X	X		X		X		X
32	Check pistons diameter	8					X 7	X 7		X		X 7		X 7
33	Check the wear of piston rings	8					X 7	X 7		X		X 7		X 7
34	Check vertical gap of rectangular piston ring	8					X 7	X 7		X		X 7		X 7
35	Check cylinders diameter	8					X 7	X 7		X		X 7		X 7
36	Check ovalization of cylinders	8					X 7	X 7		X		X 7		X 7
37	Change the following gaskets : base, cylinder head, intake and exhaust	9					X	X		X		X		X
38	Check pistons axles and bearings									X				
39	Check the crankcase and change the oil seals									X				
40	Major overhaul	10												

- 1 - And after each gasket change
- 2 - And after each change of contact breakers
- 3 - And after each repairing
- 4 - Following engine builder's instructions
- 5 - If carbon deposit > 0,5mm, clean

- 6 - Clean pistons and piston rings
- 7 - If use in dusty environment
- 8 - see B/S 5 UL 91
- 9 - If cylinders are removed
- 10 - Contact your ROTAX dealer