



SynchLink Bypass Switch Block

Catalog Number 1751-SLBP

This document describes how to install and use the 1751-SLBP SynchLink™ bypass switch block.

Topic	Page
Important User Information	2
SynchLink Overview	4
Installing the Bypass Switch Block	5
Wiring the Bypass Switch Block	8
Indicators	9
Mounting Dimensions	10
Hazardous Location	11
Rockwell Automation Support	12
Specifications	13

Related Publications

Publication Title	Publication Number
SynchLink Base Block Installation Instructions	1751-IN001A-EN-P
SynchLink 4-port Splitter Block Installation Instructions	1751-IN002A-EN-P
SynchLink Bypass Switch Block Installation Instructions	1751-IN003A-EN-P
ControlLogix SynchLink Module Installation Instructions	1756-IN575A-EN-P
SynchLink System Overview	1756-SO008A-EN-P
ControlLogix SynchLink Module User Manual	1756-UM521A-EN-P

Important User Information

Because of the variety of uses for the products described in this publication, those responsible for the application and use of these products must satisfy themselves that all necessary steps have been taken to assure that each application and use meets all performance and safety requirements, including any applicable laws, regulations, codes and standards. In no event will Allen-Bradley be responsible or liable for indirect or consequential damage resulting from the use or application of these products.

Any illustrations, charts, sample programs, and layout examples shown in this publication are intended solely for purposes of example. Since there are many variables and requirements associated with any particular installation, Allen-Bradley does not assume responsibility or liability (to include intellectual property liability) for actual use based upon the examples shown in this publication.

Allen-Bradley publication SGI-1.1, *Safety Guidelines for the Application, Installation and Maintenance of Solid-State Control* (available from your local Allen-Bradley office), describes some important differences between solid-state equipment and electromechanical devices that should be taken into consideration when applying products such as those described in this publication.

Reproduction of the contents of this copyrighted publication, in whole or part, without written permission of Rockwell Automation, is prohibited.

Throughout this publication, notes may be used to make you aware of safety considerations. The following annotations and their accompanying statements help you to identify a potential hazard, avoid a potential hazard, and recognize the consequences of a potential hazard:

WARNING

Identifies information about practices or circumstances that can cause an explosion in a hazardous environment, which may lead to personal injury or death, property damage, or economic loss.

ATTENTION

Identifies information about practices or circumstances that can lead to personal injury or death, property damage, or economic loss.

IMPORTANT

Identifies information that is critical for successful application and understanding of the product.

ATTENTION**Environment and Enclosure**

This equipment is intended for use in a Pollution Degree 2 industrial environment, in overvoltage Category II applications (as defined in IEC publication 60664-1), at altitudes up to 2000 meters without derating.

This equipment is considered Group 1, Class A industrial equipment according to IEC/CISPR Publication 11. Without appropriate precautions, there may be potential difficulties ensuring electromagnetic compatibility in other environments due to conducted as well as radiated disturbance.

This equipment is supplied as "open type" equipment. It must be mounted within an enclosure that is suitably designed for those specific environmental conditions that will be present and appropriately designed to prevent personal injury resulting from accessibility to live parts. The interior of the enclosure must be accessible only by the use of a tool. Subsequent sections of this publication may contain additional information regarding specific enclosure type ratings that are required to comply with certain product safety certifications.

See NEMA Standards publication 250 and IEC publication 60529, as applicable, for explanations of the degrees of protection provided by different types of enclosure. Also, see the appropriate sections in this publication, as well as the Allen-Bradley publication 1770-4.1 ("Industrial Automation Wiring and Grounding Guidelines"), for additional installation requirements pertaining to this equipment.

SynchLink Overview

We designed the SynchLink system to provide the synchronization and coordination of drive and motion control applications that are based on ControlLogix™ and PowerFlex 700s™ stations.

About the SynchLink Bypass Switch Block

Use the SynchLink bypass switch block in SynchLink daisy-chain configuration where a station, or group of stations, needs to be temporarily disconnected from the SynchLink system without physical re-configuration of the cable system. The bypass switch block is DIN rail-mounted and is housed in a two-piece plastic enclosure. Figure 1 identifies the components of the bypass switch block.

Figure 1 - Components of the bypass switch block

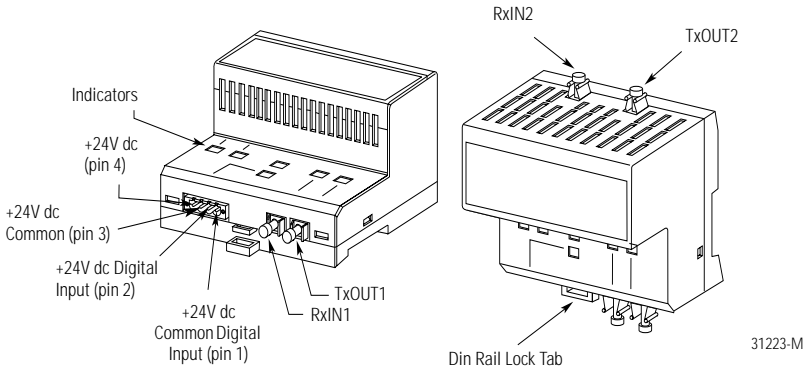

The bypass switch block has two modes of operation, pass-through and bypass. The operational mode is determined by the state of the 24V dc digital input that is driven by the local SynchLink station.

The pass-through mode is entered when the digital input is ON. In this mode, optical signals from the upstream station are received at the receiver port RxIN1 and retransmitted to the local station via the transmitter port TxOUT2. Optical signals generated by the local station are received at the receiver port RxIN2 and retransmitted to the downstream station via the transmitter port TxOUT1. There is no re-timing or signal regeneration in this mode.

The bypass mode is entered when the digital input is OFF. In this mode, signals received from the upstream station at the port RxIN1 are converted to electrical signals, re-timed, and retransmitted to the downstream station via the port TxOUT1.

The bypass switch block has no capabilities to detect or correct communication error conditions that may exist during the course of pass-through or bypass operation. The bypass switch block has no ability to report any abnormal conditions to the local station.

Prevent Electrostatic Discharge

ATTENTION

This equipment is sensitive to electrostatic discharge, which can cause internal damage and affect normal operation. Follow these guidelines when you handle this equipment:

- Touch a grounded object to discharge potential static.
 - Wear an approved grounding wriststrap.
 - Do not touch connectors or pins on component boards.
 - Do not touch circuit components inside the equipment.
 - If available, use a static-safe workstation.
 - When not in use, store the equipment in appropriate static-safe packaging.
-

Installing the Bypass Switch Block

To install the switch block on the DIN rail:

1. Position the switch block on the 35×7.5mm DIN rail (Allen-Bradley catalog number 199-DRI) at a 30° angle.

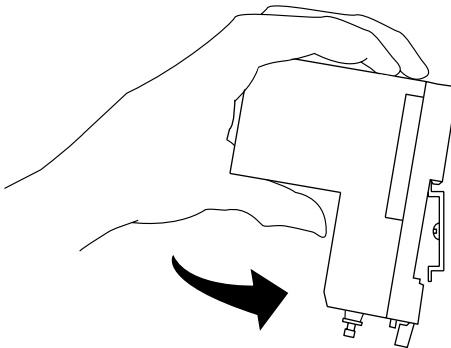

31203a-M

2. Hook the lip of on the rear of the switch block onto the top of the DIN rail and rotate the switch block onto the rail.

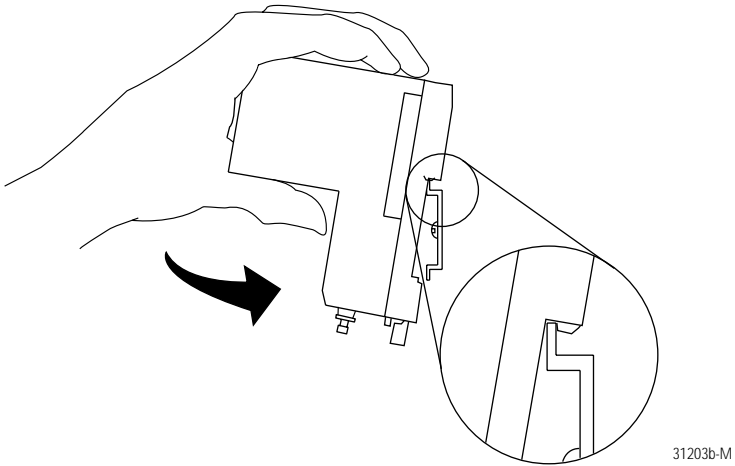

3. Press the bypass switch block down to the DIN rail until flush.

The locking tab should snap into position and lock the switch block to the DIN rail. If the tab does not snap into position, follow step 4. If the tab does snap into position, proceed to step 5.

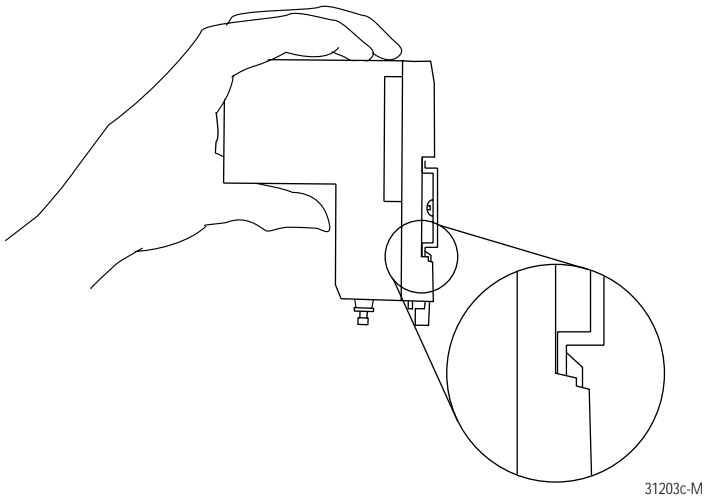

4. Use a screwdriver to move the locking tab down while you press the switch block flush onto the DIN rail. Release the locking tab to lock the switch block into place. If necessary, push up on the locking tab to lock the switch block into place.
5. Use DIN rail end anchors to secure the switch block. (Allen-Bradley catalog number 1492-EAH35)

ATTENTION

Be certain that you secure the bypass switch block with DIN rail anchors. Failure to do so may result in loss of communication and/or damage to switch block.

IMPORTANT

If you exceed the switch block's power limit, you may cause damage to the bypass switch block.

6. Connect the switch wiring as shown in Wiring the Bypass Switch Block Block.

Wiring the Bypass Switch Block

ATTENTION



Do not look directly into the fiber ports or fiber cable. Light levels may cause damage to eyesight. The bypass switch block is a Class 1 LED product.

To wire the bypass switch block and connect power:

1. Connect pre-terminated fiber optic cables as shown.

Connect	To
RxIN1	Upstream station transmitter
TxOUT1	Downstream station receiver
RxIN2	Local station transmitter
TxOUT2	Local station receiver

2. Pre-wire the removable connector plug as shown on the switch block label or below.

Connect	To pin
+24V dc Power	4
24V dc Common	3
+24V dc Digital Input	2
24V dc Common Digital Input	1

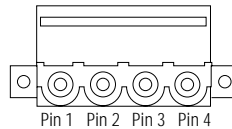

Power Supply and Digital Input Connect (front view) 31248-M

IMPORTANT

Do not connect 24V dc Common to Chassis Ground.

3. Insert the removable connector plug into the mating connector receptacle on the switch block.

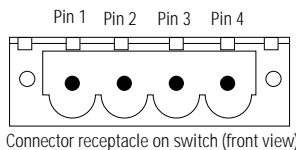

31249b-M

4. Screw the removable connector to the switch block with the left and right mounting screws.

IMPORTANT

Make sure the switch block is attached and secured prior to applying power to the switch block. Failure to do so may cause damage to the switch block.

Indicators

Figure 2 identifies the status indicators on the switch block.

Figure 2 - Status indicators

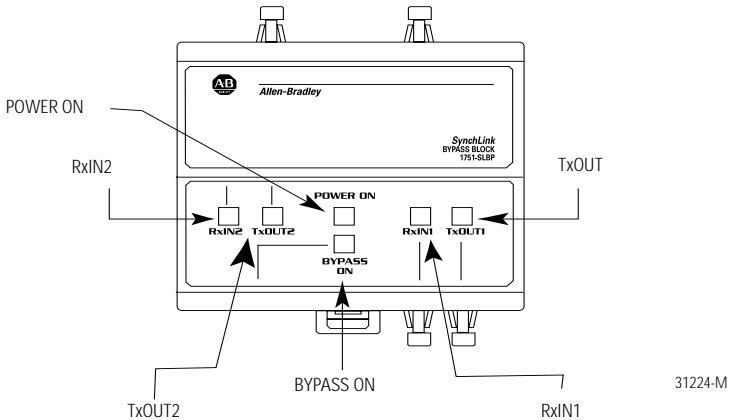

Status Indicators

Indicator	When LED is ON
Power ON	24V dc power is applied to the switch block
Bypass ON	block is in the Bypass mode
RxIN1	optical signals are received from the upstream station
TxOUT1	optical signals are transmitted to the downstream station
RxIN2	optical signals are received from the local station
TxOUT2	optical signals are transmitted to the local station

Mounting Dimensions

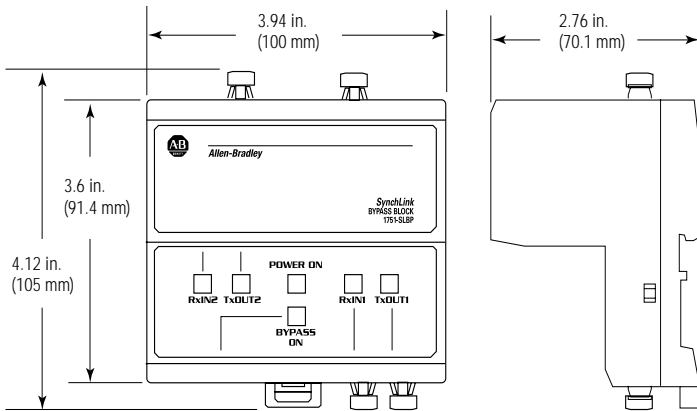

Figure 3 provides mounting dimensions for the switch block.

Figure 3 - Mounting dimensions



31234-M

Hazardous Location

<p>The following information applies when operating this equipment in hazardous locations:</p>	<p>Informations sur l'utilisation de cet équipement en environnements dangereux :</p>		
<p>Products marked "CL I, DIV 2, GP A, B, C, D" are suitable for use in Class I Division 2 Groups A, B, C, D, Hazardous Locations and nonhazardous locations only. Each product is supplied with markings on the rating nameplate indicating the hazardous location temperature code. When combining products within a system, the most adverse temperature code (lowest "T" number) may be used to help determine the overall temperature code of the system. Combinations of equipment in your system are subject to investigation by the local Authority Having Jurisdiction at the time of installation.</p>	<p>Les produits marqués "CL I, DIV 2, GP A, B, C, D" ne conviennent qu'à une utilisation en environnements de Classe I Division 2 Groupes A, B, C, D dangereux et non dangereux. Chaque produit est livré avec des marquages sur sa plaque d'identification qui indiquent le code de température pour les environnements dangereux. Lorsque plusieurs produits sont combinés dans un système, le code de température le plus défavorable (code de température le plus faible) peut être utilisé pour déterminer le code de température global du système. Les combinaisons d'équipements dans le système sont sujettes à inspection par les autorités locales qualifiées au moment de l'installation.</p>		
<p style="text-align: center;">WARNING</p> 	<p style="text-align: center;">EXPLOSION HAZARD</p> <ul style="list-style-type: none"> • Do not disconnect equipment unless power has been removed or the area is known to be nonhazardous. • Do not disconnect connections to this equipment unless power has been removed or the area is known to be nonhazardous. Secure any external connections that mate to this equipment by using screws, sliding latches, threaded connectors, or other means provided with this product. • Substitution of components may impair suitability for Class I, Division 2. • If this product contains batteries, they must only be changed in an area known to be nonhazardous. 	<p style="text-align: center;">AVERTISSEMENT</p> 	<p style="text-align: center;">RISQUE D'EXPLOSION</p> <ul style="list-style-type: none"> • Couper le courant ou s'assurer que l'environnement est classé non dangereux avant de débrancher l'équipement. • Couper le courant ou s'assurer que l'environnement est classé non dangereux avant de débrancher les connecteurs. Fixer tous les connecteurs externes reliés à cet équipement à l'aide de vis, loquets coulissants, connecteurs filetés ou autres moyens fournis avec ce produit. • La substitution de composants peut rendre cet équipement inadapté à une utilisation en environnement de Classe I, Division 2. • S'assurer que l'environnement est classé non dangereux avant de changer les piles.

Rockwell Automation Support

Rockwell Automation offers support services worldwide, with over 75 sales/support offices, over 500 authorized distributors, and 260 authorized systems integrators located throughout the United States alone, plus Rockwell Automation representatives in every major country around the world. Contact your local Rockwell Automation representative for:

- sales and order support
- product technical training
- warranty support
- support service agreements

Obtain Pre-Sales Product Support

If you need to contact Rockwell Automation for pre-sales product support, try one of the following methods:

- Call your local Rockwell Automation representative
- Network Pre-sales support line, 1.440.646.3638 (3NET)
- Pre-Sales e-mail, RACle3net@ra.rockwell.com

Obtain Technical Product Support

If you need to contact Rockwell Automation for technical assistance, try one of the following methods:

- Call your local Rockwell Automation representative
- Post-Sales Technical Support:
 - United States/Canada: 1.440.646.5800
 - Outside the United States/Canada use: <http://www.ab.com>, click on *Product Support* (<http://support.automation.rockwell.com>), under *Support Centers*, click on *Contact Information* to find phone number for your country
- Fax Back system, 1.440.646.5436 (requires a touch-tone telephone)
- Web Links <http://www.ab.com> — as a registered member, open to <http://www.ab.com/mem/technotes/techmain.html>

Specifications

Power Supply	To comply with CE Low Voltage directives, you must use a Safety Extra Low Voltage (SELV) or a Protected Extra Low Voltage (PELV) power supply to power this bypass switch block. Use a NEC/CEC Class 2 power supply in order to comply with UL and CSA requirements.
Power Supply Rating	0.1A @ 24V dc nominal
Power Supply Range	20V dc to 30V dc A regulated power supply is recommended.
Communication Rate	5M bit/s
Terminal Block Torque Requirements	5-7 inch-pounds maximum
Environmental Conditions	
Operating Temperature	0 to 60°C (32 to 140°F) ⁽¹⁾
Storage Temperature	-40 to 85°C (-40 to 185°F) ⁽²⁾
Relative Humidity	5 to 95% non-condensing ⁽³⁾
Vibration	5g @ 10-500Hz ⁽⁴⁾
Shock	Operating 30g ⁽⁵⁾ Non-operating 50g
Emissions	Group 1, Class A ⁽⁶⁾
ESD Immunity	6kV contact discharges ⁽⁷⁾ 8kV air discharges
Radiated RF Immunity	10V/m with 1kHz sine-wave 80%AM from 30MHz to 1000MHz ⁽⁸⁾ 10V/m with 200Hz 50% Pulse 100%AM at 900Mhz
EFT/B Immunity	±2kV at 5kHz on power ports ⁽⁹⁾ ±2kV at 5kHz on signal ports
Surge Transient Immunity	±2kV line-earth (CM) on shielded ports ⁽¹⁰⁾
Conducted RF Immunity	10Vrms with 1kHz sine-wave 80%AM from 150kHz to 80MHz ⁽¹¹⁾
Enclosure Type Ratings	8.0 pt
Fiber Optic Cable	
Fiber Type	200/230 micron HCS (Hard Clad Silica)
Fiber Termination Type	Versalink V-System
Assemblies	Cable assemblies can be ordered from Allen-Bradley, catalog number 1403-CFxxx (xxx = length in meters); or from Lucent Technologies, Specialty Fiber Technologies division.
Maximum Length	300 meters
Minimum Length	1 meter

Power Conductors		
Wire Size		12 gauge maximum, 24 gauge minimum (#12 AWG to 24 AWG), stranded
Category		2 ⁽¹²⁾
Maximum Length		3 meters
Digital Input		isolated, sinking
ON-State Voltage		12V dc minimum 24V dc nominal 30V dc maximum
ON-State Current		12.0mA nominal at 24V dc
OFF-State Voltage		8.0V dc maximum
Isolation Voltage		Tested to withstand 850 Vdc for 60 seconds
Conductors		use shielded two-conductor cable
Wire Size		12 gauge maximum 24 gauge minimum (#12 AWG to #24 AWG) ⁽¹³⁾
Category		2 ⁽¹²⁾
Maximum Length		10 meters
Certifications (when product is marked)		<ul style="list-style-type: none"> UL UL Listed Industrial Control Equipment CSA CSA Certified Process Control Equipment for Class I, Division 2 Group A,B,C,D Hazardous Locations CE⁽¹⁴⁾ European Union 89/336/EEC EMC Directive, compliant with: EN 50081-2: Industrial Emissions EN 50082-2: Industrial Immunity EN 61326: Meas./Control/Lab., Industrial Requirements EN 61000-6-2: Industrial Immunity C-Tick Australian Radiocommunications Act, compliant with: AS/NZS 2064: Industrial Emissions

(1) IEC 60068-2-1 (Test Ad, Operating Cold), IEC 60068-2-2 (Test Bd, Operating Dry Heat), IEC 60068-2-14 (Test Nb, Operating Thermal Shock)

(2) IEC 60068-2-1 (Test Ab, Un-packaged Non-operating Cold), IEC 60068-2-2 (Test Bc, Un-packaged Non-operating Dry Heat), IEC 60068-2-14 (Test Na, Un-packaged Non-operating Thermal Shock)

(3) IEC 60068-2-30 (Test Db, Un-packaged Non-operating Damp Heat)

(4) IEC60068-2-6 (Test Fc, Operating)

(5) IEC60068-2-27:1987, Test Ea (Unpackaged shock, ES#002)

(6) CISPR 11

(7) IEC 61000-4-2

(8) IEC 61000-4-3

(9) IEC 61000-4-4

(10) IEC 61000-4-5

(11) IEC 61000-4-6

(12) You use this category information for planning conductor routing as described in publication 1770-4.1, "Industrial Automation Wiring and Grounding Guidelines."

(13) Shielded cable required.

(14) See Product Certification link at www.ab.com for Declarations of Conformity, Certificates, and other certification details.

Allen-Bradley, ControlLogix, PowerFlex 700s, and SynchLink are trademarks of Rockwell Automation.
ControlNet is a trademark of ControlNet International.

www.rockwellautomation.com

Power, Control and Information Solutions Headquarters

Americas: Rockwell Automation, 1201 South Second Street, Milwaukee, WI 53204-2496 USA, Tel: (1) 414.382.2000, Fax: (1) 414.382.4444
Europe/Middle East/Africa: Rockwell Automation, Vorstlaan/Boulevard du Souverain 36, 1170 Brussels, Belgium, Tel: (32) 2 663 0600, Fax: (32) 2 663 0640
Asia Pacific: Rockwell Automation, Level 14, Core F, Cyberport 3, 100 Cyberport Road, Hong Kong, Tel: (852) 2887 4788, Fax: (852) 2508 1846

Publication 1751-IN003B-EN-P - September 2001

PN 957626-14

Supersedes Publication 1751-IN003A-EN-P - March 2001

Copyright © 2001 Rockwell Automation. All rights reserved. Printed in the U.S.A.