

# 3-Phase PM Synchronous Motor Vector Control Using a 56F80x, 56F8100, or 56F8300 Device

## Design of Motor Control Application

*Libor Prokop, Pavel Grasblum*

**Note:** The PC master software referenced in this document is also known as Free Master software.

## 1. Introduction

This application note describes the design of a 3-phase Permanent Magnet Synchronous Motor (PMSM) drive based on Freescale's 56F80x or 56F8300 dedicated motor control device. The software design takes advantage of Processor Expert™ (PE) software.

PM synchronous motors are very popular in a wide application area. The PMSM lacks a commutator and is therefore more reliable than the DC motor. The PM synchronous motor also has advantages when compared to an AC induction motor. Because a PMSM achieves higher efficiency by generating the rotor magnetic flux with rotor magnets, a PMSM is used in high-end white goods (such as refrigerators, washing machines, dishwashers); high-end pumps; fans; and in other appliances which require high reliability and efficiency.

This application creates a speed closed-loop PM synchronous drive using a vector control technique. It serves as an example of a PMSM control design using a Freescale hybrid controller with PE support. It also illustrates the use of the PE's dedicated motor control libraries.

This application note includes basic motor theory, system design concept, hardware implementation and software design, including the PC master software visualization tool.

## Contents

1. Introduction .....	1
2. Advantages and Features of Freescale's Hybrid Controller .....	2
2.1 56F805, 56800 Core Family .....	2
2.2 56F8346, 56800E Core Family .....	3
2.3 Peripheral Description .....	4
3. Target Motor Theory .....	6
3.1 Permanent Magnet Synchronous Motor (PMSM).....	6
3.2 Mathematical Description of PM Synchronous Motor .....	7
3.3 Digital Control of PM Synchronous Motor.....	11
4. System Concept .....	19
4.1 System Specification .....	19
4.2 Vector Control Drive Concept.....	20
4.3 System Blocks Concept.....	22
5. Hardware Implementation .....	32
5.1 Hardware Set-Up .....	32
6. Software Design .....	34
6.1 Main Software Flow Chart .....	34
6.2 Data Flow .....	39
6.3 State Diagram .....	46
7. Implementation Notes .....	51
7.1 Scaling of Quantities .....	51
7.2 PI Controller Tuning.....	54
7.3 Subprocesses Relation and State Transitions.....	55
7.4 RUN / STOP Switch and Button Control.....	55
8. Processor Expert (PE) Implementation ..	57
8.1 Beans and Library Functions.....	57
8.2 Beans Initialization .....	57
8.3 Interrupts.....	57
8.4 PC Master Software.....	58
9. Hybrid Controller Memory Use .....	60
10. References .....	60

## 2. Advantages and Features of Freescale's Hybrid Controller

The Freescale 56F80x (56800 core) and 56F8300 (56800E core) families are well suited for digital motor control, combining the DSP's calculation capability with the MCU's controller features on a single chip. These hybrid controllers offer many dedicated peripherals, such as Pulse Width Modulation (PWM) unit(s), an Analog-to-Digital Converter (ADC), Timers, communication peripherals (SCI, SPI, CAN), on-board Flash and RAM.

The following sections use a specific device to describe the family's features.

### 2.1 56F805, 56800 Core Family

The 56F805 provides the following peripheral blocks:

- Two Pulse Width Modulator modules (PWMA and PWMB), each with six PWM outputs, three Current Sense inputs, and four Fault inputs; fault-tolerant design with dead time insertion, supporting both center-aligned and edge-aligned modes
- Twelve-bit Analog-to-Digital Converters (ADCs), supporting two simultaneous conversions with dual 4-pin multiplexed inputs; the ADC can be synchronized by PWM modules
- Two Quadrature Decoders (Quad Dec0 and Quad Dec1), each with four inputs, or two additional Quad Timers, A and B
- Two dedicated general purpose Quad Timers totaling six pins: Timer C with two pins and Timer D with four pins
- CAN 2.0 B-compatible module with 2-pin ports used to transmit and receive
- Two Serial Communication Interfaces (SCI0 and SCI1), each with two pins, or four additional GPIO lines
- Serial Peripheral Interface (SPI), with configurable 4-pin port, or four additional GPIO lines
- Computer Operating Properly (COP) / Watchdog timer
- Two dedicated external interrupt pins
- Fourteen dedicated General Purpose I/O (GPIO) pins; 18 multiplexed GPIO pins
- External reset pin for hardware reset
- JTAG / On-Chip Emulation (OnCE)
- Software-programmable, Phase Lock Loop-based frequency synthesizer for the hybrid controller core clock

**Table 2-1 Memory Configuration for 56F80x Devices**

	56F801	56F803	56F805	56F807
Program Flash	8188 x 16-bit	32252 x 16-bit	32252 x 16-bit	61436 x 16-bit
Data Flash	2K x 16-bit	4K x 16-bit	4K x 16-bit	8K x 16-bit
Program RAM	1K x 16-bit	512 x 16-bit	512 x 16-bit	2K x 16-bit
Data RAM	1K x 16-bit	2K x 16-bit	2K x 16-bit	4K x 16-bit
Boot Flash	2K x 16-bit	2K x 16-bit	2K x 16-bit	2K x 16-bit

## 2.2 56F8346, 56800E Core Family

The 56F8346 provides the following peripheral blocks:

- Two Pulse Width Modulator modules (PWMA and PWMB), each with six PWM outputs, three Current Sense inputs, and three Fault inputs for PWMA/PWMB; fault-tolerant design with dead time insertion, supporting both center-aligned and edge-aligned modes
- Two 12-bit Analog-to-Digital Converters (ADCs), supporting two simultaneous conversions with dual 4-pin multiplexed inputs; the ADC can be synchronized by PWM modules
- Two Quadrature Decoders (Quad Dec0 and Quad Dec1), each with four inputs, or two additional Quad Timers, A and B
- Two dedicated general purpose Quad Timers totaling three pins: Timer C with one pin and Timer D with two pins
- CAN 2.0 B-compatible module with 2-pin ports used to transmit and receive
- Two Serial Communication Interfaces (SCI0 and SCI1), each with two pins, or four additional GPIO lines
- Serial Peripheral Interface (SPI), with configurable 4-pin port, or four additional GPIO lines
- Computer Operating Properly (COP) / Watchdog timer
- Two dedicated external interrupt pins
- 61 multiplexed General Purpose I/O (GPIO) pins
- External reset pin for hardware reset
- JTAG / On-Chip Emulation (OnCE)
- Software-programmable, Phase Lock Loop-based frequency synthesizer for the hybrid controller core clock
- Temperature Sensor system

**Table 2-2 Memory Configuration for 56F8300 Devices**

	<b>56F8322</b>	<b>56F8323</b>	<b>56F8345</b>	<b>56F8346</b>	<b>56F8347</b>
Program Flash	16K x 16-bit	16K x 16-bit	64K x 16-bit	64K x 16-bit	64 x 16-bit
Data Flash	4K x 16-bit	4K x 16-bit	4K x 16-bit	4K x 16-bit	4K x 16-bit
Program RAM	2K x 16-bit	2K x 16-bit	2K x 16-bit	2K x 16-bit	2K x 16-bit
Data RAM	4K x 16-bit	4K x 16-bit	4K x 16-bit	4K x 16-bit	2K x 16-bit
Boot Flash	4K x 16-bit	4K x 16-bit	4K x 16-bit	4K x 16-bit	4K x16-bit

**Table 2-2 Memory Configuration for 56F8300 Devices (Continued)**

	56F8355	56F8356	56F8357	56F8365	56F8366	56F8367
Program Flash	128K x 16-bit	128K x 16-bit	128K x 16-bit	256K x 16-bit	128K x 16-bit	128K x 16-bit
Data Flash	4K x 16-bit	4K x 16-bit	4K x 16-bit	16K x 16-bit	4K x 16-bit	4K x 16-bit
Program RAM	2K x 16-bit	2K x 116-bit	2K x 16-bit	2K x 16-bit	2K x 16-bit	2K x 16-bit
Data RAM	8K x 16-bit	8K x 16-bit	8K x 16-bit	16K x 16-bit	4K x 16-bit	8K x 16-bit
Boot Flash	4K x 16-bit	8K x 16-bit	8K x 16-bit	16K x 16-bit	8K x 16-bit	8K x 16-bit

### 2.3 Peripheral Description

In addition to the fast Analog-to-Digital converter and the 16-bit Quadrature Timers, the most interesting peripheral, for PMSM control, is the Pulse Width Modulation (PWM) unit. The PWM module offers a high degree of freedom in its configuration, allowing efficient control of the PM synchronous motor.

The PWM has the following features:

- Three complementary PWM signal pairs, or six independent PWM signals
- Supports complementary channel operation
- Dead time insertion
- Separate top and bottom pulse width correction via current status inputs or software
- Separate top and bottom polarity control
- Edge-aligned or center-aligned PWM signals
- 15 bits of resolution
- Half-cycle reload capability
- Integral reload rates from 1 to 16
- Individual software-controlled PWM outputs
- Mask and swap of PWM outputs
- Programmable fault protection
- Polarity control
- 20mA current sink capability on PWM pins
- Write-protectable registers

PM synchronous motor control utilizes the PWM block set in the complementary PWM mode, permitting generation of control signals for all switches of the power stage with inserted dead time. The PWM block generates three sinewave outputs mutually shifted by 120 degrees.

The Analog-to-Digital Converter (ADC) consists of a digital control module and two analog Sample and Hold (S/H) circuits. ADC features include:

- 12-bit resolution
- Maximum ADC clock frequency is 5MHz with 200ns period
- Single conversion time of 8.5 ADC clock cycles ( $8.5 \times 200\text{ns} = 1.7\mu\text{s}$ )
- Additional conversion time of 6 ADC clock cycles ( $6 \times 200\text{ns} = 1.2\mu\text{s}$ )
- Eight conversions in 26.5 ADC clock cycles ( $26.5 \times 200\text{ns} = 5.3\mu\text{s}$ ) using simultaneous mode
- ADC can be synchronized to the PWM via the sync signal
- Simultaneous or sequential sampling
- Internal multiplexer to select two of eight inputs
- Ability to sequentially scan and store up to eight measurements
- Ability to simultaneously sample and hold two inputs
- Optional interrupts at end of scan, if an out-of-range limit is exceeded, or at zero crossing
- Optional sample correction by subtracting a preprogrammed offset value
- Signed or unsigned result
- Single-ended or differential inputs

The application utilizes the ADC block in simultaneous mode and sequential scan. It is synchronized with PWM pulses. This configuration allows the simultaneous conversion within the required time of required analog values, all phase currents, voltage and temperature.

The Quad Timer is an extremely flexible module, providing all required services relating to time events, and offers the following features:

- Each timer module consists of four 16-bit counters / timers
- Counts up / down
- Counters are cascadable
- Programmable count modulo
- Maximum count rate equals peripheral clock / 2 when counting external events
- Maximum count rate equals peripheral clock when using internal clocks
- Counts once or repeatedly
- Counters are preloadable
- Counters can share available input pins
- Each counter has a separate prescaler
- Each counter has capture and compare capability

The PMSM vector control application utilizes four channels of the Quad Timer module for position and speed sensing. A fifth channel of the Quad Timer module is set to generate a time base for speed sensing and a speed controller.

The Quadrature Decoder is a module providing decoding of position signals from a Quadrature Encoder mounted on a motor shaft. It has the following features:

- Includes logic to decode quadrature signals
- Configurable digital filter for inputs
- 32-bit position counter
- 16-bit position difference counter
- Maximum count frequency equals the peripheral clock rate
- Position counter can be initialized by software or external events
- Preloadable 16-bit revolution counter
- Inputs can be connected to a general purpose timer to aid low speed velocity

The PM synchronous motor vector control application utilizes the Quadrature Decoder connected to Quad Timer module B. It uses the decoder's digital input filter to filter the encoder's signals, but does not make use of its decoding functions, freeing the decoder's digital processing capabilities to be used by another application.

## 3. Target Motor Theory

### 3.1 Permanent Magnet Synchronous Motor (PMSM)

The PMSM is a rotating electric machine with a classic 3-phase stator like that of an induction motor; the rotor has surface-mounted permanent magnets; see [Figure 3-1](#).

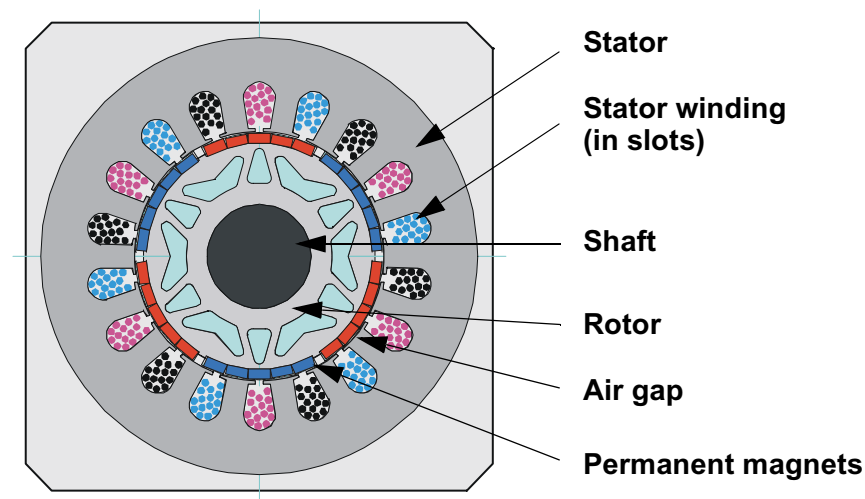

**Figure 3-1 Cross Section of a PM Synchronous Motor**

In this respect, the PMSM is equivalent to an induction motor, where the air gap magnetic field is produced by a permanent magnet, so the rotor magnetic field is constant. PM synchronous motors offer a number of advantages in designing modern motion control systems. The use of a permanent magnet to generate substantial air gap magnetic flux makes it possible to design highly efficient PM motors.

## 3.2 Mathematical Description of PM Synchronous Motor

The model used for vector control design can be understood by using space vector theory. The 3-phase motor quantities (such as voltages, currents, magnetic flux, etc.) are expressed in terms of complex space vectors. Such a model is valid for any instantaneous variation of voltage and current and adequately describes the performance of the machine under both steady-state and transient operation. The complex space vectors can be described using only two orthogonal axes. The motor can be considered a 2-phase machine. Using a 2-phase motor model reduces the number of equations and simplifies the control design.

### 3.2.1 Space Vector Definition

Assume  $i_{sa}$ ,  $i_{sb}$ ,  $i_{sc}$  are the instantaneous balanced three-phase stator currents:

$$i_{sa} + i_{sb} + i_{sc} = 0 \quad \text{EQ. 3-1}$$

It is then possible to define the stator current space vector as follows:

$$\bar{i}_s = k(i_{sa} + ai_{sb} + a^2i_{sc}) \quad \text{EQ. 3-2}$$

Where:

- $a$  and  $a^2$  = The spatial operators
- $a$  =  $e^{j2\pi/3}$
- $a^2$  =  $e^{j4\pi/3}$
- $k$  = The transformation constant, chosen as  $k=2/3$

**Figure 3-2** shows the stator current space vector projection:

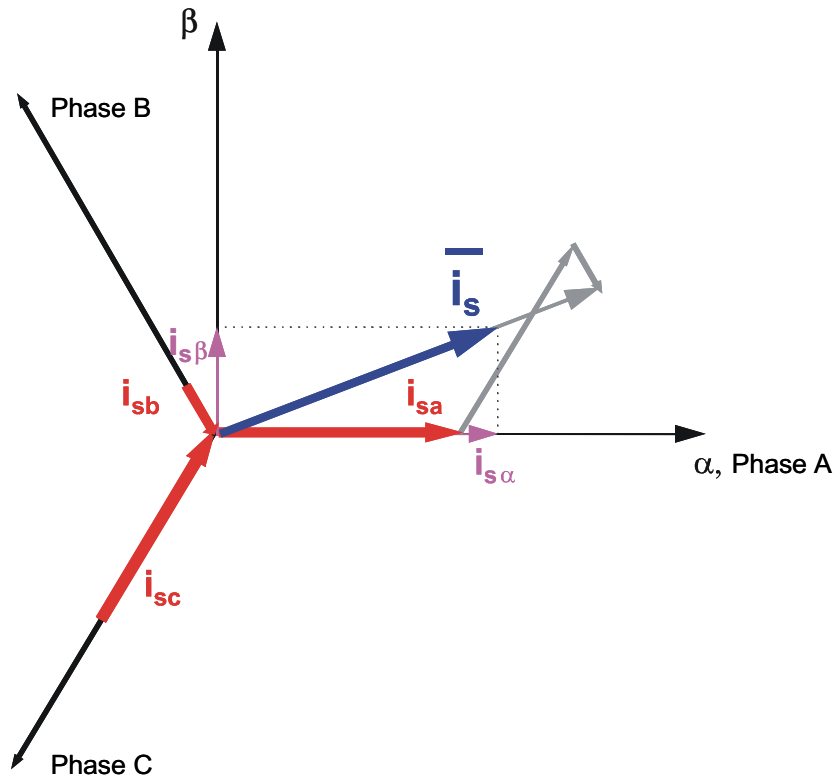

**Figure 3-2 Stator Current Space Vector and Its Projection**

The space vector defined by [EQ. 3-2](#) can be expressed utilizing two-axis theory. The real part of the space vector is equal to the instantaneous value of the direct-axis stator current component,  $i_{s\alpha}$ , and whose imaginary part is equal to the quadrature-axis stator current component,  $i_{s\beta}$ . Thus, the stator current space vector, in the stationary reference frame attached to the stator, can be expressed as:

$$\bar{i}_s = i_{s\alpha} + j i_{s\beta} \quad \text{EQ. 3-3}$$

In symmetrical 3-phase machines, the direct and quadrature axis stator currents  $i_{s\alpha}$  and  $i_{s\beta}$  are fictitious quadrature-phase (2-phase) current components, which are related to the actual 3-phase stator currents as follows:

$$i_{s\alpha} = k \left( i_{sa} - \frac{1}{2} i_{sb} - \frac{1}{2} i_{sc} \right) \quad \text{EQ. 3-4}$$

$$i_{s\beta} = k \frac{\sqrt{3}}{2} (i_{sb} - i_{sc}) \quad \text{EQ. 3-5}$$

Where:

$$k = \frac{2}{3} \text{ is a transformation constant}$$



The space vectors of other motor quantities (voltages, currents, magnetic fluxes, etc.) can be defined in the same way as the stator current space vector.

For a description of the PM synchronous motor, consider the symmetrical 3-phase smooth-air-gap machine with sinusoidally-distributed windings. The voltage equations of stator in the instantaneous form can then be expressed as:

$$u_{SA} = R_S i_{SA} + \frac{d}{dt} \Psi_{SA} \quad \text{EQ. 3-6}$$

$$u_{SB} = R_S i_{SB} + \frac{d}{dt} \Psi_{SB} \quad \text{EQ. 3-7}$$

$$u_{SC} = R_S i_{SC} + \frac{d}{dt} \Psi_{SC} \quad \text{EQ. 3-8}$$

Where:

- $u_{SA}, u_{SB}$  and  $u_{SC}$  = The instantaneous values of stator voltages in phase SA, SB and SC
- $i_{SA}, i_{SB}$  and  $i_{SC}$  = The instantaneous values of stator currents in phase SA, SB and SC
- $\Psi_{SA}, \Psi_{SB}, \Psi_{SC}$  = The instantaneous values of stator flux linkages in phase SA, SB and SC

Due to the large number of equations in the instantaneous form, including [EQ. 3-6](#), [EQ. 3-7](#) and [EQ. 3-8](#), it is more practical to rewrite the instantaneous equations using the two-axis theory (Clarke transformation). The PM synchronous motor can be expressed as:

$$u_{S\alpha} = R_S i_{S\alpha} + \frac{d}{dt} \Psi_{S\alpha} \quad \text{EQ. 3-9}$$

$$u_{S\beta} = R_S i_{S\beta} + \frac{d}{dt} \Psi_{S\beta} \quad \text{EQ. 3-10}$$

$$\Psi_{S\alpha} = L_S i_{S\alpha} + \Psi_M \cos(\Theta_r) \quad \text{EQ. 3-11}$$

$$\Psi_{S\beta} = L_S i_{S\beta} + \Psi_M \sin(\Theta_r) \quad \text{EQ. 3-12}$$

$$\frac{d\omega}{dt} = \frac{p}{J} \left[ \frac{3}{2} p (\Psi_{S\alpha} i_{S\beta} - \Psi_{S\beta} i_{S\alpha}) - T_L \right] \quad \text{EQ. 3-13}$$

Where:

- $\alpha, \beta$  = The stator orthogonal coordinate system
- $u_{S\alpha, \beta}$  = The stator voltage
- $i_{S\alpha, \beta}$  = The stator current
- $\Psi_{S\alpha, \beta}$  = The stator magnetic flux
- $\Psi_M$  = The rotor magnetic flux
- $R_S$  = The stator phase resistance

- $L_S$  = The stator phase inductance  
 $\omega / \omega_F$  = The electrical rotor speed / fields speed  
 $p$  = The number of poles per phase  
 $J$  = The inertia  
 $T_L$  = The load torque  
 $\Theta_r$  = The rotor position in  $\alpha, \beta$  coordinate system

EQ. 3-9 through EQ. 3-13 represent the model of PMSM in the stationary frame  $\alpha, \beta$  fixed to the stator.

Besides the stationary reference frame attached to the stator, motor model voltage space vector equations can be formulated in a general reference frame which rotates at a general speed  $\omega_g$ . If a general reference frame is used, with direct and quadrature axes  $x, y$  rotating at a general instantaneous speed,  $\omega_g = d\theta_g/dt$ , as shown in Figure 3-3, where  $\theta_g$  is the angle between the direct axis of the stationary reference frame ( $\alpha$ ) attached to the stator and the real axis ( $x$ ) of the general reference frame, then EQ. 3-14 defines the stator current space vector in general reference frame:

$$\overline{i_{sg}} = \overline{i_s} e^{-j\theta_g} = i_{sx} + j i_{sy} \quad \text{EQ. 3-14}$$

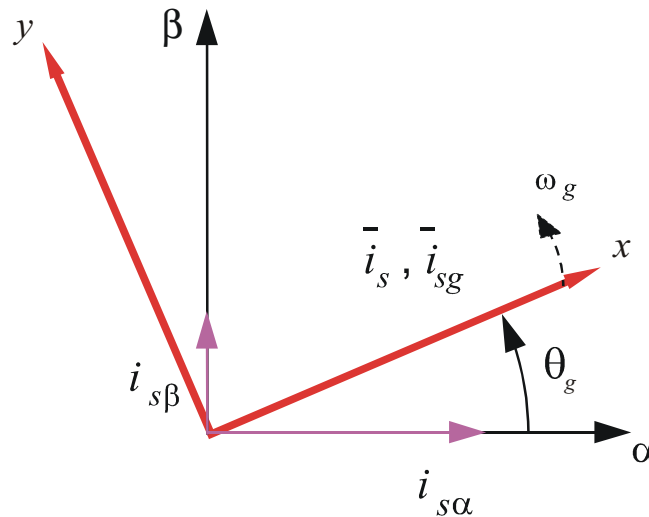

Figure 3-3 Application of the General Reference Frame

The stator voltage and flux-linkage space vectors can be similarly obtained in the general reference frame.

Similar considerations hold for the space vectors of the rotor voltages, currents and flux linkages. The real axis ( $r\alpha$ ) of the reference frame attached to the rotor is displaced from the direct axis of the stator reference frame by the rotor angle,  $\theta_r$ . Since it can be seen that the angle between the real axis ( $x$ ) of the general reference frame and the real axis of the reference frame rotating with the rotor ( $r\alpha$ ) is  $\theta_g - \theta_r$  in the general reference frame, the space vector of the rotor currents can be expressed as:

$$\overline{i_{rg}} = \overline{i_r} e^{-j(\theta_g - \theta_r)} = i_{rx} + j i_{ry} \quad \text{EQ. 3-15}$$

Where:

$\bar{i}_r$  = The space vector of the rotor current in the rotor reference frame

The space vectors of the rotor voltages and rotor flux linkages in the general reference frame can be similarly expressed.

The motor model voltage equations in the general reference frame can be expressed by utilizing introduced transformations of the motor quantities from one reference frame to the general reference frame. The PMSM model is often used in vector control algorithms. The aim of vector control is to implement control schemes which produce high dynamic performance and are similar to those used to control DC machines. To achieve this, the reference frames may be aligned with the stator flux-linkage space vector, the rotor flux-linkage space vector or the magnetizing space vector. The most popular reference frame is the reference frame attached to the rotor flux linkage space vector, with direct axis ( $d$ ) and quadrature axis ( $q$ ).

After transformation into  $d$ - $q$  coordinates, the motor model as follows:

$$u_{Sd} = R_S i_{Sd} + \frac{d}{dt} \Psi_{Sd} - \omega_F \Psi_{Sq} \quad \text{EQ. 3-16}$$

$$u_{Sq} = R_S i_{Sq} + \frac{d}{dt} \Psi_{Sq} + \omega_F \Psi_{Sd} \quad \text{EQ. 3-17}$$

$$\Psi_{Sd} = L_S i_{Sd} + \Psi_M \quad \text{EQ. 3-18}$$

$$\Psi_{Sq} = L_S i_{Sq} \quad \text{EQ. 3-19}$$

$$\frac{d\omega}{dt} = \frac{p}{J} \left[ \frac{3}{2} p (\Psi_{Sd} i_{Sq} - \Psi_{Sq} i_{Sd}) - T_L \right] \quad \text{EQ. 3-20}$$

Below base speed  $i_{sd}=0$ , **EQ. 3-20** can be reduced to the following form:

$$\frac{d\omega}{dt} = \frac{p}{J} \left[ \frac{3}{2} p (\Psi_M i_{Sq}) - T_L \right] \quad \text{EQ. 3-21}$$

From **EQ. 3-21**, it can be seen that the torque is dependent and can be directly controlled by the current  $i_{sq}$  only.

### 3.3 Digital Control of PM Synchronous Motor

In adjustable-speed applications, the PM synchronous motors are powered by inverters. The inverter converts DC power to AC power at the required frequency and amplitude. A typical 3-phase inverter is illustrated in **Figure 3-4**.

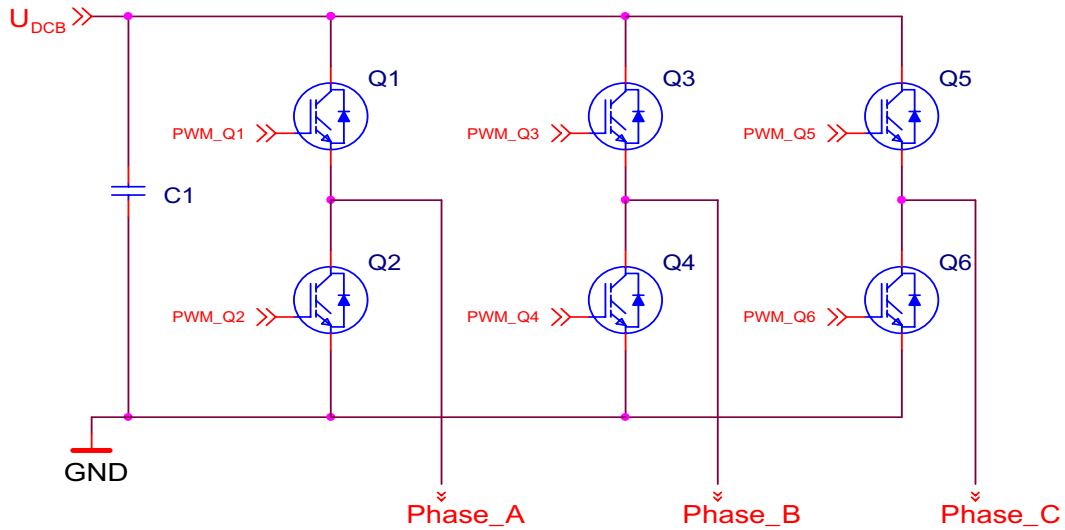

**Figure 3-4 3- Phase Inverter**

The inverter consists of three half-bridge units where the upper and lower switches are controlled complementarily, meaning when the upper one is turned on, the lower one must be turned off, and vice versa. Because the power device’s turn-off time is longer than its turn-on time, some dead time must be inserted between turning off one transistor of the half-bridge, and turning on its complementary device. The output voltage is mostly created by a Pulse Width Modulation (PWM) technique, where an isosceles triangle carrier wave is compared with a fundamental-frequency sine modulating wave, and the natural points of intersection determine the switching points of the power devices of a half-bridge inverter. This technique is shown in **Figure 3-5**. The 3-phase voltage waves are shifted 120° to one another and, thus, a 3-phase motor can be supplied.

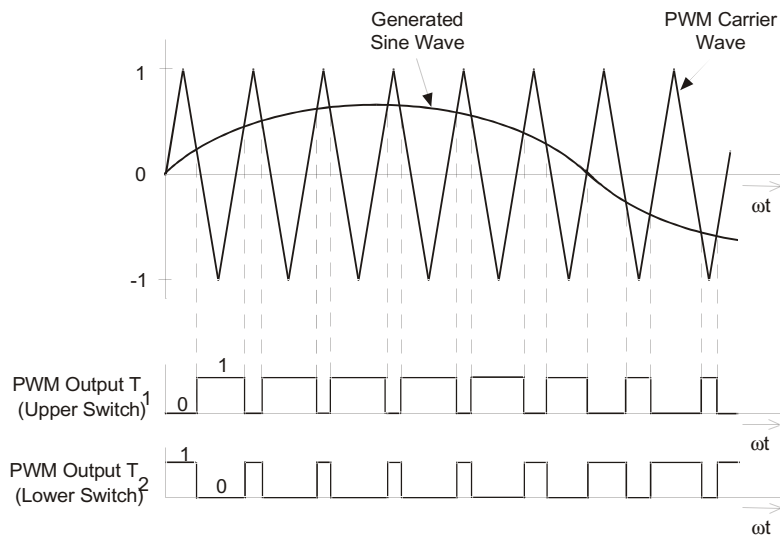

**Figure 3-5 Pulse Width Modulation**

The most popular power devices for motor control applications are Power MOSFETs and IGBTs.

A Power MOSFET is a voltage-controlled transistor. It is designed for high-frequency operation and has a low voltage drop; thus, it has low power losses. However, the saturation temperature sensitivity limits the MOSFET application in high-power applications.

An Insulated-Gate Bipolar Transistor (IGBT) is a bipolar transistor controlled by a MOSFET on its base. The IGBT requires low drive current, has fast switching time, and is suitable for high switching frequencies. The disadvantage is the higher voltage drop of a bipolar transistor, which causes higher conduction losses.

### 3.3.1 Vector Control of PM Synchronous Motor

Vector control is an elegant method to control a PMSM, where field-oriented theory is used to control space vectors of magnetic flux, current, and voltage. It is possible to set up the coordinate system to decompose the vectors into a magnetic field-generating part and a torque-generating part. The structure of the motor controller (Vector Control Controller) is then almost the same as for a separately-excited DC motor, which simplifies the control of a PMSM. This vector control technique was developed specifically to achieve a similarly dynamic performance in PM synchronous motors.

As explained in [Section 4.2](#), a widely used speed control with inner current closed-loop was chosen, where the rotor flux is controlled by a field-weakening controller.

In this method, the field-generating and torque-generating parts of the stator current must be broken down in order to be able to separately control the magnetic flux and the torque. In accomplish this, it's necessary to set up the rotary coordinate system connected to the rotor magnetic field; this system is generally called a “d-q coordinate system”. Very high CPU performance is needed to perform the transformation from rotary to stationary coordinate systems. Therefore, Freescale's 56F80x or 56F8300 devices are very well suited for use in a vector control algorithm. All transformations needed for Vector Control will be described in the next section.

### 3.3.2 Block Diagram of Vector Control

[Figure 3-6](#) shows the basic structure of PMSM vector control. To perform vector control, follow these steps:

- Measure the motor quantities (phase voltages and currents)
- Transform the quantities into a 2-phase system ( $\alpha, \beta$ ), using Clarke transformation
- Calculate the rotor flux space vector magnitude and position angle
- Transform stator currents into the d-q coordinate system using Park transformation
- The stator current torque- ( $i_{sq}$ ) and flux- ( $i_{sd}$ ) producing components are separately controlled by the controllers
- The output stator voltage space vector is calculated using the decoupling block
- The stator voltage space vector is transformed back from the d-q coordinate system into the two-phase system and fixed with the stator by inverse Park transformation
- Using sinewave modulation, the output 3-phase voltage is generated

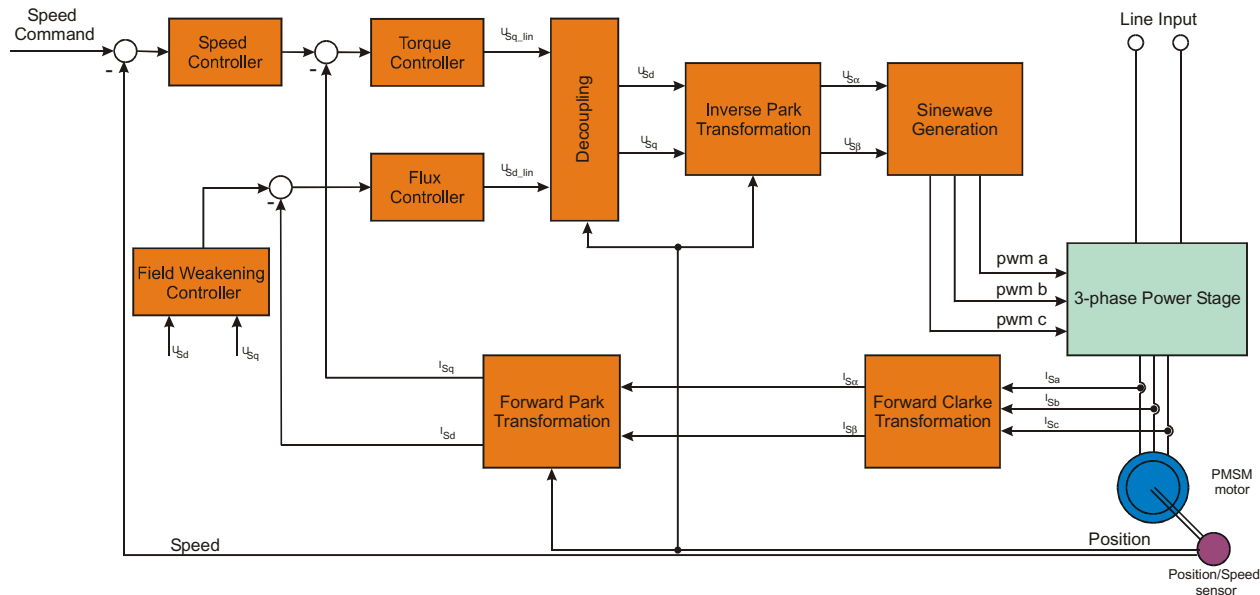

**Figure 3-6 Block Diagram of PM Synchronous Motor Vector Control**

### 3.3.3 Vector Control Transformations

Transforming a PMSM into a DC motor is based on selection of coordinates. As shown in [Section 3.3.2](#), a coordinate transformation is required.

The following transformations are involved in vector control:

- Transformations from a 3-phase to a 2-phase system (Clarke transformation)
- Rotation of orthogonal system
  - $\alpha, \beta$  to d-q (Park transformation)
  - d-q to  $\alpha, \beta$  (Inverse Park transformation)

#### 3.3.3.1 Clarke Transformation

[Figure 3-7](#) shows how a 3-phase system is transformed into a 2-phase system.

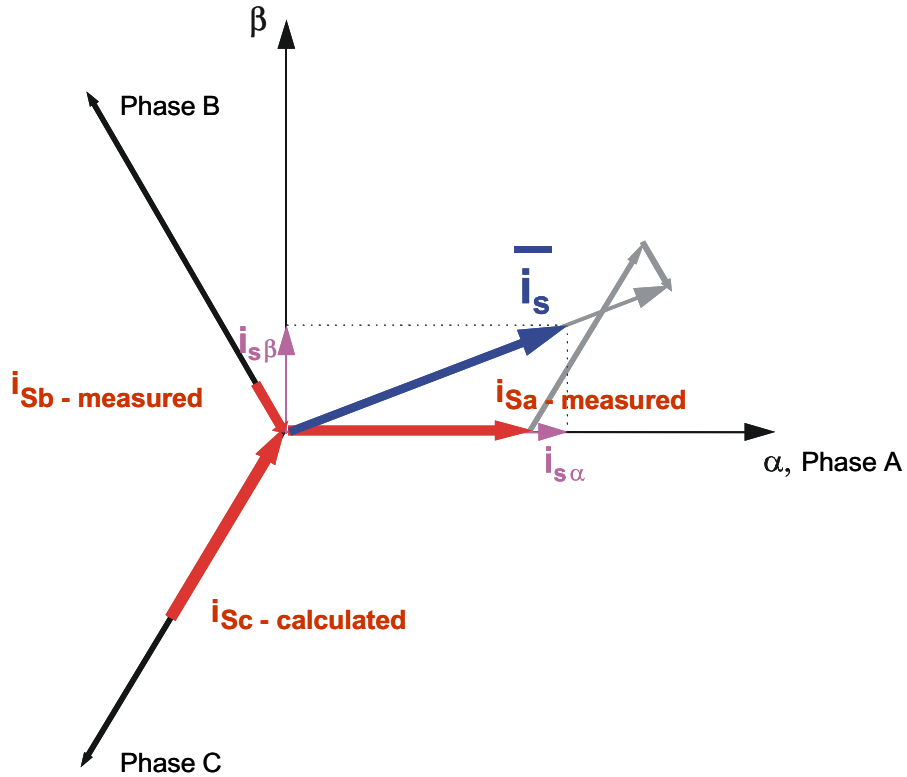

**Figure 3-7 Clarke Transformation**

To transfer the graphical representation into mathematical language:

$$\begin{bmatrix} \alpha \\ \beta \end{bmatrix} = K \begin{bmatrix} 1 & -\frac{1}{2} & -\frac{1}{2} \\ 0 & \frac{\sqrt{3}}{2} & -\frac{\sqrt{3}}{2} \end{bmatrix} \begin{bmatrix} a \\ b \\ c \end{bmatrix} \quad \text{EQ. 3-22}$$

In most cases, the 3-phase system is symmetrical, which means that the sum of the phase quantities is always zero.

$$\alpha = K \left( a - \frac{1}{2}b - \frac{1}{2}c \right) = | a + b + c = 0 | = K \frac{3}{2}a \quad \text{EQ. 3-23}$$

The constant “K” can be freely chosen; equalizing the  $\alpha$ -quantity and Phase A quantity is recommended. Then:

$$\alpha = a \Rightarrow K = \frac{2}{3} \quad \text{EQ. 3-24}$$

**EQ. 3-25** fully defines the Park-Clarke transformation:

$$\begin{bmatrix} \alpha \\ \beta \end{bmatrix} = \begin{bmatrix} \frac{2}{3} & -\frac{1}{3} & -\frac{1}{3} \\ 0 & \frac{1}{\sqrt{3}} & -\frac{1}{\sqrt{3}} \end{bmatrix} \begin{bmatrix} a \\ b \\ c \end{bmatrix} = \left| \begin{array}{c} a+b+c=0 \\ \end{array} \right| = \begin{bmatrix} 1 & 0 & 0 \\ 0 & \frac{1}{\sqrt{3}} & -\frac{1}{\sqrt{3}} \end{bmatrix} \begin{bmatrix} a \\ b \\ c \end{bmatrix} \quad \text{EQ. 3-25}$$

### 3.3.3.2 Transformation from $\alpha$ , $\beta$ to d-q Coordinates and Backwards

Vector control is performed entirely in the d-q coordinate system to make the control of PM synchronous motors elegant and easy; see [Section 3.3.2](#).

This process requires transformation in both directions and the control action must be transformed back to the motor side.

First, establish the d-q coordinate system:

$$\Psi_M = \sqrt{\Psi_{M\alpha}^2 + \Psi_{M\beta}^2} \quad \text{EQ. 3-26}$$

$$\sin \vartheta_{Field} = \frac{\Psi_{M\beta}}{\Psi_{Md}} \quad \text{EQ. 3-27}$$

$$\cos \vartheta_{Field} = \frac{\Psi_{M\alpha}}{\Psi_{Md}}$$

Then transform from  $\alpha$ ,  $\beta$  to d-q coordinates:

$$\begin{bmatrix} d \\ q \end{bmatrix} = \begin{bmatrix} \cos \vartheta_{Field} & \sin \vartheta_{Field} \\ -\sin \vartheta_{Field} & \cos \vartheta_{Field} \end{bmatrix} \begin{bmatrix} \alpha \\ \beta \end{bmatrix} \quad \text{EQ. 3-28}$$

**Figure 3-8** illustrates this transformation.



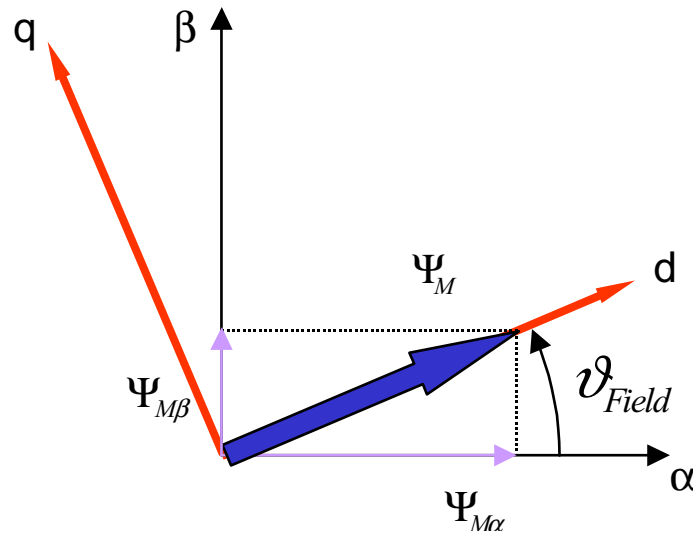

**Figure 3-8 Establishing the d-q Coordinate System (Park Transformation)**

The backward (Inverse Park) transformation (from d-q to  $\alpha$ ,  $\beta$ ) is:

$$\begin{bmatrix} \alpha \\ \beta \end{bmatrix} = \begin{bmatrix} \cos \vartheta_{Field} & -\sin \vartheta_{Field} \\ \sin \vartheta_{Field} & \cos \vartheta_{Field} \end{bmatrix} \begin{bmatrix} d \\ q \end{bmatrix} \quad \text{EQ. 3-29}$$

### 3.3.4 PMSM Vector Control and Field-Weakening Controller

This section describes the control regarding the required stator current vectors  $i_{sd}$ ,  $i_{sq}$ .

There are two speed ranges (shown in **Figure 3-9**), which differ by controlled current vector:

- Control in Normal Operating Range, control mode used when a speed is required below nominal motor speed
- Control in Field-Weakening Range, control mode used when a speed is required above nominal motor speed

#### 3.3.4.1 Control in Normal Operating Range

Assume an ideal PMSM with constant stator reluctance:  $L_s = \text{constant}$ . **EQ. 3-17**, **EQ. 3-18** and **EQ. 3-19** can then be written as:

$$u_{Sq} = R_S i_{Sq} + L_S \frac{d}{dt} i_{Sq} + \omega_F (L_S i_{Sd} + \Psi_M) \quad \text{EQ. 3-30}$$

As demonstrated from the PMSM equations, the maximum efficiency of the ideal PMSM is obtained when maintaining the current flux-producing component,  $i_{sd}$ , at zero. Therefore, in the drive from **Figure 3-6**, the Field-Weakening Controller sets  $i_{sd} = 0$  in the normal operating range. The speed regulator controls the current torque-producing component,  $i_{sq}$ .

A real 3-phase power inverter has voltage and current rating limitations:

1. The absolute value of stator voltage  $u_s$  is physically limited according to DCBus voltage to a limit of  $u_{sdq\_max}$
2. The absolute value of the stator current  $i_s$  should be maintained below a limit of  $I_{SDQ\_MAX}$ , given by the maximum current rating

In the normal operating range, the current torque-producing component,  $i_{sq}$ , can be set up to  $I_{SDQ\_MAX}$ , since  $i_{sd} = 0$ .

Due to the voltage limitation, the maximum speed in the normal motor operating range is limited for  $i_{sd} = 0$ , to a nominal motor speed, as shown in **Figure 3-9** and **EQ. 3-30**.

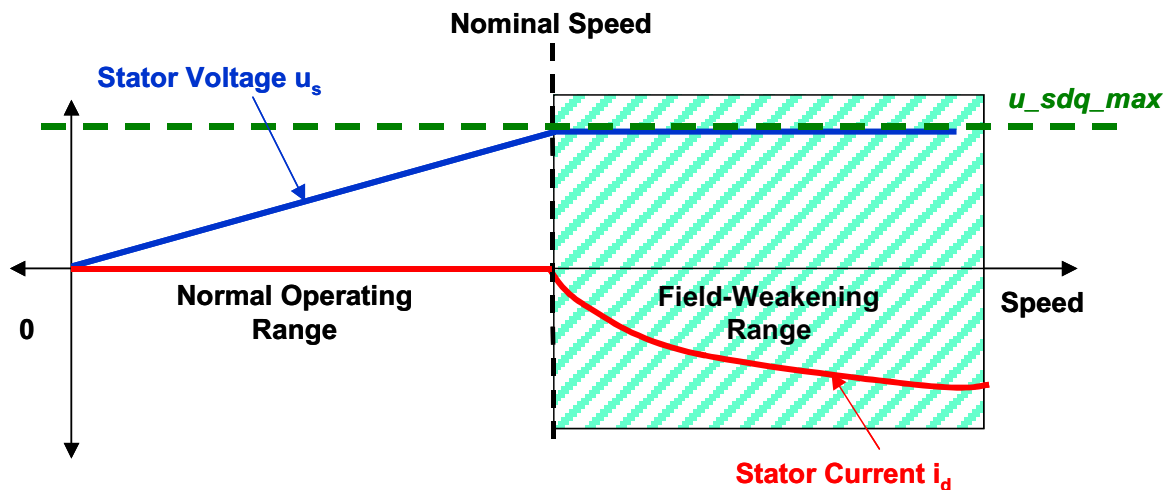

**Figure 3-9 Normal Operation and Field-Weakening**

### 3.3.4.2 Control in Field-Weakening Range

The field-weakening technique must be used where a higher maximum motor speed is required, which is provided by maintaining the flux-producing current component,  $i_{sd}$ , in the field-weakening range, as shown in **Figure 3-9**.

Due to the limitation of absolute current value, the current torque-producing component,  $i_{sq}$ , must be maintained below a limited value.

$$i_{sq} < \sqrt{I_{SDQ\_MAX}^2 - i_{sd}^2} \quad \text{EQ. 3-31}$$

One possibility to maintain the flux-producing current component,  $i_{sd}$ , for field weakening is to use a look-up table.

A more-progressive method uses a Field-Weakening Controller, which generates a negative current flux-producing component,  $i_{sq}$ , whenever the absolute value of stator voltage exceeds  $u_{S\_max\_FWLimit}$ . The field-weakening limit,  $u_{S\_max\_FWLimit}$ , is set to be close to the maximum voltage limit of the 3-phase power inverter,  $u_{sdq\_max}$ , with some reserve for regulation. Since the DCBus voltage determines the

$u_{sdq\_max}$  limit, the  $u_{S\_max\_FWLimit}$  is set according to the DCBus. The  $u_{S\_max\_FWLimit}$  can be a constant or it can be calculated from a measured DCBus voltage. The Field-Weakening controller is described in [Section 6.2.5.4](#).

## 4. System Concept

### 4.1 System Specification

The motor control system is designed to drive a 3-phase PM Synchronous Motor (PMSM) in a speed closed-loop. The application meets the following performance specifications:

- Vector control of PMSM using the Quadrature Encoder as a position sensor
- Targeted for a 56F80xEVM or 56F83xxEVM plus Legacy Motor Daughter Card (LMDC)
- Runs on a 3-phase PMSM control development platform at a variable line voltage, 110 - 230V AC
- Control technique incorporates:
  - Vector control with speed closed-loop and field-weakening
  - Rotation in both directions
  - Motoring and generator mode with brake
  - Start from any motor position with rotor alignment
  - Minimum speed of **50rpm**
  - Maximum speed of **3000rpm** at input power line 230V AC
  - Maximum speed of **1500rpm** at input power line 115V AC
- Manual interface
  - RUN / STOP switch
  - UP / DOWN push button control
  - LED indicator)
- PC master software control interface
  - Motor start / stop
  - Speed set-up
- PC master software remote monitor
- Power stage board identification
- Fault protection against:
  - Overvoltage
  - Undervoltage
  - Overcurrent
  - Overheating

The PM synchronous drive introduced here is designed to power a high-voltage PM synchronous motor with a Quadrature Encoder. Specifications are detailed in [Table 4-1](#).

**Table 4-1 High Voltage Hardware Set Specifications**

Motor Characteristics	Motor Type	Six poles, 3-phase, star connected, BLDC motor
	Speed Range	2500rpm (at 310V DCBus)
	Maximum Electrical Power	150W
	Phase Voltage	3*220V
	Phase Current	0.55A
Drive Characteristics	Speed Range	< 3000rpm
	Input Voltage	310V DC
	Maximum DCBus Voltage	380V
	Control Algorithm	Speed Closed-Loop Control
	Optoisolation	Required

## 4.2 Vector Control Drive Concept

A standard system concept is used with this drive; see [Figure 4-1](#). The system incorporates the following hardware parts:

- Three-phase PMSM high-voltage development platform
- Feedback sensors for:
  - Position (Quadrature Encoder)
  - DCBus voltage
  - Phase currents
  - DCBus overcurrent detection
  - Temperature
- Evaluation Modules:
  - 56F80xEVM (56800 Core)
  - 56F83xxEVM (56800E Core)

The drive can be controlled in two operating modes:

- In the **Manual** operating mode, the required speed is set by the RUN / STOP switch and the UP/DOWN push buttons
- In the **PC master software** operating mode, the required speed and RUN / STOP switch are set by the PC

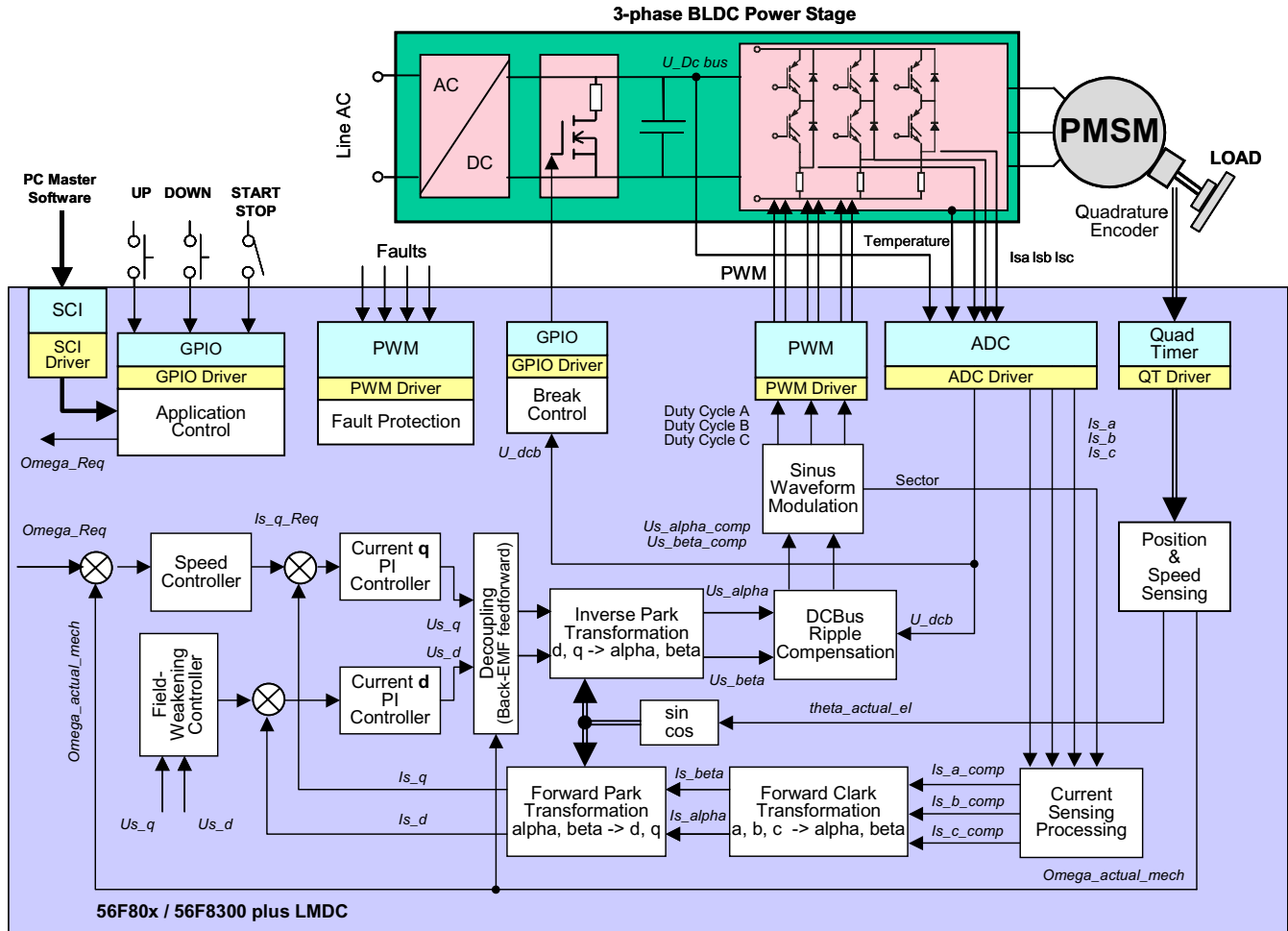

Figure 4-1 Drive Concept

The control process follows:

When the Start command is accepted (using the RUN / STOP Switch or PC master software command), the required speed is calculated according to the UP / DOWN push buttons or PC master software commands. The required speed proceeds through an acceleration / deceleration ramp, and a reference command is put to the speed controller. The actual speed is calculated from the pulses of the Quadrature Encoder. The comparison between the required speed command and the actual measured speed generates a speed error. Based on the error, the speed controller generates a current,  $I_{s\_qReq}$ , which corresponds to torque. A second part of stator current  $I_{s\_dReq}$ , which corresponds to flux, is given by the Field-Weakening Controller. Simultaneously, the stator currents  $I_{s\_a}$ ,  $I_{s\_b}$ , and  $I_{s\_c}$  are measured and transformed from instantaneous values into the stationary reference frame  $\alpha$ ,  $\beta$ , and consecutively into the rotary reference frame d-q (Park - Clarke transformation). Based on the errors between required and actual currents in the rotary reference frame, the current controllers generate output voltages  $U_{s\_q}$  and  $U_{s\_d}$  (in the rotary reference frame d-q). The voltages  $U_{s\_q}$  and  $U_{s\_d}$  are transformed back into the stationary reference frame  $\alpha$ ,  $\beta$  and, after DCBus ripple elimination, are recalculated to the 3-phase voltage system, which is applied to the motor.

In addition to the main control loop, the DCBus voltage, DCBus current and power stage temperature are measured during the control process. They are used to protect the drive from overvoltage, undervoltage, overcurrent and overheating. Undervoltage and overheating protection is performed by software, while the overcurrent and overvoltage fault signals utilize a fault input of the hybrid controller.

If any of the previously mentioned faults occur, the motor control PWM outputs are disabled in order to protect the drive, and the fault state of the system is displayed by the on-board LED.

### 4.3 System Blocks Concept

This section explains the system block concept for targeting the 56F83xxEVM.

#### 4.3.1 Position and Speed Sensing

All members of Freescale's 56F8300 family have a Quadrature Decoder. This peripheral is commonly used for position and speed sensing. The Quadrature Decoder position counter counts each edge of Phase A and Phase B signals up or down according to its order. On each revolution, the position counter is cleared by an index pulse; see [Figure 4-2](#).

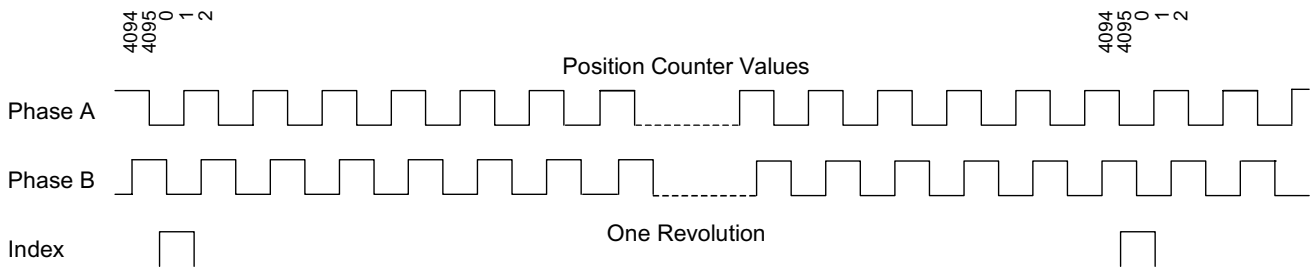

**Figure 4-2 Quadrature Encoder Signals**

Because the position counter is cleared on each revolution by an index pulse, the zero position is linked with the index pulse, but vector control requires the zero position, where the rotor is aligned to the  $d$  axis; see [Section 4.3.1.3](#). Therefore, using a Quadrature Decoder to decode the encoder's signal requires either the calculation of an offset which aligns the Quadrature Decoder position counter with the aligned rotor position (zero position), or the coupling of the zero rotor position with the index pulse of a Quadrature Encoder. To avoid the calculation of the rotor position offset, the Quadrature Decoder is not used in this application. The decoder's digital processing capabilities are then free to be used by another application.

In addition to the Quadrature Decoder, the input signals (Phase A, Phase B and Index) are connected to Quad Timer B. The Quad Timer module consists of four Quad Timers. Due to the wide variability of Quad Timer modules, it is possible to use this module to decode Quadrature Encoder signals, sense position, and speed. A configuration of the Quad Timer module is shown in [Figure 4-3](#).

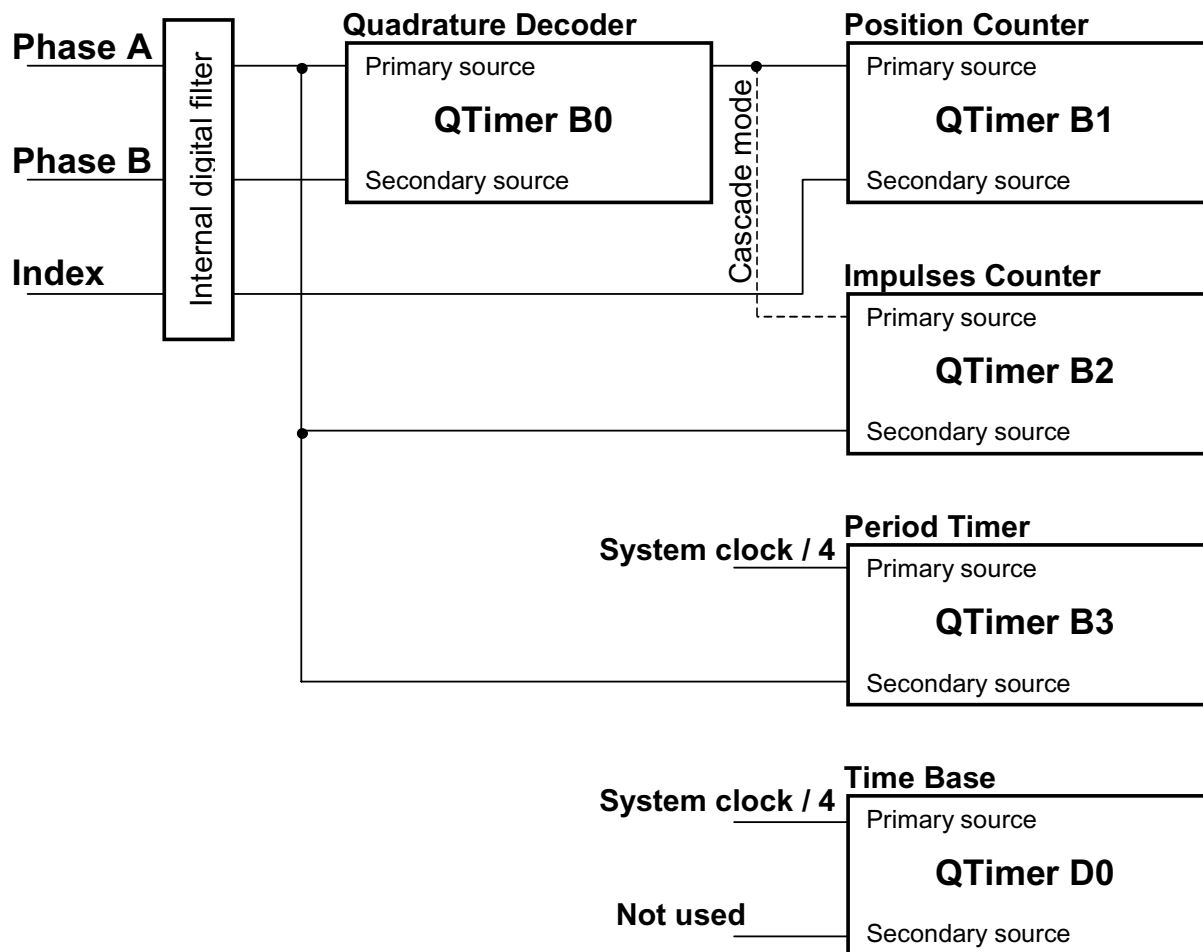

Figure 4-3 Quad Timer B Configuration

#### 4.3.1.1 Position Sensing

The position and speed sensing algorithm uses all of the timers in module B and an additional timer as a time base. Timers B0 and B1 are used for position sensing. Timer B0 permits connection of three input signals to the Quad Timer B1, even if Timer B1 has only two inputs (primary and secondary), accomplished by using Timer B0 as a Quadrature Decoder only. It is set to count in the quadrature mode, count to zero, and then reinitialize. This timer setting is used to decode quadrature signals only. Timer B1 is connected to Timer B0 in cascade mode, in which the information about counting up or down is connected internally to Timer B1, freeing the secondary input of Timer B1 to be used for the index pulse. Counter B1 is set to count to  $\pm((4 \times \text{number of pulses per revolution}) - 1)$  and reinitialize after compare. The value of Timer B1 corresponds to the rotor position.

The position of the index pulse is sensed to avoid the loss of some pulses under the influence of noise during extended motor operation, which can result in incorrect rotor position sensing. If some pulses are lost, a different position of the index pulse is detected, and a position sensing error is signaled. If a check of the index pulse is not required, Timer B1 can be removed and Timer B0 set as the position counter B1. The resulting value of Timer B1 is scaled to range  $[-1; 1)$ , which corresponds to  $[-\pi; \pi)$ .

#### 4.3.1.2 Speed Sensing

There are two common ways to measure speed. The first method measures the time between two following edges of the Quadrature Encoder, and the second method measures a position difference (a number of pulses) per constant period. The first method is used at low speed. When the measured period is so short that the speed calculation is not precise, the speed calculation algorithm switches to the second method.

The proposed algorithm combines both methods. The algorithm simultaneously measures the number of Quadrature Encoder pulses per constant period, and an accurate time interval between the first and last pulse is counted during that constant period. The speed can then be expressed as:

$$speed = \frac{k \cdot N}{T} \quad \text{EQ. 4-1}$$

where:

<i>speed</i>	=	Calculated speed
<i>k</i>	=	Scaling constant
<i>N</i>	=	Number of pulses per constant period
<i>T</i>	=	Accurate period of <i>N</i> pulses

The algorithm requires two timers for counting pulses and measuring their period, and a third timer as a time base; see [Figure 4-3](#). Timer B2 counts the pulses of the Quadrature Encoder, and Timer B3 counts a system clock divided by 4 (system clock / 4). The values in both timers can be captured by each edge of the Phase A signal. The time base is provided by timer D0, which is set to call the speed processing algorithm every 900µs. An explanation of how the speed processing algorithm works follows.

First, the new captured values of both timers are read. The difference in the number of pulses and their accurate time interval are calculated from actual and previous values. The new values are then saved for the next period, and the capture register is enabled. From that moment, the first edge of Phase A signal captures the values of both Timer B2 and Timer B3, and the capture register is disabled. This process is repeated on each call of the speed processing algorithm; see [Figure 4-4](#).



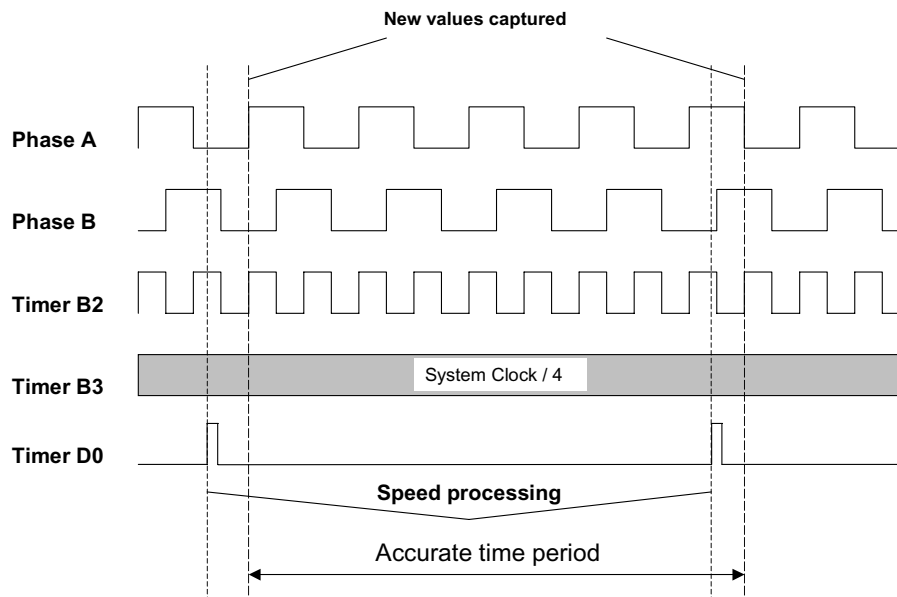

**Figure 4-4 Speed Processing**

#### 4.3.1.2.1 Minimum and Maximum Speed Calculation

The minimum speed is calculated with the following equation:

$$\omega_{min} = \frac{60}{4NT_{calc}} \quad \text{EQ. 4-2}$$

Where:

- $\omega_{min}$  = Minimum obtainable speed [rpm]
- $N$  = Number of pulses per revolution [1 / rev]
- $T_{calc}$  = Period of speed measurement (calculation period) [s]

In the application, the Quadrature Encoder has 1024 pulses per revolution and a calculation period of 900 $\mu$ s was chosen on the basis of a motor mechanical constant. Thus, [EQ. 4-2](#) calculates the minimum speed as 16.3rpm.

The maximum speed can be expressed as:

$$\omega_{max} = \frac{60}{4NT_{clkT3}} \quad \text{EQ. 4-3}$$

Where:

- $\omega_{max}$  = Maximum obtainable speed [rpm]
- $N$  = Number of pulses per revolution [1 / rev]
- $T_{clkT3}$  = Period of input clock to Timer B3 [s]

Substitution in **EQ. 4-3** for  $N$  and  $T_{clkT3}$  (Timer B3 input clock = system clock 30MHz / 2) yields a maximum speed of 219726rpm. As demonstrated, the algorithm can measure speed across a wide range. Because such high speed is not practical, the maximum speed can be reduced to a required range by the constant  $k$  in **EQ. 4-1**. The constant  $k$  can be calculated as:

$$k = \frac{60}{4NT_{clkT3}\omega_{max}} \quad \text{EQ. 4-4}$$

Where:

- $k$  = Scaling constant in **EQ. 4-1**
- $\omega_{max}$  = Maximum of the speed range [rpm]
- $N$  = Number of pulses per revolution [1 / rev]
- $T_{clkT3}$  = Period of input clock to Timer B3 [s]

In this application, the maximum measurable speed is limited to 6000rpm.

**Notes:** To ensure an accurate speed calculation, you must choose the input clock of Timer B3 so that the calculation period of speed processing (in this case, 900 $\mu$ s) is represented in Timer B3 as a value lower than 0x7FFFH ( $900 \cdot 10^{-6} / T_{clkT2} \leq 0x7FFFH$ ).

#### 4.3.1.3 Position Reset with Rotor Alignment

After reset, the rotor position is unknown, because a Quadrature Encoder does not give an absolute position until the index pulse arrives. As shown in **Figure 4-5**, the rotor position must be aligned with the  $d$  axis of the d-q coordinate system before a motor begins running. The alignment algorithm is shown in **Figure 4-6**. First, the position is set to zero, independent of the actual rotor position. (The value of the Quadrature Encoder does not affect this setting). Then the  $I_d$  current is set to alignment current. The rotor is now aligned to the required position. After rotor stabilization, the encoder is reset to the zero position, then the  $I_d$  current is set back to zero, and alignment is finished. The alignment is executed only once during the first transition from the Stop to the Run state of the RUN / STOP switch.

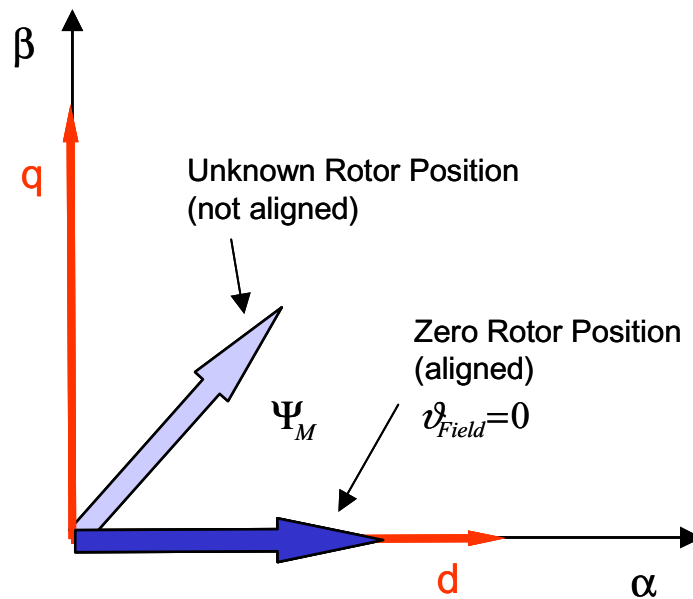

Figure 4-5 Rotor Alignment

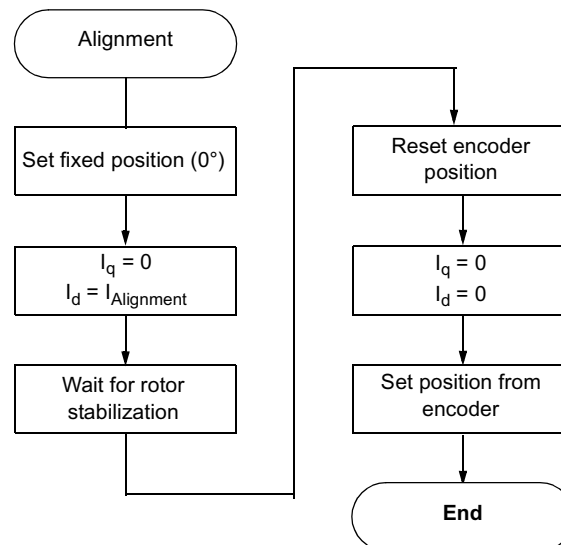
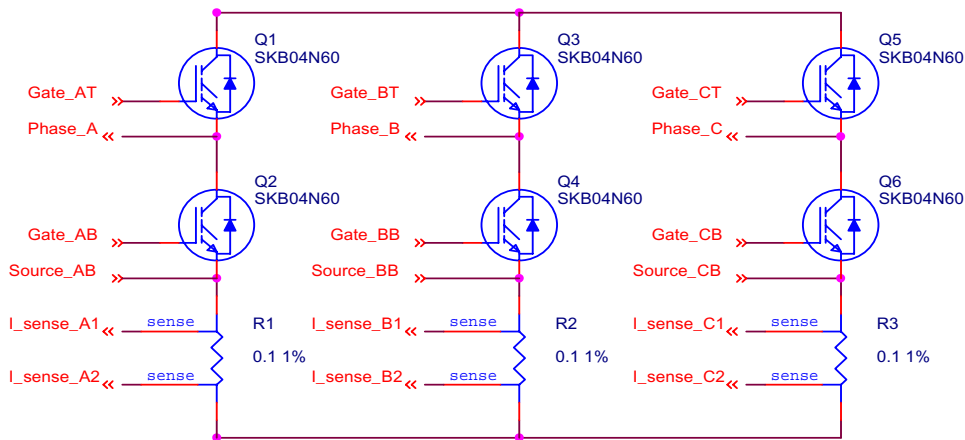

Figure 4-6 Rotor Alignment Flow Chart

### 4.3.2 Current Sensing

Phase currents are measured by a shunt resistor in each phase. A voltage drop on the shunt resistor is amplified by an operational amplifier, and shifted up by 1.65V. The resulting voltage is converted by an A/D converter; see [Figure 4-7](#) and [Figure 4-8](#).



**Figure 4-7 Current Shunt Resistors**

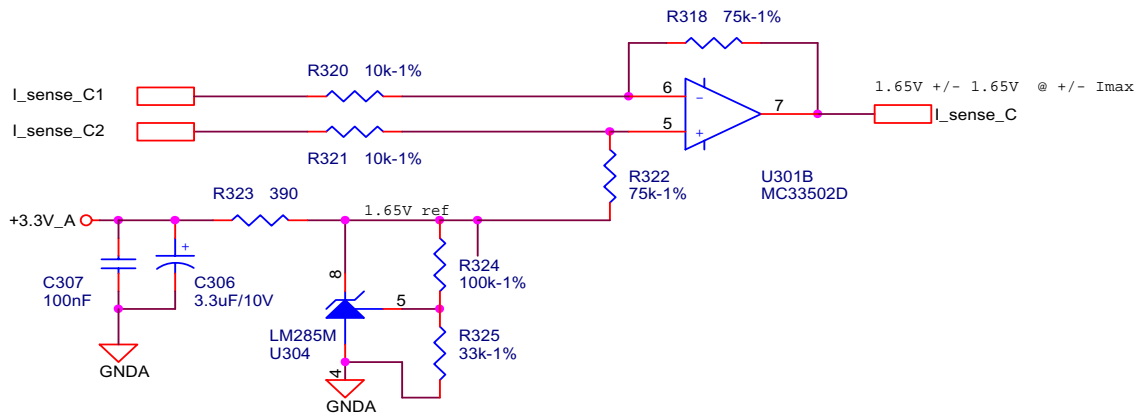
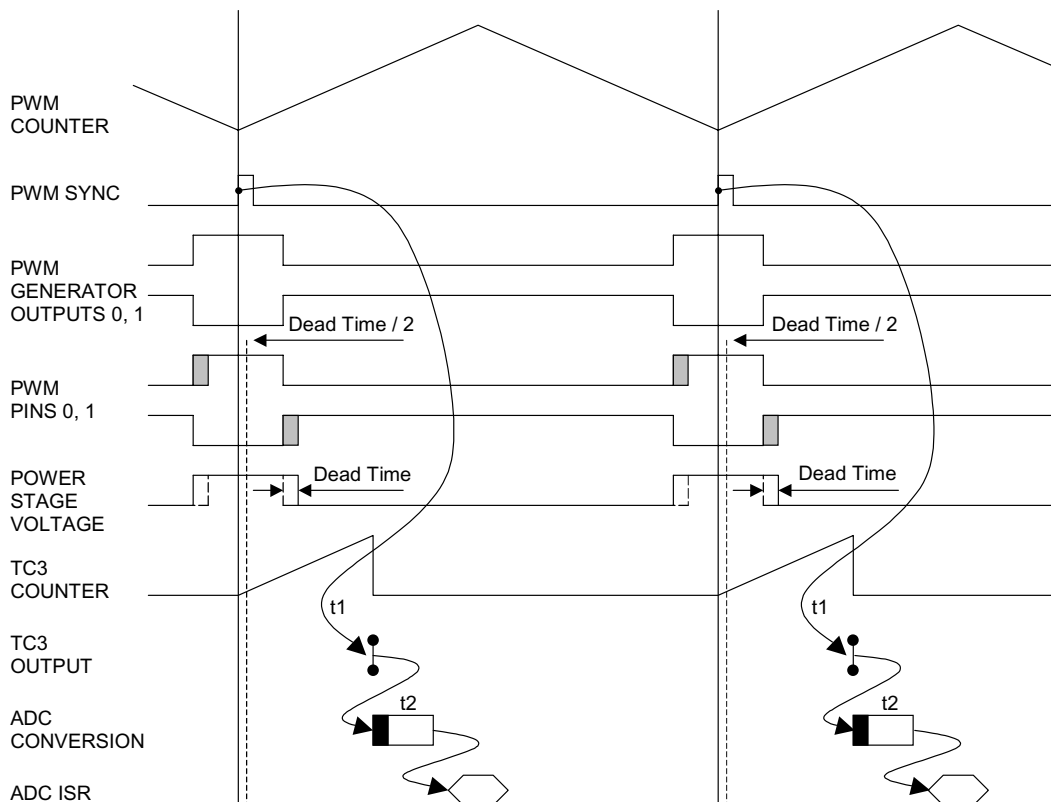

**Figure 4-8 Current Amplifier**

As shown in [Figure 4-7](#), the currents can only be measured in certain circumstances. For example, the current flows through Phase A (and shunt resistor R1) only if transistor Q2 is switched on. Likewise, the current in Phase B can be measured if transistor Q4 is switched on, and the current in Phase C can be measured if transistor Q6 is switched on. A voltage shape analysis must be performed to get a moment of current sensing.

The voltage shapes of two different PWM periods are shown in [Figure 4-11](#). The voltage shapes correspond to center-aligned PWM sinewave modulation. As shown, the best moment of current sampling is in the middle of the PWM period, where all bottom transistors are switched on.

To set the exact moment of sampling, the 56F8300 family offers the ability to synchronize ADC and PWM modules via the SYNC signal. This exceptional hardware feature, patented by Freescale, is used for current sensing. The PWM outputs a synchronization pulse, which is connected as an input to the synchronization module TC3 (Quad Timer C, counter / timer 3). A high-true pulse occurs for each reload of the PWM, regardless of the state of the LDOK bit. The intended purpose of TC3 is to provide a user-selectable delay between the PWM SYNC signal and the updating of the ADC values. A conversion process can be initiated by the SYNC input, which is an output of TC3. The time diagram of the automatic synchronization between PWM and ADC is shown in [Figure 4-9](#).



**Figure 4-9 Time Diagram of PWM and ADC Synchronization**

However, all three currents cannot be measured from one voltage shape. The PWM period II illustrated in [Figure 4-11](#) shows a moment when the bottom transistor of Phase A is switched on for a very short time. If the time on is shorter than a critical time, the current can not be accurately measured. The critical time is given by hardware configuration (transistor commutation times, response delays of the processing electronics, etc.). Therefore, only two currents are measured and a third current is calculated from the following equation:

$$0 = i_A + i_B + i_C \quad \text{EQ. 4-5}$$

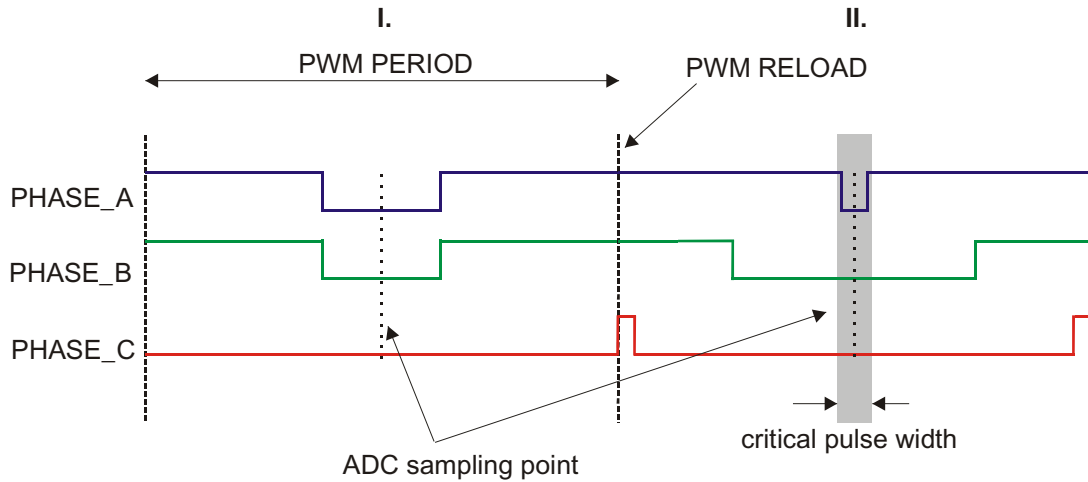

**Figure 4-10 Voltage Shapes of Two Different PWM Periods**

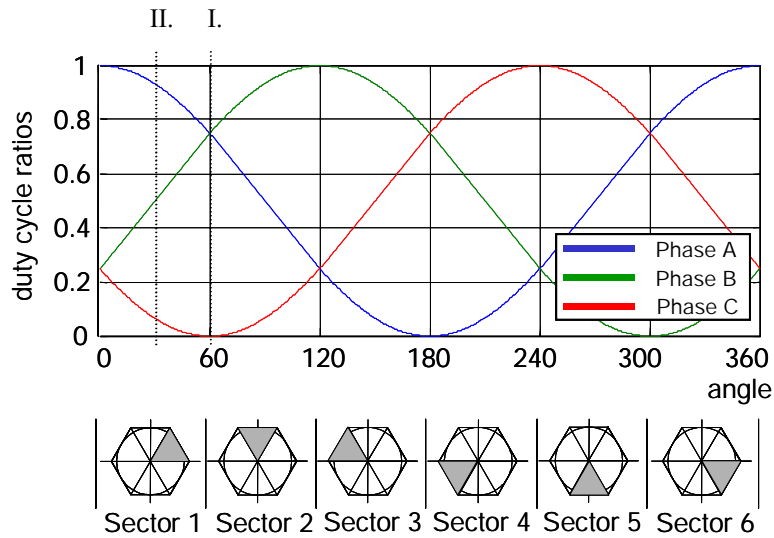

**Figure 4-11 3-Phase Sinewave Voltages and Corresponding Sector Value**

A decision must now be made about which phase current should be calculated. The simplest technique is to calculate the current of the most positive voltage phase. For example, Phase A generates the most positive voltage within section 0 to 60°, Phase B within section 60° to 120°, and so on; see [Figure 4-11](#)

In this case, the output voltages are divided into six sectors, as shown in [Figure 4-11](#) The current calculation is then made according to the actual sector value.

Sectors 1 and 6:

$$i_A = -i_B - i_C \tag{EQ. 4-6}$$

Sectors 2 and 3:

$$i_B = -i_A - i_C \quad \text{EQ. 4-7}$$

Sectors 4 and 5:

$$i_C = -i_B - i_A \quad \text{EQ. 4-8}$$

**Notes:** The sector value is used for current calculation only, and has no other meaning in the sinewave modulation. But if we use any type of space vector modulation, we can get the sector value as part of space vector calculation.

### 4.3.3 Voltage Sensing

The DCBus voltage sensor is represented by a simple voltage divider. The DCBus voltage does not change rapidly. It is nearly constant, with the ripple given by the power supply structure. If a bridge rectifier is used for rectification of the AC line voltage, the ripple frequency is twice the AC line frequency. If the power stage is designed correctly, the ripple amplitude should not exceed 10% of the nominal DCBus value.

The measured DCBus voltage must be filtered to eliminate noise. One of the easiest and fastest techniques is the first order filter, which calculates the average filtered value recursively from the last two samples and coefficient C:

$$u_{DCBusFilt}(n+1) = (Cu_{DCBusFilt}(n+1) - Cu_{DCBusFilt}(n)) - u_{DCBusFilt}(n) \quad \text{EQ. 4-9}$$

To speed up the initialization of the voltage sensing (the filter has exponential dependency with constant of 1/N samples), the moving average filter, which calculates the average value from the last N samples, can be used for initialization:

$$u_{DCBusFilt} = \sum_{n=1}^{-N} u_{DCBus}(n) \quad \text{EQ. 4-10}$$

### 4.3.4 Power Module Temperature Sensing

The power module temperature measured is used for thermal protection. The hardware realization is shown in [Figure 4-12](#). The circuit consists of four diodes connected in series, a bias resistor, and a noise suppression capacitor. The four diodes have a combined temperature coefficient of 8.8mV/°C. The resulting signal, *Temp\_sense*, is fed back to an A/D input, where software can be used to set safe operating limits. In this application, the temperature, in Celsius, is calculated according to the conversion equation:

$$temp = \frac{Temp\_sense - b}{a} \quad \text{EQ. 4-11}$$

Where:

<i>temp</i>	= Power module temperature in centigrade
<i>Temp_sense</i>	= Voltage drop on the diodes, which is measured by ADC [V]
<i>a</i>	= Diodes-dependent conversion constant ( $a = -0.0073738$ )
<i>b</i>	= Diodes-dependent conversion constant ( $b = 2.4596$ )

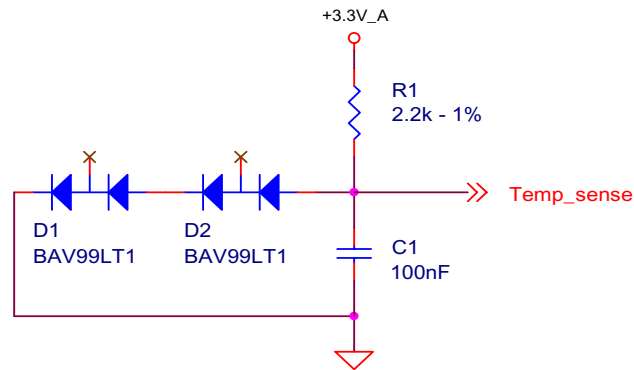

**Figure 4-12 Temperature Sensing**

## 5. Hardware Implementation

### 5.1 Hardware Set-Up

This section explains the hardware set-up for targeting a 56F83xxEVM.

The application can run on Freescale's motor control hybrid controllers using the 56F83xxEVM, Freescale's 3-Phase AC / BLDC high voltage power stage, and the BLDC high voltage motor with a Quadrature Encoder and integrated brake. All components are an integral part of Freescale's embedded motion control development tools. Application hardware set-up is shown in [Figure 5-1](#)

The system hardware set-up for a particular hybrid controller varies only by the EVM used. The application level of the software is identical for all hybrid controllers. The EVM and chip differences are handled by the off-chip software drivers for the particular hybrid controller EVM.

Detailed application hardware set-up can be found in the **Targeting Freescale 56F83xx Platform** manual for the specific device being implemented.



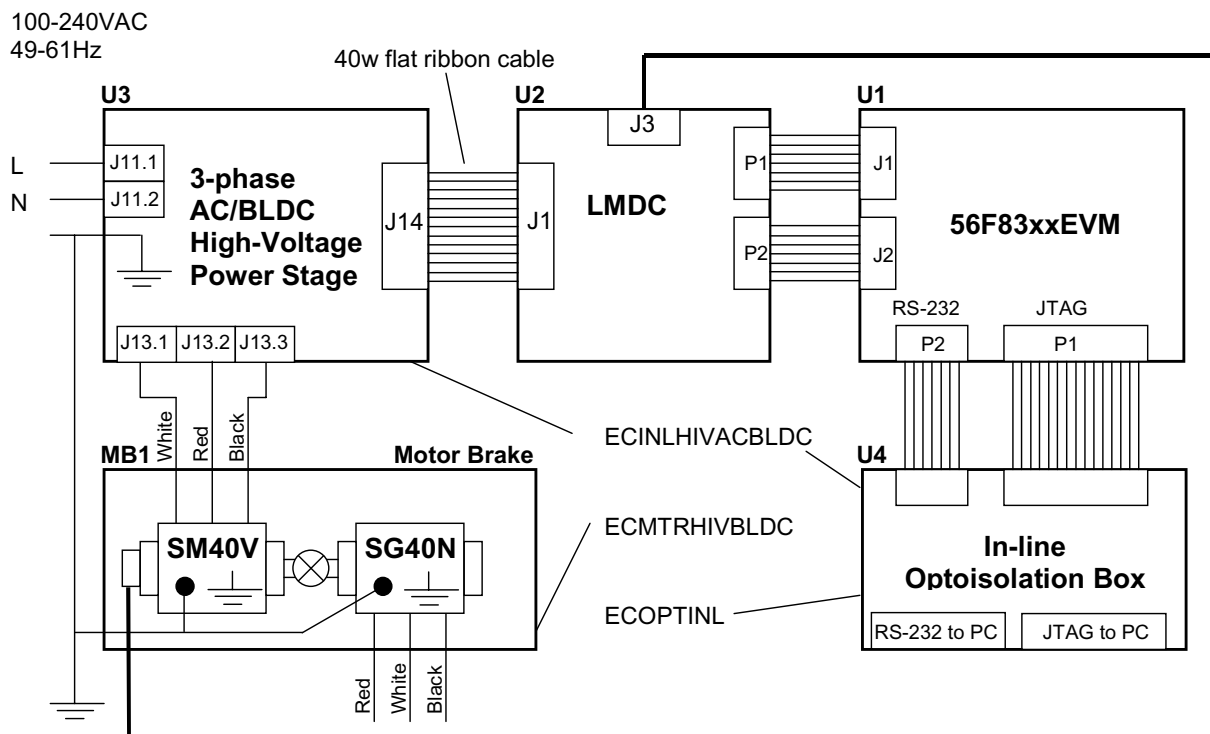

**Figure 5-1 High-Voltage Hardware System Configuration**

All system parts are supplied and documented in these references:

- **U1** - Controller Board for 56F83xx
  - Supplied as 56F83xxEVM
  - Described in the **56F83xx Evaluation Module Hardware User's Manual** for the specific device being implemented
- **U2** - Legacy Motor Daughter Card (LMDC)
  - Supplies limited; please contact your Freescale representative
- **U3** - 3-phase AC / BLDC High-Voltage Power Stage
  - Supplied in a kit with the In-Line Optoisolation Box, Freescale Part #ECINLHIVACBLDC
  - Described in the **3-Phase AC BLDC High-Voltage Power Stage User's Manual**
- **U4** - In-Line Optoisolation Box
  - Supplied in a kit with the 3-Phase AC BLDC High-Voltage Power Stage, Freescale Part #ECINLHIVACBLDC

Or

  - Supplied by itself, Freescale Part #ECOPTINL
  - Described in the **In-Line Optoisolation Box Manual**

**WARNING:** To avoid potential damage to the development equipment, the use of an In-line Optoisolation Box is strongly recommended during development.

- **MB1** Motor-Brake SM40V + SG40N

**Notes:** The application software is targeted for a PM Synchronous Motor with sinewave Back-EMF shape. In this demonstration application, a BLDC motor is used instead, due to the availability of the BLDC motor (MB1). Although the Back-EMF shape of this motor is not an ideal sinewave, it can be controlled by the application software. The drive parameters will be ideal, with a PMSM motor with an exact sinewave Back-EMF shape.

A detailed description of the individual board can be found in the appropriate **56F80x Evaluation Module User's Manual** or **56F83xx Evaluation Module User Manual**, or on the Freescale web site: [www.freescale.com](http://www.freescale.com)

The Users Manual includes the schematic of the board, description of individual function blocks, and a bill of materials. The individual boards can be ordered from Freescale as standard products.

## 6. Software Design

This section explains the software design for targeting a 56F83xxEVM and describes the design of the drive's software blocks. The software description comprises these topics:

- Main software flow chart
- Data flow
- State diagram

For more information on the system blocks used, refer to [Section 4.3](#).

### 6.1 Main Software Flow Chart

The main software flow chart incorporates the Main routine entered from Reset (see [Figure 6-1](#)) and Interrupt states (see [Figure 6-2](#), and [Figure 6-3](#)). The Main routine includes the initialization of the hybrid controller and the main loop.

The software consist of processes:

- The **Application Control** process is the highest software level and precedes settings for other software levels. Inputs for this level are the RUN / STOP switch, UP / DOWN buttons for manual control, and PC master software (via the registers shown in [Section 6.2](#)). This process is handled by Application Control Processing called from Main; see [Figure 6-1](#).
- The **PM Synchronous Motor (PMSM) Control** process provides most of the motor control functionality. It is split into:
  - **Current Processing**, which is called from ADC Complete Interrupt (see [Figure 6-2](#)) once per two PWM reloads, with a period 125 $\mu$ s. It can also be set to each PWM reload (62.5 $\mu$ s), but the PC master software recorder *pcmasterdrvRecorder()* must be removed from the code.
  - **Speed Processing**, which is called from the Quadrature Timer D0 Interrupt (see [Figure 6-3](#)) with the period PER\_TMR\_POS\_SPEED\_US (900 $\mu$ s). The advantage of splitting the current and the speed control processes is that current control can be executed with a high priority and frequency of calls, while the execution of the speed control is not that highly prioritized.
- The **Analog Sensing** process handles sensing, filtering and correction of analog variables (phase currents, temperature, DCBus voltage). It is provided by Analog Sensing Processing (see [Figure 6-2](#))

and Analog Sensing ADC Phase Set, split from Analog Sensing Processing because it sets ADC according to the *svmSector* variable, calculated after PMSM Control Current Processing.

- **Position and Speed Measurement** processes are provided by hardware Timer modules and the functions giving the actual speed and position; see [Section 4.3.1](#)
- **LED Indication** processing is called from Quadrature Timer D0 Interrupt, which provides the time base for the LEDs' flashing
- The **Fault Control** process is split into:
  - **Background** (see [Figure 6-1](#)), which checks the Overheating, Undervoltage and Position Sensing Faults
  - **PWM Fault ISR** (see [Figure 6-2](#)) takes care of Overvoltage and Overcurrent Faults, which cause a PWM B Fault interrupt
- The **Brake Control** process is dedicated to the brake transistor control, which maintains the DCBus voltage level. It is called from Main (see [Figure 6-1](#)).
- The **UP / DOWN Button** and **Switch Control** processes are subprocesses of Application Control and are described in [Section 7.4](#).

The Up / Down Button processes are split into:

- **Button Processing Interrupt**, called from Quadrature Timer D0 Interrupt (see [Figure 6-3](#))
- **Button Processing Background**, called from *ApplicationControlProcessing*

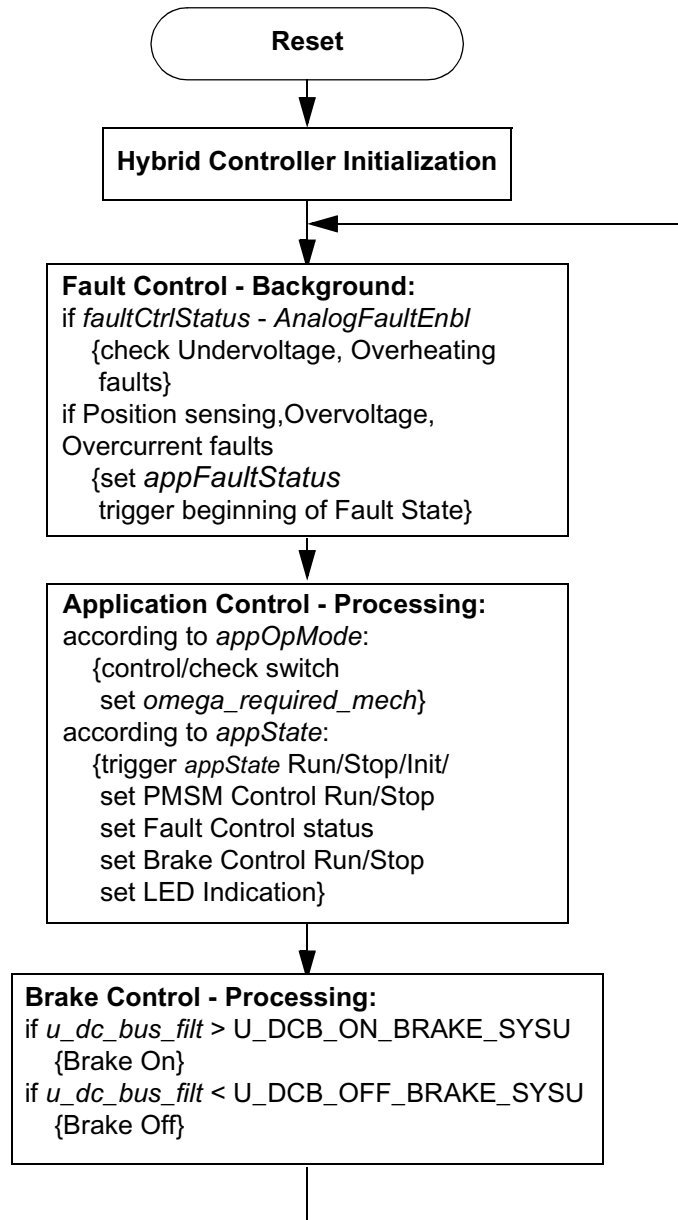

**Figure 6-1 Software Flow Chart - General Overview I**

- The **Switch** process is split into:
  - **Switch Filter Processing**, called from Quad Timer D0 Interrupt (see [Figure 6-3](#))
  - **Switch Get State**, called from Application Control processing, which handles:
    - Manual switch control
    - Switch Get State: “PC master software” (in PC master application operating mode)

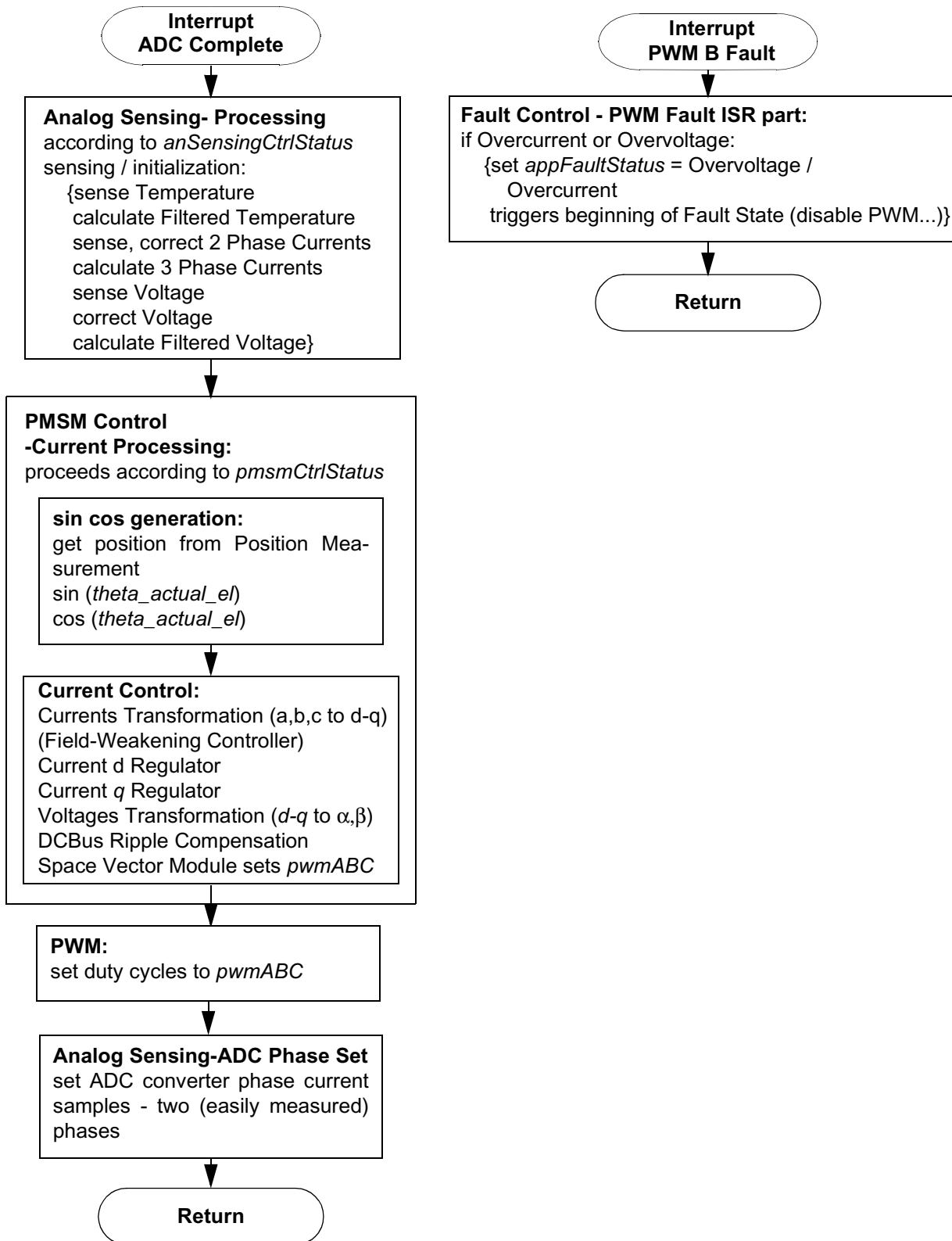

Figure 6-2 Software Flow Chart - General Overview II

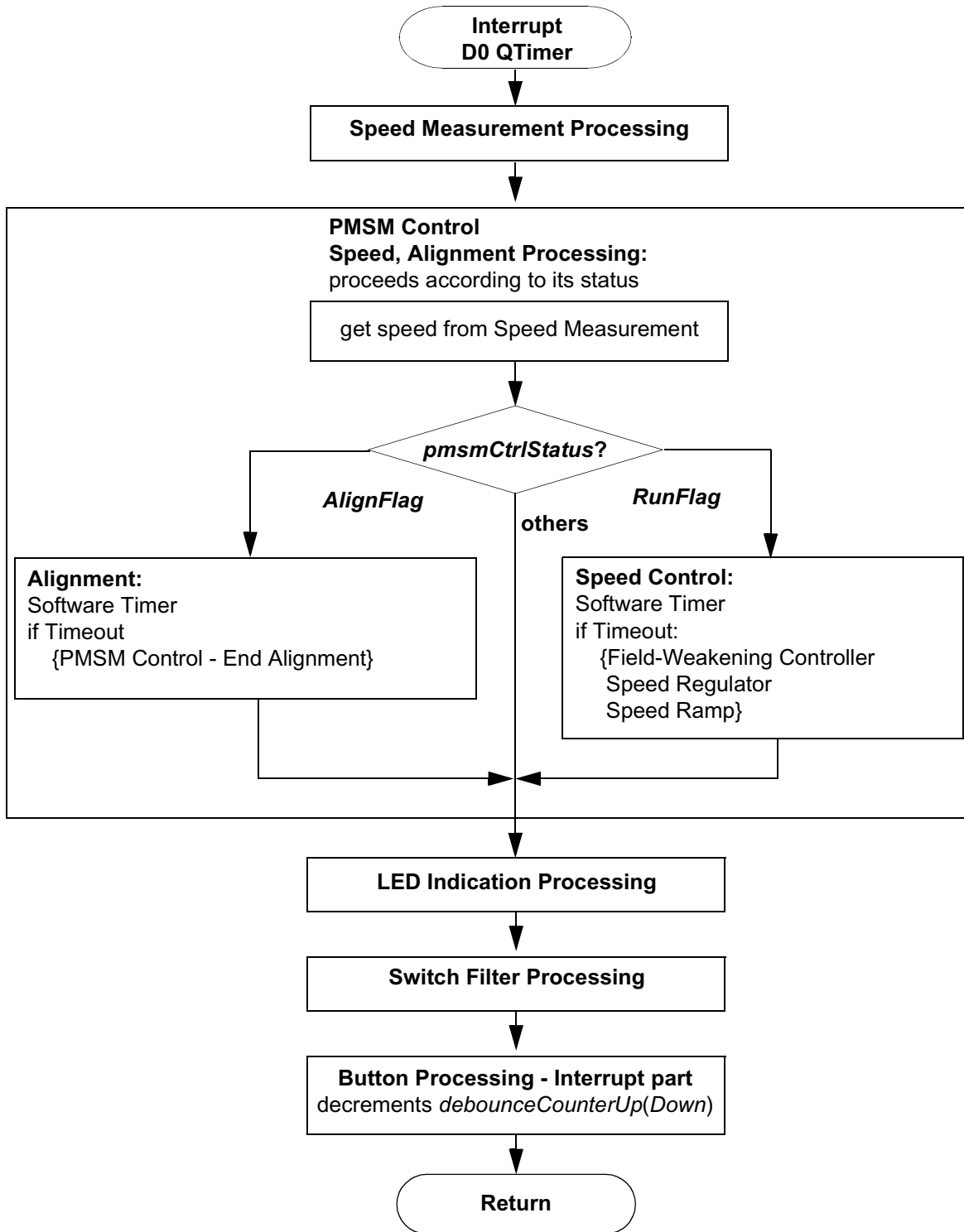

Figure 6-3 S/W Flow Chart - General Overview III

## 6.2 Data Flow

The PMSM Vector Control Drive Control Algorithm is described in the data flow charts shown in **Figure 6-4** and **Figure 6-5**. The variables and constants described should be clear from their names.

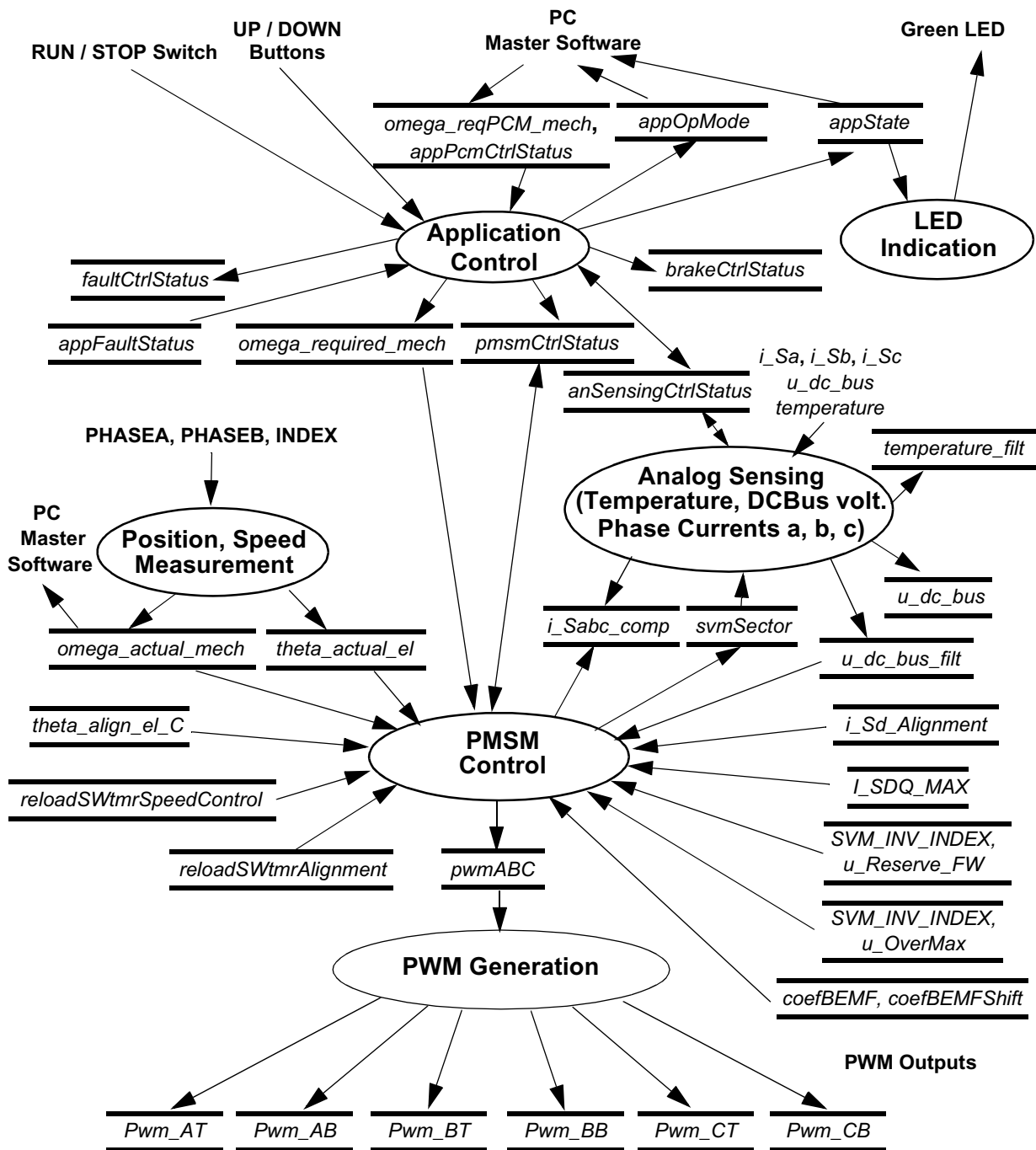

Figure 6-4 Data Flow - Part 1

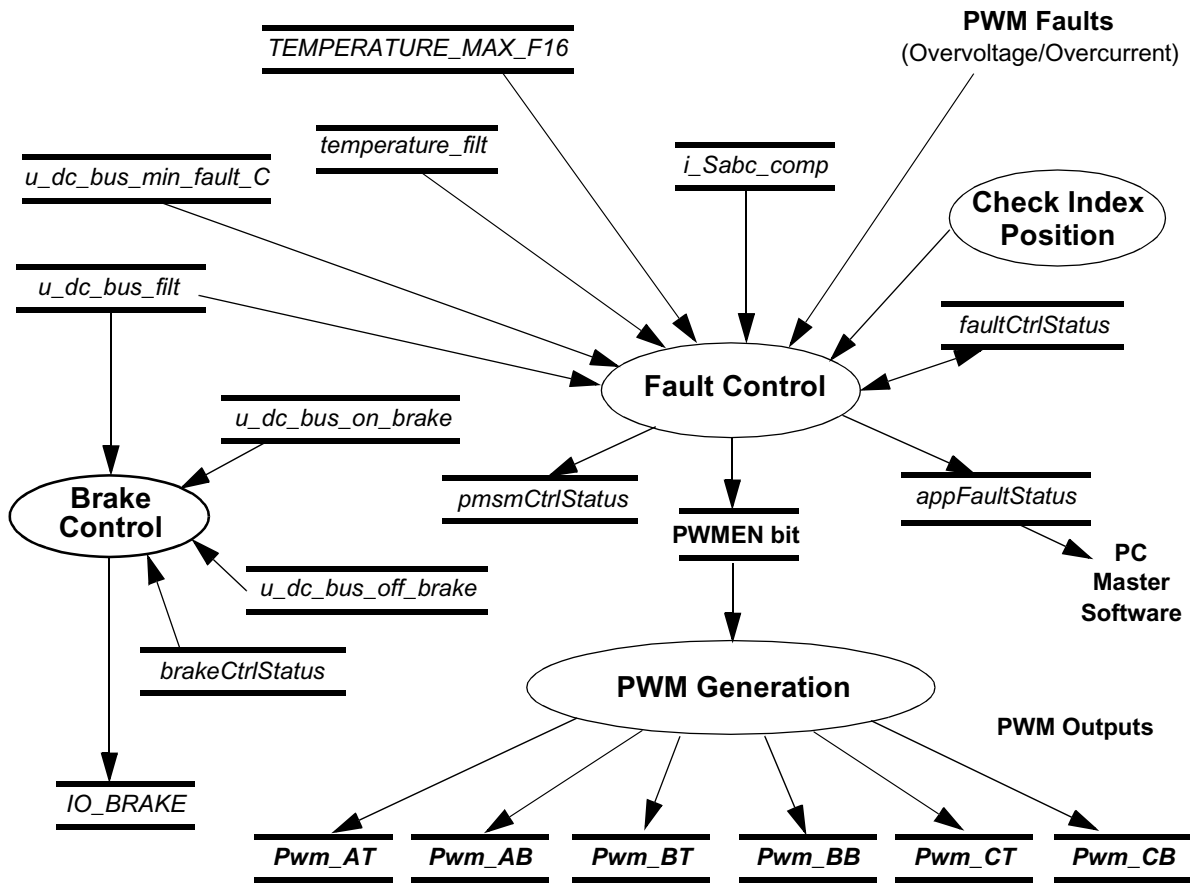

Figure 6-5 Data Flow - Part 2

The data flows consist of the processes described in the following sections.

### 6.2.1 Application Control Process

The Application Control process is the highest software level, which precedes settings for other software levels.

The process state is determined by the variable *appState*.

The application can be controlled either:

- Manually
- From PC master software

The Manual or PC master application operating mode is determined by the setting of *appOpMode*.

For Manual control, the input of this process is the RUN / STOP switch and UP / DOWN buttons.



The PC master software communicates via:

- *omega\_reqPCM\_mech*, which is the required angular speed from PC master software
- *appPcmCtrlStatus*, which consists of the flags *StartStopCtrl* for START / STOP
- *RequestCtrl* for changing the application's operating mode *appOpMode* to Manual or PC control
- *appFaultStatus*, which indicates faults

The other processes are controlled by setting:

- *pmsmCtrlStatus*
- *omega\_required\_mech*
- *appPcmCtrlStatus*
- *brakeCtrlStatus*
- *faultCtrlStatus*

### 6.2.2 LED Indication Process

This process controls the LEDs' flashing according to *appState*.

### 6.2.3 Analog Sensing Process

The Analog Sensing process handles:

- Sensing
- Filtering
- Correction of analog variables:
  - Phase currents
  - Temperature
  - DCBus voltage

### 6.2.4 Position and Speed Measurement Process

The Position and Speed Measurement process gives:

- Mechanical angular speed, *omega\_actual\_mech*
- Electrical position, *theta\_actual\_el*

### 6.2.5 PM Synchronous Motor (PMSM) Control Process

The PMSM Control process provides most of the motor control functionality.

**Figure 6-6** shows the data flow inside the PMSM Control process, including essential subprocesses:

- Sine
- Cosine Transformations
- Current Control
- Speed
- Alignment Control
- Field-Weakening

The Sine and Cosine Transformations generate  $\sin\cos\_theta\_el$  with the components  $sine$ ,  $cosine$  according to electrical position  $theta\_actual\_el$ . It is provided in a look-up table.

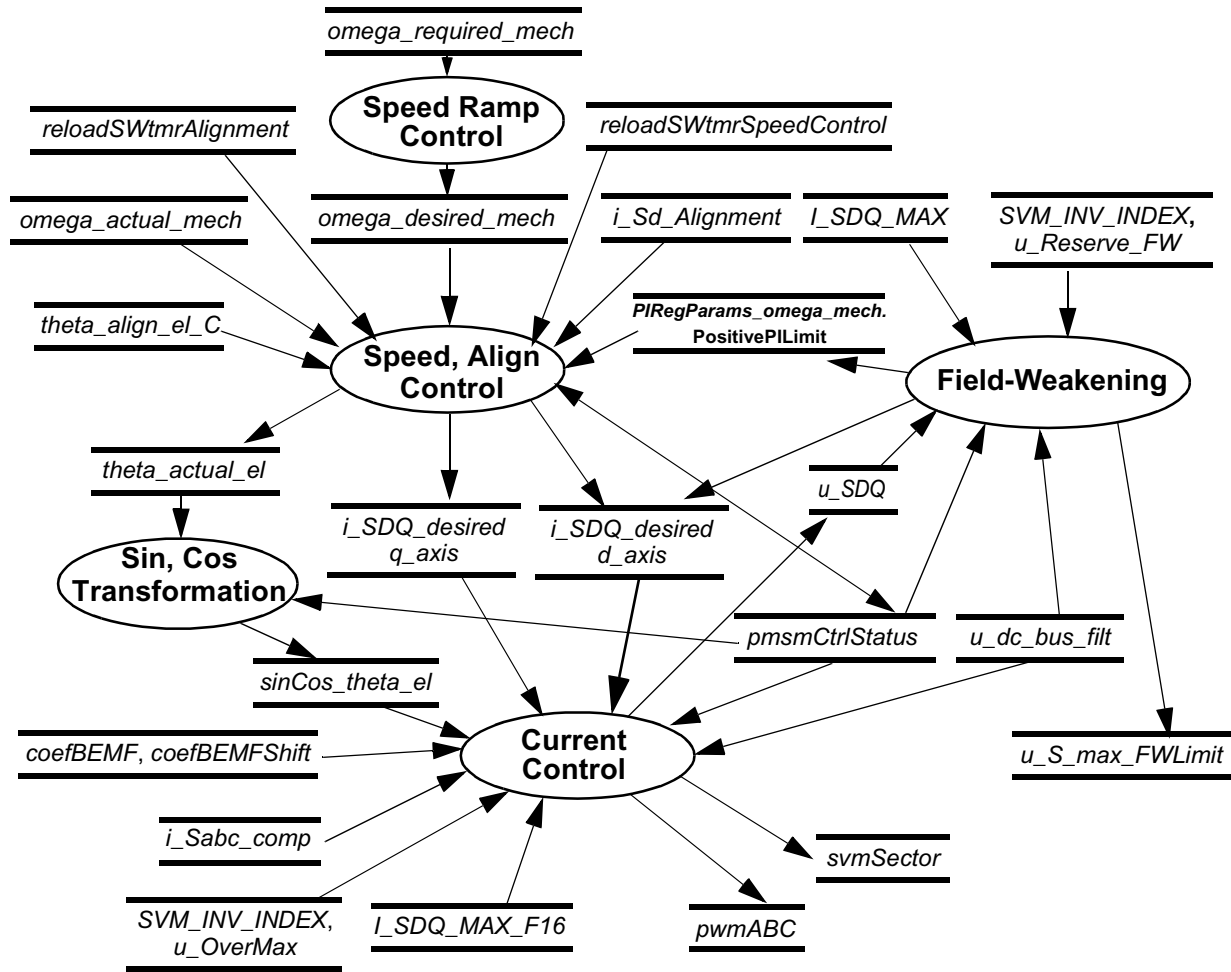

Figure 6-6 Data Flow - PMSM Control

### 6.2.5.1 Current Control Process

The data flow inside the Current Control process is detailed in Figure 6-7. The measured phase currents  $i\_Sabc\_comp$  are transformed into  $i\_SDQ\_lin$  using  $\sin\cos\_theta\_el$ ; see Section 3.3.3. Both  $d$  and  $q$  components are regulated by independent Proportional Integrational (PI) regulators to  $i\_SDQ\_desired$  values. The outputs of the regulators are  $u\_SDQ\_lin$ .

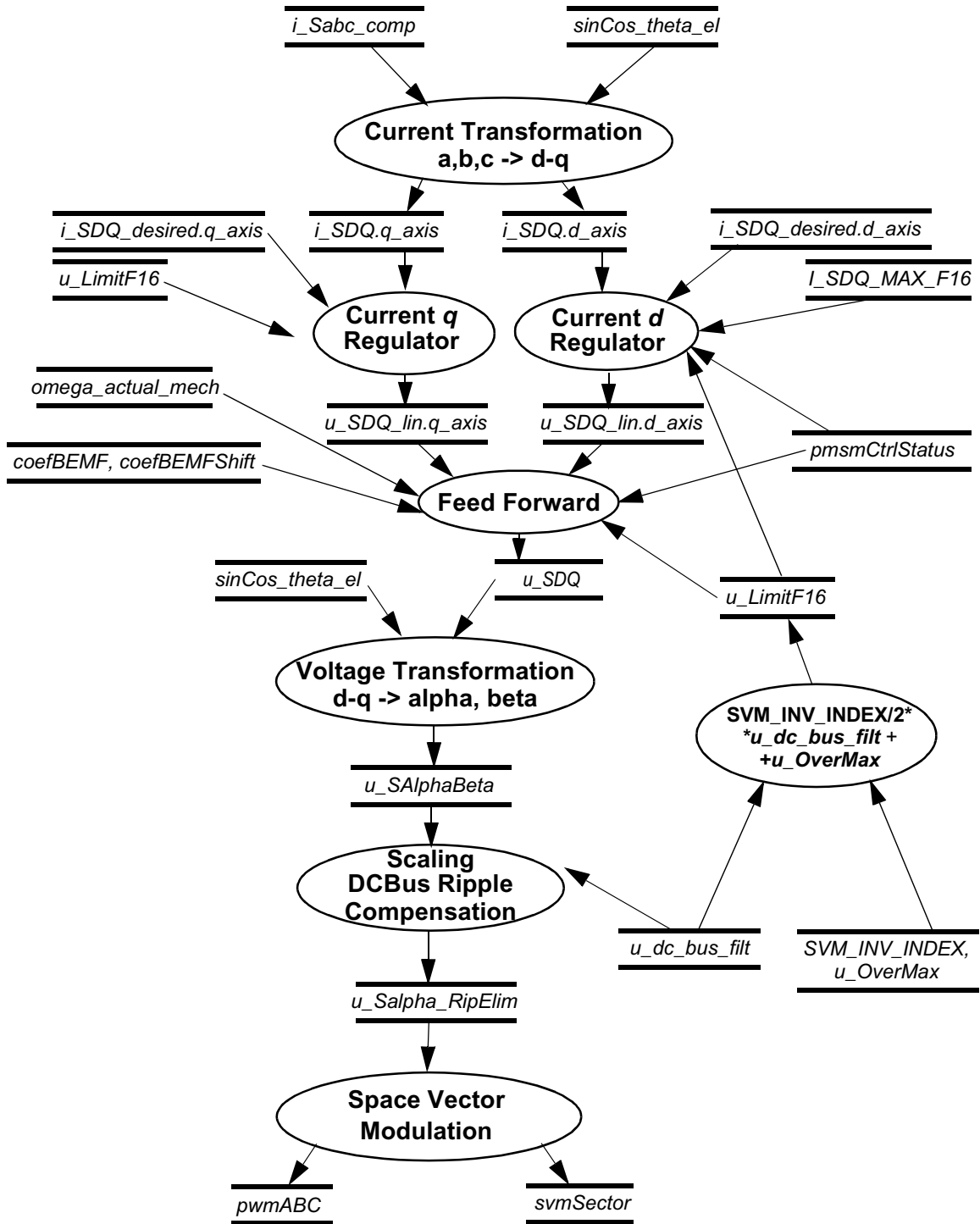

Figure 6-7 Data Flow - PMSM Control - Current Control

The Feed Forward process provides the following calculations:

$$u\_SDQ.q\_axis = \text{coefBEMF} \cdot 2^{\text{coefBEMFShft}} \cdot \text{omega\_actual\_mech} + u\_SDQ.lin.q\_axis \quad \text{EQ. 6-1}$$

$$u\_SDQ.d\_axis = u\_SDQ.lin.d\_axis \quad \text{EQ. 6-2}$$

The  $u\_SDQ$  voltages are transformed into  $u\_SAlphaBeta$  (see [Section 3.3.3](#)) by the Voltage Transformation process. The Scaling DCBus Ripple Compensation block scales  $u\_SAlphaBeta$  (according  $u\_dc\_bus\_filt$ ) to  $u\_Salpha\_RipElim$ , described in the `svmlimDcBusRip` function in the Motor Control Library. The space vector modulation process generates duty cycle `pwmABC` and `svmSector` according to  $u\_Salpha\_RipElim$ .

The  $u\_LimitF16$  is a voltage limit for current controllers. The  $u\_OverMax$  constant is used to increase the limitation of  $u\_SDQ$  voltages over maximum  $SVM\_INV\_INDEX / 2 * u\_dc\_bus\_filt$  determined by the DCBus voltage and space vector modulation. Although the `pwmABC` will be limited by the space vector modulation process functions, the reserve is used for field-weakening controller dynamics. In the stable state, the  $u\_SDQ$  voltages vector will not exceed  $u\_S\_max\_FWLimit$ ; see [Section 6.2.5.4](#).

### 6.2.5.2 Speed Ramp

This process generates angular speed  $omega\_desired\_mech$  from angular speed  $omega\_required\_mech$  with a linear ramp. The speed ramp is implemented so as not to saturate the speed regulator during acceleration.

### 6.2.5.3 Speed, Alignment Control Process

The process controls the  $i\_SDQ\_desired.q\_axis$  current according to the PMSM Control Process Status.

For Alignment status, it sets  $i\_SDQ\_desired.d\_axis$  to  $i\_Sd\_Alignment$  and  $i\_SDQ\_desired.q\_axis$  to 0.

For Run status, it controls the  $omega\_actual\_mech$  speed to  $omega\_desired\_mech$  by calculation of the PI regulator with  $i\_SDQ\_desired.q\_axis$  output.

### 6.2.5.4 Field-Weakening Process

The Field-Weakening process provides control of  $i\_SDQ\_desired.d\_axis$  in order to achieve higher motor speeds by the field-weakening technique. The control algorithm is shown in [Figure 6-8](#). The  $u\_S\_max\_FWLimit$  is computed from  $u\_dc\_bus\_filt$ . To maintain voltage reserve, the  $u\_Reserve\_FW$  is subtracted from the maximum  $SVM\_INV\_INDEX / 2 * u\_dc\_bus\_filt$ , determined by DCBus voltage and space vector modulation. The reserve is used for field-weakening controller dynamics; in the stable state, the  $u\_SDQ$  voltages vector will not exceed  $u\_S\_max\_FWLimit$ .

This process also provides voltage limitation  $i\_SDQ\_desired.d\_axis^2 + i\_SDQ\_desired.q\_axis^2 < (I\_SDQ\_MAX\_F16)^2$  by setting:

$$\text{PIRegParams\_omega\_mech.PositvePILimit} = \sqrt{I\_SDQ\_MAX\_F16^2 - i\_SDQ\_desired.d\_axis^2} \quad \text{EQ. 6-3}$$

$$\text{PIRegParams\_omega\_mech.NegativePILimit} = -\sqrt{I\_SDQ\_MAX\_F16^2 - i\_SDQ\_desired.d\_axis^2} \quad \text{EQ. 6-4}$$

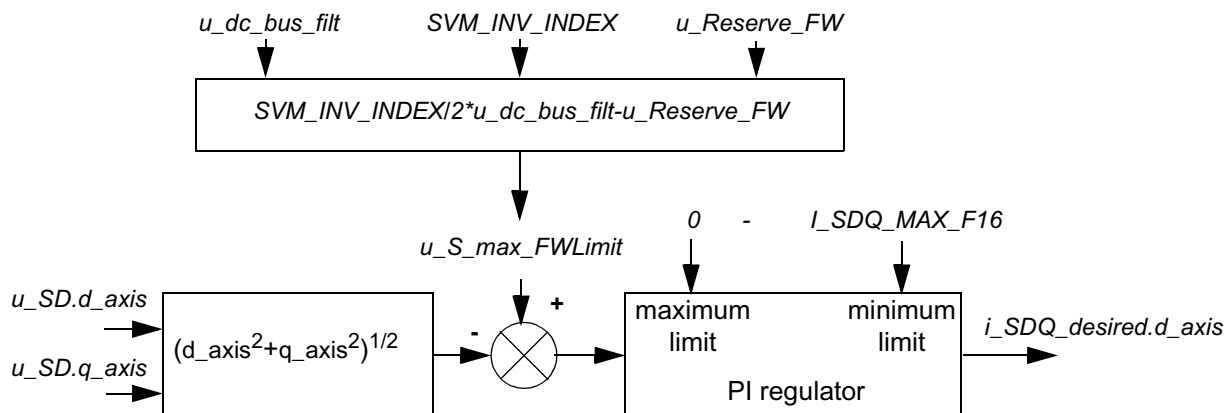

**Figure 6-8 Field-Weakening Controller**

## 6.2.6 Brake Control Process

The Brake Control process maintains DCBus voltage level via the IO\_BRAKE driver, which controls the brake switch. The voltage comparison levels are:

- $u_{dc\_bus\_on\_brake}$ , which is initialized according to mains voltage with either:
  - $U\_DCB\_ON\_BRAKE\_MAINS230\_F16$
  - $U\_DCB\_ON\_BRAKE\_MAINS115\_F16$
- $u_{dc\_bus\_off\_brake}$ , initialized with either:
  - $U\_DCB\_OFF\_BRAKE\_MAINS230\_F16$
  - $U\_DCB\_OFF\_BRAKE\_MAINS115\_F16$

## 6.2.7 PWM Generation Process

The PWM Generation process controls the generation of PWM signals, driving the 3-phase inverter.

The input is  $pwmABC$ , with three PWM components scaled to the range  $<0,1>$  of type  $Frac16$ . The scaling (according to PWM module setting) and the PWM module control (on the hybrid controller) is provided by the PWM driver.

## 6.2.8 Fault Control Process

The Fault Control process checks these faults:

- Overheating
- Undervoltage
- Overvoltage
- Overcurrent
- Position Sensing

Overheating and Undervoltage are checked by the comparisons:

- $temperature\_filt < TEMPERATURE\_MAX\_F16$
- $u\_dc\_bus\_filt < u\_dc\_bus\_min\_fault\_C$ , where  $u\_dc\_bus\_min\_fault\_C$  is initialized with  $U\_DCB\_MIN\_FAULT\_MAINS230\_F16$  or  $U\_DCB\_MIN\_FAULT\_MAINS115\_F16$ .

The Position Sensing fault is checked with the Check Index Position process.

The Overvoltage and Overcurrent faults are set in the PWMA Fault interrupt.

### 6.3 State Diagram

The software can be split into the processes shown in [Section 6.2](#).

These processes are described in the following sections:

- Hybrid Controller Initialization
- Application Control State Diagram
- PMSM Control State Diagram
- Fault Control State Diagram
- Analog Sensing State Diagram

All processes start with the Hybrid Controller Initialization state after Reset.

#### 6.3.1 Hybrid Controller Initialization

The hybrid controller Initialization state:

- Initializes:
  - PWM
  - Application control
  - PM Synchronous Motor (PMSM) Control
  - Analog sensing
  - Brake control
  - Fault control
  - LED indication
  - Button control
- Sets manual application operating mode
- Enables masked interrupts
- Sets “Application Control: Initialization Triggers”, which sets all affected processes to the Begin Application Initialization state

#### 6.3.2 Application Control State Diagram

The Application Control process is detailed in [Figure 6-9](#)

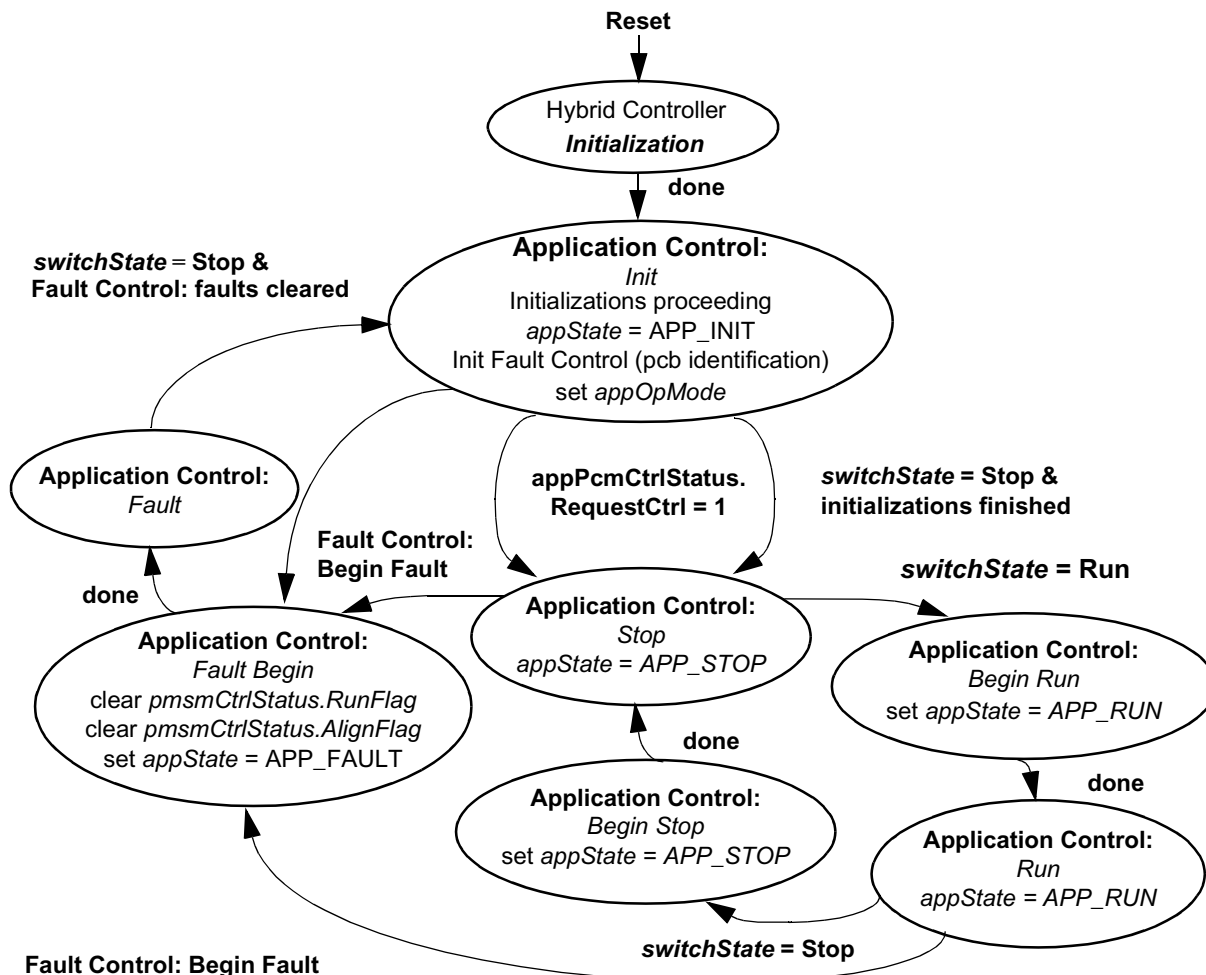

**Figure 6-9 State Diagram - Application Control**

After reset, the Hybrid Controller Initialization state is entered. The peripherals and variables are initialized in this state, and the application operating mode *appOpMode* is set to *Manual Control*.

When the state is finished, the Application Control *Init* state follows. As shown in [Figure 6-9](#):

- *appState = APP\_INIT*
- All subprocesses requiring initialization are proceeding
- PCB identification is provided
- The PWM is disabled, so no voltage is applied on motor phases

If the *appPcmCtrlStatus.RequestCtrl* flag is set from PC master software, the application operating mode *appOpMode* is toggled and the application operating mode can only be changed in this state. If the *switchState = Stop*, Application Control enters the *Stop* state.

The *switchState* is set according to the manual switch on the EVM or PC master software register *AppPcmCtrlStatus.StartStopCtrl*, depending on the application's operating mode.

In the Stop state:

- $appState = APP\_STOP$
- The PWM is disabled, so no voltage is applied on motor phases

When  $switchState = Run$ , the Begin Run state is processed. If there is a request to change application operating mode,  $appPcmCtrlStatus.RequestCtrl = 1$ , the application *Init* is entered and the application operating mode request can only be accepted in the *Init* or *Stop* state by transition to the *Init* state.

In the *Begin Run* state, all the processes provide settings to the *Run* state.

In the *Run* state:

- The PWM is enabled, so voltage is applied on motor phases
- The motor is running according to the state of all subprocesses
- If  $switchState = Stop$ , the Stop state is entered.

If a fault is detected, the *Begin Fault* state is entered, which is a subprocess of Fault control.

- It sets  $appState = APP\_FAULT$
- The PWM is disabled
- The subprocess PMSM Control is set to Stop

The Fault state can only move onto the *Init* state when  $switchState = Stop$ , and the Fault Control subprocess has successfully cleared all faults.

### 6.3.3 PMSM Control State Diagram

A state diagram of the PMSM Control process is illustrated in [Figure 6-10](#).



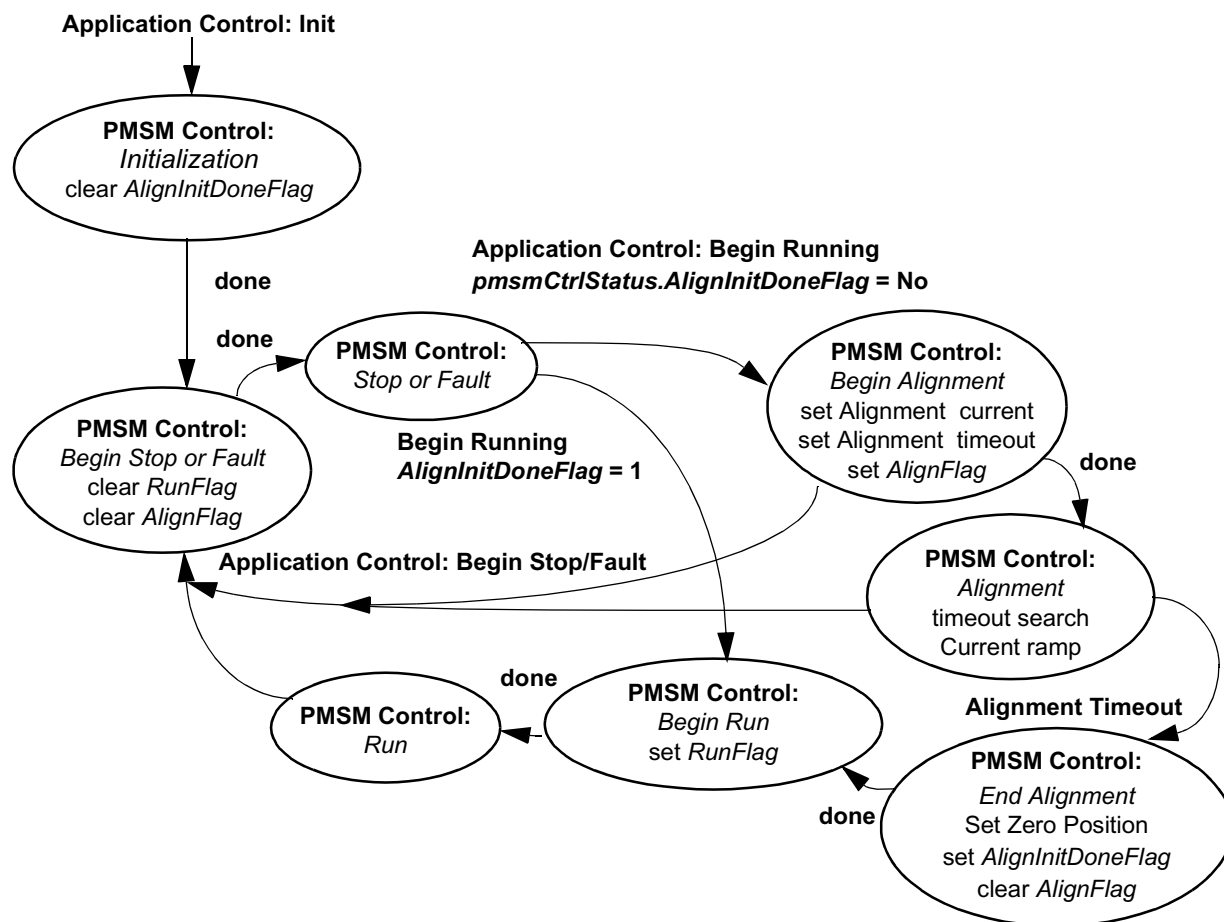

**Figure 6-10 State Diagram - PMSM Control**

When Application Control initializes, the PMSM Control subprocess initialization state is entered.

- The `AlignInitDoneFlag` is cleared, which means that alignment can proceed.
- The next PMSM Control state is *Begin Stop or Fault*.
- `RunFlag` and `AlignFlag` are cleared and the *Stop or Fault* state is entered.
- When “Application Control” equals “Begin Run”, the PMSM Control subprocess enters the *Begin Alignment* or *Begin Run* state, depending on whether or not the alignment initialization has already proceeded (flagged by `AlignInitDoneFlag`)

The alignment state is necessary for setting the zero position of position sensing; see [Section 4.3.1.3](#). In the state *Begin Alignment*:

The Alignment current and duration are set

The alignment is provided by setting desired current for `d_axis` to `i_Sd_Alignment` and for `q_axis` to 0.

The alignment state provides current control and time out search. When alignment time out occurs, *End Alignment* is entered. In that state, the Position Sensing Zero Position is set, so the position sensor is aligned with the real vector of the rotor flux. When the End Alignment state ends, the PMSM Control enters a regular *Run* state, where the motor is running at the required speed. If the Application Control state is set to *Begin Stop* or *Begin Fault*, the PMSM Control enters the *Begin Stop or Fault*, then the *Stop or Fault* state.

### 6.3.4 Fault Control State Diagram

The state diagram of the Fault Control subprocess is illustrated in **Figure 6-11** After the initialization, the fault conditions are searched. If any fault occurs, the *appFaultStatus* variable is set according to detected error; PWM is switched on (PWMEN bit = 0); the Fault state is entered. This state also causes Application Control: Fault state. If the faults are successfully cleared, this is signaled to the Application Control process. The Fault state is left when the Application Control *Init* state is entered.

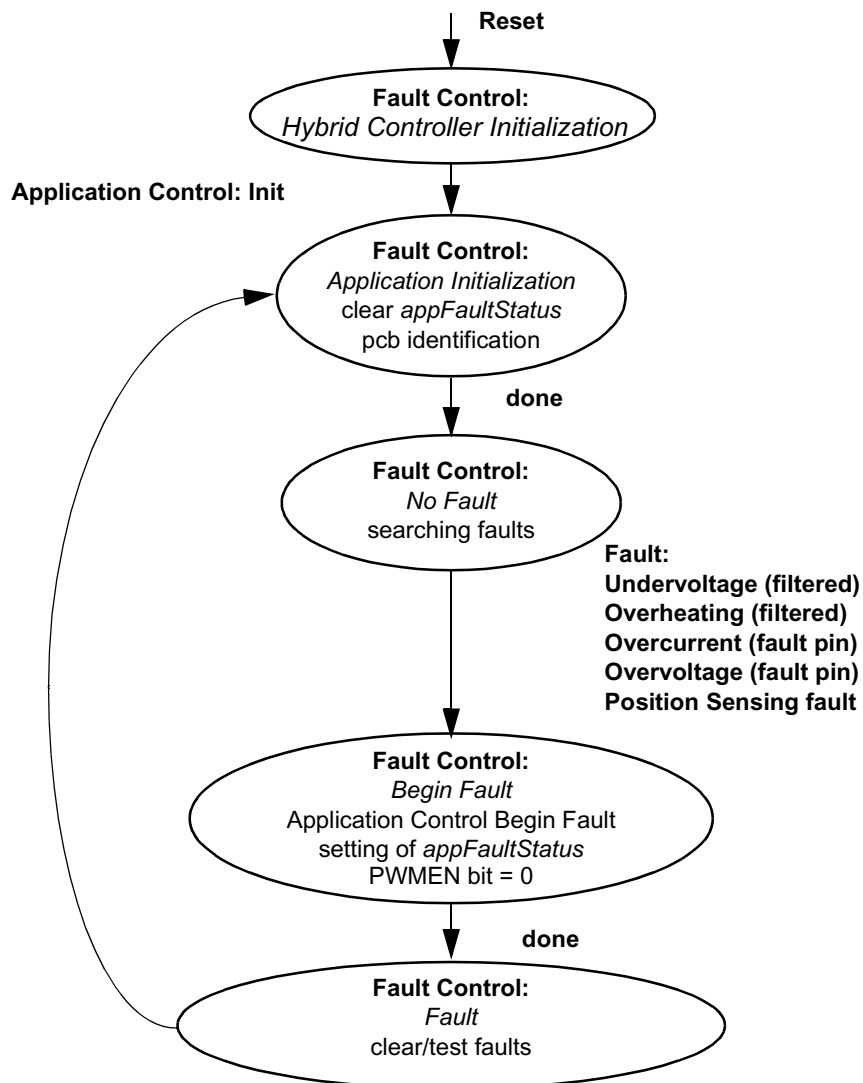
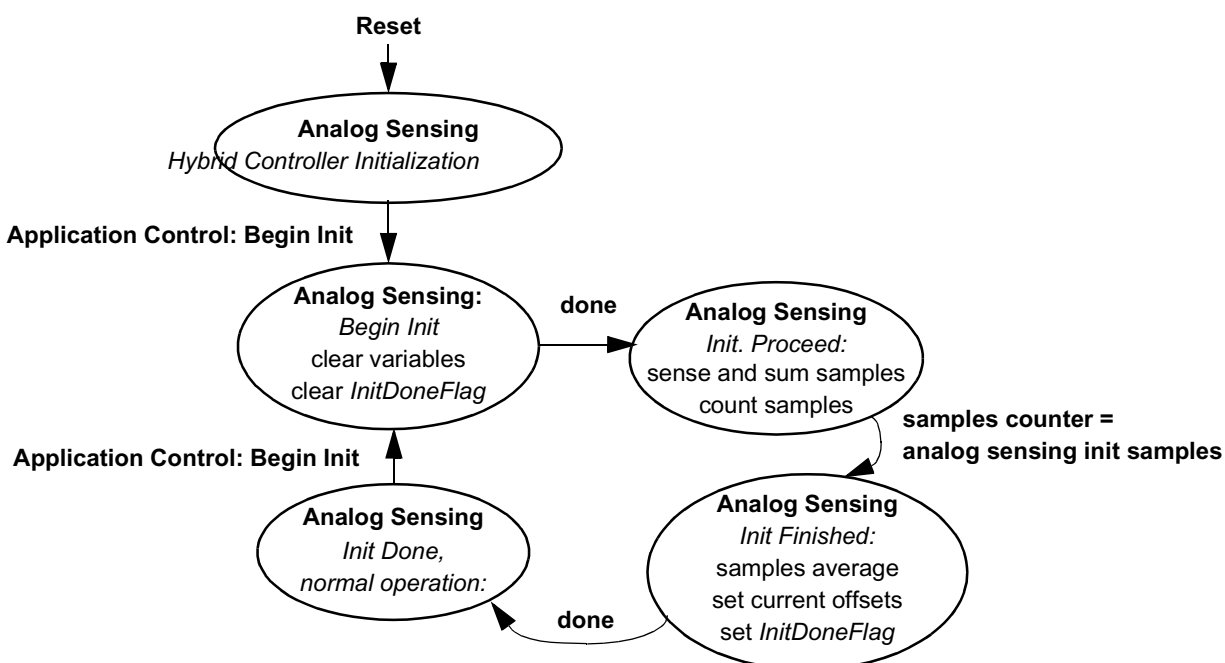

**Figure 6-11 State Diagram Fault Control**

### 6.3.5 Analog Sensing State Diagram

The state diagram of the Analog Sensing subprocess is shown in **Figure 6-12**. The Hybrid Controller Initialization state initializes hardware modules such as ADC, synchronization with PWM, etc. In *Begin Init*, Initialization is started, so the variables for initialization sum and the *InitDoneFlag* are cleared. In the *Init Proceed* state, the temperature, DCBus voltage and phase current samples are sensed and summed. After required analog sensing, *Init* samples are sensed, and the *Init Finished* state is entered. The samples' average is calculated from the sum divided by the number of analog sensing *Init* samples. According to the phase currents' average value, the phase current offsets are initialized.

All variable sensing is initialized and the state *Init Done* is entered, so the variables from analog sensing are valid for other processes. In this state, temperature and DCBus voltage are filtered in first order filters.



**Figure 6-12 State Diagram - Analog Sensing**

## 7. Implementation Notes

This section explains implementation notes for targeting a 56F83xxEVM.

### 7.1 Scaling of Quantities

The PMSM Vector Control application uses a fractional representation for all real quantities except time.

The N-bit signed fractional format is represented using 1.[N-1] format (1 sign bit, N-1 fractional bits). Signed fractional numbers (SF) lie in the following range:

$$-1.0 \leq \text{SF} \leq +1.0 \cdot 2^{-[N-1]} \quad \text{EQ. 7-1}$$

For words and long-word signed fractions, the most negative number that can be represented is -1.0, whose internal representation is \$8000 and \$80000000, respectively. The most positive word is \$7FFF or  $1.0 - 2^{-15}$ , and the most positive long-word is \$7FFFFFFF or  $1.0 - 2^{-31}$ .

The following equation shows the relationship between the real and fractional representations:

$$\text{Fractional Value} = \frac{\text{Real Value}}{\text{Real Quantity Range Max}} \quad \text{EQ. 7-2}$$

Where:

- Fractional Value* = The fractional representation of the real value [Frac16]
- Real Value* = The real value of the quantity [V, A, RPM, etc.]
- Real Quantity Range Max* = The maximum of the quantity range, defined in the application [V, A, RPM, etc.]

The C language standard does not have any fractional variable type defined. Therefore, fractional operations are provided by CodeWarrior intrinsics functions (e.g. *mult\_r()*). As a substitution for the fractional type variables, the application uses types Frac16 and Frac32. These are in fact defined as integer 16-bit signed variables and integer 32-bit signed variables. The difference between Frac16 and pure integer variables is that Frac16 and Frac32 declared variables should only be used with fractional operations (intrinsics functions).

A recalculation from real to a fractional form and Frac16, Frac32 value is made with the following equations:

$$\text{Frac16 Value} = 32768 \cdot \frac{\text{Real Value}}{\text{Real Quantity Range Max}} \quad \text{EQ. 7-3}$$

for Frac16 16-bit signed value and:

$$\text{Frac32 Value} = 2^{31} \cdot \frac{\text{Real Value}}{\text{Real Quantity Range Max}} \quad \text{EQ. 7-4}$$

for Frac32 32-bit signed value:

$$\text{Fractional Value} = \frac{\text{Real Value}}{\text{Real Quantity Range Max}} \quad \text{EQ. 7-5}$$

Fractional form, a conversion from Fraction Value to Frac16 and Frac32 Value, can be provided by the C language macro.

### 7.1.1 Voltage Scaling

Voltage scaling results from the sensing circuits of the hardware used; for details, see the **3-Phase AC BLDC High-Voltage Power Stage User's Manual**.

Voltage quantities are scaled to the maximum measurable voltage, which is dependent on the hardware. The relationship between real and fractional representations of voltage quantities is:

$$u_{Frac} = \frac{u_{Real}}{VOLT\_RANGE\_MAX} \quad \text{EQ. 7-6}$$

Where:

$u_{Frac}$	=	Fractional representation of voltage quantities [-]
$u_{Real}$	=	Real voltage quantities in physical units [V]
$VOLT\_RANGE\_MAX$	=	Defined voltage range maximum used for scaling in physical units [V]

In the application, the  $VOLT\_RANGE\_MAX$  value is the maximum measurable DCBus voltage:

$$VOLT\_RANGE\_MAX = 407V$$

All application voltage variables ( $u_{dc\_bus}$ ;  $u_{dc\_bus\_filt}$ ;  $u_{SAlphaBeta}$ ;  $u_{SDQ}$ ,  $u_{SAlphaBeta}$ ; and so on) are scaled in the same way.

## 7.1.2 Current Scaling

Current scaling also results from the sensing circuits of the hardware used; for details, see the **3-Phase AC BLDC High-Voltage Power Stage User's Manual**.

The relationship between real and fractional representation of current quantities is:

$$i_{Frac} = \frac{i_{Real}}{\int CURR\_RANGE\_MAX} \quad \text{EQ. 7-7}$$

Where:

$i_{Frac}$	=	Fractional representation of current quantities [-]
$i_{Real}$	=	Real current quantities in physical units [A]
$CURR\_RANGE\_MAX$	=	Defined current range maximum used for scaling in physical units [A]

In the application, the  $CURR\_RANGE\_MAX$  value is the maximum measurable current:

$$CURR\_RANGE\_MAX = 5.86A$$

All application current variables (components of  $i_{Sabc\_comp}$ ;  $i_{SAlphaBeta}$ ;  $i_{SDQ}$ ;  $i_{SDQ\_desired}$ ;  $i_{Sd\_Alignment}$ ; and so forth) are scaled in the same way.

**Notes:** As shown in **3-Phase AC BLDC High-Voltage Power Stage User's Manual**, the current sensing circuit provides measurement of the current in the range from  $CURR\_MIN = -2.93A$  to  $CURR\_MAX = +2.93A$ , giving the voltage for the ADC input ranges from 0 to 3.3V with 1.65V offset. The 56F80x's ADC converter is able to automatically cancel (subtract) the offset. The fractional representation of the measured current is then in the range  $<-0.5, 0.5$ , while the possible

representation of a fractional value is  $\in (-1,1)$ , as shown in [EQ. 7-3](#). Therefore,  $CURR\_RANGE\_MAX$  is calculated according to the following equation:

$$CURR\_RANGE\_MAX = CURR\_MAX - CURR\_MIN = 2 \cdot CURR\_MAX \quad \text{EQ. 7-8}$$

### 7.1.3 Speed Scaling

Speed quantities are scaled to the defined speed range maximum, which should be set lower than all speed variables in the application, so it was set higher than the maximum mechanical speed of the drive. The relationship between real and fractional representation of speed quantities is:

$$\omega_{Frac} = \frac{\omega_{Real}}{OMEGA\_RANGE\_MAX} \quad \text{EQ. 7-9}$$

where:

$\omega_{Frac}$	=	Fractional representation of speed quantities [-]
$\omega_{Real}$	=	Real speed quantities in physical units [rpm]
$OMEGA\_RANGE\_MAX$	=	Defined speed range maximum used for scaling in physical units [rpm]

In the application, the  $OMEGA\_RANGE\_MAX$  value is defined as:

$$OMEGA\_RANGE\_MAX = 6000 \text{rpm}$$

Other speed variables ( $\omega_{reqPCM\_mech}$ ;  $\omega_{desired\_mech}$ ;  $\omega_{required\_mech}$ ;  $\omega_{reqMAX\_mech}$ ;  $\omega_{reqMIN\_mech}$ ;  $\omega_{actual\_mech}$ ) are scaled in the same way

The relation between speed scaling and speed measurement with encoder is described in [Section 4.3.1.2](#). In the final software, the constant  $OMEGA\_SCALE$  is identical with the scaling constant  $k$  in equations [EQ. 4-1](#) and [EQ. 4-4](#), and  $OMEGA\_RANGE\_MAX$  is  $\omega_{Max}$ .

### 7.1.4 Position Scaling

Position Scaling is described in [Section 4.3.1.1](#)

### 7.1.5 Temperature Scaling

As shown in [Section 4.3.4](#), the temperature variable does not have a linear dependency.

## 7.2 PI Controller Tuning

The application consists of four PI controllers. Two controllers are used for the  $I_d$  and  $I_q$  currents, one for speed control and the other for field-weakening. The controller's constants are given by simulation in Matlab and were experimentally specified. A detailed description of controller tuning is beyond the scope of this application note.

### 7.3 Subprocesses Relation and State Transitions

As shown in [Section 6.2](#) and [Section 6.3](#), the software is split into subprocesses according to functionality. The application code is designed to be able to extract individual processes, such as Analog Sensing, and use them for customer applications. The C language functions dedicated for each process are located in one place in the software, so they can be easily used for other applications. Function naming usually starts with the name of the process, for example, *AnalogSensingInitProceed()*.

As [Section 6.3](#) shows, the processes' or subprocesses' state transients have some mutual relations. For example, "Application Control: Begin Initialization" is a condition for transient of the "Analog Sensing process: Init Done" to *Begin Init* state. In the code, the interface between processes is provided via "trigger" functions. The naming convention for these functions is: *<ProcessName><State>Trig()*.

The functionality is explained in following example:

The "trigger" function, *Process1StateTrig()*, is called from *process1*. The transient functions of *process2*, *process3*, etc., which must be triggered by *Process1State*, are put inside *Process1StateTrig()*.

### 7.4 RUN / STOP Switch and Button Control

The RUN / STOP switch is connected to the GPIOE5 pin. The state of the RUN / STOP switch can be read directly from the GPIO Data Register.

User buttons are also connected to GPIO pins. The state of buttons are read periodically from the GPIO Data Register. The EVM boards do not resolve button contact bouncing, which may occur while pushing and releasing the button, so this issue must be resolved by software.

The reading of buttons is masked by software methods. The following algorithm is used to check the state of the desired GPIO pins.

The level of a GPIO may be LOW or HIGH. When the button is pressed, the logical level LOW is applied on the GPIO pin and the scanning routine detects the low level and sets the corresponding *buttonStatus* bit; see [Figure 7-1](#). Due to contact bounces, the routine disables the scanning process and sets the debounce counter to a predefined value just after the low level is detected. The variable *buttonStatus* represents the interrupt flag. Using the 56F83xx's software timer, the *ButtonProcessingInterrupt* function is periodically called, as shown in [Figure 7-1](#). The function *ButtonProcessingInterrupt* decrements the debounce counter and if the counter is 0, the reading of GPIO pins is again enabled. The button press is checked by the *ButtonEdge* function; see [Figure 7-2](#). When the variable *buttonStatus* is set, the *ButtonEdge* function returns "1" and clears *buttonStatus*. When the variable *buttonStatus* is not set, the *ButtonEdge* function returns "0".

According to the *ButtonProcessing* calling period, the value of the debounce counter should be set close to 180ms. This value is sufficient to prevent multiple sets of *buttonStatus* bits, due to contact bounces.

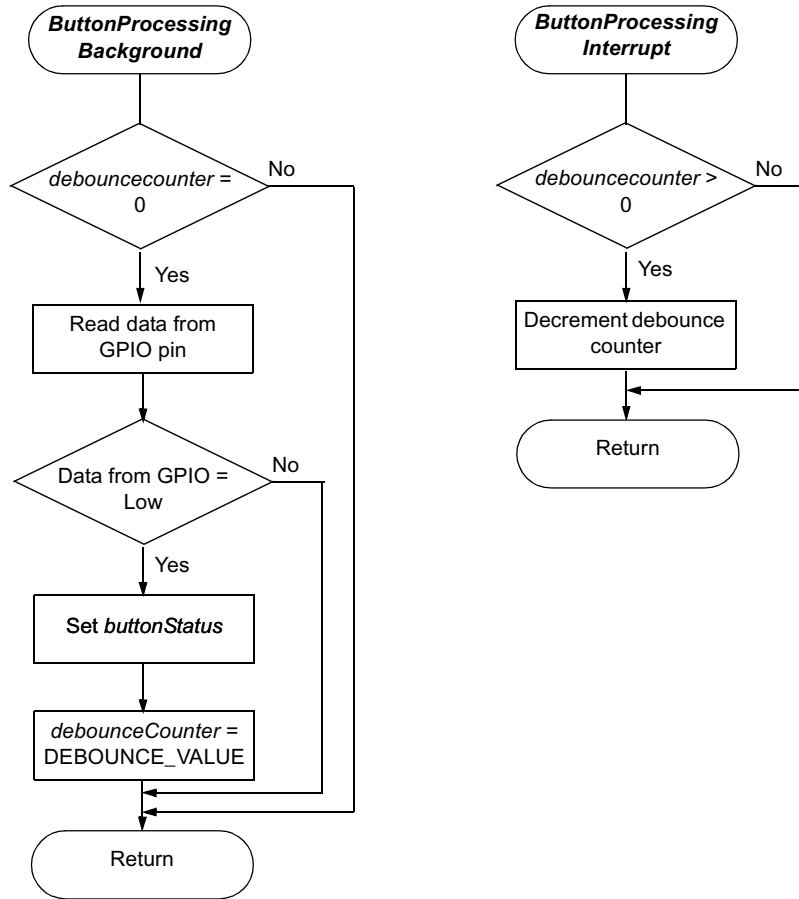

Figure 7-1 Button Control - *ButtonProcessingBackground* and *ButtonProcessingInterrupt*

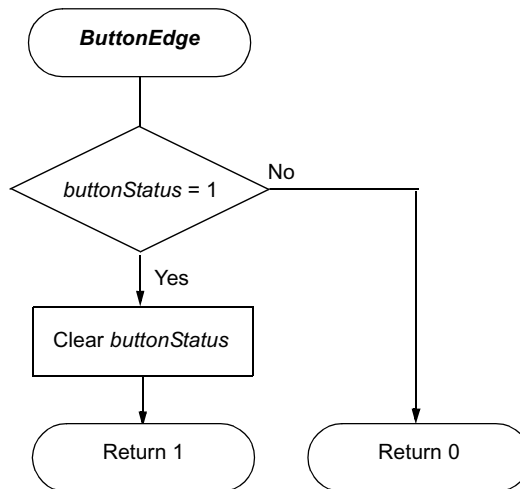

Figure 7-2 Button Control - *ButtonEdge*



## 8. Processor Expert (PE) Implementation

PE is a collection of beans; APIs; libraries; services; rules; and guidelines. This software infrastructure is designed to let a 56F80x or 56F8300 software developer create high-level, efficient, portable code. This chapter describes how the PMSM Vector Control application is written under PE.

### 8.1 Beans and Library Functions

The PMSM Vector Control application uses the following beans:

- ADC bean
- Quad Timer bean
- Quadrature Decoder bean
- PWM bean
- PC master software bean

The PMSM Vector Control application uses the following motor control functions:

- *cptrfmClarke* (Clarke transformation, *MC\_ClarkePark* bean)
- *cptrfmPark* (Park transformation, *MC\_ClarkePark* bean)
- *cptrfmParkInv* (Inverse Park transformation, *MC\_ClarkePark* bean)
- *mcElimDcBusRip* (DC bus ripple elimination, *MC\_SpaceVectorMod* bean)
- *mcPwmIct* (3-phase sinewave modulation, *MC\_SpaceVectorMod* bean)
- *rampGetValue* (ramp generation, *MC\_Ramp* library)
- *controllerPItype1\_asmSc* (PI controller, *MC\_Controller* bean)

### 8.2 Beans Initialization

Each peripheral on the hybrid controller or on the EVM board is accessible through a bean. This section describes the bean initialization of all peripherals used. For a more detailed description of drivers, see the **Targeting Freescale MC56F83xx Platform** manual.

To use a bean, follow these steps:

- Add the required bean:
  - Right click *Beans* under the *Processor Expert* tab in the project window and select *Add Beans*
  - When PE's *Bean Selector* window opens, select the desired bean
- Configure the added bean
- Call the bean's *init* function or use PE initialization, by selecting *Call init* in the CPU *init* code

Access to individual driver functions is provided from *PESL* support by the *ioctl* or *PESL* function call. To enable access to these functions, *PESL support* should be enabled in the *CPU bean* used.

### 8.3 Interrupts

When configuring a bean in PE, the user defines the callback functions called during interrupts.

## 8.4 PC Master Software

PC master software was designed to provide a debugging, diagnostic and demonstration tool for development of algorithms and applications. It consists of components running on PCs and components running on the target hybrid controller, connected by an RS-232 serial port. A small program is resident in the hybrid controller that communicates with the PC master software to parse commands, return status information to the PC, and process control information from the PC. The PC master software executing on a PC uses Microsoft Internet Explorer as a user interface to the PC.

To enable the PC master software operation on the hybrid controller target board application, add the *PC\_Master* bean to the application. The *PC\_Master* bean is located under *CPU External Devices -> Display* in PE's *Bean Selector*.

The PC master bean automatically includes the SCI driver and installs all necessary services. This means there is no need to install SCI driver because the *PC\_Master* bean encapsulates its own SCI driver.

The default baud rate of the SCI communication is 9600 and is set automatically by the PC master software driver.

A detailed PC master software description is provided in the PE documentation.

The 3-Phase PMSM Vector Control utilizes PC master software for remote control from a PC. It enables the user to:

- Control the PC master software
- Control the motor's Start / stop
- Set motor speed

Variables read by the PC master software as a default and displayed to the user are:

- Required motor speed
- Actual motor speed
- Application status
  - Init
  - Stop
  - Run
  - Fault
- DCBus voltage level
- Identified line voltage
- Fault Status
  - No\_Fault
  - Overvoltage
  - Overcurrent
  - Undervoltage
  - Overheating

The profiles of required and actual speeds, together with the desired  $I_d$  and  $I_q$  currents, can be seen in the Speed Scope window.

The course of quickly-changing variables can be observed in the Recorder windows, displayed by the PC master's Speed Scope. The Recorder can **only** be used when the application is running from **External RAM**, due to the limited on-chip memory. The length of the recorded window may be set in *Recorder Properties* => bookmark *Main* => *Recorded Samples*. The dedicated memory space is defined in the *appconfig.h* file of the ExtRAM target. The recorder samples are taken every 125µsec.

The following records can be captured:

- Required speed
- Actual speed
- Desired  $I_d$  current
- Desired  $I_q$  current

The PC master software Control Page is illustrated in **Figure 8-1**. The profiles of the required and actual speeds can be seen in the Speed Scope window.

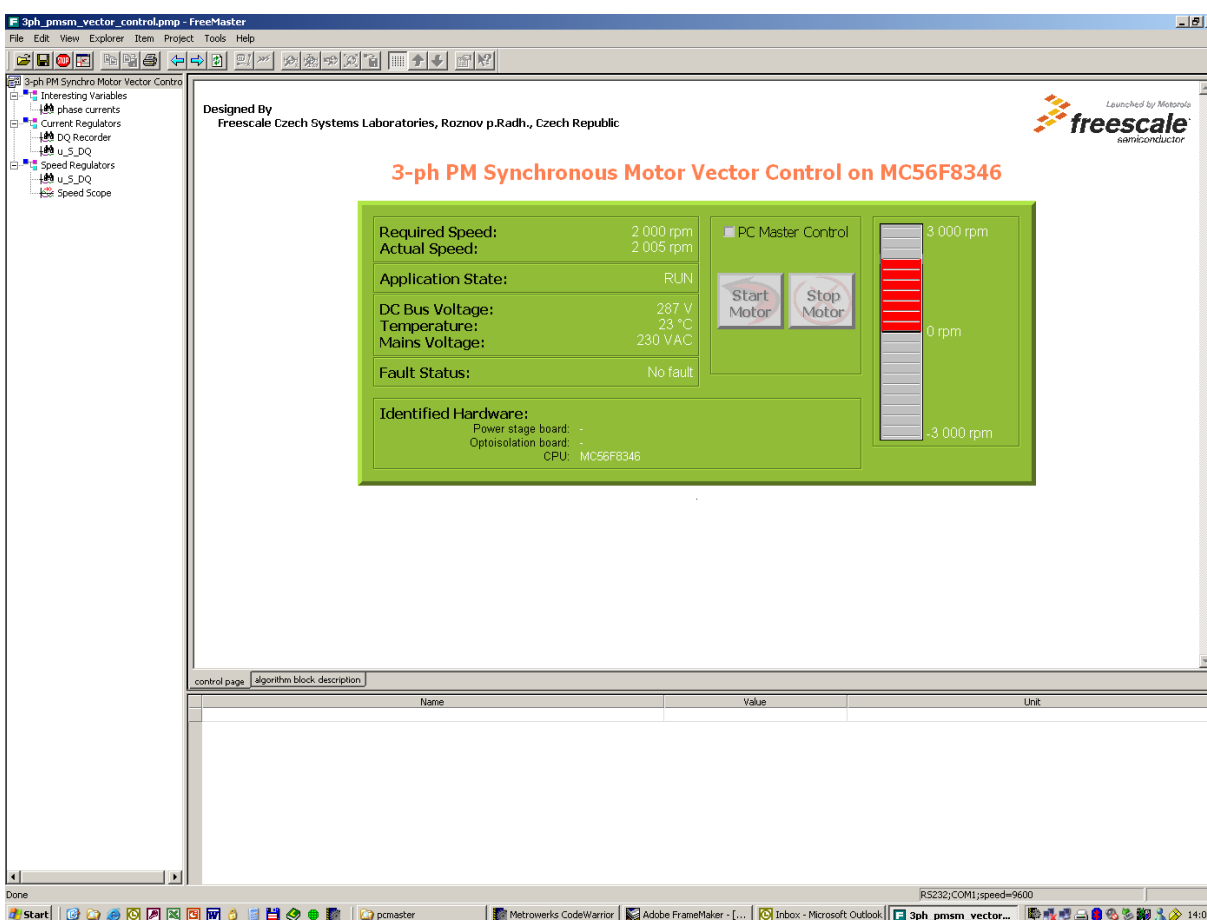

**Figure 8-1 PC Control Window**

## 9. Hybrid Controller Memory Use

**Table 9-1** shows how much memory is needed to run the 3-phase PMSM Vector Control drive using the Quadrature Encoder. A part of the hybrid controller memory is still available for other tasks.

**Table 9-1 RAM and FLASH Memory Use by PE 2.94 and CodeWarrior 6.1.2**

Memory (in 16-bit Words)	Available for 56F8300 Hybrid Controller	Application Used + Stack	Application Used without PC Master Software, SCI
Program Flash	64K	9009	4546
Data Flash	4K	4373	4360
Program RAM	2K	0	0
Data RAM	4K	2580 + 512 stack	396 + 512 stack

## 10. References

- [1] *Design of Brushless Permanent-magnet Motors*, J.R. Hendershot JR and T.J.E. Miller, Magna Physics Publishing and Clarendon Press, 1994
- [2] *Brushless DC Motor Control using the MC68HC708MC4*, AN1702, Freescale Semiconductor, Inc.
- [3] *56F80x Evaluation Module Hardware User's Manual*, DSP56F80xEVMUM, Freescale Semiconductor, Inc.
- [4] *3-Phase AC BLDC High-Voltage Power Stage User's Manual*, MEMC3PBLDCPSUM/D, Freescale Semiconductor, Inc.
- [5] *56800 Family Manual*, DSP56F800FM, Freescale Semiconductor, Inc.
- [6] *DSP56F800 User Manual*, DSP56F801-7UM, Freescale Semiconductor, Inc.
- [7] *56F8300 Peripheral User Manual*, MC56F8300UM, Freescale Semiconductor, Inc.
- [8] *56F805 Evaluation Module Hardware User's Manual*, DSP56F805EVMUM, Freescale Semiconductor, Inc.
- [9] *56F83xx Evaluation Module Hardware User's Manual* for the specific device being implemented, MC56F83xxEVMUM, Freescale Semiconductor, Inc.
- [10] *Evaluation Motor Board User's Manual*, MEMCEVMBUM/D, Freescale
- [11] *User Manual* for PC master software; see PE documentation
- [12] *Sensorless Vector and Direct Torque Control*, P. Vas (1998), Oxford University Press, ISBN 0-19-856465-1, New York.
- [13] *Elektrické pohony*, Caha, Z.; Cerny, M. (1990), SNTL, ISBN 80-03-00417-7, Praha.
- [14] *Freescale web page: [www.freescale.com](http://www.freescale.com)*







## **How to Reach Us:**

### **Home Page:**

www.freescale.com

### **E-mail:**

support@freescale.com

### **USA/Europe or Locations Not Listed:**

Freescale Semiconductor  
Technical Information Center, CH370  
1300 N. Alma School Road  
Chandler, Arizona 85224  
+1-800-521-6274 or +1-480-768-2130  
support@freescale.com

### **Europe, Middle East, and Africa:**

Freescale Halbleiter Deutschland GmbH  
Technical Information Center  
Schatzbogen 7  
81829 Muenchen, Germany  
+44 1296 380 456 (English)  
+46 8 52200080 (English)  
+49 89 92103 559 (German)  
+33 1 69 35 48 48 (French)  
support@freescale.com

### **Japan:**

Freescale Semiconductor Japan Ltd.  
Headquarters  
ARCO Tower 15F  
1-8-1, Shimo-Meguro, Meguro-ku,  
Tokyo 153-0064, Japan  
0120 191014 or +81 3 5437 9125  
support.japan@freescale.com

### **Asia/Pacific:**

Freescale Semiconductor Hong Kong Ltd.  
Technical Information Center  
2 Dai King Street  
Tai Po Industrial Estate  
Tai Po, N.T., Hong Kong  
+800 2666 8080  
support.asia@freescale.com

### **For Literature Requests Only:**

Freescale Semiconductor Literature Distribution Center  
P.O. Box 5405  
Denver, Colorado 80217  
1-800-441-2447 or 303-675-2140  
Fax: 303-675-2150  
LDCForFreescaleSemiconductor@hibbertgroup.com

Information in this document is provided solely to enable system and software implementers to use Freescale Semiconductor products. There are no express or implied copyright licenses granted hereunder to design or fabricate any integrated circuits or integrated circuits based on the information in this document.

Freescale Semiconductor reserves the right to make changes without further notice to any products herein. Freescale Semiconductor makes no warranty, representation or guarantee regarding the suitability of its products for any particular purpose, nor does Freescale Semiconductor assume any liability arising out of the application or use of any product or circuit, and specifically disclaims any and all liability, including without limitation consequential or incidental damages. "Typical" parameters that may be provided in Freescale Semiconductor data sheets and/or specifications can and do vary in different applications and actual performance may vary over time. All operating parameters, including "Typicals", must be validated for each customer application by customer's technical experts. Freescale Semiconductor does not convey any license under its patent rights nor the rights of others. Freescale Semiconductor products are not designed, intended, or authorized for use as components in systems intended for surgical implant into the body, or other applications intended to support or sustain life, or for any other application in which the failure of the Freescale Semiconductor product could create a situation where personal injury or death may occur. Should Buyer purchase or use Freescale Semiconductor products for any such unintended or unauthorized application, Buyer shall indemnify and hold Freescale Semiconductor and its officers, employees, subsidiaries, affiliates, and distributors harmless against all claims, costs, damages, and expenses, and reasonable attorney fees arising out of, directly or indirectly, any claim of personal injury or death associated with such unintended or unauthorized use, even if such claim alleges that Freescale Semiconductor was negligent regarding the design or manufacture of the part.



Freescale™ and the Freescale logo are trademarks of Freescale Semiconductor, Inc. All other product or service names are the property of their respective owners. This product incorporates SuperFlash® technology licensed from SST.

© Freescale Semiconductor, Inc. 2005. All rights reserved.