

* Some of the contents in this manual may differ from your phone, depending on the software installed or your service provider.



World Wide Web
<http://www.samsungmobile.com>

Printed in Korea
Code No. : GH68-05542A
English. 12/2004. Rev.1.0



PORTABLE CELLULAR TELEPHONE SCH-X839

User's Manual



Table of contents

Important safety precautions	7
Unpacking	9
Your phone	10
Phone layout	10
Display	13
Backlight	15
Service light	15
Camera	15
Flash	16
Getting started	17
Using a battery	17
Switching on or off the phone	20
Using the soft keys	22
Your phone's modes	23
Call functions	25
Making a call	25
Ending a call	26
Emergency dialing	26
Using the recent call logs	27
Making a call from Phone book	27
Prepend dialing	28
Speed dialing	29
Pause dialing	30
Adjusting the volume during a call	32
Answering a call	33
Silencing an incoming call	33
Viewing missed calls	34
Options during a call	34
Three-way calling	35
Call waiting	36
Call forwarding	36
Entering text	37
Changing the text input mode	37
Using T9 Hebrew, T9 English mode	38

Table of contents

Using Hebrew, English mode	40
Using Symbol mode	43
Using Number mode.....	43
Using the menus.....	44
Accessing a menu function by scrolling	44
Using shortcuts	45
List of menu functions	46
Calls	51
Missed (<i>Menu 1-1</i>).....	51
Incoming (<i>Menu 1-2</i>)	52
Outgoing (<i>Menu 1-3</i>).....	53
Air Time (<i>Menu 1-4</i>).....	53
Phone book.....	54
Find (<i>Menu 2-1</i>)	54
Add (<i>Menu 2-2</i>).....	57
Group Set (<i>Menu 2-3</i>)	62
My Phone # (<i>Menu 2-4</i>).....	62
Message	63
Text MSG (<i>Menu 3-1</i>).....	63
MMS (<i>Menu 3-2</i>).....	68
Voice Mail (<i>Menu 3-3</i>)	73
Msg Setup (<i>Menu 3-4</i>).....	74
Scheduler	77
Calendar (<i>Menu 4-1</i>).....	77
Alarm Set (<i>Menu 4-2</i>)	80
Set time (<i>Menu 4-3</i>)	81
Calculator (<i>Menu 4-4</i>)	83
Today (<i>Menu 4-5</i>).....	83
To Do List (<i>Menu 4-6</i>)	84
World time (<i>Menu 4-7</i>).....	85
Countdown (<i>Menu 4-8</i>).....	86
Memo pad (<i>Menu 4-9</i>).....	87
Games	88
Chicken run (<i>Menu 5-1</i>).....	89
Mobile cop (<i>Menu 5-2</i>)	89
Voice Tools	91

Table of contents

Voice Memo (<i>Menu 6-1</i>)	91
Voice Answer (<i>Menu 6-2</i>).....	93
Settings.....	96
Sounds (<i>Menu 7-1</i>).....	96
Display (<i>Menu 7-2</i>)	100
Auto retry (<i>Menu 7-3</i>).....	103
Answer mode (<i>Menu 7-4</i>)	103
Security (<i>Menu 7-5</i>).....	104
Data/Fax Mode (<i>Menu 7-6</i>).....	108
Memory status (<i>Menu 7-7</i>).....	109
VAS.....	110
Internet Portal (<i>Menu 8-1</i>).....	110
Games & App. (<i>Menu 8-2</i>)	114
Ringtone (<i>Menu 8-3</i>).....	116
Animation (<i>Menu 8-4</i>)	116
Voice Portal (<i>Menu 8-5</i>).....	117
SMS INFO (<i>Menu 8-6</i>).....	117
GPS (<i>Menu 8-7</i>)	118
What's new? (<i>Menu 8-8</i>).....	119
Camera.....	120
Take photo (<i>Menu 9-1</i>).....	120
Record video (<i>Menu 9-2</i>)	124
Photo album (<i>Menu 9-3</i>).....	126
Video album (<i>Menu 9-4</i>)	127
MMS (<i>Menu 9-5</i>).....	129
Settings (<i>Menu 9-6</i>).....	132
Memory status (<i>Menu 9-7</i>).....	132
Health and safety information	133
Exposure to radio frequency (RF) signals	133
For body operation.....	135
Precautions when using batteries	136
Road safety	137
Operating environment.....	138
Electronic devices	138
Potentially Explosive Environments	140
Emergency calls	141
Other important safety information	142
Care and maintenance.....	143
Glossary	145

Table of contents

Index.....	148
Quick reference card.....	151



Important safety precautions

Read these guidelines before using your wireless phone. Failure to comply with them may be dangerous or illegal.

Road safety at all times

Do not use a hand-held phone while driving; park the vehicle first.

Switching off when refuelling

Do not use the phone at a refuelling point (service station) or near fuels or chemicals.

Switching off in an aircraft

Wireless phones can cause interference. Using them in an aircraft is both illegal and dangerous.

Switching off in hospitals

Switch off your phone near medical equipment. Follow any regulations or rules in force.

Interference

All wireless phones may be subject to interference, which could affect their performance.

Special regulations

Meet any special regulations in force in any area and always switch off your phone whenever it is forbidden to use it, or when it may cause interference or danger (in a hospital for example).

Important safety precautions

Sensible use

Use only in the normal position (held to the ear). Avoid unnecessary contact with the antenna when the phone is switched on.

Emergency call

Ensure the phone is switched on and in service. Key in the emergency number for your present location, then press the  key. You must deactivate any unnecessary features in use before you can make an emergency call. Give all necessary information as accurately as possible. Do not end the call until given permission to do so.

Water resistance

Your phone is not water-resistant. Keep it dry.

Accessories and batteries

Use only Samsung-approved accessories and batteries. Use of any unauthorized accessories could damage your phone and may be dangerous.

Qualified service

Only qualified service personnel may repair your phone.

For more detailed safety information, see "Health and safety information" on page 133.

CAUTION

RISK OF EXPLOSION IF A BATTERY IS REPLACED
BY AN INCORRECT TYPE.
DISPOSE OF USED BATTERIES ACCORDING TO
THE INSTRUCTIONS.

Unpacking

Your package contains the following items. The illustrations below may look different from your phone and accessories:



Handset



Travel adapter



Battery



Necklace headset

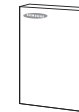

User's manual



Hand strap

Your phone

Phone layout



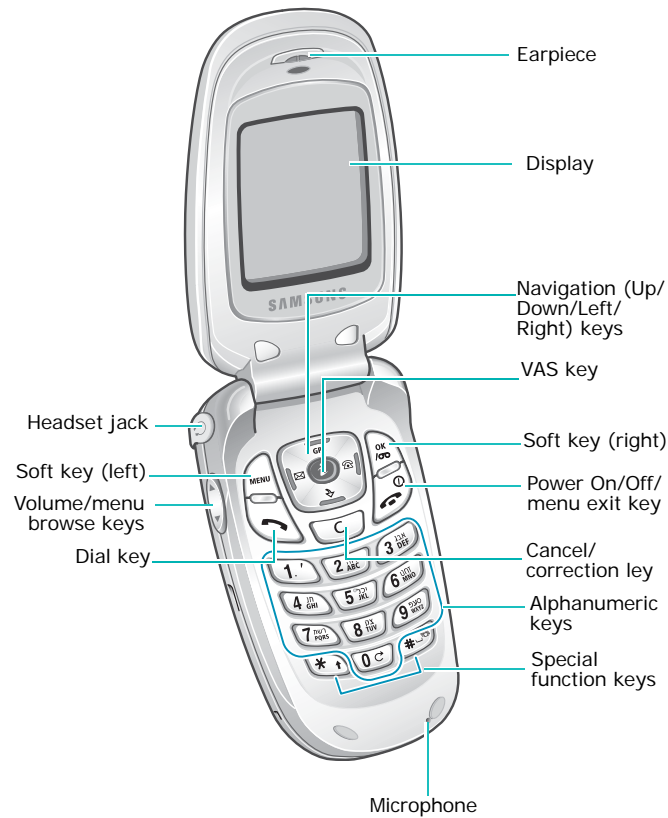

The following illustrations show the main elements of your phone:



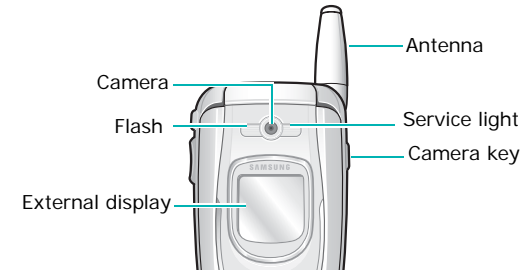



With the phone open



With the phone closed



Key(s)	Description
 (soft keys)	Performs the functions indicated by the screen text above them, on the bottom line of the display.
	In Menu mode, scrolls through menu options. In Standby mode; quickly enters the following menu respectively: <ul style="list-style-type: none"> • Up: GPS • Down: Games & App. • Left: Message • Right: Find in the Phone book menu.
	Enters the VAS menu.
	Makes or answers a call. In Standby mode, retrieves the most recent numbers dialed, received, or missed. Redials the last number when pressed and held.





Key(s)	Description (continued)
	Ends a call. Also switches the phone on and off when pressed and held. In Menu mode, cancels your input and returns to Standby mode.
	Deletes characters from the display. In Menu mode, returns you to the previous menu level.
	Enters numbers, letters, and some special characters.
	In the text entry mode, changes the case of letters.
	In Standby mode, quickly enters or exits Silent mode when pressed and held. In the text entry mode, inserts a space.
	(on the right side of the phone) Allows you to quickly access the Camera menu. Turns on the camera when pressed and held.
	(on the left side of the phone) During a call, adjust the voice volume. In Standby mode, adjusts the Key tone volume.

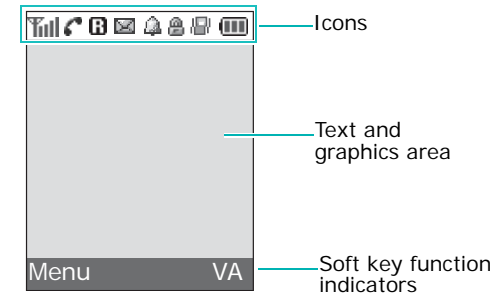







Display

The display has three areas: the top line of icons, the text and graphic area, and the bottom line of soft key indicators.



Icons

Icon	Description
	Signal strength: Shows the received signal strength. The greater the number of bars, the better the signal.
	Service: Appears when a call is in progress.
	No service: Appears when you are outside a service area. When it displays, you cannot make or receive calls. Wait a little while for a better signal or move into an open area to regain service.
	Roaming: Appears when you are out of your home area and have logged onto a different network; for example, when traveling in other countries.

Icon	Description (continued)
	Alarm mode: Appears when you set an alarm to ring at a specified time.
	New message: Indicates that there is a new message waiting to be checked.
	New voice mail message: Indicates that there is a new voice mail message waiting to be checked.
	Vibration mode: Appears when the ringer volume for call is set to Vibrate or when your phone is in Silent mode.
	Restriction on: Appears when any option of the Restriction feature is activated.
	Lock mode: Appears when your phone is locked.
	Ringer silent: Appears when the ringer volume for calls is set to No tone .
	Battery status: Shows the level of your battery. The more bars you see, the more power you have remaining.

External display

Your phone has an external display on the phone. When you close the phone, it turns on and indicates when you have an incoming call or a message. It also alerts you at the specified time when you have set an alarm by turning its backlight and showing the corresponding icon on it.

When the display is off, press and hold one of the Volume keys on the left side of the phone to turn on the display.

Backlight

The backlight illuminates the display and keypad. When you press any key or open the phone, the backlight illuminates. It turns off if no key is pressed within a given period of time, depending on the **Backlight** menu (**Menu 7-2-3**) set in the **Display** menu.

To specify the length of time the phone waits before the backlight turns off, set the **Backlight** menu. See page 102 for further details.

Service light

The service light on the front of the phone, on the right side of the camera, flashes to indicate an incoming call, message, or alarm and flashes for a few seconds when you turn on or off the phone. It blinks while the battery is charging with the travel adapter; the color of the light turns green when the battery is fully charged.

Camera

The camera module on the front of the phone allows you to take a photo or record a video while on the move.

For further details about the Camera feature, see page 120.

Flash

You can use the built-in flash on the front of the phone, on the left side of the camera, to take photos when it is dark.

Getting started

Using a battery

Your phone is powered by a rechargeable Li-ion battery. Use only approved batteries and chargers. Ask your local Samsung dealer for further details.

Note: You must fully charge the battery before using your phone for the first time. A discharged battery recharges fully in approximately 200 minutes for a standard battery.

Installing the battery

1. Place the battery so that the tabs on the end align with the slots at the bottom of the phone.

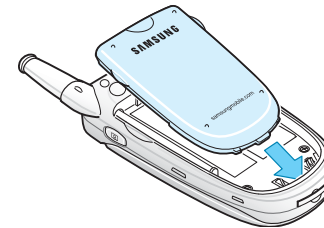

2. Press the battery until it clicks into place.

Make sure that the battery is properly installed before switching on the phone.

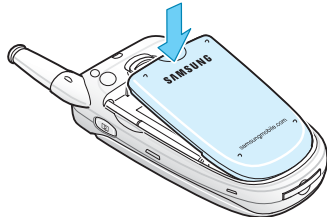

Removing the battery

1. If necessary, switch off the phone by pressing and holding the  key down until the power-off image displays.
2. To remove the battery. To do so:
 - ① Slide the battery lock towards the top of the phone.
 - ② Lift away the battery, as shown.

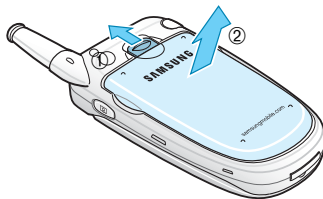

Charging the battery

A travel adapter and a battery charger are provided for charging your batteries.

Using the travel adapter

The travel adapter allows you to use the phone while the battery is charging, but this will cause the battery to charge more slowly.

1. With the battery in position on the phone, plug the connector of the travel adapter into the jack at the bottom of the phone.

Make sure that the arrow on the connector is facing toward the front of the phone.

2. Plug the adapter into a standard AC wall outlet.

The battery strength icon on the display shows that the battery is charging.

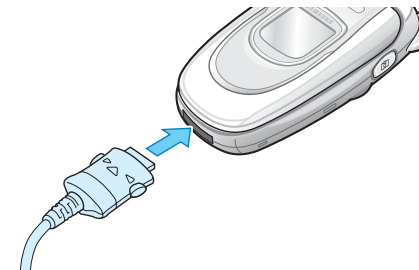

- When charging is finished, unplug the adapter from both the power outlet and the phone by pressing the buttons on both sides of the connector and pulling the connector out.

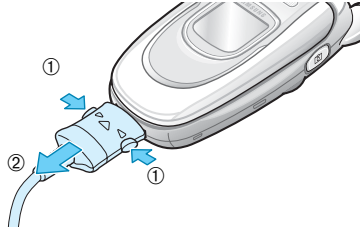

Note: Do not remove the battery from the phone without unplugging the adapter while it is charging. Otherwise, the phone may be damaged.

Low battery indicator

When the battery is weak and only a few minutes of talk time remain, the battery sensor will let you know by blinking the empty Battery Strength icon (☐) and you will hear a warning tone and a "LOW BATTERY WARNING!" message will be repeated at regular intervals on the display. When the battery becomes too weak for the phone to operate, it switches off automatically.

Switching on or off the phone

- Open the phone.
- Press and hold the  key for more than one second to switch on the phone.

- The service light flashes and then the idle screen appears on the display when the system locates services.

If the phone is out of the service area, the No Service icon (📶) appears on the display. In this case, you cannot place and receive calls. You can try again later when service is available.

Note: You can change the display language in the **Language/ⓂⓂⓂ** menu (**Menu 7-2-6**). See page 102.



- When you wish to switch off the phone, press and hold the  key for more than one seconds until the power-off image displays.

WARNING!

Do not switch on the phone when mobile phone use is prohibited or when it may cause interference or danger.

Note: Do not touch the antenna on the phone unnecessarily when the phone is switched on. Contact with the antenna affects the call quality and may cause the phone to operate at a higher power level than otherwise needed.

Using the soft keys

Your phone offers a set of functions that allows you to customize it. These functions are arranged in menus and submenus, accessed using the two soft keys,  and . Each menu and submenu allows you to view and alter the settings of a particular function.

The roles of the soft keys vary, depending on the current function you are using; the labels on the bottom line of the display just above each key indicate their current role.

Example:







Press the left soft key to access Menu mode.

Press the right soft key to access the **Voice Answer** menu.

Your phone's modes

Standby mode

Standby mode is the most basic state of your phone. The phone goes into Standby mode soon after you turn it on, or whenever you briefly press the  key. When your phone is in Standby mode, you will typically see the current time and date. If you enter a phone number, you can press the  key to dial it, or press the **Save** soft key to save it in the internal Phone book.

Press the  key at any time to return to Standby mode. Be careful; if you are on a call when you press the  key, your phone disconnects the call and returns to Standby mode. Press the **C** key several times or hold it to return to Standby mode without ending the call.

Talk mode

You can place and answer calls only when your phone is turned on. During a call, the phone is in Talk mode. While you are in Talk mode, pressing the **Menu** soft key gives you a list of options. See page 34 for details on the options.

Power Save mode

Your phone comes with a power save feature that will automatically be activated if your phone is unable to find a signal after 15 minutes of searching. While this feature is active, the phone's battery charge is conserved. To return to Standby mode, press any key.

Lock mode

When you lock your phone using the **Phone lock** menu (**Menu 7-5-1**), you can receive messages and calls, but you cannot place a call until you unlock the phone.

To unlock the phone, press one of the soft keys, one of volume keys, one of the navigation keys, Camera key, VAS key or  key and enter the 4-digit lock code. The phone is immediately unlocked.

For further details about locking and unlocking the phone, see page 104.

Silent mode

Silent mode disables all sounds. This feature is best used in situations where the phone might disturb others, such as in a meeting, a library, and a theater.

To enter Silent mode, press and hold the **#** key until "Entering Silent Mode" and the Silent mode icon () appears.

To exit and reactive the previous sound settings, press and hold the **#** key until "Exiting Silent Mode" appears. The Silent mode icon no longer displays.

Note: If you turn off the phone in Silent mode, the Silent mode is still activated when you turn on the phone.

Call functions

Making a call

To make a call:

1. In Standby mode, enter the area code, and phone number.

While entering a phone number, press the **Pause** soft key to insert a hard pause. For more information on pause dialing, see page 30.

2. Press the  key. The phone places the call to the entered phone number.

Note: If you have set the time interval for automatic redialing in the **Auto retry** menu (**Menu 7-3**), the phone will automatically retry to make the call when no one answers or the line is busy. See page 103 for further details.

Correcting the number

To clear	Press the
the last digit displayed	C key.
the whole display	C key for more than one second.

Ending a call

When you want to finish your call, press the  key.

The call time, the length of the call, displays along with the phone number of the called person. If the number is stored in your Phone book, the name displays. If there is no match, you can press the **Save** soft key and store the number in Phone book. For further details about storing the number in Phone book, see page 57.

Alternatively, simply close the phone to end a call.







Emergency dialing

You can place emergency calls from your emergency numbers list, even if your phone is locked or all outgoing calls are restricted. For further details on emergency numbers, see page 105.

Using the recent call logs

The phone stores up to 90 of the calls dialed, received, or missed chronologically. The last call is saved in the first position.

To recall any of these numbers:

1. If there are any characters on the display, return to Standby mode by pressing the  key.
2. Press the  key. The list of recent calls displays.
 - : Outgoing calls
 - : Incoming calls
 - : Missed calls
3. Press the Up and Down keys, or the Volume keys on the left side of the phone to scan through the list until the number you want highlights.
4. Press  to dial the highlighted number.

Making a call from Phone book

You can store the phone numbers regularly in memory, which is called the Phone book. You then simply recall the number to dial. For further details on Phone book, see page 54.

Prepend dialing

The Prepend option lets you add digits, such as area codes and network feature activation codes, to a phone number that is in your call logs before dialing it.

To prepend the phone numbers stored in the call logs:

1. Access a call log in the Recent Calls list referring to page 27 or in the **Calls** menu (**Menu 1**).
2. When the phone number you want to dial highlights, press the **Select** soft key.
The display shows the details of the number.
3. Press the **Menu** soft key to access the Menu pop-up list.
4. Press the **3** key to select the **Prepend** option.
5. Enter the area code or feature code.
6. Press the  key to dial the number.

Speed dialing

Once you have stored phone numbers in Phone book, you can dial them easily with the few presses of the keys.

One-touch dial: Memory locations 0001 through 0009 are special one-touch locations. You can dial the phone numbers stored in the Phone book memory from 0001 through 0009 simply by pressing one key.

Press and hold the fourth digit of the memory location containing the number to be dialed.

For example: Location no. 0009
Press the **9** key and hold.

The number (and name) stored displays, then dials.

Two-touch dial: For memory locations of two digits.

Press the third digit briefly, then hold down the fourth digit of the memory cell.

For example: Location no. 0023
Press the **2** key briefly and hold down the **3** key.

The number (and name) stored displays, then dials.

Three-touch dial: For memory locations of three digits.

Press the second and third digits briefly, then hold down the fourth digit of the memory cell.

For example: Location no. 0123
Press the **1** and **2** key briefly and hold down the **3** key.

The number (and name) stored displays, then dials.

Pause dialing

When you call an automated system, like a banking service, you are often required to enter a password or an account number. Instead of manually entering the numbers each time, you can store the numbers in your Phone book, separated by pauses.

Storing pauses in a Phone book entry

To store a number in your Phone book that contains pauses:

1. Enter the phone number you want to store, such as a bank's teleservice phone number.
2. Press the **Pause** soft key to insert a pause. A "P" displays, meaning that a hard pause will occur at that point in the dialing sequence.

The "P" stops the dialing and waits for the teleservice to prompt you for a number. The number following the "P" is your account number, etc.

3. Enter the digits that need to follow the pause, such as your account number.
4. Repeat steps 2 and 3 to add more pauses and numbers, if necessary.
5. Store the number in your Phone book as you normally would by pressing the **Save** soft key and following from step 4 on page 57.



Pause dialing from a stored Phone book entry

1. Call the number from Phone book.
2. Wait for the appropriate prompt from the number you are calling.
3. When prompted, press the  key to send the DTMF (Dual Tone Multi Frequency) number that follows your pause.

"SENDING DTMF" flashes on the display and the transmitted tone sounds.

Manual pause dialing

You can enter pauses manually during the dialing process.

1. Enter the phone number of the service you want to call, such as a bank's teleservice phone number.
2. Press the **Pause** soft key to insert a pause.
The screen displays a "P" indicating a pause.
3. Enter the number to be sent after the pause by pressing the digit keys, and then press the  key.
4. After connecting, wait for the prompt from teleservice. Press the  key again after the prompt to send the additional number.

Adjusting the volume during a call

During a call, if you want to adjust the voice volume, use the Volume keys on the left side of the phone.

Press the ▲ key to increase the volume level and the ▼ key to decrease the level. The image on the display shows all five levels; the more bars you see, the higher the level is.





In Standby mode, you can also adjust the key tone volume using these keys.

Answering a call

When somebody calls you, the phone alerts you by ringing and blinking the service light.

If the caller can be identified, the caller's phone number or name, if stored in your Phone book, displays.

There are many ways to answer a call, depending on your setting in the **Answer mode** menu (**Menu 7-4**);

Setting option	To answer the call,
By send key	press the  key.
By folder open	open the phone. If it is already open, press the  key.
By any key	press any key except the soft keys, the  key or the Volume key.

To end the call, close the phone or press the  key.



Note: You can answer a call while using Phone book or menu features. The current operation stops.

Silencing an incoming call

You can silence the ringer when a call comes. Press one of the Volume keys when the phone is closed. If it is open, press the left soft key.

Viewing missed calls

If you fail to answer a call for any reason, the phone indicates a missed call by displaying a text notification on the screen. Additionally, if caller information is available, a Missed entry is created, and the screen displays the phone number of the last missed call.

When the display informs you of the missed call, press the  key to call the displayed number, or the  key to clear the message and return to Standby mode.

To view the list of the missed calls, refer to “Missed” on page 51.

Options during a call

Your phone provides a number of functions that you can use during a call. As many of these options are network services, you may not be able to use all of them at all times.

Press the **Menu** soft key during a call to access the following options:

Mute/Quit: allows you to switch your phone's microphone off, so that the other person cannot hear you.

Example: You wish to say something to another person in the room, but do not want the other person to hear you.

Calls: allows you to access the **Calls** menu. See page 51.

Phone book: allows you to access the **Phone book** menu. See page 54.

Silent/Quit: does not transmit the key tones. It allows you to press keys without hearing annoying key tones during a call.



Send My #: sends your phone number to the calling person or automated services.

DTMF Length: manipulates the audible DTMF (Dual-Tone Multi-Frequency) tones. You can choose either **long** or **normal**.

Three-way calling

This feature enables you to conduct conference calls with two separate people at the same time. The phone records both calls in the Outgoing call log. You are billed airtime for each of the outgoing calls separately. Contact your service provider to activate Three-Way Calling.

To make a three-way call:

1. During a conversation, enter the phone number for the third person and press the  key.
2. When the third person answers, press the  key again to begin your three-way call.

During a three-way call, if one of the callers hangs up, you and the remaining caller will stay connected. If you initiated the call and you hang up first, all calls are disconnected.

Call waiting

Call waiting lets you receive a second call during conversation. Your phone notifies you of a call waiting by beeping and displaying "Call Waiting."

Note: Contact your service provider to activate the Call waiting service.

To answer a waiting call:

To answer the call, press . The phone connects the calling party, and places the current party on hold.

Press  again to switch between two parties.

Note: If you do not respond to a Call waiting notification, the phone will forward the call to voicemail or another number that you have set up. Contact your service provider for more information.

Call forwarding

This feature provides the option of forwarding incoming calls to another phone number, even while your phone is off. Activating call forwarding does not affect outgoing calls made from this phone. Contact your service provider to activate call forwarding.

Entering text

At many times when using your phone, you will need to enter text; for example, when storing a name in Phone book, writing a text message, or scheduling events in your calendar. You can enter alphanumeric characters into your phone by using your phone's keypad.

Your phone has the following text input modes:

- **T9 Hebrew:** allows you to enter Hebrew letters using the T9 input method.
- **Hebrew:** allows you to enter Hebrew letters as you would in English mode.
- **T9 English:** allows you to enter English characters with only one keypress per character.
- **English:** allows you to enter English characters by pressing the key labeled with the character you want until it displays.
- **Symbol:** allows you to enter many different symbols and special characters.
- **Number:** allows you to enter numbers.

Note: Not in Number mode, To enter a number, press and hold down the corresponding key.

Changing the text input mode

Example: Writing a text message

In the text entry screen, press the **Mode** soft key.

1. Scroll to the mode you want by pressing the Navigation keys.

Note: If you want to exit the Mode list without changing to a new mode, press the **C** key.

Entering text

You can change between **T9 Hebrew**, **Hebrew**, **T9 English**, **English** and **Number** mode to enter words. To include a symbol between characters, **Symbol** mode is also available.

2. To select the highlighted mode, press the **Select** soft key.

You will find the selected text input mode indicator on the display.

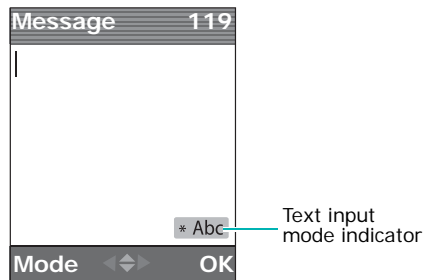

Using T9 Hebrew, T9 English mode

To type a word, press the keys corresponding to the letters you need. Remember the following as you are typing:

1. Press keys on the phone just once per letter. For example, to enter "Hello," press the **4**, **3**, **5**, **5**, and **6** keys.
2. The word you are typing appears on the display. It may change with each key press.
3. Type to the end of the word before editing or deleting any keystrokes.

Entering text

If the word does not display correctly, press the **0** key once or repeatedly to display alternative word choices for the keys you have typed.

For example, both "of" and "me" have the sequence of the **6** and **3** keys. The phone displays the most commonly used choice first.

4. Insert a space between words by pressing the **#** key.

Smart punctuation

You can insert periods, hyphens, and apostrophes by pressing the **1** key. T9 English applies rules of grammar to insert the correct punctuation. Notice that **1** key is used twice in this example to display two punctuation marks:

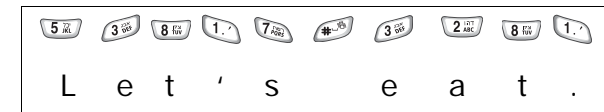

Changing the letter-case

Note: This feature is available only in T9 English mode.

To shift case of the next letter(s) that you type, press the ***** key. There are three cases:

- Initial Capital (**T9Word**)
- Capitals Lock (**T9WORD**)
- Lower Case (**T9word**)

Including a number

You can include a number between letters without exiting T9 English mode. Press and hold the corresponding number key.

Scrolling

To move the cursor to the left or right through your text, press the Left or Right key.

Clearing letters and words

Press the **C** key once or repeatedly to clear letters one by one to the left. Press and hold the **C** key to erase all of the letters on the display.

Using Hebrew, English mode

When typing in **Hebrew** and **English** mode, you should press the key labeled with the letter you want:

- once for the first letter
- twice for the second letter
- and so on.

This method is called Multi-tap typing.

For example, you need to press the **2** key three times quickly to display the letter "C" and the **5** key two times quickly to display the letter "K."

Refer to the table below for the list of characters assigned to each key.

List of characters available:

key	Characters in the Order Displayed
1 .	. @ , : ? - ; ' / () ! # % &
2 127 ABC	* < > _ + = " \ { } \$ [] 1 A B C 2 2 ך ם ן ן
3 DEF	D E F 3 3 ן ן ן ן
4 GHI	G H I 4 4 ן ן ן
5 JKL	J K L 5 5 ן ן ן
6 MNO	M N O 6 6 ן ן ן
7 PQRS	P Q R S 7 7 ן ן ן ן
8 TUV	T U V 8 8 ן ן ן
9 WXYZ	W X Y Z 9 9 ן ן ן ן
0 C	O 0

(Capital Lock)

The cursor moves to the right when you press a different key. When entering the same letter twice or a different letter on the same key, just wait for about four seconds, and enter the next letter.

Changing the letter-case

Note: This feature is available only in Alphabet mode.

To shift case of the next letter(s) that you type, press the ✖ key. There are three cases:

- Initial Capital (**Abc**)
- Capitals Lock (**ABC**)
- Lower Case (**abc**)

Inserting a space

Press the **#** key to insert a space between words.

Including a number

You can quickly include a number between letters. Press and hold the corresponding number key.

Scrolling

To move the cursor to the left or right through your text message, press the Left or Right key.

Clearing letters and words

Press the **C** key once or repeatedly to clear letters one by one to the left. Press and hold the **C** key to erase all of the letters on the display.

Using Symbol mode

Symbol mode enables you to enter symbols into your text.

Press the Left or Right key to display more symbol sets.

Press the keys corresponding to the mark you want, and manually switch back to the text entry mode of your choice. See page 37 for changing the text input mode.

Using Number mode

Number mode enables you to enter numbers into your text. Press the keys corresponding to the digits you want, and manually switch back to the text entry mode of your choice. See page 37 for changing the text input mode.

Using the menus

The phone offers a range of functions that allows you to tailor it to your needs. These functions are arranged in menus and submenus.

The menus and submenus can be accessed by scrolling or using the shortcuts.

Accessing a menu function by scrolling

1. In Standby mode, press the **Menu** soft key to access the main menu mode.
2. Scroll using the Navigation keys to reach a main menu, for example, **Settings**. Press the **Select** soft key to enter the menu.
3. Find the menu option you want, for example, **Display**, by scrolling using the Up or Down key. Press the **Select** soft key to enter the menu option.

If the menu you have selected contains submenus, such as **Language/הצגה**, repeat this step.

4. Scroll using the Navigation keys to select the setting of your choice.
5. Press the **Save** soft key to confirm the chosen setting.

Notes:

- To return to the previous menu level, press the **C** key.
- You can exit the menu without changing the menu settings by pressing the  key.

Using shortcuts

The menu items, such as menus, submenus, and setting options, are numbered and can be accessed quickly by using their shortcut numbers.

Note: The numbers assigned to each menu function are indicated on the list on page 46.

1. In Standby mode, press the **Menu** soft key to access the menu mode.
2. Enter the first digit of the shortcut number. Repeat this for each digit of the shortcut number.

Example: Changing the display language

Press the **7**, **2**, and **6** keys.

7 enters **Settings**, **2** selects **Display**, and **6** selects **Language/הצגה**.

3. Scroll using the Navigation keys to select the setting of your choice.
4. Press the **Save** soft key to confirm the chosen setting.

List of menu functions

The following list shows the menu structure and indicates the number assigned to each option.

1. Calls (see page 51)

- 1.1 Missed
- 1.2 Incoming
- 1.3 Outgoing
- 1.4 Air Time
 - 1.4.1 Last Call
 - 1.4.2 Total
 - 1.4.3 Life Time
 - 1.4.4 Erase Total

2. Phone book (see page 54)

- 2.1 Find
- 2.2 Add
- 2.3 Group Set
- 2.4 My Phone #

3. Message (see page 63)

- 3.1 Text MSG
 - 3.1.1 New Message
 - 3.1.2 Inbox
 - 3.1.3 Outbox
 - 3.1.4 Saved Msg
- 3.2 MMS
 - 3.2.1 New Message
 - 3.2.2 Inbox
 - 3.2.3 Outbox
 - 3.2.4 Draftbox
 - 3.2.5 MMS Alert
- 3.3 Voice Mail
- 3.4 Msg Setup
 - 3.4.1 Scroll Timer
 - 3.4.2 Msg. Reminder
 - 3.4.3 Alert on call
 - 3.4.4 SMS Message
 - 3.4.5 MMS Message
 - 3.4.6 Msg. Templates

4. Scheduler (see page 77)

- 4.1 Calendar
- 4.2 Alarm Set
- 4.3 Set time
 - 4.3.1 Main clock
 - 4.3.2 Dual clock
- 4.4 Calculator
- 4.5 Today
- 4.6 To Do List
- 4.7 World time
- 4.8 Countdown
- 4.9 Memo pad

5. Games (see page 88)

- 5.1 Chicken run
- 5.2 Mobile cop

6. Voice Tools (see page 91)

- 6.1 Voice Memo
 - 6.1.1 Record
 - 6.1.2 Review
- 6.2 Voice Answer
 - 6.2.1 On/Off
 - 6.2.2 Voice Messages
 - 6.2.3 Setting
 - 6.2.3.1 Greeting
 - 6.2.3.2 Screening
 - 6.2.3.3 Wait Time

7. Settings (see page 96)

- 7.1 Sounds
 - 7.1.1 Ringer
 - 7.1.1.1 Voice calls
 - 7.1.1.2 Messages
 - 7.1.1.3 Alarm/Scheduler
 - 7.1.2 Ringer Volume
 - 7.1.2.1 Voice calls
 - 7.1.2.2 Messages
 - 7.1.2.3 Alarm/Scheduler
 - 7.1.3 Key tone
 - 7.1.3.1 Tone Type
 - 7.1.3.2 Volume
 - 7.1.4 Function alert
 - 7.1.5 Hour alert
 - 7.1.6 Power On/Off
 - 7.1.7 Voice volume
- 7.2 Display
 - 7.2.1 Image box
 - 7.2.1.1 Turning on
 - 7.2.1.2 Turning off
 - 7.2.1.3 Wallpaper
 - 7.2.2 Banner
 - 7.2.3 Backlight
 - 7.2.4 External Clock
 - 7.2.5 Service LED
 - 7.2.6 Language/ 
- 7.3 Auto retry
- 7.4 Answer mode
- 7.5 Security
 - 7.5.1 Phone lock
 - 7.5.2 Change code
 - 7.5.3 Emergency #
 - 7.5.4 Restriction
 - 7.5.4.1 Outgoing calls
 - 7.5.4.2 Phone Book
 - 7.5.5 Clear memory
 - 7.5.5.1 Phone book
 - 7.5.5.2 Messages
 - 7.5.6 Reset phone
 - 7.5.6.1 Function Only
 - 7.5.6.2 All

7. Settings (continued)

- 7.6 Data/Fax Mode
- 7.7 Memory status
 - 7.7.1 Melodies
 - 7.7.2 Animations

8. VAS (see page 110)

- 8.1 Internet Portal
- 8.2 Games & App.
- 8.3 Ringtone
 - 8.3.1 Download New Ringtone
 - 8.3.2 Saved Ringtones
- 8.4 Animation
 - 8.4.1 Download New Animation
 - 8.4.2 Saved Animation
- 8.5 Voice Portal
- 8.6 SMS INFO
 - 8.6.1 News
 - 8.6.2 Sport
 - 8.6.3 Entertainment
 - 8.6.4 Fun
 - 8.6.5 Finance
 - 8.6.6 Astrology
- 8.7 GPS
 - 8.7.1 Voice Navigation
 - 8.7.2 Speed Traps Detector
 - 8.7.3 Where Is My Kid
 - 8.7.4 Emergency Button
- 8.8 What's new?

Using the menus

9. Camera (see page 120)

- 9.1 Take photo
- 9.2 Record video
- 9.3 Photo album
- 9.4 Video album
- 9.5 MMS
 - 9.5.1 New Photo
 - 9.5.2 Album
- 9.6 Settings
 - 9.6.1 Resolution
 - 9.6.2 Fun frames
 - 9.6.3 Color tones
 - 9.6.4 Shutter sound
 - 9.6.5 Quality
- 9.7 Memory status

In-Call menu (see page 34)

- 1: Mute/Quit
- 2: Calls
 - 2.1: Missed
 - 2.2: Incoming
 - 2.3: Outgoing
 - 2.4: Air Time
- 3: Phonebook
 - 3.1: Find
 - 3.2: Add
 - 3.3: Group Set
 - 3.4: My Phone #
- 4: Silent/Quit
- 5: Send My #
- 6: DTMF Length

Calls

You can use the **Calls** menu to:

- view and dial the last missed, outgoing, or incoming numbers.
- view the duration of calls.
- set the phone to receive the second call or to forward incoming calls to the preset number.

Missed (Menu 1-1)



If Caller Line Identification is available, your phone keeps a list of the 30 most recent incoming calls that you failed to answer. Contact your service provider for the availability.

When you press the **Menu** soft key on the call log list, the following options are available:

Erase: erases the selected number.

Erase all: erases all of numbers.

1. Press the Up and Down keys to find a number or name, if saved in Phone book.
2. Press the **Select** soft key to select the highlighted number. The dialed number, or name if stored in Phone book, displays.

3. To	Press the
place a call	 key.
use the menu options	Menu soft key. For details about the options, see below.
view other calls	Navigation keys.
return to Standby mode.	 key.

When you access the menu options, the following options are available:

Talk: dials the selected number.

Save: allows you to save the number in Phone book.

Prepend: allows you to add an area code or feature code to the number before calling the number.

Erase: allows you to erase the selected number.

Incoming *(Menu 1-2)*

This menu lets you view up to 30 of the most recent calls you have received if you are subscribed to the Caller Line Identification service. Contact your service provider for more information about this service. When you access this menu, the list of the incoming calls displays.

For further details about scrolling through the list and accessing the call log, see “Missed” on page 51.

Outgoing *(Menu 1-3)*

The phone stores up to 30 of the most recent calls you have dialed. When you access this menu, a list of the outgoing calls displays.

For further details about scrolling through the list and accessing the call log, see “Missed” on page 51.

Air Time *(Menu 1-4)*

Your phone records the amount of air time, or talk time, used. Using this option, you can view the number of the calls to or from your phone and the air time for all calls. You can easily erase the air time record at any time.

Note: This feature is not intended to be used for billing purposes.

The following options are available:

Last Call: shows the air time of the last call.

Total: shows the number of all calls you have made to or from your phone and the total duration of the calls since the air time counter was last set to zero by using the **Erase Total** option.

Life Time: shows the number and total duration of all calls you have made to or from your phone since the phone was shipped from the factory.

Erase Total: erases the “Total” air time measurement and resets the air time counter.

Phone book

You can store phone numbers and their corresponding names in the memories of your phone. The phone memories, although physically separate, are used as if they were a single entity, called Phone book.

Find *(Menu 2-1)*

This menu allows you to find an entry using a person's name, entry number, group name, or memory location.

Note: You can quickly access this menu by pressing the Right key in standby mode.

To change the finding method, press Left or Right key until the option you want to use displays; **By Name**, **By Entry**, or **By Group**.



Finding an entry by name

When you select this method, the whole list of all of Phone book entries appears in alphabetical order.

1. If necessary, press the Left or Right key to scroll to **By Name**.
2. If necessary, press the Down key to highlight the name input box.
3. Enter the first few letters of the name you want to find.

Your phone highlights the first matching name.

If you want to find a Hebrew name, press the **Menu** soft key and select **Hebrew** and press the **Select** soft key.

4. If necessary, press the Up or Down key to scroll through the entries.
 5. When an entry highlights:
 - Press the  key to place a call to the entry's speed-dial number.
 - Press the **Menu** soft key to access the following options:
 - **Edit**: edits the entry's phone number, name, location number, and other information.
 - **Erase**: erases the entry.
 - **Add New**: adds a number to Phone book. You can create a new entry or add it to an existing entry. For more information on how to add a number, see page 57.
 - Press the **OK** soft key to select the entry. Information about the entry displays. Move to each item by pressing the Up or Down key.
- Press the **Menu** soft key to use one of the following options:
- **Talk**: dials the number labeled as speed-dial number.
 - **Edit**: allows you to change the selected item.
 - **Erase**: erases the entry. If you select one of numbers for the entry, only the number is erased.
 - Press the **C** key to return to the previous screen.
 - Press the  key to exit the menu.

Finding an entry by entry number

When you select this method, the whole list of all of the Phone book entries appears in numeric order.

1. Press the Left or Right key to scroll to **By Entry**.
2. Press the Down key to highlight the number input box.
3. Enter the location number of the entry you want to find.
4. Follow the procedure from step 4 on page 55.

Finding an entry by group

When you select this method, a list of the Phone book entries in a group appears.

1. Press the Left or Right key to scroll to **By Group**.
2. Press the Down key to move the group selection field.
3. Press the Left or Right key to select the group you want.

Each time you select a group, a list of the associated entries displays.

4. Follow the procedure from step 4 on page 55.

Add *(Menu 2-2)*

This menu allows you to add a new entry to your Phone book by saving a phone number, an e-mail address, or a memo.

Adding a new entry using a number

1. After accessing the **Add** menu (**Menu 2-2**), select **Number** from the pop-up list and press the **Select** soft key.
2. Enter a number you want to save and press the **Save** soft key.
3. When **New Entry** highlights, press the **Select** soft key.
4. Enter a name and press the **OK** soft key.

For more information about how to enter characters, see page 37.

5. Choose a type icon, **Home**, **Office**, **Mobile**, **Pager**, or **Fax**, using the Navigation keys and press the **Select** soft key.
6. Press the Up or Down key and change the setting or enter more information, if necessary.
 - **Name:** Press the **Edit** soft key to change the name.
 - **Location number:** The first available location number displays. If necessary, change the location number using the Left or Right key.
 - **Home/Office/Mobile/Pager/Fax:** You can add numbers for each category or change the current number.

- **E-Mail1/E-Mail2:** Press the **Edit** soft key to enter an e-mail address. For more information about how to enter characters, see page 37.
 - **URL:** Press the **Edit** soft key to enter an URL address. For more information about how to enter characters, see page 37.
 - **Memo:** Press the **Edit** soft key to store additional information about the person.
 - **Speed Dial:** allows you to select one of the stored numbers for speed dialling.
 - **Group:** Select one of the default relation groups, where the entry is included. Grouping the entries enables you to search for a number in the group. See page 62.
 - **Ringer:** Press the **Menu** soft key to select a unique ringer melody for the entry. By selecting a different tone for each entry, incoming voice calls having a caller ID can be distinguished from those that do not.
 - **Caller Image:** Press the **Menu** soft key to select a character image to show on the external display when a call comes in from the number.
7. Repeat step 6 until you complete the contact information of the entry.
 8. Press the **Save** soft key to save the entry.

After storing, the phone displays the memory status of Phone book for a few seconds and goes to the Phone book list.

Saving a phone number from Standby mode

1. In Standby mode, enter a number you want to save.

Or, press the  key to end the call. The call time and the phone number display.
2. Press the **Save** soft key.
3. When **New Entry** highlights, press the **Select** soft key.

If you want to add a number into an existing entry, select **Pbook Entry** and press the **Select** soft key. To complete storing the number, follow the procedure from step 4 on page 60.
4. Enter a name and press the **OK** soft key.

For more information about how to enter characters, see page 37.
5. Follow the procedure from step 5 on page 57.

Adding a number into an existing entry

You can store up to 5 numbers for a name saved in the phone's memory by assigning them to the different types.

1. After accessing the **Add** menu (**Menu 2-2**), select **Number** from the pop-up list and press the **Select** soft key.
2. Enter a number you want saved and press the **Save** soft key.
3. Select **Pbook Entry** and press the **Select** soft key.

4. Find the name you want using the Up and Down keys and press the **OK** soft key.
5. Select a type icon by pressing the Navigation keys and press the **Select** soft key.
6. Follow the procedure from step 6 on page 57.

When the confirmation message to overwrite the entry appears, select **Yes** and press the **Select** soft key.

Adding a new entry using an e-mail address

You can store an e-mail address as a Phone book entry.

1. After accessing the **Add** menu (**Menu 2-2**), select **E-mail** from the pop-up list and press the **Select** soft key.
2. Enter the e-mail address and press the **OK** soft key.

For more information about how to enter characters, see page 37.

3. When **New Entry** highlights, press the **Select** soft key.

Note: To add the address to an existing entry, select **Pbook Entry**. Find the name from the Phone book list and press the **OK** soft key.

4. Enter a name and press the **OK** soft key.
5. Follow the procedure from step 6 on page 57.

Adding a new entry using a memo

You can make a memo about a person as a Phone book entry.

1. After accessing the **Add** menu (**Menu 2-2**), select **Memo** from the pop-up list and press the **Select** soft key.
2. Enter a memo and press the **OK** soft key.

For more information about how to enter characters, see page 37.
3. When **New Entry** highlights, press the **Select** soft key.

Note: To add the memo to an existing entry, select **Pbook Entry**. Find the name from the Phone book list and press the **OK** soft key.

4. Enter a name and press the **OK** soft key.
5. Follow the procedure from step 6 on the page 57

Group Set *(Menu 2-3)*

This menu allows you to change a relation group's name.

Note: You can't change the name of זכרון קבוע.

1. On the Group Set list, press the Up or Down key to select the group you want to rename and press the **Select** soft key.
2. Press the **C** key to erase the old group name.
3. Enter a name and press the **OK** soft key to save the new name.

For more information on how to enter characters, see page 37.

My Phone # *(Menu 2-4)*

This menu shows your phone number.

This number is sent when you choose the **Send My #** option during a call.

Message

Your phone can receive voice mail messages, text messages, and web messages from your web server. Your phone can also send text messages if your system supplier provides this service.

Incoming messages are received even when your phone is in Lock mode. The screen displays information about the message. To access the message, you need to unlock the phone.

Note: You can quickly access the **Message** menu by pressing the Left key in standby mode.

Text MSG *(Menu 3-1)*

You can create an SMS(Short Message Service) message and send it to other mobile phones.

New Message *(Menu 3-1-1)*

You can create short text messages and send them to multiple mobile phones.

Note: Message transmission is available only when your phone is operating in a digital network and if service is supported by your service provider.

Note: You can quickly access the **New Message** menu by pressing and holding the Left key in standby mode.

1. Enter the message contents and press the **OK** soft key.

For more information on how to enter characters, see page 37.

You can use up to 20 canned messages by pressing the **Mode** soft key and selecting **Templates**. For details, see page 76.

2. Select one of the following options, and press the **OK** soft key.
 - **Save & Send**: allows you to save a copy of the message and then send the message to the required destination. You can read the message in your Outbox.
 - **Save**: allows you to save the message so that it can be sent later. You can read the message in your Saved Msg box.
3. Enter a phone number.

If you press the **Find** soft key, you can search your Phone book for a number.

4. To send the message to multiple destinations, press the Down key and enter another number.

Repeat this step to add more destinations. You can send the message to up to 10 destinations at one time.

5. When you have finished entering the numbers, press the **OK** soft key to send or save the message.

Your phone informs you of whether or not the message was successfully sent, and returns to the Text MSG menu screen.



Inbox *(Menu 3-1-2)*

Your phone can store SMS messages and their corresponding Caller ID in your phone's memories. When your memory is full, the screen displays a

text notification and rejects additional incoming messages until you erase the obsolete ones.

When the phone receives a text message, the New Text Message icon (✉) and a text notification with the call back number appear. Press the **Select** soft key to view the message immediately.

When you access the **Inbox** menu, a list of the received message displays. An icon displayed in the list means the message's status:

- : displays when you have read the message.
- : indicates that a duplicated message.

While viewing the message list, press the Up or Down key to scroll to a message and:

- Press the **View** soft key to view the message you want. The phone displays the contents. If necessary, press the Up or Down key to scan through the message.

While viewing a message, press the **Menu** soft key to use the following options:

Reply: allows you to send a reply message to the sender.

Forward: allows you to send the message to other people.

Call/Save: shows the sender's number of the message. Press the  key to make a call to the sender's phone number. Press the **Save** soft key to save it.

Erase: erases the message from your Inbox.

Protect: the **Locked** option allows you to keep the message from being deleted. They will not be erased until you unlock by using the **Unlocked** option.

- Press the **Reply** soft key to send a reply message to the sender.
- Press the **Menu** soft key to access the following options:

Erase: allows you to erase the selected message.

Erase Multi: allows you to erase the messages you selected by pressing the **Check** soft key.

Erase all: allows you to erase all of the messages.

Outbox *(Menu 3-1-3)*

Your phone can store your outgoing SMS messages in your phone's memories.

When you access the **Outbox** menu, you can see the message list.

While viewing the message list, press the Up or Down key to scroll to a message and:

- Press the **View** soft key to view the message you want. The phone displays the contents. If necessary, press the Up or Down key to scan through the message.

While viewing a message, press the **Menu** soft key to use the following options:

Resend: allows you to send the message to other people.

Call/Save: shows the destination number of the message. Press the  key to make a call to the recipient's phone number. Press the **Save** soft key to save it.

Erase: erases the message from your Outbox.

- Press the **Resend** soft key to send the message to other people.
- Press the **Menu** soft key to use the following options:

Erase: allows you to erases the selected message.

Erase Multi: allows you to erases the messages you selected by pressing the **Check** soft key.

Erase all: allows you to erases all of the messages.

Saved Msg *(Menu 3-1-4)*

Your phone can store draft messages that are yet to be sent in the Draft box. If you save the message contents before sending, you can access them using this menu.

To review a stored message, press Up or Down key to scroll to it and press **View** soft key.

While viewing a message, press the **Resend** soft key to send the message to other people.

While viewing a message, press the **Menu** soft key to use the following options:

Resend: allows you to send the message to other people.

Call/Save: shows the sender's number of the message. Press the  key to make a call to the sender's phone number. Press the **Save** soft key to save it.

Erase: erases the message from your Saved Msg.

- Press the **Menu** soft key to access the following options:

Erase: allows you to erase the selected message.

Erase Multi: allows you to erase the messages you selected by pressing the **Check** soft key.

Erase all: allows you to erase all of the messages.

MMS *(Menu 3-2)*

MMS (Multimedia Message Service) allows you to send or receive a message containing an image or a sound. It provides delivery of multimedia messages from phone to phone or from phone to e-mail.

New Message *(Menu 3-2-1)*

In this menu, you can create and send a new message.

1. When the **Send To** field highlights, press the **Menu** soft key.

Note: You can select a address type, Send To, Cc, or Bcc, by pressing the Left or Right key.
2. Select **Phonebook** to retrieve a phone number or an e-mail address from your Phone book, or **Input** to an enter one.
3. Choose a number or an address or enter one, and then press the **OK** soft key.
4. Press the Down key to move to the **Subject** field and press the **Edit** soft key.

5. Enter a subject and press the **OK** soft key.
6. Press the Down key to move the **Picture** field and press the **Menu** soft key.

The following options are available:

- **Take Photo:** allows you to take a new photo using the camera.
 - **Album:** allows you to select a photo from the Photo album.
 - **Saved Img:** allows you to select one of images you have received by MMS message.
 - **Erase:** remove the image from the slide.
7. Select an option and take a photo or add an image.

For details about the camera, see page 120.
 8. Press the Down key to move the **Message** field and press the **Edit** soft key.
 9. Enter a message text and press the **OK** soft key.
 10. Press the Down key to move to the **Sound** field and press the **Menu** soft key.

The following options are available:

- **Voice Rec:** allows you to record a new voice memo.
- **Voice Memo:** allows you to select one of voice memos you have recorded.
- **Melody:** allows you to select one of the default melodies.
- **Saved Snd:** allows you to select one of sounds you have received by MMS message.
- **Erase:** remove the sound from the slide.

11. Select an option and then record a memo or select a sound.

For details about the voice memo, see page 91.

12. If you want to add or remove a slide, move to the **Slide** field and press the **Menu** soft key.

The following options are available:

- **Add:** adds a new slide.
- **Erase:** erases any added slides.
- **Duration:** allows you to set the length of time the currently selected slide displays.

13. When you have finished the MMS message, press the **OK** soft key.

The following options are available:

- **Preview:** shows the message you created.
- **MMS Edit:** allows you to change the message.
- **Options:** allows you to set message options; for details on each option, see page 75.
- **Save in Draft:** saves the message in the Draft box.

14. When you are satisfied, press **1** or select **preview** and press the **OK** soft key.

The phone displays your message.

15. Press the **Send** soft key to send it.

Inbox *(Menu 3-2-2)*

When a new MMS message has arrived, an MMS alert appears. You can select **Yes** to download the message from the MMS server or **No** to check the message at a later time. If you select **Yes**, the message will be saved in the Inbox.

When you access the Inbox, the list of the retrieved messages displays. On the message list, you can access the following options by pressing the **Menu** soft key:

Erase: allows you to erase the currently selected message.

Erase All: allows you to erase all of the messages in the Inbox.

Select a message from the list and press the **OK** soft key to read it. The phone presents the message contents. If a sound file is attached, it plays. On the message presentation screen, you can access the following options by pressing the **Menu** soft key:

Reply: allows you to send a reply to the sender.

Reply All: allows you to send a reply to the sender and all of the recipients.

Forward: allows you to forward the message to other people.

Erase: allows you to erase the message.

Info: shows the information of the message.

Save Img: saves an image from the message to the phone's memory.

Save Snd: allows you to save a sound from the message to the phone's memory.

Protect: protects the message so that it will not be erased.

Outbox *(Menu 3-2-3)*

From this menu, you can access the list of the messages you have sent. On the message list, you can access the following options by pressing the **Menu** soft key:

Erase: allows you to erase the currently selected message.

Erase All: allows you to erase all of the messages in the Inbox.

Select a message from the list and press the **OK** soft key. The phone presents the message contents. If a sound file is attached, it plays. On the message presentation screen, you can access the following options by pressing the **Menu** soft key:

Resend: allows you to resend the message.

Erase: allows you to erase the message.

Info: shows the information of the message.

Protect: locks/unlocks the message so that it is not erased.

Draftbox *(Menu 3-2-4)*

From this menu, you can access the messages you have saved before sending or you have tried.

Select a message from the list and press the **OK** soft key. the message opens in Edit mode so that you can change and send it.

MMS Alert *(Menu 3-2-5)*

When a new MMS message has arrived, an MMS alert appears. You can select **Yes** to download the message from the MMS server or **No** to check the message at a later time. If you select **No**, the alert saved in the MMS Alert box.

Select an alert from the list and press the **OK** soft key.

To retrieves the message from the MMS server, press the **Download** soft key.

To erases the MMS alert, press the **Erase** soft key.

Voice Mail *(Menu 3-3)*

When you receive a voice message the corresponding text notification displays. Press  and the phone dials the voice mail center.

Note: Press and hold the right soft key to dials the voice mail center in Standby mode.

If multiple new voice messages are received but not checked, information of the last one will be displayed. The information display includes the time/date stamp and the number of new voice messages.

Msg Setup *(Menu 3-4)*

Using this menu, you can set up various options for receiving or sending messages.

Scroll Timer *(Menu 3-4-1)*

If an incoming message is too long for the display, the phone scrolls the screen automatically. You can set the time interval in which the phone scrolls to the next screen, **1** through **5** seconds.

When this option is set to **Off**, you need to manually scroll to the next screen using the Up or Down key.

Msg. Reminder *(Menu 3-4-2)*

When a message is received, your phone alerts you by sounding the specified ringer. You can set how often this will happen.

Off: The phone alert only once when you receive an incoming message.

Once: The phone alerts you when you receive an incoming message and then alert you again after 2 minutes.

Every 2 min: The phone alerts you every 2 minutes when you receive an incoming message.

Alert on call *(Menu 3-4-3)*

This menu allows you to choose whether or not the phone informs you when you receive a new message during a call.

Off: the phone doesn't actively alert you to incoming messages. It only displays the corresponding notification.

On: the phone alerts you with a beep and displays the corresponding notification.

SMS Message *(Menu 3-4-4)*

You can set up the following options as default settings when creating a new message.

Delivery Ack: allows you to activate or deactivate the delivery acknowledgement feature. When this feature is activated, the network informs you when your message is delivered to the recipient. Select **On** to turn the feature on, or **Off** to turn it off.

MMS Message *(Menu 3-4-5)*

You can change the default settings for sending and receiving MMS messages.

Priority: allows you to select a message priority.

Expiry: allows you to set the length of time your messages are stored in the MMS server while attempts to deliver them.

Delivery Time: allows you to select time delay before the MMS server sends messages.

Sender Visibility: allows you to set whether your phone number will be seen on recipients' phones.

Message

Delivery Report: allows you to request that the network inform you when your message has been delivered.

Read Reply: allows you to request that the network inform you when the recipient reads your message.

Retrieval Mode: allows you to set how you want to retrieve incoming MMS messages. With this option is set to **auto**, the phone retrieves MMS messages from the MMS server immediately at the time of their arrival. When you select **prompt**, the phone shows a prompt so that you can choose to retrieve the message.

Msg. Templates *(Menu 3-4-6)*

Your phone has 11 preset messages to enable you to use them when writing a new message. You can change them, if necessary.

You can also add up to 9 messages.

1. Press the Navigation keys to highlight the message you want to change.

To add a new message, select an empty location.

2. Press the **Select** soft key.
3. Clear the existing message using the **C** key, if necessary, enter a new message.

For further information on how to enter text, see page 37

4. Press the **OK** soft key to save the message.

Scheduler

The Scheduler feature enables you to:

- keep track of important dates and events.
- set the phone to ring at a specified time.
- set the current time and date.
- use the phone as a calculator.
- create a list of things to do or memos.
- check the current time in another part of the world.
- set and count down to a particular day or event.
- make a memo.

Note: When you are out of your service area, you cannot use some of the features in the **Scheduler** menu.

Calendar *(Menu 4-1)*

This menu allows you to view the current month, as well as the past or future month in the calendar format. You can be alerted by the Calendar function before an event commences. When you access this menu, today's date is automatically selected the date in lunar calendar displays on the bottom.

Selecting a day on the calendar

- You can move to the next or the previous day by pressing the Left or Right key.
- You can move up or down the Calendar one week by pressing the Up or Down key.
- To display the next or previous month, use the Volume keys on the left side of the phone.

On the Calendar screen, press the **Menu** soft key to use the following options:

View: allows you to view the scheduled events of the day.

Add new: allows you to add a new event on the selected day.

Scheduling an event

You can schedule up to 9 events for one day and 20 events total.

1. Select a day from the calendar, referring to "Selecting a day on the calendar" on page 77, and press the **OK** soft key.
2. Enter your event contents and press the **OK** soft key.

For more information about how to enter characters, see page 37.

3. Enter the start time and date using the numeric keys and press the Down key.

Notes:

- You need to enter the time in 24-hour format.
- You can move through the input fields using the Left or Right key.

4. Enter the end time and date using the numeric keys and press the Down key.
5. Specify when an alarm will inform you of your event by pressing the Left or Right key. If you select **No alarm**, the phone does not ring the alarm.
6. Press the **Save** soft key to save your event.

Viewing your schedule

Days with scheduled events are seen in a rectangle on the calendar when you access the **Calendar** menu (**Menu 4-1**). Select one of them and press the **OK** soft key. The first of the events for date appears.

Highlight to the event you want to view by pressing the Left or Right key. If necessary, press the Down key to display the end time of the event.

While viewing an event, press the **Menu** soft key to use the following options:

Add new: adds a new event.

Edit: edits the selected event.

Erase: erases the selected event.

Erase All: erases all of the events.

Alarm Set *(Menu 4-2)*

This menu allows you to set the alarm to ring at a specific time.

To set the alarm:

1. Select the alarm frequency option by pressing the Navigation keys.
 - **Once:** The alarm rings only once and is then deactivated.
 - **Daily:** The alarm rings everyday at the same time.
2. Press the **Save** soft key.
3. Enter the time for the alarm to ring by using the numeric keys.

Notes:

- You need to enter the time in 24-hour format.
- You can move through the input fields using the Left or Right key.

4. Press the **Save** soft key.

To stop the alarm when it rings, simply open and close the phone or press any key.

To deactivate the alarm, access the **Alarm Set** menu, and select **Off** and press the **Save** soft key.

Set time *(Menu 4-3)*

This menu allows you to set the current date and time. The following options are available:

Main clock

You can set the current time. When you select this menu, the current settings, if set, displays. In a service area, you don't need to change the time and date setting.

1. Enter the current time and date using the numeric keys.

The month, day, hour, and minute must each be entered using 2 digits and the year requires all four digits.

Notes:

- You need to enter the time in 24-hour format.
- You can move through the input fields using the Up or Down key.

2. When you finish, press the **Save** soft key.

Dual clock

You can choose two time zones to be displayed when you select **Dual clock** for the Wallpaper image in the **Wallpaper** menu (**Menu 7-2-1-3**). You can also set the daylight saving time for the selected time zones.

To select time zones for the dual clock:

1. When **Location** highlights, press the Down key.
2. Select the time zone for the left clock by pressing the Left or Right key and press the Down key.

3. Select the time zone for the right clock by pressing the Left or Right key.

4. Press the **Save** key.

To apply the daylight savings:

1. When **Location** highlights, press the Left or Right key to select **Summer Time**. Press the Down key.

2. Select **On** to use the daylight saving time for the left clock. Otherwise, select **Off**.

3. Press the Down key and repeat step 2 for the right clock.

4. Press the **Save** key.

Calculator *(Menu 4-4)*

Using this feature, you can use the phone as a calculator. The calculator provides the basic arithmetic functions; addition, subtraction, multiplication, and division.

To perform a calculation:

1. Enter the first number using the numeric keys.

Note: Use the \times key to enter a decimal point and the $\#$ key to change the sign of a number to a negative (-).

2. Select the operation for your calculation by pressing the Navigation keys according to the illustration on the display; + (add), - (subtract), \times (multiply), \div (divide).

3. Enter the second number.

4. To get the result, press the **OK** soft key.

5. Repeat steps 1 to 4 as many times as required.

Today *(Menu 4-5)*

This menu allows you to schedule new events for the current day, indicating each event's start and end time. Events scheduled for future dates automatically appear on your Today display for that particular day.

For further details about scheduling and viewing events, refer to "Calendar" on page 77.

To Do List *(Menu 4-6)*

This feature allows you to enter up a list of tasks you need to do and assign both a priority and a deadline to them. You can store up to 20 tasks.

Creating a to-do item

1. Enter the task contents and press the **OK** soft key.

For more information about how to enter characters, see page 37.

2. Select High or Low priority using the Left or Right key and press the Down key.
3. Enter the time and the date when your task needs to be done using the numeric keys.

Notes:

- You need to enter the time in 24-hour format.
- You can move through the input fields using the Left or Right key.

4. Press the **Save** soft key to save the task.

Viewing a task

When you access the **To Do List** menu (**Menu 4-6**), the list of tasks displays along with deadline and the associated priority highlighted: ★ for high priority or ★₂ for low priority.

Scroll to the task you want to view by pressing the Left or Right key.

While viewing a task, press the **Menu** soft key to use the following options:

Add new: adds a new task.

Edit: edits the selected task.

Erase: erases the selected task.

Erase All: erases all of the tasks.

World time *(Menu 4-7)*

You can use this menu to find out what time it is in another part of the world and apply the DST (Daylight Saving time).

Press the Navigation keys to scroll to the time zone you want to check.

To apply the daylight saving time:

1. After selecting the time zone you want to apply the DST, press the **DST** soft key.
2. When a confirmation message appears, select **Yes** and press the **Select** soft key. The DST icon appears on the left side of the time.

Countdown *(Menu 4-8)*

This menu helps you know how much time it takes for you to do something or how many months, days, hours, and/or minutes until a specific event occurs. You can create up to 20 Countdown timers using this feature.

Creating a countdown timer

1. Enter a name for your Countdown timer and press the **OK** soft key.

For more information about how to enter characters, see page 37.

2. Enter the time and date from which you want to count down.

Notes:

- You need to enter the time in 24-hour format.
- You can move through the input fields using the Left or Right key.
- You can enter between 1981 and 2099 for the year.

3. Press the **Save** soft key to save the timer.

Viewing a countdown timer

The list of Countdown timers displays when you access the **Countdown** menu (**Menu 4-8**).

Scroll to the timer you want to view by pressing the Left or Right key.

While viewing a timer, press the **Menu** soft key to use the following options:

Add new: creates a new timer.

Edit: edits the selected timer.

Erase: erases the selected timer.

Erase All: erases all of timers.

Memo pad *(Menu 4-9)*

This feature allows you to make memos of important things you need to remember.

Writing a new memo

1. Enter what you need to remember.

For further details on how to enter characters, see page 37.

2. Press the **OK** soft key to save the memo.

Viewing a memo

The list of your memos displays when you access the **Memo pad** menu (**Menu 4-9**).

To view details, press the Navigation keys to scroll to the memo you want to view from the list and press the **Select** soft key.

On the Memo pad list, press the **Menu** soft key to use the following options:

Add new: adds a new memo.

Edit: edits the selected memo.

Erase: erases the selected memo.

Erase All: erases all of memos.

Games

Using the **Games**, you can enjoy games using your phone.

You can enjoy games using your phone.

To start a game:

1. Press the Navigation keys to scroll to one of the games and press the **Select** soft key.
2. Press any key except for the  key.

The phone displays the following options:

- **NEW GAME:** allows you to start a new game.
- **HIGH SCORE:** shows you the high score table.
- **HELP:** gives you the information about how to play the game.
- **KEY INFO:** gives you the key helper screen to play the game.
- **CONTINUE:** allows you to continue the last game you played. This option is activated only when you have played a game.

3. While playing a game:

To	Press the
pause/resume the game	C key.
exit the game	 key.

Chicken run *(Menu 5-1)*

The goal of this game is to move eggs or chicks to the destination carefully.

When you select **NEW GAME** menu, the first screen displays two menus.

Select **START** menu to start a new game.

Select **OPTION** menu to change following options.

DIFFICULTY: allows you to change the game's level of difficulty.

SOUND: allows you to turn the game sound on or off.

VIBRATION: allows you to turn the vibration on or off.

 : allows you to exit the current screen.

Once the game starts, you need to control blue and red control items to move eggs or chicks carefully. To control the blue items, press **1** or Left key, and press **3** or Right key for the red ones. When you complete the given aims, the level goes up and the speed goes up.

Mobile cop *(Menu 5-2)*

The goal of this game is to shoot the enemies.

When you select **NEW GAME** menu, the first screen displays three menus.

Select **START** menu to start a new game.

Select **OPTION** menu to change following options.

Games

SOUND: allows you to turn the game sound on or off.

VIBRATION: allows you to turn the vibration on or off.

← : allows you to exit the current screen.

Select **HELP** menu to see the simple guide.

Once the game starts, enemies in red appear at target position. Check the position and press appropriate number key to shoot the enemy.

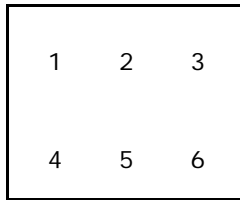

Sometimes hostages may appear. If you shoot the hostage, you will lose the bonus points.

After running out of the bullets, press **7**, **8** or **9** to reload them.

Whenever you kill all the enemies for one stage, you can go to the next stage.

Voice Tools

In this menu, you can use the phone's voice features, allowing you to:

- record a voice memo.
- set the phone to answer a call and record the caller's message.

Voice Memo *(Menu 6-1)*

Record *(Menu 6-1-1)*

You can record up to voice memos of 4 minutes total. This feature shares the memory with the Voice Answer feature and the amount of time for memos are dependent on the available memory less any callers' messages; for example, if your phone has the callers' messages of 4 minutes total, you cannot record any voice memo.

1. Record a memo by speaking to the microphone.

When you are recording, a timer displays to show you the elapsed time.

You can pause recording by pressing **Pause** soft key and then **Resume** soft key.

2. Press the **End** soft key to end recording. The screen provides you with the following choices. Scroll to an option and press the **Select** soft key.

- **Review:** allows you to review the voice memo. The screen displays the length of the memo.

- **Rerecord:** allows you to discard the current memo and record another one.
 - **Save:** allows you to save the voice memo.
 - **Quit:** allows you to quit recording the memo and exit the **Record** menu.
3. When you are satisfied, select the **Save** option and press the **Select** soft key.
 4. Enter a title for the memo and press the **OK** soft key.

Review *(Menu 6-1-2)*

When a list of your voice memos displays, scroll to the memo you want to review and press the **Select** soft key. The phone plays back the memo.

On the memo list, press the **Menu** soft key to use the following options:

Play: plays back the memo.

Info: shows detailed information about the memo, such as title, length, memory size and date and time when the memo was recorded.

Erase: erases the selected memo.

Erase All: erases all of the memos.

Voice Answer *(Menu 6-2)*

If you are not able to answer an incoming call, you can set your phone to answer a call with the default greeting message and record the caller's message. As this feature shares the memory with voice memos, the total length of messages is dependent on the available memory less any voice memos.

Note: You can quickly access this menu by pressing the **VA** soft key in standby mode.

On/Off *(Menu 6-2-1)*

This option allows you to enable or disable the answering machine mode.

Voice Messages *(Menu 6-2-2)*

You can listen to the callers' messages recorded in your phone. When you access this option, a list of the recorded messages appears.

Note: If the phone has the callers' messages waiting to be checked, it displays the total number of the messages when the last message was recorded.

On the message list, press the **Menu** soft key to the following options:

Play: plays the selected message.

Info: shows detailed information about the message, such as caller's number if identified, elapsed time, memory size and date and time when the message was recorded.

Erase: erases the selected message.

Erase All: erases all of the messages.

Setting *(Menu 6-2-3)*

You can change the settings for the voice answer mode. The following options are available:

Greeting: Your phone provides you with the default greeting message to be played when a call comes in. You can also record your own greeting message.

To record a greeting message:

1. Select **Record** and press the **Select** soft key.
2. Wait until a beeping prompt sounds and record a greeting message by speaking into the microphone.

You can pause recording by pressing **Pause** soft key and then resume by pressing **Resume** soft key.

3. When recording is complete, press the **End** soft key. The phone automatically saves and activates the message.

If you want to play back the currently selected message, highlight **Play** and press the **Select** soft key.

To enable or disable your own greeting message:

1. Highlight **Select** and press the **Select** soft key.
2. Select **My Msg.** to use your message or **Default** to use the default message.
3. Press the **Select** soft key to save your selection.

Note: Once you have recorded your own message and then have changed the greeting to the default message, your message is deleted.

Screening: allows you to enable or disable the screening speaker which allows you to listen to the caller's message while the caller is leaving it.

Wait Time: allows you to set how long the phone waits before answering a call with the greeting message. Selecting **Immediate** means that the phone plays back the message as soon as a call comes in.

Settings

Many different features of your phone can be customized to suit your preferences.

Sounds *(Menu 7-1)*

You can use this menu to customize various sound settings, such as the:

- ringer.
- ringer volume.
- key tone.
- tones that sound while using the phone's functions.
- tone that alerts you every hour on the hour.
- tone that the phone sounds when you turn on or off the phone.
- voice volume.

Ringer *(Menu 7-1-1)*

This menu allows you to set the unique ringer melodies for calls, messages, and alarms. You can select default melodies or ones downloaded from the wireless web.

- **Voice calls:** allows you to select a ringer for the incoming calls.
- **Messages:** allows you to select a ringer for incoming messages.
- **Alarm/Scheduler:** allows you to select a ringer for alarm and scheduler.

To select a ringer melody:

1. Select the item you want and press the **Select** soft key.
2. Press the Down key.
3. Select the melody you want using the Up or Down key.
4. Press the **Save** soft key.

Ringer Volume *(Menu 7-1-2)*

In this menu, you can adjust the ringer volume for the following items:

Voice calls: allows you to adjust the ringer volume for incoming calls.

Messages: allows you to adjust ringer volume for incoming messages.

Alarm/Scheduler: allows you to adjust ringer volume for alarm and scheduler.

To adjust a ringer volume, select the item you want to adjust the volume level and press the Volume keys to adjust the volume level. The following options are available:

No tone: The phone does not sound a ring.

1 Beep: The phone sounds a beep.

Vibrate: The phone vibrates for incoming calls.

Level 1 ~ 5: You can adjust the volume level. The graphic shows the volume level; the more bars, the louder the volume.

Note: Available options may vary, depending on the item you select.

Key tone *(Menu 7-1-3)*

Using this menu, you can set up the keypad tone that the phone sounds when you press a key.

The following options are available:

Tone Type: allows you to select a tone that the phone sounds when you press a key. Choose one of **Man(Heb)**, **Lady(Eng)**, **Raindrop** and **Beep**.

Volume: allows you to adjust the volume of the keypad tone using the Navigation keys or the Volume keys on the left side of the phone.

Function alert *(Menu 7-1-4)*

Your phone gives audible alerts (beeps) at a specified time to inform you that certain things have happened. The alerts only occur in your earpiece so the other person on the phone does not hear them.

The following alerts are available:

Minute Beep: When this alert is selected, the phone sounds an alert 10 seconds before each elapsed minute to remind you of the length of the current call.

Service area: When this alert is selected, the phone sounds an alert when you exit your service area or when you return to the service area.

Connect: When this alert is selected, the phone sounds a connect tone when your call is connected to the system.

Disconnect: When this alert is selected, the phone sounds a disconnect tone when a call is disconnected.

Fade: When this alert is selected, the phone sounds an alert when a dropped call occurs during conversation in response to a signal fade.

Folder: When this alert is selected, the phone sounds an alert when you open or close the phone.

To turn on an alert:

1. Select an alert using the Navigation keys and press the **Select** soft key.
2. When a confirming message displays, select **On** and press the **Select** soft key.

Hour alert *(Menu 7-1-5)*

You can set your phone to sound an alert every hour on the hour.

1. Enter the period of time using the numeric keys and press the Down key.
2. Select the alert type, **Cuckoo** or **Voice**, using the Left or Right key.
3. Press the Down key and select **On** using the Left or Right key.

If you don't want to use the hour alert, select **Off**.

4. Press the **Save** soft key.

Power On/Off *(Menu 7-1-6)*

You can select the tone that the phone sounds when you turn on or off the phone.

To turn off the sound, select **Off**.

Voice volume *(Menu 7-1-7)*

This menu enables you to adjust the voice volume of the earpiece.

Press the Navigation keys to adjust the volume. You can also use the Volume keys on the left side of the phone. The graphic shows the volume level; the more bars you see, the louder the volume.

Note: During a call, you can adjust the volume using the Volume keys on the left side of the phone.

Display *(Menu 7-2)*

The Display feature enables you to:

- change a background image or an image to be displayed when the phone turns on or off.
- set a banner message.
- set the length of time for the backlight.
- set the external clock type.
- turn the service light on or off.
- change the display language.

Image box *(Menu 7-2-1)*

This menu allows you to change the background image to be displayed in Standby mode or when the phone is turned on or off. You can also erase downloaded or captured images.

The following options are available:

Turning on: You can select an image to display when you turn on the phone.

Turning off: You can select an image to display when you turn off the phone.

Wallpaper: You can select an image to display on the idle screen.

To select an image:

1. Select an item you want and press the **Select** soft key.
2. Select the image category you want and press the **Select** soft key.

You can select one of the default images, ones downloaded from the web, or photos you took.
3. Scroll through the images using the Navigation keys.
4. Press the **Select** soft key when you find the image you want.

Banner *(Menu 7-2-2)*

This menu allows you to set a banner message to be displayed at the bottom of the display in Standby mode.

To change the banner:

1. If necessary, press the **C** key to clear the old message.
2. Enter a new banner message using the alphanumeric keys.

For more information about how to enter characters, see page 37.
3. When you finish entering the message, press the **OK** soft key to save it.

Backlight (Menu 7-2-3)

This menu allows you to select the length of time the backlight remains on.

When the phone is open, the backlight remains on for the specified length of time after the last key is pressed or you open the phone. Remember that backlight use drains your battery faster.

External Clock (Menu 7-2-4)

You can change the type of clock to be displayed on the external display in Standby mode.

Select one of the four options; **Digital** and **Analog 1** through **Analog 3**.

Service LED (Menu 7-2-5)

The service light on the front of the phone blinks to indicate the service status. In this menu, you can activate or deactivate the feature of the service lights.

Language/שפה (Menu 7-2-6)

You can change the language of the menu display. Select either עברית or **English**.

Auto retry (Menu 7-3)

When this menu is set to **On**, your phone automatically redials the number when a connection fails.

Depending on your location, the number of times your phone automatically redials may be different.

Answer mode (Menu 7-4)

This menu allows you to select how to answer an incoming call.

The following options are available:

By send key: The phone answers only when you press the  key.

By folder open: The phone answers when you open the phone. If the phone is already open, press the  key.

By any key: The phone answers when you can press any key except for the  key, the soft keys, and the Volume keys.

Security *(Menu 7-5)*

Your phone provides you with various security options, including a user-programmable lock code and emergency numbers.

To access the **Security** menu, you must enter the 4-digit lock code. It is preset to "0000" at the factory.

Phone lock *(Menu 7-5-1)*

In Lock mode, you cannot dial numbers, except for making an emergency call, or accessing menu options. The phone can receive incoming calls and messages, even though the phone is in Lock mode.

The following options are available:

On: You are required to enter the lock code when you switch on the phone.

Off: You are not asked to enter the lock code when you switch on the phone.

To place an emergency call in Lock mode, enter a programmed number and then press the  key. The phone recognizes standard emergency numbers, such as 100, or three numbers programmed in the **Emergency #** menu (**Menu 7-5-3**); see page 105.

To unlock the phone, press one of the soft keys, one of the volume keys, one of the navigation keys, Camera key, VAS key, or  key and enter the 4-digit lock code. The phone is immediately unlocked.

Change code *(Menu 7-5-2)*

This feature allows you to change your current lock code to a new one. The lock code is preset to "0000" at the factory.

Enter a new, four-digit lock code and enter the code once again at the prompt.

Note: Your phone does not allow viewing of the lock code for security reasons, so be sure to write the lock code down or memorize it if you have changed.

Emergency # *(Menu 7-5-3)*

Your phone provides the option of storing three emergency numbers. All of these numbers can be manually dialed at any time, even if your phone is locked or all outgoing calls are restricted.

IMPORTANT NOTICE!

Emergency calling may not be available on all wireless networks at all times, due to the various transmission methods, network parameters and user settings used to complete a call from your wireless phone. A connection cannot always be guaranteed.

DO NOT depend on this phone as a primary method of dialing 100 or for any other essential or emergency communications.

Remember to always turn on your phone and check for the adequate signal strength before placing a call.

To store an emergency number:

1. Press the Up or Down key to select a location and press the **Select** soft key.
2. Press the **C** key to clear the existing number.
3. Enter a number and press the **Save** soft key to save the number.

Note: You can not modify the default numbers such as 100, 101, 102 and *166.

To make an emergency call in Lock mode, simply enter one of the programmed emergency numbers and press the  key.

Restriction *(Menu 7-5-4)*

This feature allows you to restrict the use of your phone.

The following options are available:

Outgoing calls: restricts outgoing calls from your phone, except emergency calls by standard emergency numbers, such as 100, 101, 102 and *166, or three programmed numbers in **Emergency # (Menu 7-5-3)**.

Phone Book: restricts access to your Phone book. You cannot also add a new entry.

When a confirmation message displays, select **Yes** to turn it on or **No** turn it off.

Clear memory *(Menu 7-5-5)*

This feature allows you to clear all of the numbers in your Phone book.

You can also erase all of the messages by selecting **Messages**.

When a confirmation message appears, select **Yes** and press the **Select** soft key.

Reset phone *(Menu 7-5-6)*

This menu allows you to restores the default settings of all of user-selectable options, or the phone's memory.

The following options are available:

Function Only: allows you to restores the default settings of all of user-selectable options.

All: allows you to restores information except for the SMS and phonebook.

When a confirmation message displays, select **Yes** and press the **Select** soft key to confirm. The phone reboots, turning itself off and then back on, and returns to Standby mode.

Select **No** to cancel your selection.

Data/Fax Mode *(Menu 7-6)*

Your phone is capable of sending and receiving digital data and fax call when connected to a computing device (laptop, desktop, handheld, palmtop, etc.) running Windows 95, Windows 98, Windows NT or later versions. The phone functions just like a typical modem on your PC, enabling you to use wireless data involving a wide variety of Windows software applications.

To use digital data or fax services with your phone, you will need to obtain a digital data/fax kit from your service provider. This kit contains the necessary cables, software, and user's guide required for you to connect and use your phone with your computing device.

Note: The phone must be on a digital network to receive or send faxes and data.

The following options are available:

Data/Fax off: Your phone doesn't receive Data and Fax.

Fax for next call: Your phone receives Fax when next call is incoming.

Fax until powered off: Your phone receives Fax until your phone is powered off.

Data for next call: Your phone receives Data when next call is incoming.

Data until powered off: Your phone receives Data until your phone is powered off.

Receiving a fax or data

To receive a fax or data, ensure that your phone is connected to your PC and is powered on. Select one

of the Data/Fax options. When you receive a fax call, set up the **Answer mode** in the fax program on your PC and click on **Receive** and select one of the following:

- Automatic Receive (recommended)
- Manual Receive

Sending a fax or data file

When connected to a computing device, your phone allows wireless fax and data transmissions. Your computing device software initiates the call to the destination phone number. The phone functions as a wireless modem to send the fax or data file to the number designated by your PC software.

Memory status *(Menu 7-7)*

This menu allows you to check the number of media contents you have downloaded from the wireless web.

This menu allows you to use a variety of services supplied by your service provider, such as the:

- WAP browser
- Voice portal service
- SMS information service

Note: You can quickly access this menu by pressing the **z** key in Standby mode.

Internet Portal *(Menu 8-1)*

Your phone is equipped with a WAP (Wireless Application Protocol) browser which allows you to access and navigate the wireless web.

Selecting the **Internet Portal** menu launches the WAP browser. Once you are connected to the network, the homepage of your service provider.

Navigating the browser

To	Press
Scroll through browser items	Up and Down keys.
Scroll through browser items by one page	Volume keys.
Choose an item	✓ soft key, or press the Menu soft key and select Done .

To	Press
Return to the previous page	Dismiss or Cancel soft key.
Access browser menus	Menu soft key and select Browser menu . For details about each option, see "Using the browser menus".
Exit the browser	 key.

Entering text in the browser

When you are in a text input field, you can use the following input mode; to change the input mode, press the **abc** soft key and select a mode:

Hebrew: allows you to enter Hebrew letters as you would in ABC mode.

Sym: allows you to enter symbols or punctuation marks.

Number: allows you to enter numbers.

English: allows you enter English characters by pressing the key one or more times until the letter you want appears.

Using the browser menus

When you access the browser menu list, the following options are available:

Back: goes back to the previous page.

Home: accesses the homepage.

Exit: exits the browser.

Bookmarks: allows you to make a bookmark for the current page, or use the bookmark list to quickly access a page.

Go To URL: allows you to enter a URL address of the web page you want to access.

Show URL: shows the URL address of the current page.

Reload: refreshes the current page using the updated information.

Settings: provides you with further options.

Homepage: allows you to change the startup homepage manually.

Downloads: allows you to download image or sound items on the current web page.

Restart Browser: restarts the browser without exiting it.

Delete Cookies: deletes all of the cookies and files. A cookie is a piece of user's information that is entered when you use a web site.

View Title Region: allows you to set whether or not the browser shows the title of a web page.

Scroll Mode: lets you set the scroll mode to either **Block** or **Smooth**, or set the speed for scrolling to the next screen, to either **Fast**, **Medium**, or **Slow**.

Send Referrer: allows you to set the browser to send HTTP referrer information to the web server each time the browser is launched.

Key Press Timeout: allows you to set how long the phone waits after you have pressed a key in the text entry mode before moving the cursor to the right. You can select **Fast**, **Medium**, or **Slow**. If you don't want to set the timeout, select **Off**.

Connection Timeout: allows you to set how long the phone keeps connection to the current web page when you don't use the web page. You can select **30seconds** or **60seconds**.

Security: displays all security-related information, such as Secure Prompt, Authentication, and Current Certificate.

About: shows the WAP browser version and copyright, encryption, and certificate information.

Games & App. *(Menu 8-2)*

In this menu, you can use Brew applications. On the main screen of the menu, there are three default applications available:

- **MobileShop:** allows you to buy and download Brew applications from the WAP browser.
- **Settings:** allows you to change the application settings and to check the memory status.
- **Help:** gives you help for using applications.

Note: You can quickly access this menu by pressing the Down key in standby mode.

Downloading multimedia files

1. Press  when the **MobileShop** icon is selected.

The following options are available:

- **Catalog:** allows you to browse and purchase application.
- **Search:** allows you to search for an application by entering a keyword.
- **About Download:** provides you with the help information about using the **MobileShop** menu.



2. Press  when the **Catalog** option is selected.

You are accessed to the associated web site preset by your service provider and you can browse available applications.

3. Select the application you want to download and follow the instructions on the screen.

Downloaded applications will display on the main screen of the **Brew** menu.

Changing the application settings



1. Select the **Settings** icon using the Left or Right key and press .
2. Select a setting option using the Up or Down key and press .

The following options are available:

- **Order Apps:** allows you to change the order of the downloaded applications.
- **Move Apps:** allows you to move an application to another folder.
- **Manage Apps:** shows the amount of the memory used for downloaded applications.
- **Main Menu View:** allows you to change the view mode of the main menu screen.
- **Screen Savers:** allows you to use one of screen savers downloaded.
- **View Log:** shows the records of your browsing and downloading.

3. When you have finished, press the **C** or  key.

Viewing help information

1. Select the **Help** icon using the Left or Right key and press .
2. Select a help item using the Up or Down key and press .
3. Press the Up or Down key to scroll through the information.
4. To go back to the main help screen, press  or **C** key.

Ringtone *(Menu 8-3)*

In this menu, you can download ring tones and melodies from the WAP browser and play the downloaded contents.

Download New Ringtone *(Menu 8-3-1)*

Selecting this menu loads the WAP page preset by your service provider so that you can download a variety of ring tones and melodies.

Saved Ringtones *(Menu 8-3-2)*

In this menu, you can review ring tones or melodies you have downloaded.

Scroll to the item you want and press the **Save** soft key to play it.

To remove the item, press the **Erase** soft key.

Note: You can also access the **Ringer** menu (**Menu 7-1-1**) to use or erase the downloaded ring tones.

Animation *(Menu 8-4)*

In this menu, you can download animation images from the WAP browser and play the downloaded contents.

Download New Animation *(Menu 8-4-1)*

Selecting this menu loads the WAP page preset by your service provider so that you can download a variety of animation images.

Saved Animation *(Menu 8-4-2)*

In this menu, you can review animated images you have downloaded.

Scroll to the item you want and press the **Select** soft key to play it.

To remove the item, press the **Erase** soft key.

Note: You can also access the **Image box** menu (**Menu 7-2-1**) to use or erase the downloaded animation items.

Voice Portal *(Menu 8-5)*

This menu allows you to access your service provider's voice-activated service. You can get headline news, get information on movies, the weather, finance, traffic, or restaurants in many cities, plus other features; it's similar to the kind of content that's available on a web portal.

Note: Voice Portal is a network feature. Please contact your service provider for further details.

SMS INFO *(Menu 8-6)*

You can send an SMS query to receive information you want from the web server. A variety of topics are available, such as news, sports, entertainment, fun, finance, and astrology.

Once you select a topic, your phone sends a query with the code associated with the selected topic, and the server will send you the requested information in an SMS message.

GPS *(Menu 8-7)*

From the **GPS** menu, you can access the GPS feature, which is a handset-based positioning technology, provided by your service provider.

To determine a location, the phone sends and receives signals to and from a location server on the network. After taking readings from GPS satellites and nearby cellular base stations, the server will perform calculations and tell the phone the appropriate position information.

Voice Navigation *(Menu 8-7-1)*

You can use the Voice Navigation service, which guides you by voice to your destination, from your current position.

When you select this menu, the preset number of the service dials. Follow the voice prompts from the network.

Speed Traps Detector *(Menu 8-7-2)*

You can use the Speed trap detection service, which alerts you to fixed speed camera traps or laser traps, according to your current position.

Selecting this menu dials the preset number of the service and activates the detection service for you. The alert will come in as an incoming call. When you answer the call, the system alerts you to the presence of the speed trap.

Where Is My Kid *(Menu 8-7-3)*

Using this menu, you can use the GPS child locator, which enables you to track your child via the Wireless Web.

Selecting this menu loads the preset website and then you can register the number of the phone you want to track. For further details, contact your service provider.

Emergency Button *(Menu 8-7-4)*

When in trouble, you can place an SOS call to the emergency center by selecting this menu.

Even if you cannot provide any information on your location, the emergency center pinpoints your position and sends the emergency service to you.

Note: This service is available 24 hours a day.

What's new? *(Menu 8-8)*

Selecting this menu loads the WAP page preset by your service provider so that you can get information about your service provider's latest offerings, such as downloads, pricing plans, entertainment, technical help, and customer services.

Camera

Using the camera module built into your phone, you can take photos of people or events while on the move. You can send photos to other people using a message or set photos as a Wallpaper image or an image to be displayed when you turn on or off the phone.

You can also record a video by using your phone as a camcorder.

Note: You can quickly enter this menu by pressing the  key on the right side of the phone in Standby mode.

CAUTION:

- Do not take photos of people without their permission.
- Do not take photos in a place where cameras are not allowed.
- Do not take photos in a place where you may interfere with another person's privacy.

Take photo *(Menu 9-1)*

The camera produces JPEG photos.

Note: When you take a photo in direct sunlight or in bright conditions, shadows may appear on the photo.

Taking a photo with the phone open

1. In Standby mode, press and hold the  key on the right side of the phone.

The image to be captured appears on the display.

2. Adjust the image by aiming the camera at the subject.

To	Press the
flip the image vertically	▲ key.
view the mirror image	▼ key.
zoom in or out	Left or Right key.
change the image brightness	Up or Down Key.
view the image in actual size	0 key.
use the options	the Option soft key. See page 122.

Note: If resolution is set as high, zooming cannot be used.

4. Press the **Capture** soft key or  key to take the photo.

When you are taking multi-shot images, the camera takes photos successively.

5. Press the **Save** soft key.

To discard the photo and go back to Capture mode, press the **Cancel** soft key.

6. Enter the photo name you want.

For details about entering characters, see page 37.

7. Press the **OK** soft key.

The phone saves the photo(s) in the **Photo album** menu (**Menu 9-3**) and returns to Capture mode.

Using the options in Capture mode

When you press the **Option** soft key in Capture mode, the following options are available for the current shot:

Video Mode

Selecting this option switches the phone to Record mode. See page 124.

Flash

The following options are available:

Off: allows you to turn off the flash.

This Shot only: allows you to turn on the flash for the current shot. After you take a photo, the flash turns off.

Always On: allows you to use the flash when you take a photo.

Self timer

You can set the camera to take a photo at a predefined time. You can view the timer icon on the bottom line of the display. When you press the  key or the **Capture** soft key, the timer starts counting down.

Multi shot

This option allows you to take successive action stills up to seven shots. Select the interval between shots, **Off**, **Short**, **Normal**, or **Long**. After taking photos, the phone automatically saves them.

Brightness

You can adjust the brightness of the image. When **Auto** is selected, the phone automatically determines the setting.

Fun frames

This option allows you to use a decorated frame with the photo. Press the Navigation keys to find the frame format you want to use.

ColorTones

This option allows you to change the color tone or apply special effects to the photo.

Resolution

This option allows you to select an image resolution.



Note: The **High** and **Medium** options are available only in Single Shot mode.





Taking a photo with the phone closed

1. When the phone is closed, press and hold the  key on the right side of the phone.

The image to be captured displays on the external display.

2. Adjust the image by aiming the camera module.

To use the options, press the  key until the option icon is selected. You can change the settings by pressing the  key. The following options are available:

- : allows you to flip the image vertically.
- : allows you to adjust the brightness of the image.
- : allows you to select the image quality.
- : allows you to enlarge the image.

- Press the  key to take the photo.

The phone saves the photo in the **Photo album** menu (**Menu 9-3**) and returns to Capture mode.

Record video *(Menu 9-2)*

To record a video:

- Accessing the **Record video** menu turns on the camera.

The image to be captured appears on the display.

- Adjust the image by aiming the camera at the subject.

3. To	Press the
flip the image vertically	▲ key.
view the mirror image	▼ key.
zoom in or out	Left or Right key.
change the brightness of the image	Up or Down key.
use the options	the Option soft key. For details, see page 125.

- Press the **Record** soft key or the  key to start recording.
- When you have finished, press the **Stop** soft key.

Otherwise, the phone will automatically stop when the recording time expires.

- Press the **Save** soft key.

You can review your recording by pressing the **Review** soft key.

- Enter the video name you want.

For further details about entering characters, see page 37.

- Press the **OK** soft key.

The phone saves the video in the **Video album** menu (**Menu 9-4**), and returns to Record mode.

Using the options in Record mode

When you press the **Option** soft key in Record mode, the following options are available:

Photo Mode

Selecting this option switches the phone to Capture mode. See page 120.

Voice REC.

This option allows you to record audio with the video.

Self Timer

You can set the phone to start a video at a predefined time. You can view the timer icon on the bottom line of the display. When you press the **Record** soft key or the  key, the timer starts counting down.

Brightness

You can adjust the brightness of the image. When **Auto** is selected, the phone automatically determines the setting.

ColorTones

This option allows you to change the color tone or apply a special effect to the video.

Photo album *(Menu 9-3)*

In this menu, you can review the photos you have taken. By default, your phone displays the last photo you took on the full screen, Expand mode. Use the Left and Right keys to scroll through the photos.

To view the photos as small images, press the **Thumbnail** soft key. In this mode, you can scroll through the photos by using the Navigation keys. To go back to Expand mode, press **Expand** soft key.

Using the photo options

Press the **Option** soft key to use the following options:

Note: The available options are different, depending on the current view mode, Thumbnail or Expand mode.

Send MMS

This option allows you to send the photo to another person's phone. For further details about sending MMS, see page 129

Assign

This option allows you to set the photo as your Wallpaper for the idle screen or an image to be displayed when you turn on or off the phone.

Rename

This option allows you to change the name of the photo.

Protect

This option allows you to protect the photo so that other people cannot access the photo without your lock code.

Erase

This option allows you to erase the photo.

Erase All

This option allows you to erase all of the photos stored in the phone.

Photo Info

This option shows you information about the current photo, such as the name, the time and date it was taken, image size, and image quality.

Video album *(Menu 9-4)*

In this menu, you can play the video files you recorded. When you access this menu, the still image of the last video you recorded displays.

To play a video:

1. Press the Left or Right key to scroll to the video you want to view.

2. To	Press the
start	Play soft key.
stop	right soft key.
return to Standby mode	 key.

Using the video options

Press the **Option** soft key on the Video album screen to use the following options:

Rename

This option allows you to change the name of the video.

Protect

This option allows you to protect the video so that other people cannot access the video without your lock code.

Erase

This option allows you to erase the video.

Erase All

This option allows you to erase all of the videos.

Video Info

This option shows you information about the current video, such as the name, the time and date it was recorded, video size, and image quality.

MMS *(Menu 9-5)*

In this menu, you can send a photo to other people as a part of an MMS message.

New Photo *(Menu 9-5-1)*

You can take a new photo and then create and send an MMS message. Selecting this menu turns on the camera and switches to Capture mode.

1. After adjusting the image, press the **Capture** soft key to take a photo.

For more information about the options available in the camera, see page 120.

2. Press the **Save** soft key.
3. Enter a photo name and press the **OK** soft key.

A new message screen containing the taken photo appears.

4. When the **Send To** field highlights, press the **Menu** soft key.

Note: You can select a address type, Send To, Cc, or Bcc, by pressing the Left or Right key.

5. Select **Phonebook** to retrieve a phone number or an e-mail address from your Phone book, or **Input** to enter one.
6. Choose a number or an address or enter one, and then press the **OK** soft key.
7. Press the Down key to move to the **Subject** field and press the **Edit** soft key.

8. Enter a subject and press the **OK** soft key.

9. Press the Down key to move the **Picture** field and press the **Menu** soft key.

The following options are available:

- **Take Photo:** allows you to take a new photo using the camera.
- **Album:** allows you to select a photo from the Photo album.
- **Saved Img:** allows you to select one of images you have received by MMS message.
- **Erase:** remove the image from the slide.

10. Press the Down key to move the **Message** field and press the **Edit** soft key.

11. Enter a message text and press the **OK** soft key.

12. Press the Down key to move to the **Sound** field and press the **Menu** soft key.

The following options are available:

- **Voice Rec:** allows you to record a new voice memo.
- **Voice Memo:** allows you to select one of voice memos you have recorded.
- **Melody:** allows you to select one of the default melodies.
- **Saved Snd:** allows you to select one of sounds you have received by MMS message.
- **Erase:** remove the sound from the slide.

13. Select an option and then record a memo or select a sound.

14. If you want to add or remove a slide, move to the **Slide** field and press the **Menu** soft key.

The following options are available:

- **Add:** adds a new slide.
- **Erase:** erases any added slides.
- **Duration:** allows you to set the length of time the slide displays.

15. When you have finished the MMS message, press the **OK** soft key.

The following options are available:

- **Preview:** shows the message you created.
- **MMS Edit:** allows you to change the message.
- **Options:** allows you to set message options.
- **Save in Draft:** saves the message in the Draft box.

16. When you are satisfied, press the **OK** soft key.

The phone displays your message.

17. Press the **Send** soft key to send it.

Album *(Menu 9-5-2)*

You can create and send an MMS message using one of photos stored in Photo album. Selecting this menu opens the Photo album screen.

1. Scroll to the photo you want by pressing the Left or Right key and press the **Select** soft key.

A new message screen containing the selected photo appears.

2. Follow from step 4 on page 129 to create and send the message.

Settings *(Menu 9-6)*

This menu allows you to change the default settings of the options for using the camera.

The following options are available:

Resolution: allows you to adjust the resolution of the image. You can select either **High:640*480**, **Medium:320*240**, **Full:160*120**, or **Low:128*96**.

Fun frames: allows you to use a frame with the photo. Press the Navigation keys to find the frame format you want to use.

Color tones: allows you to change the color tone or apply a special effect to the image.

Shutter sound: allows you select the tone that sounds when you press the **Capture** soft key or  key.

Quality: allows you to change the image quality. You can select either **Fine**, **Normal**, or **Economy**.

Memory status *(Menu 9-7)*

You can check the amount of the memory being used and the memory remaining for the Camera feature.

The display shows the total, used, and free space.

Health and safety information

Exposure to radio frequency (RF) signals

Your wireless phone is a radio transmitter and receiver. It is designed and manufactured not to exceed the emission limits for exposure to radio frequency (RF) energy set by the Federal Communications Commission (FCC) of the U.S. Government. These limits are part of comprehensive guidelines and establish permitted levels of RF energy for the general population. The guidelines are based on the safety standards that were developed by independent scientific organizations through periodic and through evaluation of scientific studies.

The standards include a substantial safety margin designed to assure the safety of all persons, regardless of age and health.

The exposure standard for wireless phones employs a unit of measurement known as Specific Absorption Rate (SAR). The SAR limit set by the FCC is 1.6W/kg.*

*. In the U.S. and Canada, the SAR limit for mobile phones used by the public is 1.6 watts/kg (W/kg) averaged over one gram of tissue. The standard incorporates a substantial margin of safety to give additional protection for the public and to account for any variations in measurements.

SAR tests are conducted using standard operating positions specified by the FCC with the phone transmitting at its highest certified power level in all tested frequency bands. Although the SAR is determined at the highest certified power level, the actual SAR level of the phone while operating can be well below the maximum value. This is because the phone is designed to operate at multiple power levels so as to use only the power required to reach the network. In general, the closer you are to a wireless base station antenna, the lower the power output of the phone.

Before a new model phone is available for sale to the public, it must be tested and certified to the FCC that it does not exceed the limit established by the government-adopted requirement for safe exposure. The tests are performed in positions and locations (e.g., at the ear and worn on the body) as required by the FCC for each model. While there may be differences between the SAR levels of various phones and at various positions, they all meet the government requirement.

The FCC has granted an Equipment Authorization for this model phone with all reported SAR levels evaluated as in compliance with the FCC RF exposure guidelines. SAR information on this model phone is on file with the FCC and can be found under the Display Grant section of <http://www.fcc.gov/oet/fccid> after searching on FCC ID printed in the label on the phone.

FCC certification information for this model phone is attached separation paper.

For body operation

For body worn operation, this model phone has been tested and meets the FCC RF exposure guidelines when used with a Samsung-supplied or approved accessory designated for this product or when used with an accessory that contains no metal and that positions the handset a minimum from the body. The minimum distance for this model phone is written in the FCC certification information from the body. None compliance with the above conditions may violate FCC RF exposure guidelines.

For more Information concerning exposure to radio frequency signals, see the following websites:

Federal Communications Commission (FCC) <http://www.fcc.gov/oet/rfsafety>

Cellular Telecommunications Industry Association (CTIA): <http://www.wow-com.com>

U.S. Food and Drug Administration (FDA) <http://www.fda.gov/cdrh/consumer>

World Health Organization (WHO) <http://www.who.int/peh-emf/en>

Precautions when using batteries

- Never use any charger or battery that is damaged in any way.
- Use the battery only for its intended purpose.
- If you use the phone near the network's base station, it uses less power; talk and standby time are greatly affected by the signal strength on the cellular network and the parameters set by the network operator.

Battery charging time depends on the remaining battery charge and the type of battery and charger used. The battery can be charged and discharged hundreds of times, but it will gradually wear out. When the operation time (talk time and standby time) is noticeably shorter than normal, it is time to buy a new battery.

- If left unused, a fully charged battery will discharge itself over time.
- Use only Samsung-approved batteries and recharge your battery only with Samsung-approved chargers. When a charger is not in use, disconnect it from the power source. Do not leave the battery connected to a charger for more than a week, since overcharging may shorten its life.
- Extreme temperatures will affect the charging capacity of your battery: it may require cooling or warming first.

Do not leave the battery in hot or cold places, such as in a car in summer or winter conditions, as you will reduce the capacity and lifetime of the battery. Always try to keep the battery at room temperature. A phone with a hot or cold battery may temporarily not work, even when the battery is

fully charged. Li-ion batteries are particularly affected by temperatures below 0 °C (32 °F).

- Do not short-circuit the battery. Accidental short-circuiting can occur when a metallic object (coin, clip or pen) causes a direct connection between the + and – terminals of the battery (metal strips on the battery), for example when you carry a spare battery in a pocket or bag. Short-circuiting the terminals may damage the battery or the object causing the short-circuiting.
- Dispose of used batteries in accordance with local regulations. Always recycle. Do not dispose of batteries in a fire.

Road safety

Your wireless phone gives you the powerful ability to communicate by voice, almost anywhere, anytime. But an important responsibility accompanies the benefits of wireless phones, one that every user must uphold.

When driving a car, driving is your first responsibility. When using your wireless phone behind the wheel of a car, make sure that you are following the special regulations in a given area or country.

Operating environment

Remember to follow any special regulations in force in any area and always switch your phone off whenever it is forbidden to use it, or when it may cause interference or danger.

When connecting the phone or any accessory to another device, read its user's guide for detailed safety instructions. Do not connect incompatible products.

As with other mobile radio transmitting equipment, users are advised that for the satisfactory operation of the equipment and for the safety of personnel, it is recommended that the equipment should only be used in the normal operating position (held to your ear with the antenna pointing over your shoulder).

Electronic devices

Most modern electronic equipment is shielded from radio frequency (RF) signals. However, certain electronic equipment may not be shielded against the RF signals from your wireless phone. Consult the manufacturer to discuss alternatives.

Pacemakers

Pacemaker manufacturers recommend that a minimum distance of 15 cm (6 inches) be maintained between a wireless phone and a pacemaker to avoid potential interference with the pacemaker. These recommendations are consistent with the independent research and recommendations of Wireless Technology Research.

Persons with pacemakers:

- Should always keep the phone more than 15 cm (6 inches) from their pacemaker when the phone is switched on
- Should not carry the phone in a breast pocket
- Should use the ear opposite the pacemaker to minimize potential interference

If you have any reason to suspect that interference is taking place, switch your phone immediately off.

Hearing aids

Some digital wireless phones may interfere with some hearing aids. In the event of such interference, you may wish to consult your hearing aid manufacturer to discuss alternatives.

Other medical devices

If you use any other personal medical devices, consult the manufacturer of your device to determine if it is adequately shielded from external RF energy. Your physician may be able to assist you in obtaining this information. Switch your phone off in health care facilities when any regulations posted in these areas instruct you to do so. Hospitals or health care facilities may be using equipment that could be sensitive to external RF energy.

Vehicles

RF signals may affect improperly installed or inadequately shielded electronic systems in motor vehicles. Check with the manufacturer or its representative regarding your vehicle.

You should also consult the manufacturer of any equipment that has been added to your vehicle.

Posted facilities

Switch your phone off in any facility where posted notices require you to do so.

Potentially Explosive Environments

Switch your phone off when in any area with a potentially explosive atmosphere and obey all signs and instructions. Sparks in such areas could cause an explosion or fire resulting in bodily injury or even death.

Users are advised to switch off the phone while at a refuelling point (service station). Users are reminded of the need to observe restrictions on the use of radio equipment in fuel depots (fuel storage and distribution areas), chemical plants or where blasting operations are in progress.

Areas with a potentially explosive atmosphere are often but not always clearly marked. They include below deck on boats, chemical transfer or storage facilities, vehicles using liquefied petroleum gas (such as propane or butane), areas where the air contains chemicals or particles, such as grain, dust or metal powders, and any other area where you would normally be advised to turn off your vehicle engine.

Emergency calls

This phone, like any wireless phone, operates using radio signals, wireless and landline networks as well as user-programmed functions, which cannot guarantee connection in all conditions. Therefore, you should never rely solely on any wireless phone for essential communications (medical emergencies, for example).

Remember, to make or receive any calls the phone must be switched on and in a service area with adequate signal strength. Emergency calls may not be possible on all wireless phone networks or when certain network services and/or phone features are in use. Check with local service providers.

To make an emergency call:

1. If the phone is not on, switch it on.
2. Key in the emergency number for your present location (for example, 100 or any other official emergency number). Emergency numbers vary by location.
3. Press .

If certain features are in use (call barring, for example), you may first need to deactivate those features before you can make an emergency call. Consult this document and your local cellular service provider.

When making an emergency call, remember to give all the necessary information as accurately as possible. Remember that your phone may be the only means of communication at the scene of an accident; do not cut off the call until given permission to do so.

Other important safety information

- Only qualified personnel should service the phone or install the phone in a vehicle. Faulty installation or service may be dangerous and may invalidate any warranty applicable to the device.
- Check regularly that all wireless phone equipment in your vehicle is mounted and operating properly.
- Do not store or carry flammable liquids, gases or explosive materials in the same compartment as the phone, its parts or accessories.
- For vehicles equipped with an air bag, remember that an air bag inflates with great force. Do not place objects, including both installed or portable wireless equipment in the area over the air bag or in the air bag deployment area. If wireless equipment is improperly installed and the air bag inflates, serious injury could result.
- Switch your phone off before boarding an aircraft. The use of wireless phones in aircraft may be dangerous to the operation of the aircraft, and is illegal.
- Failure to observe these instructions may lead to the suspension or denial of telephone services to the offender, or legal action, or both.

Care and maintenance

Your phone is a product of superior design and craftsmanship and should be treated with care. The suggestions below will help you fulfill any warranty obligations and allow you to enjoy this product for many years.

- Keep the phone and all its parts and accessories out of the reach of small children's.
- Keep the phone dry. Precipitation, humidity and liquids contain minerals that will corrode electronic circuits.
- Do not use the phone with a wet hand. Doing so may cause an electric shock to you or damage to the phone.
- Do not use or store the phone in dusty, dirty areas, as its moving parts may be damaged.
- Do not store the phone in hot areas. High temperatures can shorten the life of electronic devices, damage batteries, and warp or melt certain plastics.
- Do not store the phone in cold areas. When the phone warms up to its normal operating temperature, moisture can form inside the phone, which may damage the phone's electronic circuit boards.
- Do not drop, knock or shake the phone. Rough handling can break internal circuit boards.
- Do not use harsh chemicals, cleaning solvents or strong detergents to clean the phone. Wipe it with a soft cloth slightly dampened in a mild soap-and-water solution.

Health and safety information

- Do not paint the phone. Paint can clog the device's moving parts and prevent proper operation.
- Do not put the phone in or on heating devices, such as a microwave oven, a stove or a radiator. The phone may explode when overheated.
- Use only the supplied or an approved replacement antenna. Unauthorized antennas or modified accessories may damage the phone and violate regulations governing radio devices.
- If the phone, battery, charger or any accessory is not working properly, take it to your nearest qualified service facility. The personnel there will assist you, and if necessary, arrange for service.

Glossary

Air Time - Actual time spent talking on the wireless phone. Most carriers bill customers based on how many minutes of airtime they use each month.

Antenna - A device for transmitting or receiving signals. The size and shape of antennas is determined, in part, by the frequency of the signal they receive. Wireless phones and the base station must have antennas.

Base Station - The fixed radio transmitter/receiver that maintains communications with mobile radio telephones within a given area. (Typically called a cell or cell site)

CDMA - (Code Division Multiple Access) A spread-spectrum approach to digital transmission. With CDMA, each conversation is digitized and then tagged with a code. The mobile phone deciphers only a particular code to pick the right conversation off the air. The transmitted signal is just above noise level across the available bandwidth.

Channel - Communications signals transmit along paths called channels.

Codec Coder/Decorder - Compression & decompression.

Deactivation - The process of rendering a wireless phone inactive.

DTMF - (Dual-Tone Multi-Frequency) You send DTMF signals when you enter numbers by pressing the digit keys.

EVRC - (Enhanced Variable Rate Codec) EVRC is a new global standard for compressing and decompressing voice signals. EVRC uses a lower bit rate (the number of bits sent per second) than existing CDMA vocoders, while providing significant improvements in voice quality. This technology enables your phone to provide superb voice quality while benefiting from the ability to process more cellular voice calls using less bandwidth than the voice codecs in CDMA networks today.

Frequency - A measure based on time, as one or more waves per second, in an electrical or light wave information signal. A signal's frequency is stated in cycles-per-second or Hertz (Hz).

Hands-Free - A feature that permits a driver to use a wireless phone without lifting or holding the handset - an important safety feature for automobiles, tractors and most other motorized vehicles.

LCD - (Liquid Crystal Display) Commonly used to refer to the screen display on the wireless phone.

Prepend - The addition of a prefix, such as an area code, to a phone number.

RF - Radio Frequency

Roaming - The ability to use a wireless phone to make and receive calls in places outside of the home service area.

Service Charge - The amount paid each month to receive wireless service.

Standby Time - The amount of time a fully charged wireless portable or transportable phone can be on and idle without being in use. (See Talk Time)

Talk Time - The length of time a person can talk on a portable or transportable wireless phone without recharging the battery.

Vocoder - Voice Coder. A device used to convert speech into digital signals.

Wireless - Radio-based Systems that allow transmission of telephone or data signals through the air without a physical connection, such as a metal wire (copper) or fiber optic cable.

A

- Accessories 9
- Add
 - from Standby mode 59
 - into an existing entry 59
 - using a memo 61
 - using a number 57
 - using an e-mail address 60
- Adjusting the volume during a call 32
- Air time 53
- Alarm 80
- Alert
 - connect 98
 - disconnect 98
 - fade 99
 - folder 99
 - hour alert 99
 - minute Beep 98
 - service area 98
- Animation 116
- Answer mode 103
- Auto retry 103

B

- Backlight 15, 102
- Banner 101
- Battery
 - charging 19
 - installing 17
 - low battery indicator 20
 - removing 18

C

- Calculator 83
- Calendar 77
- Calls
 - answering 33
 - emergency 26
 - ending 26

- forwarding 36
- from Phonebook 27
- incoming 52
- making 25
- missed 34, 51
- outgoing 53
- recent call 27
- silencing 33
- three-way 35
- waiting 36
- Camera 120
- Characters, entering 37
- Clear memory 107
- Countdown 86

D

- Data/Fax Mode 108
- Dialing
 - pause 30
 - prepend 28
 - speed 29
- Display
 - Icons 13
- Display 100
 - backlight 102
 - language 102
 - layout 13
- DTMF tones, send 35

E

- Emergency # 105
- External clock 102

F

- Find
 - by entry number 56
 - by group 56
 - by name 54
- Flash 16

G

- Games 88

I

- Image box 100
- In-call option 34
- Installing battery 17
- Internet Portal 110

K

- Key tone 98
- Keys
 - description 11
 - location 10

L

- Language, select 102
- Lock code, change 105
- Lock mode 24
- Low battery indicator 20

M

- Memo pad 87
- Menus
 - accessing 44
 - list 46
 - shortcuts 45
- Message
 - draftbox 67
 - inbox 64
 - new message 63
 - outbox 66
 - setup 74
 - templates 76
 - writing 63
- MMS 68
- My phone # 62

N

- Navigating the browser 110

P

- Phone
 - display 13

- keys 11
- layout 10
- reset 107
- unpacking 9
- Phone lock 104
- Phonebook
 - adding entry 57
 - finding entry 54
 - group set 62
- Photo album 126
- Power Save mode 23

R

- Removing the battery 18
- Resetting phone 107
- Restriction 106

S

- Safety
 - information 133
 - precautions 7
- Scheduler 77
- Service LED 102
- Service light 15
- Set time 81
- Silent mode 24
- SMS info 117
- Soft keys 22
- Sounds 96
- Standby mode 23
- Switching on/off phone 20

T

- T9 Word, T9 Hebrew 38
- Talk mode 23
- To do list 84
- Today 83

V

- VAS 110
- Video album 127
- Voice Answer 93
- Voice mail 73

Index

Voice memo 91
Voice portal 117

W

Wallpaper 101
What's new? 119
World time 85
Writing new message 63

SCH-X839 Quick reference card

Basic Operation

Make a call	Phone number +
End a call	
Receive a call	or open the phone
Adjust the key volume	(in Standby mode) ▲/▼ on the left side
Adjust the voice volume	(during a call) ▲/▼ on the left side
Redial the last call	Hold
Switch to Silent mode	(in Standby mode) Hold #
Take a photo	<ul style="list-style-type: none"> With the phone open Hold the Camera key + Capture Save + Enter a picture name + OK With the phone closed Hold the Camera key + the Camera key

Internal Phone book

Store a new number into memory	Phone number + Save + Select + Name + OK + Choose Category + Select + Up/Down (Name/Location/Home/Office/Mobile/Pager/Fax/E-mail1/E-mail2/URL/Memo/Speed dial/Group/Ringer/Caller Image) + Edit and enter information or Left/Right + Save
Speed dial	Location number + hold the last digit
Scan memories	Right + Left/Right/Up/Down + OK

Licensed by QUALCOMM incorporated under one or more of the following Patents.
 U.S Patent No. 4,901,307 5,056,109 5,099,204
 5,101,501 5,103,459 5,107,225
 5,109,390

Main Menu (To access, press the Menu soft key)

1: Calls	1: Missed 2: Incoming 3: Outgoing 4: Air Time	6: Voice Tools	1: Voice Memo 2: Voice Answer
2: Phone book	1: Find 2: Add 3: Group Set 4: My Phone #	7: Settings	1: Sounds 2: Display 3: Auto retry 4: Answer mode 5: Security 6: Data/fax Mode 7: Memory status
3: Message	1: Text MSG 2: MMS 3: Voice Mail 4: Msg Setup	8: VAS	1: Internet Portal 2: Games & App. 3: Ringtone 4: Animation 5: Voice Portal 6: SMS INFO 7: GPS 8: What's new?
4: Scheduler	1: Calendar 2: Alarm Set 3: Set time 4: Calculator 5: Today 6: To Do List 7: World time 8: Countdown 9: Memo pad	9: Camera	1: Take photo 2: Record video 3: Photo album 4: Video album 5: MMS 6: Settings 7: Memory status
5: Games	1: Chicken run 2: Mobile cop		