



Portable Air Conditioners Condensate Pump Kit

Models: 700870, 700875, 700877

User's & Installation Manual

Component Parts

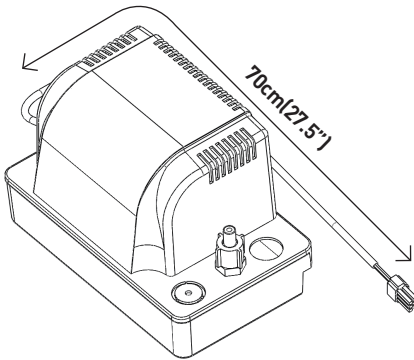

Figure 1 – condensate pump

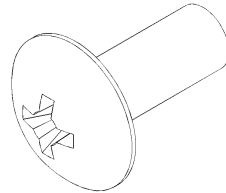

Figure 2 – bolt two piece

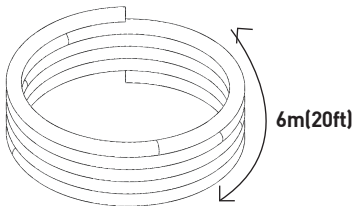

Figure 3 – hose.01

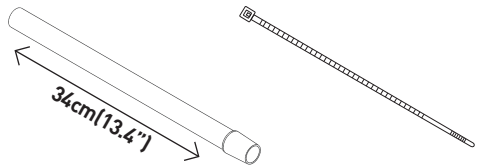

Figure 4 – hose.02

Figure 4-A – cable tie

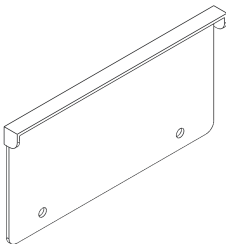

Figure 5 – condensate pump clamp part.01

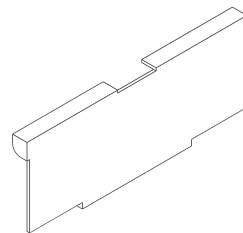

Figure 6 – condensate pump clamp part.02

ASSEMBLY

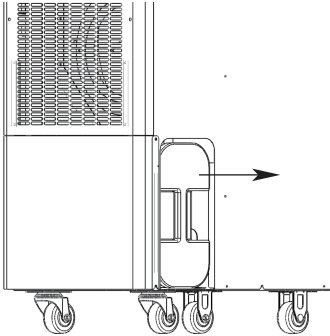

Figure 7 – Front and Right Side View

1. Turn off the air conditioner.
2. Remove the water tank.

1. Install the condensate pump clamp part2 (figure 6) on the hole of condensate pump guide
NOTE: Confirm the direction is correct

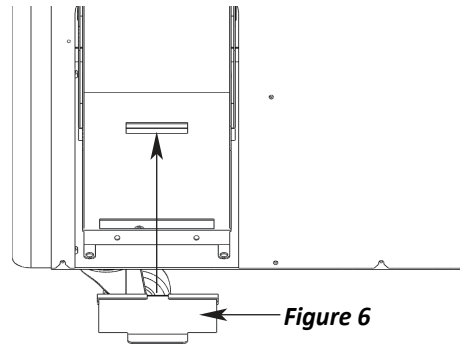

Figure 8 – Right Side View

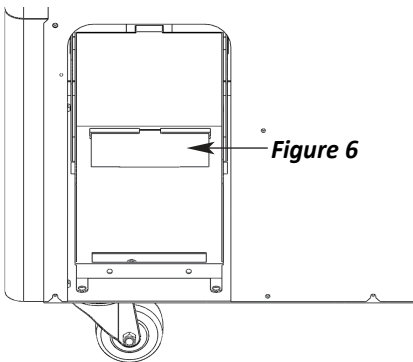

Figure 9 – Right Side View

1. After install the condensate pump clamp part2, confirm it is same as Figure 6

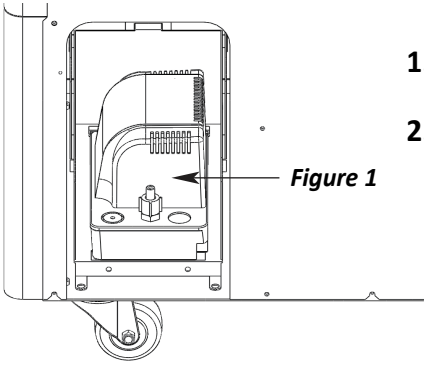

Figure 10 – Right Side View

1. Install the condensate pump (figure 1) onto the condensate pump guide.
2. Confirm the condensate pump clamp part2 (figure 6) is positioned properly.

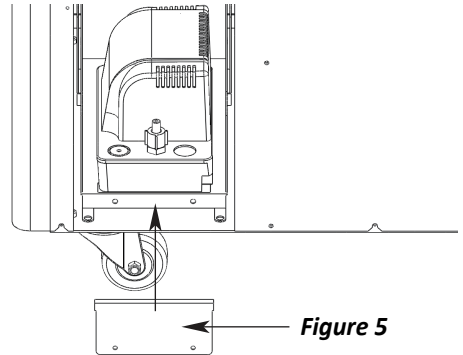

Figure 11 – Right Side View

1. Install the condensate pump clamp part1 (figure 5) onto the condensate pump
2. Confirm it is installed as same as figure 12.

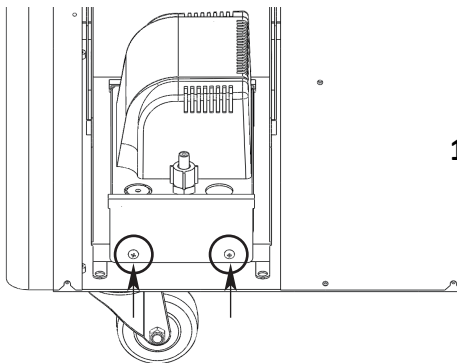

Figure 12 – Right Side View

1. Tighten 2 Screws using a screwdriver.

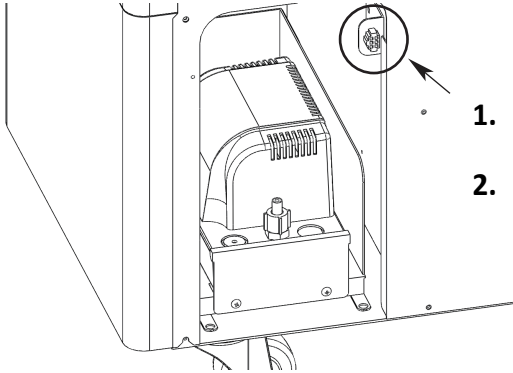

Figure 13 – Right Side View

1. Remove the cap on the terminal in the Figure 13.
2. Connect the wire of the condensate pump to the terminal.

1. Connect the hose1 (figure 3) to the condensate pump as you see in the Figure 14.

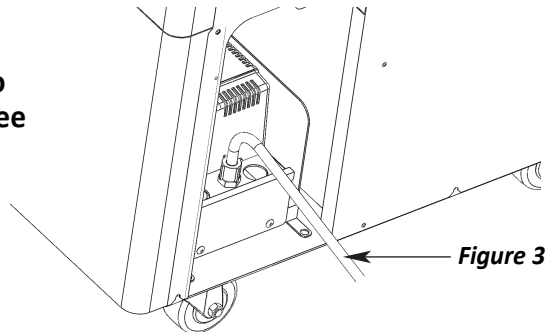

Figure 14 – Right Side View

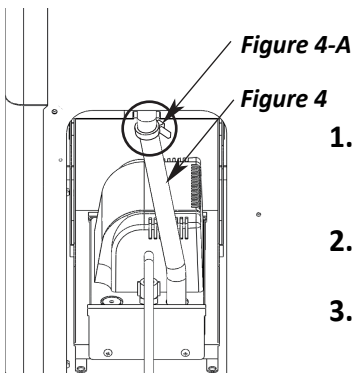

Figure 15 – Right Side View

1. Connect the hose2 (figure 4) between the condensate pump and upper drain pipe as you see in the Figure 15.
2. Tighten the cable tie (figure 4-A) on the upper part of the hose.02
3. Turn on the air conditioner then condensate pump operates automatically.