

RAID Subsystem DVA-16K

DVA-16K SCSI Premium Series



BOSCH

en Installation Manual

Table of Contents

1	Warnings and Certifications	6
1.1	Warning	6
1.2	Safety Precautions	6
1.3	Certifications	6
2	Introduction	8
2.1	Product Overview	8
2.2	Management	9
2.3	Best Practices	9
2.3.1	Avoiding Points of Failure	9
2.3.2	Dual-Redundant Data Paths	9
2.3.3	ID Mapping	9
2.4	Enclosure Chassis	10
2.4.1	Chassis Overview	10
2.4.2	Physical Dimensions	10
2.4.3	Front Panel Overview	10
2.4.4	Hard Drive Numbering	11
2.4.5	Rear Panel Overview	11
2.4.6	Backplane Board	12
2.5	Subsystem Components	12
2.5.1	LCD Panel	12
2.5.2	Drive Trays	13
2.5.3	The RAID Controller Module	13
2.5.4	Controller Module Interfaces	13
2.5.5	DIMM Module	14
2.5.6	Battery Backup Unit (BBU)	14
2.5.7	Power Supply Units	15
2.5.8	Cooling Modules	15
2.6	Subsystem Monitoring	16
2.6.1	I ² C bus	16
2.6.2	LED Indicators	16
2.6.3	Firmware (FW) and Bosch RAIDWatch GUI	16
2.6.4	Audible Alarms	16
2.7	Hot-swappable Components	17
2.7.1	Hot-swap Capabilities	17
2.7.2	Components	17
2.7.3	Normalized Airflow	17
3	Hardware Installation	18
3.1	Introduction	18
3.2	Installation Prerequisites	18
3.3	Safety Precautions	18
3.3.1	Precautions and Instructions	18
3.3.2	Static-free Installation	19
3.4	General Installation Procedure	19
3.4.1	Installation Procedure Flowchart	19
3.5	Unpacking the Subsystem	20
3.6	Rack/Cabinet Installation	20
3.7	Drive Tray Installation	20

4	Subsystem Monitoring	23
4.1	Subsystem Monitoring Overview	23
4.2	Status Indicating LEDs	24
4.2.1	Brief Overview of the LEDs	24
4.2.2	LCD Panel	24
4.2.3	Drive Tray LEDs	25
4.2.4	Controller Module LEDs	26
4.2.5	LAN Port LEDs	27
4.2.6	BBU Module LED	27
4.2.7	PSU LEDs	28
4.2.8	Cooling Module LEDs	28
4.3	Audible Alarm	29
4.3.1	Default Threshold Values	29
4.3.2	Failed Devices	29
4.4	Monitoring	30
5	Subsystem Connection and Operation	31
5.1	SCSI Connection Overview	31
5.1.1	SCSI Cables	31
5.1.2	SCSI Port on the Controller Rear Panel	31
5.1.3	SCSI Termination	31
5.2	Host Connection Topology	32
5.2.1	Single Host	32
5.2.2	Dual Hosts	33
5.3	Daisy Chain	34
5.3.1	Daisy Chain Topology	34
5.3.2	Daisy Chain Procedures	35
5.4	Power On	35
5.4.1	Check List	36
5.4.2	Power On Procedure	36
5.4.3	Power On Status Check	36
5.4.4	LCD Screen	37
5.5	Power Off Procedure	38
6	Subsystem Maintenance	39
6.1	Overview	39
6.1.1	About Subsystem Maintenance	39
6.1.2	General Notes on Component Replacement	39
6.2	Replacing Controller Module Components	39
6.2.1	Controller Module Maintenance Overview	40
6.2.2	Removing the Controller Module	40
6.2.3	Replacing the Controller Module	40
6.3	DIMM Module Replacement	41
6.3.1	DIMM Module Considerations	42
6.3.2	DIMM Module Replacement Procedure	42
6.4	Replacing a Faulty BBU Module	43
6.4.1	BBU Warnings and Precautions	43
6.4.2	Procedure	43
6.5	Replacing a Faulty PSU Module	44
6.5.1	PSU Module Overview	44
6.5.2	Replacing the PSU Module	45
6.6	Cooling Module Maintenance	47
6.6.1	Cooling Module Overview	47
6.6.2	Replacing a Cooling Module	47
6.7	Replacing a Failed Hard Drive	48
6.7.1	Hard Drive Maintenance Overview	49
6.7.2	Replacing a Hard Drive	49

7	Appendix: Specifications	51
7.1	Technical Specifications	51
7.2	Controller Specifications	52
7.3	Drive Tray Specifications	54
7.4	Power Supply Specifications	54
7.5	Cooling Module Specifications	55
7.6	RAID Management	55
7.7	Fault Tolerance Management	56
8	Appendix: Spare Parts and Accessories	57
8.1	Spare Parts	57
8.2	Accessories	57
9	Appendix: Pin Outs	58
9.1	VHDCI SCSI Port Pin Outs	58
9.2	DB9 Audio Jack Pin Outs	59
9.3	DB9 Audio Jack UPS Cable Pin Outs	60
9.4	Null Modem	60
9.5	Ethernet Port Pin Outs	61
9.6	Main Power	61
10	Index	63

1 Warnings and Certifications

1.1 Warning

- A shielded power cord is required in order to meet FCC emission limits and also to prevent interference with nearby radio and television reception.
- Use only shielded cables to connect I/O devices to this equipment. You are cautioned that changes or modifications not expressly approved by the party responsible for compliance could void your authority to operate the equipment.

1.2 Safety Precautions

Precautions and Instructions

- Prior to powering on the subsystem, ensure that the correct power range is being used.
- The subsystem comes with 16 drive bays. Leaving any of these drive bays empty will greatly affect the efficiency of the airflow within the enclosure, and will consequently lead to the system overheating, which can cause irreparable damage.
- If a module fails, leave it in place until you have a replacement unit and you are ready to replace it.
- Airflow Consideration: The subsystem requires an airflow clearance, especially at the front and rear.
- Handle subsystem modules using the retention screws, eject levers, and the metal frames/face plates. Avoid touching PCB boards and connector pins.
- To comply with safety, emission, or thermal requirements, none of the covers or replaceable modules should be removed. Make sure that all enclosure modules and covers are securely in place during operation.
- Be sure that the rack cabinet into which the subsystem chassis will be installed provides sufficient ventilation channels and airflow circulation around the subsystem.
- Provide a soft, clean surface to place your subsystem on before working on it. Servicing on a rough surface may damage the exterior of the chassis.
- If it is necessary to transport the subsystem, repackage all drives and replaceable modules separately.
- Dual redundant controller models come with two controller modules that must be installed into the subsystem. Single controller modules come with a single controller module and a metal sheet is placed over the lower controller bay at the rear of the subsystem. Since single controller modules cannot be upgraded, this metal sheet should NEVER be removed.

ESD Precautions

Observe all conventional anti-ESD methods while handling system modules. The use of a grounded wrist strap and an anti-static work pad are recommended. Avoid dust and debris in your work area.

1.3 Certifications

FCC (applies in the U.S. and Canada)

FCC Class B Radio Frequency Interference Statement

This equipment has been tested and found to comply with the limits for a Class B digital device, pursuant to Part 15 of the FCC Rules (47 CFR, Part 2, Part 15 and CISPR PUB. 22 Class B). These limits are designed to provide reasonable protection against harmful interference when the equipment is operated in a residential installation. This equipment generates,

uses, and can radiate radio frequency energy and, if not installed and used in accordance with this user's manual, may cause harmful interference to radio communications. However, there is no guarantee that interference will not occur in a particular installation. If this equipment does cause harmful interference to radio or television reception, which can be determined by turning the equipment off and on, you are encouraged to try to correct the interference by one or more of the following measures:

- Reorient or relocate the receiving antenna.
- Increase the separation between the equipment and receiver.
- Connect the equipment into an outlet on a circuit different from that to which the receiver is connected.
- Consult the dealer or an experienced radio/TV technician for help.

This device complies with Part 15 of FCC Rules. Operation is subject to the following two conditions: 1) this device may not cause harmful interference, and 2) this device must accept any interference received, including interference that may cause undesired operation.



This device is in conformity with the EMC.

CB (Certified Worldwide)

This device meets the requirements of the CB standard for electrical equipment with regard to establishing a satisfactory level of safety for persons using the device and for the area surrounding the apparatus. This standard covers only safety aspects of the above apparatus; it does not cover other matters, such as style or performance.

2 Introduction

This manual covers the DVA-16K series of RAID subsystems.

The 3U profile, SCSI-320 to SATA-II, RAID subsystem is capable of a high-performance storage operation that has been specifically designed to meet the rapidly changing demands and needs of today's storage networks. The RAID subsystem is rigorous and durable that can be easily configured and operated.

Fully featured RAID redundancy provides advanced data protection and ensures that the complete range of RAID levels 0, 1(0+1), 3, 5, 10, 30, 50 and JBOD are supported. Complete system redundancy, through fully redundant data paths and hot-swappable devices ensures the overall protection of data. A long list of sophisticated firmware functions (multi-subsystem configuration, dedicated/ global hot-spares, battery protected disk cache, automatic background rebuild, online drive expansion, intelligent drive handling, media scan, task-scheduler, remote and real-time subsystem monitoring, and more). Further the system guarantees the overall availability of valuable data.

System integrators, using the RAID series, will be able to rapidly develop SCSI-320 solutions. This will help save both development time and the associated R&D costs, providing a competitive edge in the marketplace. For users, the modular nature of the series minimizes the total management cost of building a large storage network with a RAID subsystem.

The enhanced 3U RAID storage subsystem chassis is a 3U metal chassis divided into front and rear sections, which are respectively accessed through front and rear panels. Pre-drilled mounting holes in the sides of the 3U RAID subsystem enclosure allow you to attach separately purchased slide rails so that you can install the enclosure into a rack or cabinet. The modular design of the active components facilitates their easy installation and removal. Hot-swap mechanisms are incorporated to eliminate power surges and signal glitches that might happen while removing or installing these modules.

2.1 Product Overview

This manual introduces the SCSI-320 to SATA-II RAID subsystem shown in *Figure 2.1*.



Fig. 2.1 RAID Subsystem

The RAID subsystem comes with two (2) 320MB/second SCSI (SCSI-320) host channels. This high-density subsystem supports up to sixteen (16) hot swappable, SATA-II hard drives in a 3U profile. The core of the subsystem is the RAID controller board with the ASIC266 and a pre-installed 256MB DDR RAM DIMM module with support for capacities up to 1GB. The new SCSI-320 host channel features packet protocol, and its reduction in command overhead provide increased speed without bandwidth issues.

The metal container in which the controller board is pre-installed is referred to as the “controller module.” The controller module is comprised of a PCB board, a rear faceplate, and a metal canister. The controller module is accessed through the rear of the RAID subsystem. A battery backup unit (BBU) is installed in the upper left side of the controller module when viewed from the rear of the subsystem. The BBU is also accessible and hot swappable through the rear panel of the RAID subsystem.

Two (2) dual-stacked VHDCI SCSI connectors connect the RAID controller to single or dual hosts and cascade external devices. Two (2) hot-swappable cooling modules protect the subsystem from overheating, and two (2) hot-swappable power supply unit (PSU) modules pro-

vide constant power to the subsystem. The modular nature of the subsystem and the easy accessibility to all major components ensure the ease of the subsystem maintenance.



NOTICE!

On receiving and unpacking your subsystem, please check the package contents against the included Unpacking Checklist. If any modules are missing, please contact your subsystem vendor immediately.

2.2

Management

The RAID subsystem can be managed using either the firmware or the Bosch RAIDWatch web-based GUI. The firmware can be accessed by using either the LCD panel (see *Figure 2.2*) located at the front of the subsystem or a terminal emulation program installed on an external computer and connected to the COM1 on the controller module's rear panel (see *Figure 2.2*) with the provided serial cable.

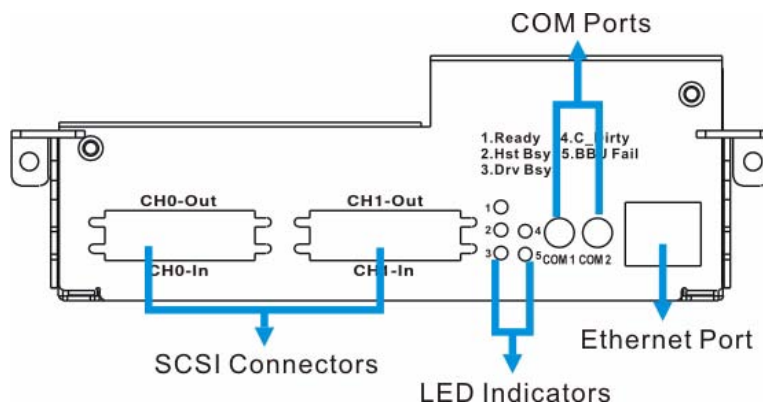

Fig. 2.2 Controller Module Rear Panel

If web-based management is desired, connecting the subsystem to the world wide web through the Ethernet port on the controller module's rear panel, (See *Figure 2.2*) allows you to manage the RAID subsystem by Bosch RAIDWatch management software.

2.3

Best Practices

2.3.1

Avoiding Points of Failure

To achieve maximum uptime when connecting a RAID subsystem into a storage environment, it is imperative that points-of-failure are avoided. The best way to avoid them is through the use of redundant components. As stated above, the cooling modules and PSU modules on the subsystem are fully redundant. Using dual-redundant data paths will further minimize the possibility of system downtime.

2.3.2

Dual-Redundant Data Paths

When connecting the RAID subsystem to a server, dual-redundant data paths are recommended. If one (1) data path fails, a second data path can be used to transmit data. Dual-redundant data paths are supported by both the host and drive channels.

2.3.3

ID Mapping

Host ID mapping is flexible, in the sense that the same array can be associated with different host ID/LUNs, allowing the host clustering configurations. Drives on different channels can then be grouped into an array, and the array has its unique volume size, stripe size, and optimization mode. Arrays of different RAID levels can be striped together into logical volumes, making management of huge volume size an easier task.

2.4 Enclosure Chassis

2.4.1 Chassis Overview

The RAID storage subsystem chassis is an enhanced 3U metal chassis divided into front and rear sections, which are respectively accessed through front (see *Figure 2.4*) and rear (see *Figure 2.6*) panels. Pre-drilled mounting holes in the sides of the 3U RAID subsystem enclosure allow you to attach separately purchased slide rails so that you can install the enclosure into a rack or cabinet.



NOTICE!

Components accessed through the front panel are referred to as “Front Panel Components” and components accessed through the rear panel are referred to as “Rear Panel Components.”

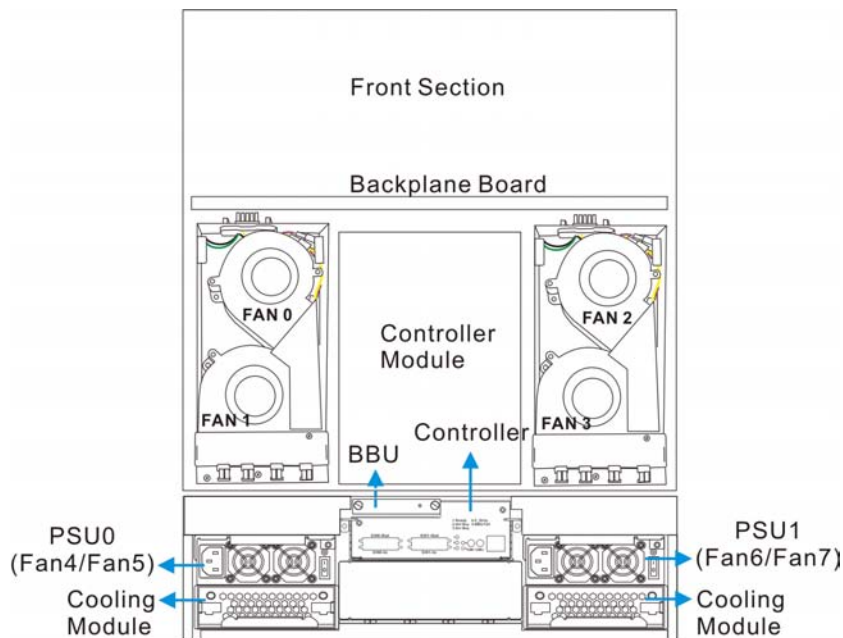

Fig. 2.3 RAID subsystem Overview

2.4.2 Physical Dimensions

The RAID subsystem comes in an enhanced 3U chassis with the following dimensions:

- With handles: 482.6mm x 131mm x 504.3mm (width x height x depth)
- Without handles: 445mm x 130mm x 488.2mm (width x height x depth)

2.4.3 Front Panel Overview

The front section of the subsystem features a 4 x 4 layout for sixteen (16) 3.5-inch drives. The two (2) handles on the front of the subsystem enable you to easily insert/extract the chassis into/from a rack or cabinet. The LCD panel on the left handle provides an easy way for you to monitor and configure your subsystem.

The front panel of the RAID subsystem described in this manual is shown in *Figure 2.4*. A description of each front panel component is given below:

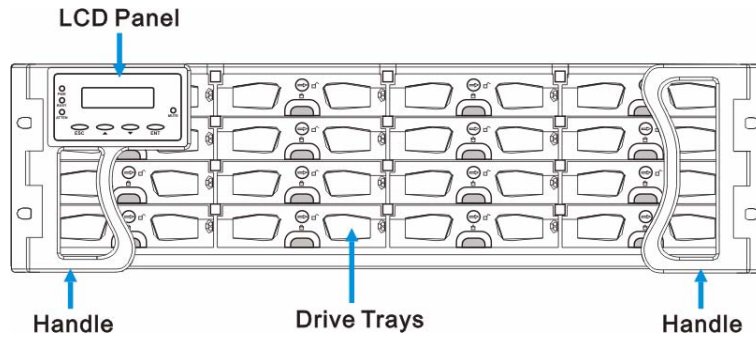

Fig. 2.4 RAID subsystem Front View

The front panel shown in *Figure 2.4* accommodates the following components:

- Drive bays with drive tray canisters: The drive bays house the hard drives.
- Right handle and left handle with LCD panel: The subsystem has right and left handles for easier rackmounting and handling. The LCD panel shows system information and can be used to configure and monitor the RAID subsystem. (Please refer to *Section 2.5.1 LCD Panel*)

2.4.4 Hard Drive Numbering

The front panel of the RAID subsystem enclosure houses sixteen (16) hard drives in a 4x4 configuration as shown in *Figure 2.5*. When viewed from the front, the drive bays (slots) are numbered 1 to 16 from left to right, from top to bottom.

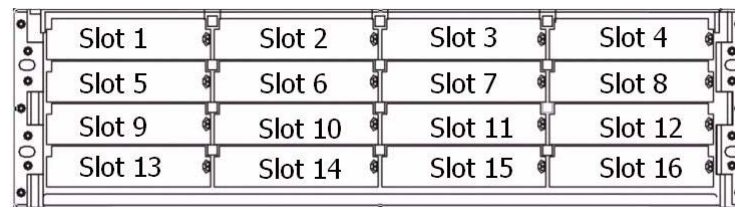

Fig. 2.5 Hard Drive Numbering

2.4.5 Rear Panel Overview

The rear section of RAID subsystem is accessed through the rear panel and is reserved for a single RAID controller module, one (1) BBU, two (2) power supply units (PSUs) and two (2) cooling modules.

The rear panel of the RAID subsystem described in this manual is shown in *Figure 2.6*. A description of each rear panel component is given below:

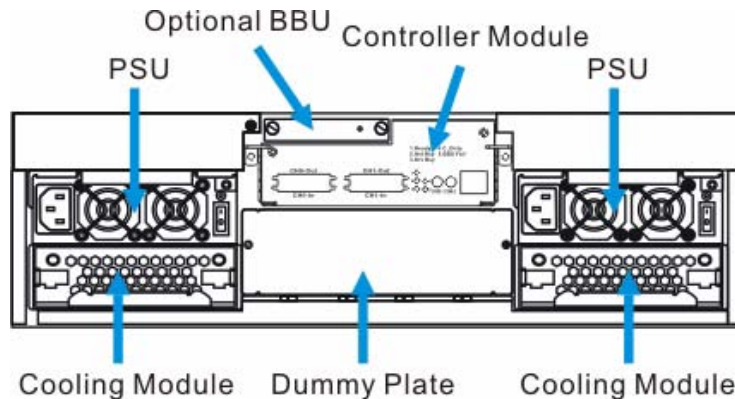

Fig. 2.6 RAID subsystem Rear View

The rear panel shown in *Figure 2.6* accommodates the following components:

- RAID controller module: A controller board and a DDR RAM DIMM module are housed in the controller module to provide the system RAID functionalities. (See *Section 2.5.3 The RAID Controller Module*)
- BBU: A BBU sustains cache memory during a power shortage to prevent data loss. (See *Section 2.5.6 Battery Backup Unit (BBU)*)
- PSUs: The hot-swappable PSUs provide power to the subsystem. A power switch is located on the right of each PSU to turn the system on and off. (See *Section 2.5.7 Power Supply Units*)
- Cooling modules: The redundant cooling modules ventilate the subsystem to reduce the temperature within the subsystem. (See *Section 2.5.8 Cooling Modules*)
- Dummy plate: This device is a single controller subsystem. The only controller module is installed in the upper controller bay. A dummy plate covers the lower controller bay at the rear of the subsystem.

2.4.6

Backplane Board

Internal backplane boards separate the front and rear sections of the RAID subsystem. The PCB board provide logic level signals and low voltage power paths. They contain no user-serviceable components.

2.5

Subsystem Components

The RAID subsystem houses many active components and most of them can be accessed through either the front or rear panel. The modular design of the active components facilitates their easy installation and removal. Hot-swap mechanisms are incorporated to eliminate power surges and signal glitches that might occur while removing or installing these modules.

2.5.1

LCD Panel



Fig. 2.7 LCD Panel

The LCD panel shown in *Figure 2.7* consists of a 16x2-character LCD screen with push buttons and LED status indicators. The LCD front panel provides full access to all RAID configuration settings and monitoring functions. After powering up the subsystem, the initial screen will show the subsystem model name. A different name may be assigned for the system or different arrays. This will enable easier identification in a topology with numerous arrays.

2.5.2

Drive Trays

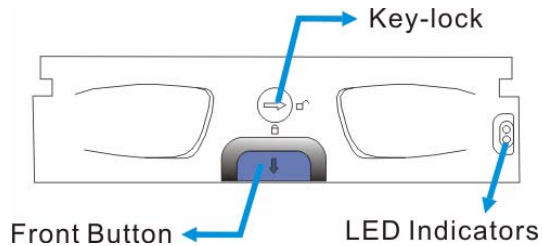

Fig. 2.8 Drive Tray Front View

The RAID subsystem comes with sixteen (16) drive trays (See *Figure 2.8*) designed to accommodate separately purchased standard 1-inch pitch, 3.5-inch disk drives. The drive bays are easily accessible from the front of the enclosure. Two (2) LEDs on the front of the tray indicate the drive status. A key-lock on each drive tray secures the hard drive in place, while an easily accessible button ensures fast and efficient drive hot-swapping.

CAUTION!

Be careful not to warp, twist, or contort the drive tray in any way (e.g., by dropping it or resting heavy objects on it). The drive tray has been customized to fit into the drive bays in the RAID subsystem. If the drive bay superstructure is deformed or altered, the drive trays may not fit into the drive bay.

2.5.3

The RAID Controller Module

The RAID controller module contains a main circuit board, a preinstalled 256MB capacity or above DDR RAM DIMM module and the controller module interfaces. The controller module contains no user-serviceable components. Except when installing/upgrading the cache memory inside, the controller module should never be removed or opened.

CAUTION!

Although the RAID controller can be removed, the only time you should touch the controller itself is to install the memory modules. The RAID controller is built of sensitive components and unnecessary tampering can damage the controller.

The heart of the RAID controller subsystem is the 320MB per second SCSI-to-SATA controller board. The controller comes with two (2) pre-set SCSI-320 host channels, CH0 and CH1. The subsystem connects to the host through a VHDCI SCSI input connector, while the output connector is ready to connect external devices. (See *Figure 2.9*)

The docking connector at the rear of the controller board is used to connect the controller module to the backplane board. A DDR RAM DIMM socket is strategically placed in an easily accessible location on the controller board for easy insertion of the DDR RAM DIMM module.

2.5.4

Controller Module Interfaces

All external interfaces that connect to external devices are located on the controller module rear panel shown in *Figure 2.9*. The interfaces are listed below.

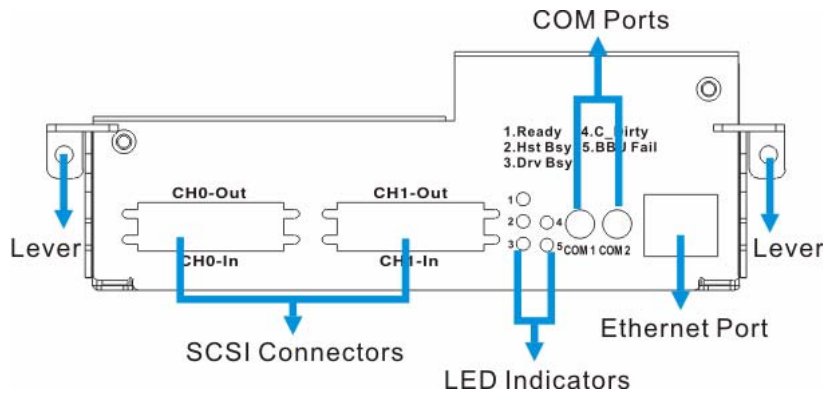

Fig. 2.9 Controller Module Interfaces

- Host Ports: Two (2) SCSI-320 host channels (CH0 and CH1 in *Figure 2.9*) connect the subsystem to the host through two (2) dual-stacked VHDCI SCSI connectors.
- Ethernet Ports: A single 10/100BaseT Ethernet port (located next to COM2) is used for remote management through the network.
- COM ports: The controller module comes with two (2) COM ports. One port is used to access the controller-embedded configuration utility through the network, and the other connects to a UPS connection. Please refer to *Section 7 Appendix A: Uninterruptible Power Supply* for the instructions on connecting a UPS.
- Levers: Two (2) levers located in the sides of the controller board rear panel provide easy controller module installation and secure the controller module in place.

2.5.5

DIMM Module

The controller module comes with a pre-installed 256MB capacity or above DDR RAM DIMM module and can support capacities up to 1GB. The DIMM module is placed in an easily accessed location on the controller board. However, when the DIMM module is being changed, the controller module must be removed from the subsystem chassis.

2.5.6

Battery Backup Unit (BBU)

The Li-ION battery backup unit (BBU) (see *Figure 2.11*) sustains cache memory after a power failure. It is installed on the upper left side of the controller module in the rear subsystem chassis.

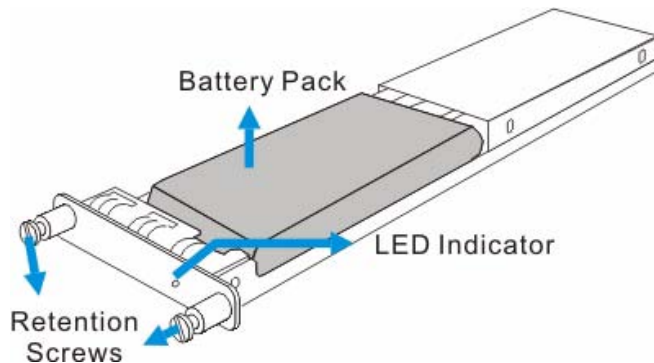

Fig. 2.10 BBU Module

In accordance with international transportation regulations, the BBU is only charged to between 35% and 45% of its total capacity when shipped. Therefore, after powering on the subsystem (see *Section 5.4 Power On*) the BBU must be charged to its full capacity. It normally requires approximately twelve (12) hours for the battery to be fully charged. If the battery is not fully charged after twelve (12) hours, there is a problem with the BBU and you should contact your subsystem vendor immediately. While the battery is being charged, the LED on the

BBU rear panel and the fifth LED on the rear panel of the controller module will flash slowly. (See *Section 4.2.6 BBU Module LED* for details on the LED indicators.) You can check the status of the battery's charge via Bosch RAIDWatch or the firmware.

2.5.7

Power Supply Units

The RAID subsystem is equipped with two (2) redundant, hot-swappable, 460W PSUs, which are located at the rear of the enclosure. (See *Figure 2.6*) The PSU is permanently mounted into a 2U (dual-level) bracket especially designed to house both the PSU and a cooling module, which is mounted in the lower part of the 2U bracket. Hot-swapping the PSU requires the removal of the cooling module.

As shown in *Figure 2.11*, each PSU comes with a single power socket for power cord plug-in, and a power switch on the right to turn the subsystem on and off. Two (2) embedded cooling fans provide sufficient airflow to keep the PSU cool. A single LED indicates the PSU status. When any power supply failure occurs, such as over-voltage or fan failure, the LED shines red. A handle at the back of the PSU has been especially designed to enable you to remove the PSU from the subsystem while the subsystem is online. This should only be done if the PSU has failed and needs to be replaced.

A retention screw at the top of the PSU module secures the PSU to the enclosure. To remove the PSU, the retention screw must be removed first. When installing a new PSU module, make sure that the retention screw has been firmly secured.

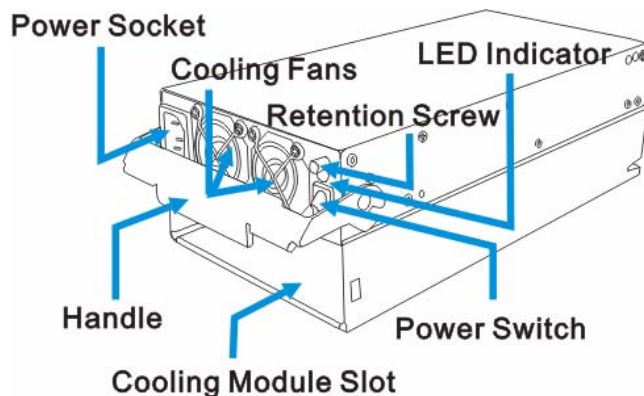

Fig. 2.11 PSU Module

For the PSU specifications, please refer to *Section 7 Appendix: Specifications*.

2.5.8

Cooling Modules

The RAID subsystem is equipped with two (2) 1U, dual-fan, redundant, hot-swappable cooling modules. They are installed in the cooling module slots located in the lower section of the PSU modules (see *Figure 2.12*.) The two (2) 9.7cm fans housed in each cooling module provide two (2) fan speeds. When the subsystem is running in normal ambient temperature, the fans operate at the lower speed. When the temperature reaches the temperature threshold, the fans automatically change to high speed to generate more cooling air from the front to the rear of the subsystem to extract the heat generated by the hard drives.

Cooling module specifications are listed in *Section 7 Appendix: Specifications*.

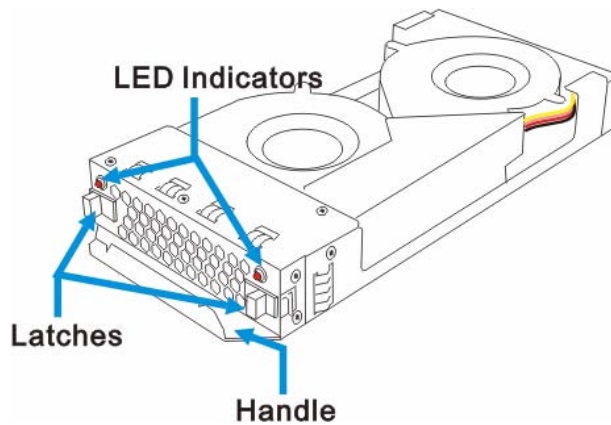

Fig. 2.12 Cooling Module

2.6 Subsystem Monitoring

The RAID subsystem comes with a number of different monitoring methods that provide you with continual updates on the status of the system and individual components. The following monitoring features are included in the subsystem.

2.6.1 I²C bus

The following elements are interfaced to the RAID controller over a non-user-serviceable I²C bus:

- PSU modules
- Cooling modules
- Temperature sensors (for the temperature of the backplane board and controller board)

2.6.2 LED Indicators

The following active components come with LEDs to indicate the status of the individual component:

- RAID controller (5 LEDs)
- LCD panel (3 LEDs)
- BBU (2 LEDs)
- Cooling modules (2 LEDs)
- PSU modules (1 LED)
- Drive trays (2 LEDs)

2.6.3 Firmware (FW) and Bosch RAIDWatch GUI

Firmware: The firmware is pre-installed software used to configure the subsystem. The latest firmware functionalities include Task Scheduler, Intelligent Drive Handling, and Media Scan. Media Scan handles low quality drives in both the degraded mode and during the rebuild process. Maintenance tasks will then be performed on an entire array or specific hard drives. Various options are user-configurable such as priority, start time, and execution internals.

Bosch RAIDWatch: Bosch RAIDWatch is a premier web-based graphics user interface (GUI) that can be installed on a remote computer and accessed via the web. The manager communicates with the array via the connection of the existing host interface or Ethernet link to the array's LAN port.

2.6.4 Audible Alarms

The RAID subsystem comes with audible alarms that are triggered when certain active components fail or when certain (controller or subsystem) thresholds are exceeded. Whenever you

hear an audible alarm from the RAID subsystem, it is imperative that you determine the cause and rectify the problem immediately.

Event notification messages indicate the completion or status of array configuration tasks and are always accompanied by two (2) or three (3) successive and prolonged beeps.

CAUTION!

Failing to respond when an audible alarm is heard can lead to permanent damage of the RAID subsystem. When an audible alarm is heard, rectify the problem as soon as possible.

2.7 Hot-swappable Components

2.7.1 Hot-swap Capabilities

The RAID subsystem comes with a number of hot-swappable components. A hot-swap component is one that can be exchanged while the subsystem is still online without affecting the operational integrity of the subsystem. These components should only be removed from the subsystem when they are being replaced. At no other time should these components be removed from the subsystem.

2.7.2 Components

The following components are hot-swappable:

- Power supply units (PSUs)
- Cooling modules
- BBU
- Hard drives

2.7.3 Normalized Airflow

Proper subsystem cooling is referred to as “normalized” airflow. Normalized airflow ensures the sufficient cooling of the subsystem and is only attained when all components are properly installed. Therefore, a failed component should only be hot-swapped when a replacement is available. If a failed component is removed but not replaced, permanent damage to the subsystem can result.

3 Hardware Installation

3.1 Introduction

This chapter gives detailed instructions on how to install the subsystem. When installing the subsystem, it is necessary to install the controller module, hard drives, and drive trays. Installation into a rack or cabinet should occur before the hard drives or drive trays are installed into the subsystem. Please confirm that you received all of the components listed on the Unpacking List that came with the subsystem before proceeding with the installation process.

CAUTION!

Please note that the installation instructions described in this manual should be carefully followed to prevent any difficulties and damages to your system.

3.2 Installation Prerequisites

1. Static-free installation environment: The RAID subsystem must be installed in a static-free environment to minimize the possibility of electrostatic discharge (ESD) damage. (See *Section 3.3.2 Static-free Installation*)
2. Component check: Before installing the RAID subsystem, you should first check to see that you have received all the required components. (See *Section 3.5 Unpacking the Subsystem*) If any items appear damaged, contact your vendor for a replacement.
3. Hard drives: Up to sixteen (16) SATA-I or SATA-II hard drives must be purchased separately prior to the RAID subsystem installation.
4. Cabling: The RAID subsystem requires an external VHDCI to VHDCI SCSI round cable to connect the subsystem to a host computer. Please see *Section 5 Subsystem Connection and Operation* for sample topologies and configuration options.
5. Memory module: If you wish to change the pre-installed memory module, a separately purchased module must be installed. (See *Section 6.3 DIMM Module Replacement*)
6. Rack installation: The enclosure chassis can be installed into rack cabinet using separately purchased mounting rails, rear-attached brackets, or Bosch's slide rails. (See *Section 3.6 Rack/Cabinet Installation*)

3.3 Safety Precautions

3.3.1 Precautions and Instructions

1. Be sure the correct power range (100-120 or 200-230VAC) is supplied by your rack cabinet or power outlet.
2. Thermal notice: All drive trays (even if they do not contain a hard drive) must be installed into the enclosure. Leaving a drive bay or module slot open will greatly affect the airflow efficiency within the enclosure, and will consequently lead to system overheating. Keep a faulty module in place until you have a replacement unit and you are ready to replace it.
3. An enclosure without disk drives can weigh over 24 kilograms. Two (2) people are required to install or relocate the subsystem. Drives should be removed from the enclosure before moving the subsystem.
4. Airflow considerations: The subsystem requires an airflow clearance especially on the front and rear. For proper ventilation, a minimum of 2.5cm is required between the front of the enclosure and rack cover; a minimum of 5cm is required between the enclosure and end of the rack.
5. Handle the system modules by the retention screws, eject levers, or the module's metal frame/face plate only. Avoid touching the PCB boards and connector pins.

6. None of the covers or replaceable modules should be removed in order to maintain compliance with safety, emission, or thermal requirements.
7. Always secure every enclosure module by its retaining screws or make sure it is held in place by its latches.
8. Always make sure the subsystem has a safe electrical earth connection via power cords or chassis ground by the rack cabinet.
9. Be sure that the rack cabinet in which the subsystem chassis is to be installed provides sufficient ventilation channels and airflow circulation around the subsystem.
10. Provide a soft, clean surface to place your enclosure on before working on it. Servicing the enclosure on a rough surface may damage the finish of the chassis.
11. If it is necessary to transport the subsystem, repackage all drives and replaceable modules separately.

3.3.2

Static-free Installation

Static electricity can damage the system's electronic components. To prevent ESD damage to any of the components, follow these precautions before touching or handling them:

- Discharge the static electricity accumulated in your body by wearing an anti-static wristband.
- Avoid carpets, plastic, vinyl, and Styrofoam in your work area.
- Handle all components by holding their edges or metal frames. Avoid touching the exposed circuitry on PCB boards and connector pins.

3.4

General Installation Procedure

Following all the instructions provided below can save subsystem installation time. Detailed, illustrated instructions for each component are given in the following sections.

CAUTION!

To ensure that your system is correctly installed, please follow the steps outlined below. If you follow these steps, installation will be fast and efficient. If you do not follow these steps, you may accidentally install the hardware incorrectly.

1. **Unpack:** Unpack the subsystem and confirm that all the components on the packing list have been included. (See *Section 3.5 Unpacking the Subsystem*)
2. **Rack/Cabinet installation:** If the subsystem is going to be installed in a rack or cabinet, it should be installed prior to installing the hard drives. Installing the subsystem into a rack or cabinet requires at least two (2) people. (See *Section 3.6 Rack/Cabinet Installation*)
3. **Install drive trays:** After the hard drives have been installed into the drive trays, the drive trays must be installed into the enclosure itself. (See *Section 3.7 Drive Tray Installation*)
4. **Cable connection:** Use the power cables to connect the subsystem to the main power source. Use the SCSI cable to connect a host port to the host computer or an external device.
5. **Power up:** Once the components have been properly installed and all cables are properly connected, you can power up the subsystem and configure the RAID array. (See *Section 5.4 Power On*)

3.4.1

Installation Procedure Flowchart

Table 3.1 shows a flowchart of the installation procedure. As you complete each step, check the "Done" box on the right. Please use this flowchart in conjunction with the instructions that follow.

Step	Installation Procedure	Done	
1	Unpack	<input type="checkbox"/>	See <i>Section 3.5 Unpacking the Subsystem</i>
3	Rack/Cabinet Installation	<input type="checkbox"/>	See <i>Section 3.6 Rack/Cabinet Installation</i>
5	Drive Tray Installation	<input type="checkbox"/>	See <i>Section 3.7 Drive Tray Installation</i>
6	Cable Connection	<input type="checkbox"/>	
7	Power On	<input type="checkbox"/>	See <i>Section 5.4 Power On</i>

Table 3.1 Installation Procedure Flowchart

3.5 Unpacking the Subsystem

Use the Unpacking Checklist in your package to verify package contents. Carefully check the items contained in each box before proceeding with installation.



NOTICE!

A detailed packing list can be found in your product shipping package or product CD.

3.6 Rack/Cabinet Installation

The RAID subsystem has been designed to fit into a standard cabinet or rack. Two (2) slide rails are available for installing the subsystem into a rack or cabinet. Please contact your system vendor for further details. The subsystem should be installed in the rack or cabinet before the hard drives and the drive trays are installed. If the drive trays with the associated hard drives are installed, the subsystem will be too heavy to mount into a rack or cabinet. When installing the subsystem into a rack or cabinet it is advisable that three people assist in the mounting process.

To install the subsystem into a rack or cabinet please refer to the installation instructions that came with the slide rails.

3.7 Drive Tray Installation

Once the hard drives have been installed in the drive trays, the drive trays can be installed into the RAID subsystem.

CAUTION!

All drive trays must be installed into the enclosure even if they do not contain a hard drive. If the trays are not installed into the enclosure, the ventilation required for cooling will not be normalized and the subsystem will overheat.

1. Make sure the key-lock is in the unlocked position, i.e., the groove on its face is in a horizontal orientation. If the groove is in a vertical position, as shown in *Figure 3.1*, then the key-lock is locked and the front flap on the drive tray cannot be opened.

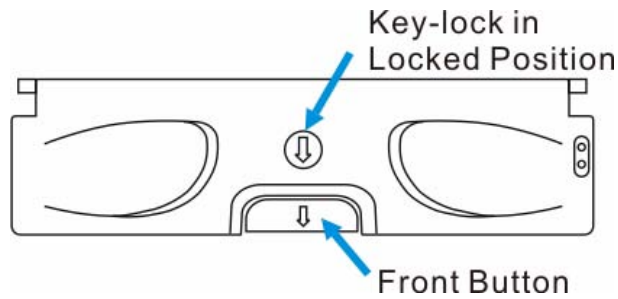

Fig. 3.1 Front View of an Individual Drive Tray

2. Open the front flap on the drive tray. (See *Figure 3.2*) Push the button on the front of the drive tray. The front flap will open in an upward direction.

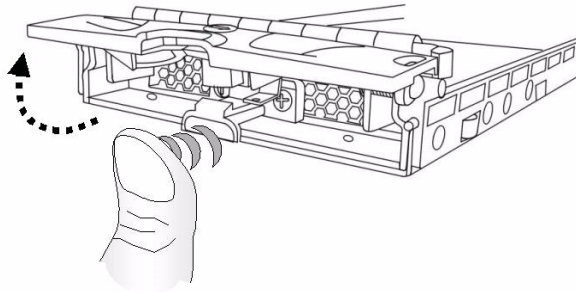

Fig. 3.2 Drive Tray Front Flap

3. Align the drive tray with the slot in which you wish to insert it. Make sure that it is resting on the rails inside the enclosure. Once the drive tray is lined up with the slot, gently slide it in. This should be done smoothly and gently. (See *Figure 3.3*)

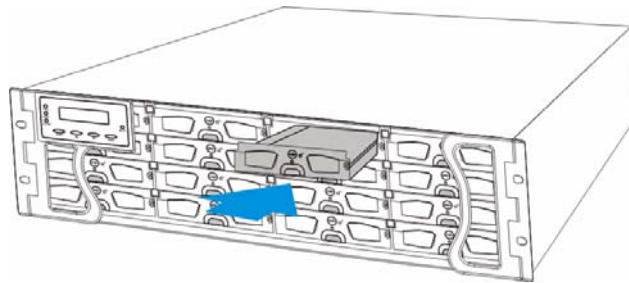

Fig. 3.3 Installing a Drive Tray

4. Close the front flap on the drive tray. Make sure the front flap is closed properly to ensure that the SATA connector at the back of the drive tray is firmly connected to the corresponding connector on the mid-plane board. If the front flap is not closed properly, the connection between the hard drive and the subsystem will not be secure.
5. Lock the flap into place by turning the key-lock until the groove on its face is pointing down (vertical orientation). (See *Figure 3.4*)

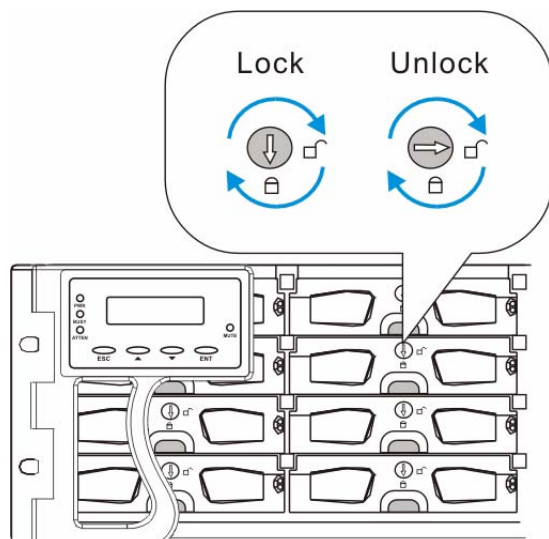

Fig. 3.4 Drive Tray Key-lock Rotation

6. Once the drive tray is inserted, the RAID controller will recognize the drive and scan it in automatically.

4 Subsystem Monitoring

4.1 Subsystem Monitoring Overview

The RAID subsystem is equipped with a variety of self-monitoring features that help to keep subsystem managers informed of the subsystem operational status. These monitoring features provide vital feedback to help you maintain the operational integrity of the subsystem. Prompt response to warnings and subsystem component failure notifications will improve the overall operation of the subsystem and help ensure the longevity of the RAID subsystem.

Self-monitoring features include:

- **Firmware (FW):** The controllers in the RAID subsystem come with pre-installed FW, which can be accessed using either the LCD panel or a PC Hyper Terminal. The RAID subsystem can be connected to a PC hyper-terminal through the COM ports. Device status information can be obtained from the FW.
- **Bosch RAIDWatch:** Bosch RAIDWatch is a fully integrated, Java-based, Graphics User Interface (GUI) that came with the subsystem and can be used to monitor and maintain the subsystem and the RAID controllers using your web browsers. The LAN port at the back of each controller module enables you to use an Ethernet cable to connect to the subsystem.

The Bosch RAIDWatch Panel View can be customized to show a direct representation of the subsystem in the content panel of the Bosch RAIDWatch screen. Panel View allows you to quickly determine the operational status of critical components.

- **Configuration Client:** The Configuration Client is a powerful module that runs as a background Disk and Executive Monitor (DAEMON) independent from Bosch RAIDWatch that can be installed redundantly on different hosts. It is used for event notification via email, fax, LAN broadcast, SNMP traps, MSN Messenger, ICQ, SMS short messages, and the configuration utility screen. The Configuration Client helps prevent blind time and keeps you constantly informed as to the status of the storage management subsystem.
- **LEDs:** Device-status-indicating LEDs are located on all active components. These LEDs inform you of the integrity of a given component or a given link. You should become familiar with the different LEDs that are present on the subsystem and be aware of their functions.
- **Audible alarm:** An audible alarm is present on the subsystem controller board and will be triggered if any of a number of threatening events occur. These events usually jeopardize the functional and operational integrity of the controller board and must be heeded at all times. Events such as a breaching of the temperature threshold will trigger the alarm. If a subsystem manager is present, the manager should use either the LCD panel or the PC hyper-terminal to determine the cause of the alarm and take the appropriate corrective measures. (See *Section 4.3 Audible Alarm*)
- **I²C:** The I²C bus monitors the operational integrity of the PSUs, cooling modules, and RAID controller board temperature.

Subsystem monitoring is a necessary part of subsystem management. If failure events or other disruptive events are detected and reported, the subsystem managers must take the appropriate action to rectify the problem. Failure to act in a properly specified manner to a system event (like overheating) can cause severe and permanent damage to the subsystem.

4.2 Status Indicating LEDs

4.2.1 Brief Overview of the LEDs

The following devices all come with LEDs that inform subsystem managers about the operational status of the component on which they are mounted. The RAID subsystem has a total of 49 status-indicating LEDs distributed over the active components in the following ways:

Component	LEDs per module	Total LEDs	Definition
LCD Panel	3	3	See <i>Section 4.2.2 LCD Panel</i>
Drive Trays	2	32	See <i>Section 4.2.3 Drive Tray LEDs</i>
Controller Modules	5	5	See <i>Section 4.2.4 Controller Module LEDs</i>
LAN port	2	2	See <i>Section 4.2.5 LAN Port LEDs</i>
BBU Module (if BBU is applied)	1	1	See <i>Section 4.2.6 BBU Module LED</i>
PSU Module	1	2	See <i>Section 4.2.7 PSU LEDs</i>
Cooling Module	2	4	See <i>Section 4.2.8 Cooling Module LEDs</i>

Table 4.1 LED Distribution

LED definitions are given in the following sections.

4.2.2 LCD Panel

The LCD panel shown in *Figure 4.1* consists of five (5) buttons, three (3) LEDs, and a 16x2-character LCD screen that indicates subsystem status. Press “ENT” button for two (2) seconds on the initial screen to enter the main menu. Press the “ESC” button to clear current event.

Press the ENT button for two (2) seconds on the initial screen to enter the Main Menu. Press the ESC button to clear the current event.

Press the UP and DOWN arrow keys to select viewing items. In the last item, “View and Edit Event Logs,” the most recent event is displayed first.

For dual RAID controllers, the LCD shows the status of the primary controller. Press the UP and DOWN arrow keys for more than one (1) second to display the status of the secondary controller.

The MUTE button can be used to stop the alarm until the next controller event occurs.

Three (3) LEDs monitor the status of the system. The definitions of these LEDs are given below.

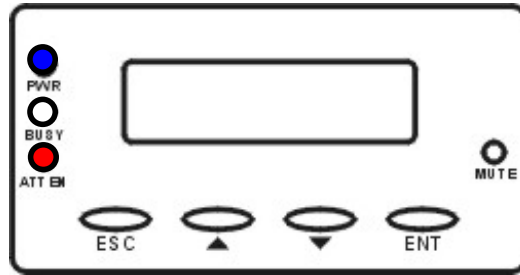

Fig. 4.1 LCD Panel

Name	Color	Status
PWR (Power)	Blue	ON indicates that power is being supplied to the subsystem. OFF indicates that no power is being supplied to the subsystem.
BUSY	White	FLASHING indicates that there is activity on the host/drive channels. OFF indicates that there is no activity on the host/drive channels.
ATTEN (Attention)	Red	ON indicates that a component failure/status event has occurred. OFF indicates that the subsystem and all its components are operating correctly.

Table 4.2 LCD Panel LED Definitions



NOTICE!

During the power up process, the LCD panel ATTN LED will be turned on. If the subsystem boots up correctly, then the ATTN LED will be turned off after the boot-up procedure is complete.

4.2.3

Drive Tray LEDs

Two (2) LED indicators are located on the right side of each drive tray, See *Figure 4.2*. Refer to *Figure 4.3* for the LED definitions. When notified by a drive failure message, you should check the drive tray indicators to find the correct location of the failed drive. Replacing the wrong drive can fatally fail a logical array.

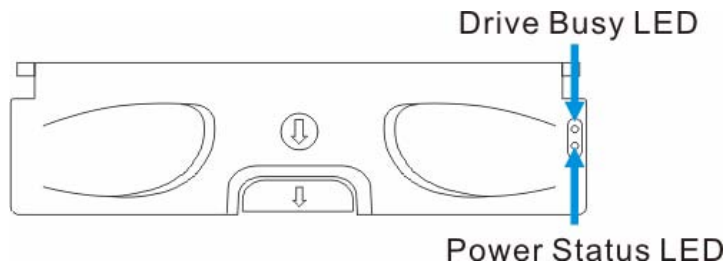

Fig. 4.2 Drive Tray LEDs

Name	Color	Status
Drive Busy	Blue	FLASHING indicates data is being written to or read from the drive. The drive is busy. OFF indicates that there is no activity on the drive.
Power Status	Green/ Red	GREEN indicates that a drive is installed in the drive tray RED indicates that there is a drive failure.

Table 4.3 Drive Tray LED Definitions

4.2.4

Controller Module LEDs

The rear panel of the controller module is shown in *Figure 4.3*. The LEDs on the controller's faceplate that can be accessed from the rear of the enclosure are numbered from 1 to 5. The definitions are shown in *Table 4.4*.

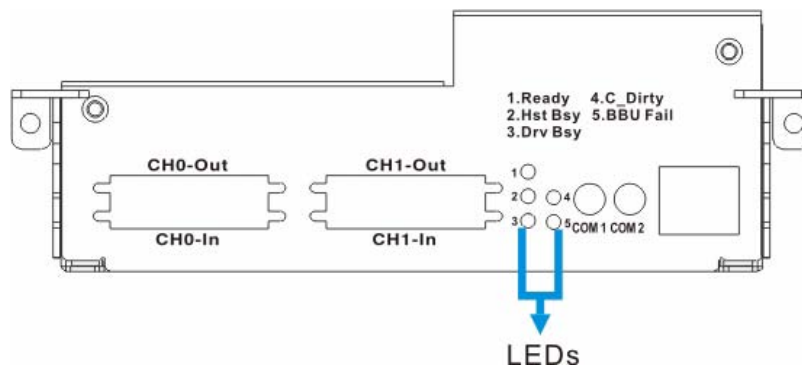

Fig. 4.3 LEDs on the Controller Module

LED	Name	Color	Status
1	Ready	Green	FLASHING indicates controller initialization is taking place. ON indicates the controller is active and operating properly. OFF indicates the controller is not ready for operation.
2	Hst Bsy (Host Busy)	Green	FLASHING indicates there is activity on the host ports. OFF indicates there is no activity on the host ports.

Table 4.4 Controller Module LED Definitions

3	Drv Bsy (Drive Busy)	Green	FLASHING indicates there is activity on the drive ports. OFF indicates there is no activity on the drive ports.
4	C_Dirty (Cache Dirty)	Amber	ON indicates that the cache memory is dirty or is being held up via the BBU during a system power loss.
5	BBU Fail	Amber	ON indicates the BBU cannot sustain the cache memory. This maybe caused by a missing BBU. OFF indicates the BBU is functioning normally and is able to sustain the cache memory. FLASHING indicates the BBU is charging. NOTE: This LED is only functional when a BBU is installed in the subsystem.

Table 4.4 Controller Module LED Definitions (Cont.)

4.2.5

LAN Port LEDs

A shielded Ethernet cable must be used to connect the RJ-45 Ethernet port to a hub on a network after you assign a permanent IP to the RAID subsystem. This enables you to manage your subsystem via the web. Two (2) LEDs located on the Ethernet port indicate the Ethernet connection status. See *Figure 4.4* for the locations of the two (2) LED indicators. Refer to *Table 4.5* for the LED definitions.

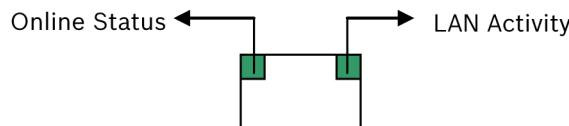

Fig. 4.4 LAN Indicators

Name	Color	Status
Online Status	Green	ON indicates currently connected to a LAN
LAN Activity	Green	BLINKING indicates active transmission

Table 4.5 LAN Port LEDs Definitions

4.2.6

BBU Module LED

The BBU has an LED on the right side of the rear panel. (See *Figure 4.5*) The function is the same as the fifth LED on the controller module. The LED is off when the BBU is functioning normally and is able to sustain the cache memory. The LED flashes to indicate the BBU is charging. If the LED is illuminating amber, please re-charge the BBU or contact your system vendor to verify the problem.



Fig. 4.5 BBU Module LED

4.2.7

PSU LEDs

Each PSU comes with a single LED at the back (see *Figure 4.6*), located just above the power switch that turns on the subsystem. This LED indicates the operational status of the PSU module. Please refer to the PSU LED definitions shown in *Table 4.6*.

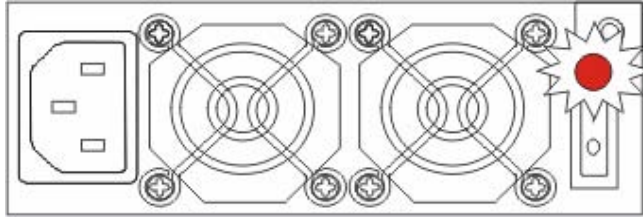

Fig. 4.6 PSU Module LED

Color	Status
FLASHING Green	The power supply has not been turned on. The PSU module LED will blink when the subsystem is connected to a power source but not yet turned on.
Static Green	The PSU is operating normally and experiencing no problem.
Static Red	The PSU has failed and is unable to provide power to the subsystem.
OFF	The PSU is not turned on. The PSU module LED will remain off even if the power cable has been plugged in but the power switch is not turned on.

Table 4.6 Module LED Definitions

4.2.8

Cooling Module LEDs

Each cooling module has two (2) red LEDs on the back. Each LED corresponds to a single fan in the cooling module. (See *Figure 4.7*) When the LED is on, it indicates the fan has failed. When the LED is off, it indicates the fan is functioning properly.

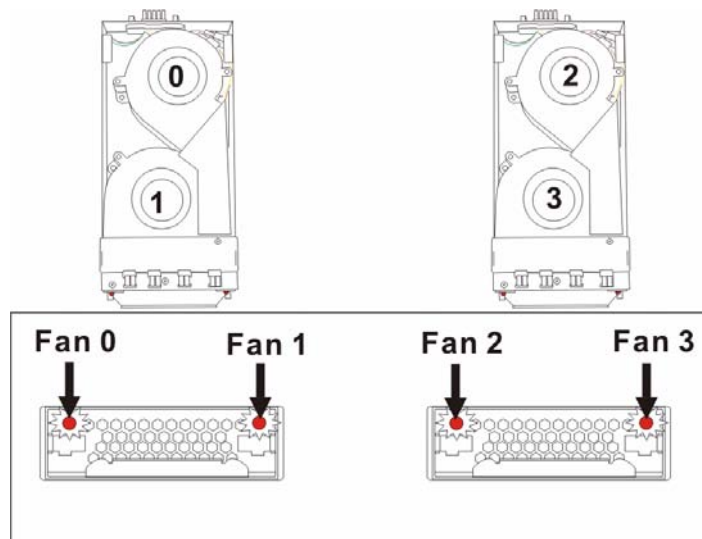

Fig. 4.7 Cooling Module LEDs and Cooling Fan Locations

The RAID subsystem has a novel approach to stabilizing the temperature within the subsystem: When the intelligent sensors on the backplane detect higher temperature, such as

high ambient temperature or the failure of any cooling or PSU module, the system will turn the cooling fans to high speed to extract more heat. Once the ambient temperature cools down to normal or the cooling or PSU modules have been replaced, the cooling fans will return to low speed.

4.3 Audible Alarm

Different controller environmental and operational parameters (like temperature, etc.) have been assigned a range of values between which they can fluctuate. If either the upper or lower thresholds are exceeded, an audible alarm will automatically be triggered. The alarm will also be triggered when an active component on the RAID subsystem fails. If the RAID subsystem manager is onsite and hears an alarm, the manager must read the error message on the LCD screen or PC terminal to determine what has triggered the alarm. After determining what has occurred, the RAID subsystem manager must take appropriate actions to rectify the problem.

CAUTION!

If an alarm is triggered it is necessary for you to determine the problem. If the audible alarm is ignored and the problem is not rectified, unexpected damages may occur.

4.3.1 Default Threshold Values

Table 4.7 shows the default threshold values for the RAID subsystem. If any of these values are surpassed, the alarm will sound:

	Upper Threshold	Lower Threshold
+3.3V	+3.6V	+2.9V
+5V	+5.5V	+4.5V
+12V	+13.2V	+10.8V
CPU Temperature	90°C	5°C
Board Temperature	80°C	5°C
Enclosure Ambient Temperature	40°C	0°C

Table 4.7 Default Threshold Values

The thresholds in Table 4.7 are default threshold values and may be changed.

4.3.2 Failed Devices

If any of the following devices fail, the audible alarm will be triggered:

- RAID controller module
- Cooling modules
- PSU modules
- BBU
- Hard drives

**NOTICE!**

When the temperature exceeds a preset threshold, the controller's charger circuits will stop charging. You will then receive a message that says "Thermal Shutdown/Enter Sleep Mode." When the temperature falls back within normal range, the battery will resume charging.

4.4**Monitoring**

Presence detection and the general working status of the cooling fan and other modules are monitored through an I²C serial bus. If any of these modules fail, you will be notified via the various methods described above.

5 Subsystem Connection and Operation

This chapter introduces sample topologies, daisy-chaining, and external device connections for the RAID subsystem and discusses both the power on and power off procedures.

5.1 SCSI Connection Overview

The RAID subsystem supports two (2) SCSI channels and two (2) dual-stacked SCSI connectors using SCSI-320 (also known as Ultra-320 SCSI), the latest iteration of the SCSI bus standard. SCSI-320 enables maximum data transfer rates of up to 320MB/second per channel between the host computers and the RAID subsystem. This is twice as fast as the Ultra-160 standard, allowing users to store data at the fastest SCSI speeds available.

5.1.1 SCSI Cables

One (1) SCSI cable is used for each RAID subsystem for host connection. A second SCSI cable is used to connect the second host channel. Use only high quality SCSI-320 cables from a reputable manufacturer. To ensure optimum performance, it is necessary to use proper, high quality, durable SCSI-320 cables. Failure to do so will result in downgraded performance.

5.1.2 SCSI Port on the Controller Rear Panel

The RAID subsystem is equipped with two (2) dual-stacked VHDCI SCSI connectors on the back of the enclosure for connecting the subsystem to a host computer and/or to daisy-chain other RAID subsystems. (See *Figure 5.1*) The connectors on the bottom of the controller rear panel are for data input and the connectors on the top are for data output.

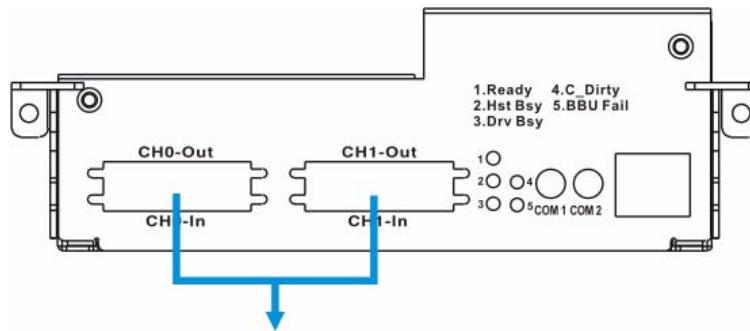

Dual-Stack VHDCI SCSI Connectors
Fig. 5.1 SCSI Connectors on the Controller Rear Panel

5.1.3 SCSI Termination

Correct SCSI termination procedures require that the last device on the SCSI bus be terminated. If the last device is not terminated or if devices other than the last are terminated, erratic SCSI bus behavior may occur.

An auto-detection, on-board terminator is built into the RAID subsystem. You do not need to install an external terminator when a subsystem acts as the last device in the daisy chain configuration. The on-board terminator default is enabled. If the subsystem is not the last device in the daisy chain configuration, the terminator will be automatically disabled. Although it is not recommended, if you prefer to disable the firmware setting for the on-board terminator using the LCD keypad panel on the subsystem, RS232C terminal session, or Bosch RAIDWatch management software, the auto-detection function is also disabled.

Typically, the host computer or host adapter (SCSI card inside the PC) is the first device and some are already terminated. When installing the RAID subsystem on a SCSI bus with other devices, be sure to observe the above rules regarding all devices on the SCSI bus. Consult your host computer and/or host adapter manual for additional information on correct termination procedures.

**NOTICE!**

It is recommended not to change the firmware default setting for the SCSI terminator so the auto-detection function can operate.

5.2 Host Connection Topology

There is no direct association between host ports and drive channels. Drives are associated with host port IDs as the logical configuration of drives, e.g., a logical drive. A logical drive can be composed of drives on different drive channels, and a logical drive can be associated with target IDs on different host ports.

Drive access contention (that may happen when two (2) host computers can access the same array) and data-path failover activities should be handled by a third-party software running on host computer(s).

RAID subsystem host channel SCSI connectors are connected to the servers via host bus adapters (HBAs) that have been installed on the host computer(s).

- Single server connection: If a single logical drive is mapped to a single server, a RAID management software should be installed in the server to execute RAID functionality.
- Multiple server connection: If a single logical drive is mapped to two (2) separate servers through dual-redundant data paths, separately purchased, third-party multipathing and clustering software must be installed on both servers. The clustering software will ensure that if one (1) server or the data path to a single server fails, the second server will continue to provide access to the data.

5.2.1

Single Host

In the example shown in *Figure 5.2*, one of the SCSI ports on the controller rear panel is connected to a single host computer.

	Single Server
Servers	One (1)
Subsystem	One (1) subsystem
RAID Controllers	One (1)
RAID Level	RAID 5
Disk Configuration	One (1) or more logical drives
Drives	Sixteen (16) drive channels
Host Bus Adapters	One (1) single-port SCSI
Data Path Connection	Dual-redundant data paths

Table 5.1 Configuration Overview for Single Server Connection

Host Computer

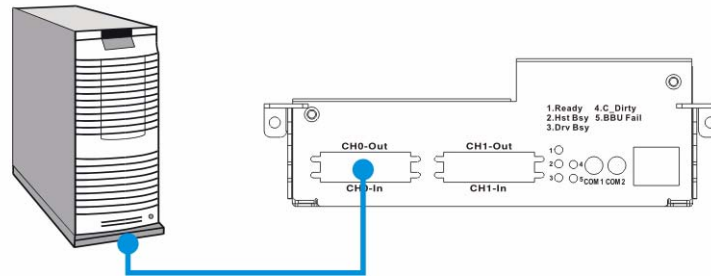

Fig. 5.2 Single Host Connection

When setting up the configurations, please follow these steps:

1. Power on the RAID subsystem.
2. Use the LCD panel or the terminal emulation program to access the firmware.
3. Create at least one (1) logical drive (LD0).
4. Map LD0 to CH0 or CH1.
5. Connect the server to CH0 or CH1 connectors.
6. Power on the servers.

5.2.2

Dual Hosts

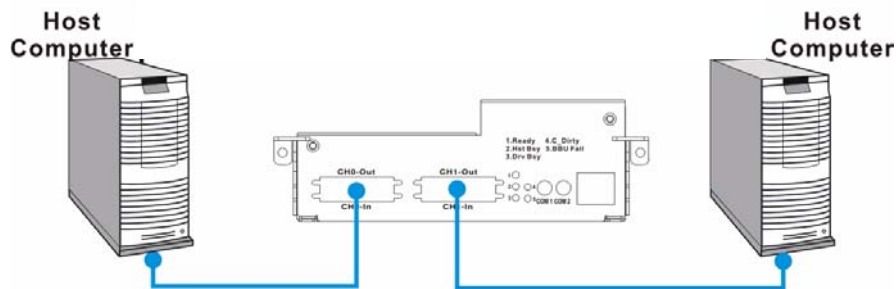

Fig. 5.3 Dual Host Connection

In the example shown in *Figure 5.3*, the two (2) SCSI ports on the RAID subsystem are connected to two (2) different host computers and an Ethernet cable connects both computers to each other. This configuration provides both path and host computer redundancy. If one of the host channels becomes disconnected for some reason, or the cable connecting one of the host ports to the host computer is damaged, the second path can transmit data from the subsystem to the host computer. Similarly, in the clustered hosts configuration, the same array can be accessed through different data paths and downtime will be minimized.



NOTICE!

To create dual redundant data paths on the host side, it is necessary to install third-party failover software on the host computer.

	Dual Server
Server	Two (2)
Subsystem	One (1) RAID subsystem
RAID Controllers	One (1)
RAID Level	RAID 5
Disk Configuration	Two (2) or more logical drives
Drives	Sixteen (16) drive channels
Host Bus Adapters	Two (2) single port SCSI on two (2) servers
Data Path Connection	Dual-redundant data paths

Table 5.2 Configuration Overview for Dual and Quad Server Connection

When setting up the configurations, please follow these steps:

1. Power on the RAID subsystem.
2. Use the LCD panel or the terminal emulation program to access the firmware.
3. Create at least one (1) or two (2) logical drives (LD0 and LD1).
4. Map all the LD to CH0, and CH1.
5. Connect the server1 to CH0/CH1 connector.
6. Connect the server2 to connector.
7. Power on the servers.

5.3

Daisy Chain

5.3.1

Daisy Chain Topology

The RAID subsystem offers the flexibility to daisy chain additional RAID subsystems to meet increasing storage needs. In a daisy chain topology, the RAID subsystem can be connected to each other. The IN ports on the first subsystem are both connected to separate SCSI-320 host computers. The OUT ports on the first subsystem are connected to the IN ports on the second subsystem. This process is repeated for the third subsystem.

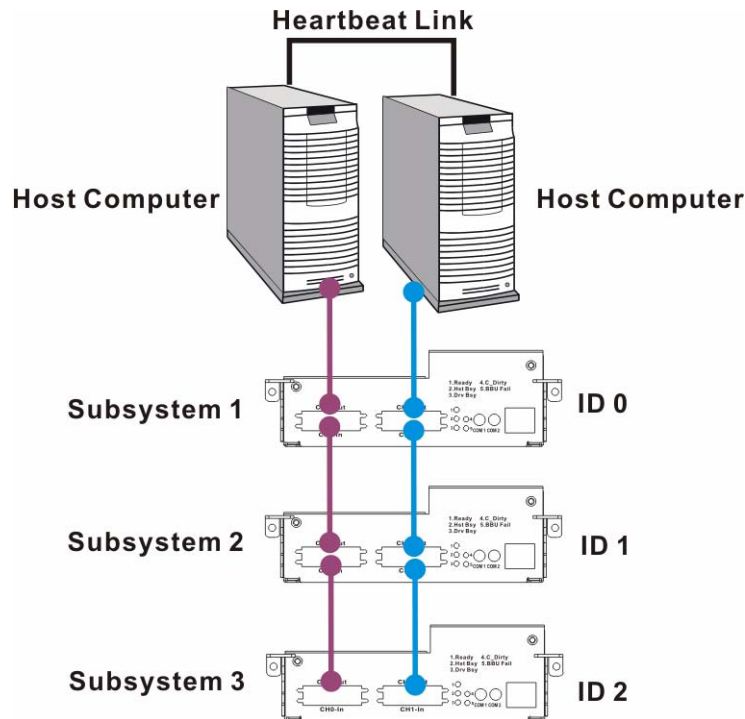

Fig. 5.4 Daisy Chain RAID Subsystems

5.3.2

Daisy Chain Procedures

1. Connect the RAID subsystem to the host computer. Use the VHDCI to VHDCI SCSI cable that was provided in the packaging box. Attach one end to the host computer and the other end to the SCSI IN port on the back of the RAID subsystem.
2. Daisy chain subsystems. If you wish to connect more than one subsystem, an extra VHDCI to VHDCI SCSI cable is required. Attach one end of the cable to the SCSI OUT port and the other end to the SCSI IN port in the next subsystem.
3. Assign chassis IDs. Each chassis must be assigned a unique chassis ID before being powered on. The chassis ID for the first RAID subsystem is 0. The chassis IDs for the subsystems connected to the first RAID subsystem are from 1 to 16. You can assign chassis IDs through the LCD panel on the subsystem, firmware, or Bosch RAIDWatch management software. (See Figure 5.4)
4. Create redundant host paths. If access to data is a critical requirement, redundant data paths to different LDs (logical drives) or logical volumes (LVs) can be created. To do this, logical units (LDs or LVs) are mapped to both host channels (CH0 and CH1 in Figure 5.4.) This will ensure that if one host computer fails, the second host computer will be able to access the logical units on that host computer.



NOTICE!

To create dual redundant data paths on the host side, it is necessary to install third-party failover software on the host computer.

5.4

Power On

Once all of the components have been installed in the RAID subsystem and the host channels have been connected to the host, the subsystem can be powered on.

5.4.1

Check List

Before powering on the RAID subsystem, please check the following:

- Memory module: Memory modules have been correctly installed on the controller boards.
- BBU: Ensure that the BBU has been installed correctly.
- Hard drives: Hard drives have been correctly installed in the drive trays.
- Drive trays: ALL the drive trays, whether or not they have a hard drive, have been installed into the subsystem.
- Cable connections: The host ports on the subsystem have been correctly connected to a host computer.
- Power cables: The power cables have been connected to the PSU modules on the subsystem and plugged into the main power source.
- Ambient temperature: All the subsystem components have been acclimated to the surrounding temperature.

5.4.2

Power On Procedure

When powering on the RAID subsystem, please follow these steps:

1. Power on the subsystems that are not connected directly to the host computer, if applied.

If you have daisy chained any RAID subsystem, power on those subsystems before powering on the first subsystem that is connected to your host computer(s).

2. Power on the RAID subsystem.

The first subsystem should be powered on before the host computers. To power on the subsystem please follow the description below.

Using the power cords provided in the package, connect both power sockets on the subsystem rear panel to the main power source.

Turn the two (2) power switches on. (See *Figure 5.5*) Each switch controls a single PSU, therefore make sure that both switches are turned on.

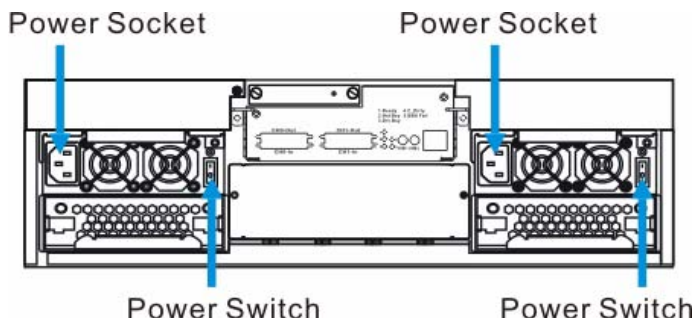

Fig. 5.5 Power Sockets and Power Switches

CAUTION!

Although the PSUs are redundant and a single PSU can provide sufficient power to the system, it is advisable to turn both the power switches on. If only one (1) PSU is operating and that PSU fails, the whole system will shut down.

3. Power on the host computers.

The host computers should be the last devices that are turned on. Please refer to the manual that came with your host computers to see their own power on procedures.

5.4.3

Power On Status Check

Once the RAID subsystem has been powered on, the status of the entire subsystem should be checked to ensure that everything is running smoothly and that there are no complications or malfunctions.

1. Controller module LEDs: The Controller Ready, Host Busy, and Drive Busy LEDs should all flash green.
2. Drive tray LEDs: The green LEDs for all the drive trays that contain hard drive should light up showing that there is power.
3. LCD panel LEDs: The blue LED on the LCD panel should illuminate, indicating that power is being supplied to the system.
4. Firmware and Bosch RAIDWatch: The overall status of the system may be checked using the pre-installed firmware or the Bosch RAIDWatch GUI.
5. Audible alarm: If any errors occur during the initialization process, the onboard alarm will sound in a hastily repeated manner.
6. Drive tray LEDs should start flashing, indicating that the RAID control units are attempting to access the hard drives.

System firmware can be configured to support a delayed sequence for starting drives.

**NOTICE!**

The subsystem has been designed to run continuously. If a component fails, the fault can be corrected online.

5.4.4**LCD Screen**

When powering on the subsystem, wait for the front panel LCD screen to show “READY” or “No Host LUN” before turning on the host computer. Refer to *Figure 5.6* on how to read the screens.

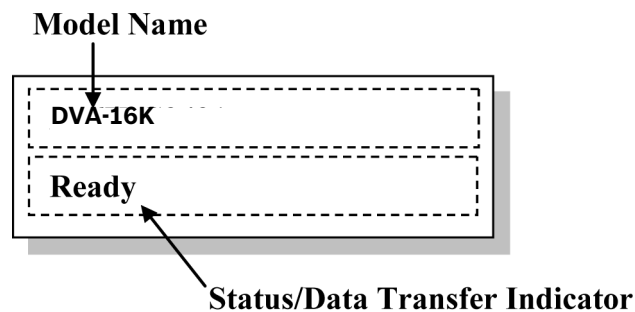

Fig. 5.6 The LCD Startup Screen

The LCD screen startup sequence is shown and described in the sequence below:

Initializing.... Please Wait...	This screen appears when the PSUs are turned on.
DVA-16K Modem Not Config	This screen appears after the initialization process. It clearly shows the model name.
DVA-16K 256MB RAM, Wait...	Verifying installed cache memory.
DVA-16K No Host LUN	System is ready. You can now start to configure the subsystem.

5.5 Power Off Procedure

If you wish to power down the RAID subsystem, please follow these steps:



NOTICE!

If you wish to power down the RAID subsystem, please ensure that no time-consuming processes, like a “logical drive parity” check or a “background scrub,” are running.

1. Stop I/O access to the system.
Use the software provided on the host computer to stop all IO accesses to the RAID subsystem. Please refer to the user’s manual that came with your host computer.
2. Flush the cache.
Use the “Shutdown Controller” function to flush all cached data. This prepares the RAID subsystem to be powered down.
3. Turn off the power.
Turn off the power switches at the top of the rear panel. Once the subsystem has been powered down, other devices that are connected to the subsystem may be powered down.

6 Subsystem Maintenance

6.1 Overview

6.1.1 About Subsystem Maintenance

Constant monitoring and maintenance of your RAID subsystem minimizes subsystem downtime and preserves the working integrity of the system for a longer period of time. If any of the subsystem components fail, they must be replaced as soon as possible.

CAUTION!

Do not remove a failed component from the subsystem until you have a replacement on hand. If you remove a failed component without replacing it, the internal airflow will be disrupted and the system will overheat, causing damage to the subsystem.

All of the following components can be replaced in case of failure:

1. Controller modules – *Section 6.2 Replacing Controller Module Components*
2. Memory module – *Section 6.3 DIMM Module Replacement*
3. BBU – *Section 6.4 Replacing a Faulty BBU Module*
4. PSU modules – *Section 6.5 Replacing a Faulty PSU Module*
5. Cooling modules – *Section 6.6 Cooling Module Maintenance*
6. Hard drives – *Section 6.7 Replacing a Failed Hard Drive*

6.1.2 General Notes on Component Replacement

- With the exception of the RAID controller module, all of the components on the RAID subsystem, including the PSU modules, cooling modules, and drive trays, are hot-swappable and can be changed while the subsystem is still in operation.
- Qualified technicians who are familiar with the RAID subsystem should be the only ones who make component replacements. If you are not familiar with the RAID subsystem or with RAID subsystem maintenance in general, it is strongly advised that you refer RAID subsystem maintenance to a suitably qualified maintenance technician.
- Normalized airflow depends upon the presence of all subsystem components. A subsystem component, even if it has failed, should not be removed from the subsystem until a replacement is readily at hand and can be quickly installed. Removing subsystem components without a replacement can lead to permanent subsystem damage.
- When replacing any hot-swappable component, caution should be taken to ensure that the components are handled in an appropriate manner. Rough or improper handling of components can lead to irreparable damage.
- When removing a controller module from the subsystem, ensure that the power has been turned off and that all precautionary measures, without exception, are adhered to. The controller board and the I/O board on which it is mounted are very sensitive components and can be easily damaged.

6.2 Replacing Controller Module Components

The controller module in the RAID subsystem consists of the following replaceable components:

- DDR RAM DIMM module
- Controller module

If any of these components fail, it must be replaced. To replace any of these components, the system power must first be turned off, and the controller module must be removed from the RAID subsystem.

6.2.1 Controller Module Maintenance Overview

- The controller module contains a DDR RAM DIMM module. When replacing the controller module, the DIMM module must be removed from the old controller module and reinstalled onto the new controller module.
- When replacing the controller module, always remember that the controller board is one of the most sensitive components in the RAID subsystem. All previously stipulated safety precautions (see *Section 3.3 Safety Precautions*) must be strictly adhered to. Failure to adhere to these precautions can result in permanent damage to the controller board, resulting in lengthy delays for the end user.
- Prior to replacing the controller module, it is imperative for your own safety to be sure that no power is being supplied to the system.

6.2.2 Removing the Controller Module

To remove the controller module:

1. Make sure there is no data access to the subsystem to avoid losing any data. Use the software provided on the host computer to stop all I/O accesses to the subsystem.
2. Power off the subsystem. Be sure to flush all cache data before powering off the subsystem. Turn off both power switches on the rear of the subsystem.
3. Disconnect all cables from the controller module. These include the SCSI cables connecting to input/output SCSI connectors, Ethernet cable connected to the LAN port, and any cables connected to the COM ports.
4. Remove the screws on the levers at the back of the controller module. (See *Figure 6.1*)

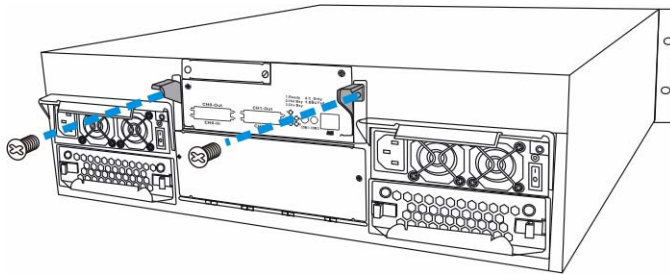

Fig. 6.1 Removing the Controller Module Screws

5. Remove the controller module. Once all the cables have been disconnected, press down the two (2) levers at the back of the controller module. The controller module will automatically be eased out of the controller module bay. Gently pull the controller module out of the subsystem. (See *Figure 6.2*)

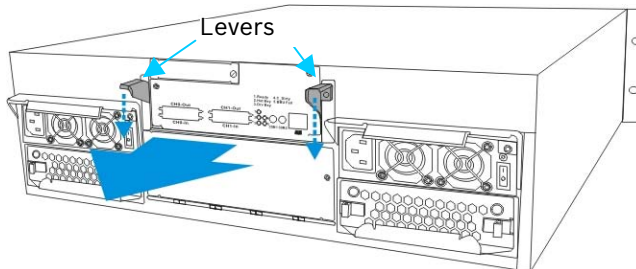

Fig. 6.2 Removing the Controller Module

6.2.3 Replacing the Controller Module

If the controller module itself has failed, it must be replaced. To replace a failed controller module:

1. Remove the controller module from the subsystem (see *Section 6.2.2 Removing the Controller Module*.) If the DIMM module is undamaged it can be removed and reinstalled on the new controller module. For instructions on removing and installing a DIMM module,

please see *Section 6.3 DIMM Module Replacement*.

2. Install the DIMM module onto the new controller module, making sure that the memory module is securely in place. (See *Section 6.3 DIMM Module Replacement*)
3. Install the controller module. Make sure the levers at the back of the controller module are down. Align the controller module with the controller module bay at the rear of the subsystem. Gently slide the controller module in. (See *Section 6.3 Installing the Controller Module*)

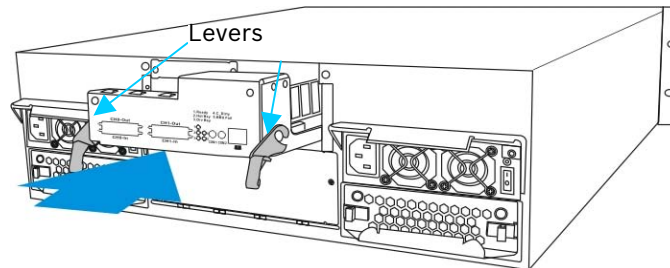

Fig. 6.3 Installing the Controller Module

4. Reposition the controller module. Once fully inserted, lift up the levers at the back of the controller module. This will set the controller module in the correct position. (See *Figure 6.4*)

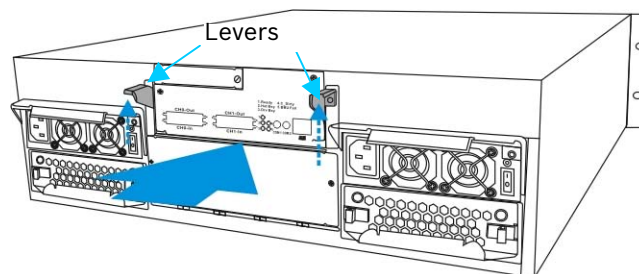

Fig. 6.4 Lifting the Controller Module Latches Upward

5. Secure the controller module to the subsystem. Install the two (2) screws on the levers to secure the controller module in place. (See *Figure 6.5*)

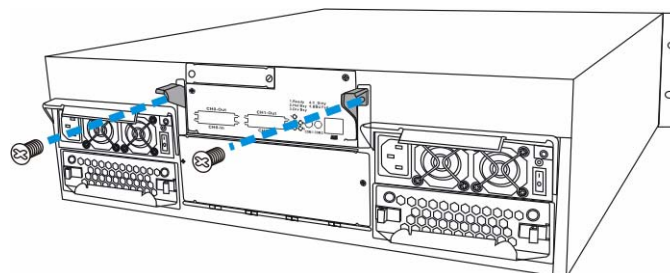

Fig. 6.5 Installing the Controller Module Screws

6. Re-attach all the cables that were removed. These include the cables that connect to the host and the expansion chassis, any Ethernet cable that was previously attached to the LAN port, and any cables that were attached to the COM ports.
7. The system is now ready to power up.

6.3 DIMM Module Replacement

The subsystem comes with a pre-installed 256MB capacity or above DDR RAM DIMM module on the controller. The controller supports memory up to 1GB. If a DDR RAM DIMM module has failed or a different size of DIMM module needs to be used, the pre-installed module must be

removed and the new one installed. Replacement and installation instructions are described fully below.

6.3.1 DIMM Module Considerations

If the memory module on the controller module is going to be replaced, the following issues must be considered when purchasing a replacement DIMM module:

- Pre-installed DDR RAM DIMM module: The RAID subsystem comes with a 256MB capacity or above DDR RAM DIMM pre-installed on the controller board and can support up to 1GB capacity. If you wish to change the size of the DDR DIMM, then a new DIMM must be installed.
- Purchasing considerations: When purchasing a DDR RAM DIMM module to install on the RAID subsystem controller board, contact your subsystem vendor for an updated list of compatible DIMM modules.
- DDR RAM DIMM module supported: The RAID subsystem supports DDR RAM DIMM modules with memory capacities between 256MB and 1GB.
- Installation considerations: When installing the DDR RAM DIMM module, it is necessary to remove the controller module. The controller board is more susceptible to damage than the other components and must be handled with extreme care.
- Secure installation: When replacing the DIMM module, make sure that the new DIMM module is firmly in place prior to re-installing the controller module. If the DIMM module is not firmly in place, the subsystem will not run and the whole procedure must be repeated.

6.3.2 DIMM Module Replacement Procedure



NOTICE!

If you are going to replace or upgrade a DIMM module, please follow the instructions below. If you do not want to replace or upgrade a DIMM module and would like to install a controller module, please go to *Section 6.2.3 Replacing the Controller Module*.

If a DIMM module fails or if a DIMM module with a higher memory capacity is required, the onboard DIMM module must be replaced. To replace the DIMM module:

1. Remove the controller module. (See *Section 6.2.2 Removing the Controller Module*)
2. Remove the previously installed DIMM module from the DIMM socket. Pull down the white clips on either side of the DIMM module to a 45-degree angle to dislodge the DIMM module. (See *Figure 6.6*)

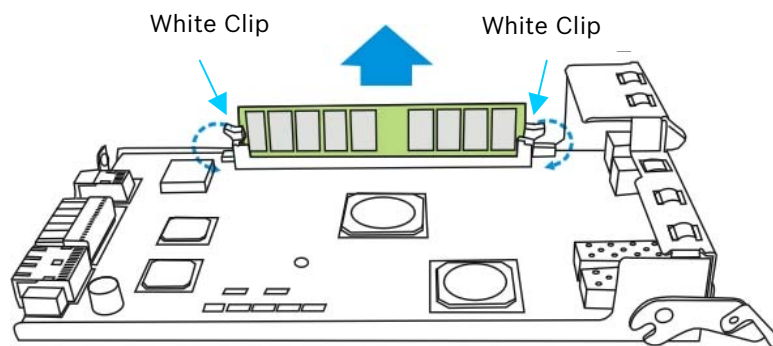

Fig. 6.6 Removing the DIMM Module

3. Re-insert the new DIMM module. Align the new DDR RAM DIMM module with the slot and gently (but firmly) push it in. The white clips on either side of the slot should automatically close and lock the new DIMM module into place. (See *Figure 6.7*)

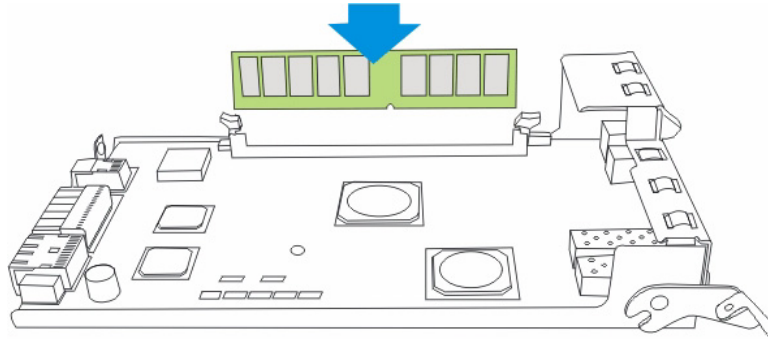

Fig. 6.7 Installing the DIMM Module

4. Install the controller module. Once the new DIMM module has been installed, place the controller module back in its original location. (See *Section 6.2.3 Replacing the Controller Module*)

6.4 Replacing a Faulty BBU Module

The BBU consists of a bracket, a battery pack, and a PCB board that connects to the back-plane board. If a BBU was installed and has failed, it should be replaced. To install or replace a BBU, please follow these steps.

6.4.1 BBU Warnings and Precautions

- Install or replace the BBU supplied by your subsystem vendors only. Use of battery cells provided otherwise will void our warranty.
- Always dispose of discharged or used batteries in an ecologically responsible manner. Dispose used BBU at authorized battery disposal sites only.
- Do not use nor leave the BBU near a heat source. Heat can melt the insulation and damage other safety features of battery cells, possibly leading it to acid leak, and result in flames or explosion.
- Do not immerse the BBU in water nor allow it to get wet. Its protective features can be damaged. Abnormal chemical reactions may occur, possibly causing functional defects, acid leak, and other hazardous results.
- Do not disassemble or modify the BBU. If disassembled, the BBU could leak acid, over-heat, emit smoke, burst and/or ignite.
- Do not pierce the BBU with a sharp object, strike it with a hammer, step on it, or throw it. These actions could damage or deform it, internal short-circuiting can occur, possibly causing functional defects, acid leak, and other hazardous results.
- If the BBU leaks, gives off a bad odor, generates heat, becomes discolored or deformed, or in any way appears abnormal during use, recharging or storage, immediately remove it from the subsystem and stop using it. If this is discovered when you first use the BBU, return it to Bosch or your system vendor.

6.4.2 Procedure



NOTICE!

The BBU is hot-swappable and can be replaced while the subsystem is running. However, a new module will only be recognized after a subsystem reset. Carefully select the time when the reset will be made in order to minimize the overall disruption to service.

1. Remove the faulty BBU from the chassis. Loosen the two (2) retention screws located on both sides of the BBU, then pull out the BBU. (See *Figure 6.8*)

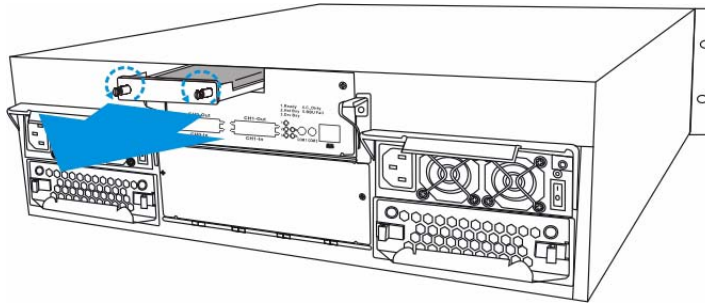

Fig. 6.8 Removing the BBU Module

2. Install the new BBU. Align the BBU with the slot, and then gently push the BBU into the slot.
3. Secure the BBU to the subsystem by fastening the two (2) retention screws on the back of the BBU (See *Figure 6.9*)

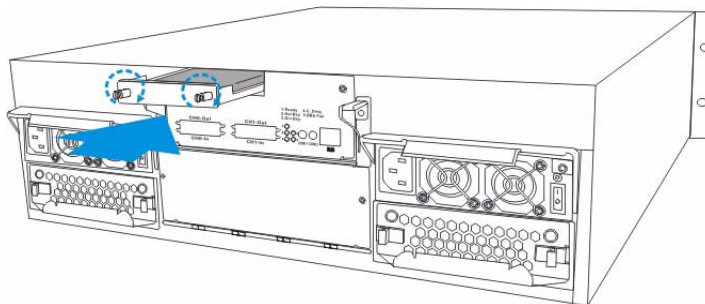

Fig. 6.9 Installing the BBU Module

4. Once the new BBU is correctly installed into the subsystem, the LED should start flashing to indicate that BBU is being charged. When the BBU is fully charged, the LED will light amber constantly.



NOTICE!

The life expectancy of a BBU is approximately 500 cycles. Follow the procedures above to replace an old BBU with a new BBU in order to maintain fault-tolerant subsystem functionalities.

6.5

Replacing a Faulty PSU Module

6.5.1

PSU Module Overview

- Two (2) redundant PSU modules: The RAID subsystem is preinstalled with two (2) 460W, fully redundant, hot-swappable PSU modules. These modules are located at the rear of the subsystem.
- PSU bracket: Each PSU module is permanently mounted in a two-level steel bracket, creating a single unit. The PSU is located in the upper level and a removable cooling module is mounted in the lower level. When removing the PSU from the subsystem, the cooling module is also being removed.
- PSU printing mark: Before you insert a new PSU, be sure that it has the same printing mark on its handle as that shown on the handle of a remaining PSU. Double-check to avoid mixing a PSU of previous series. (See *Figure 6.10*)

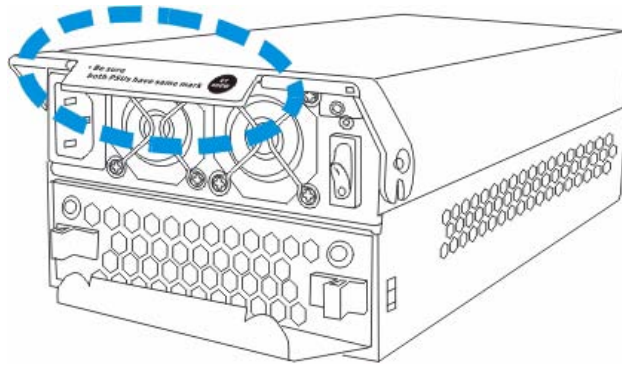

Fig. 6.10 Label on the PSU Handle

- Immediate replacement: When a PSU fails, it should be replaced immediately. However, do not remove the PSU module unless a replacement is readily available. Removing a PSU without a replacement will cause severe disruptions to the internal airflow and the subsystem will overheat, possibly causing irreparable damage to some of the subsystem components.

6.5.2 Replacing the PSU Module

CAUTION!

Although the PSU modules are fully redundant, it is not advisable to run the RAID subsystem with a single PSU module for an extended period of time. If the second PSU module fails, the subsystem will be shut down.

To replace a PSU, please follow these steps:

1. Turn off the PSU. Using the power switch located at the top of the rear panel, directly above the PSU module. (See *Figure 6.11*)
2. Remove the power cable that connects the RAID subsystem to the main power source. The power socket is found on the left side of each power supply module. (See *Figure 6.11*)

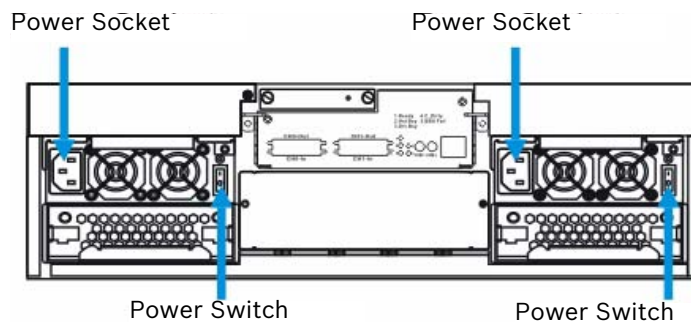

Fig. 6.11 Power Sockets and Power Switches

3. Remove the PSU retention screw at the top right-hand side of the PSU. (See *Figure 6.12*)

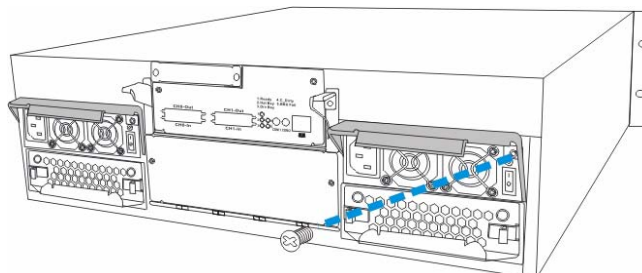

Fig. 6.12 Removing the PSU Retention Screw

- Remove the PSU module by pressing down the PSU handle found on the top of the PSU. (See *Figure 6.13*) This will dislodge the PSU module from the subsystem.

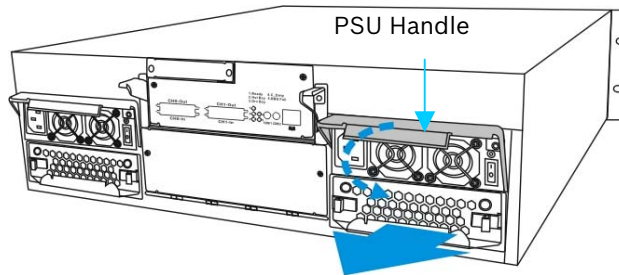

Fig. 6.13 Pressing Down the PSU Handle

- After the PSU module has been dislodged from the enclosure, use the handle to gently pull the PSU module out of the enclosure. (See *Figure 6.14*)

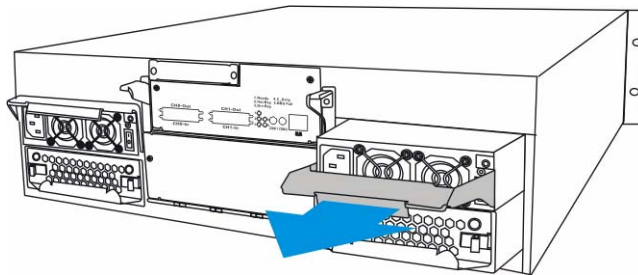

Fig. 6.14 Dislodging the PSU

- Remove the cooling module from the lower level of the PSU module. Please refer to *Section 6.6 Cooling Module Maintenance*.

CAUTION!

- When a PSU is pulled out of the chassis, the cooling module beneath the PSU is removed from the chassis at the same time.
- It is recommended that the replacement procedure is completed in less than five (5) minutes to prevent the subsystem from overheating.

- Insert the previously removed cooling module into the new PSU module. (See *Section 6.6 Cooling Module Maintenance*.)
- Insert the new PSU module into the subsystem. Make sure the ejection handle is in its down position so that the saddle notches on the lower edges of the handle can lock on to the edge metal brackets along the chassis inner walls. Push the PSU into the slot and pull the handle upward to secure the module. (See *Figure 6.16*)

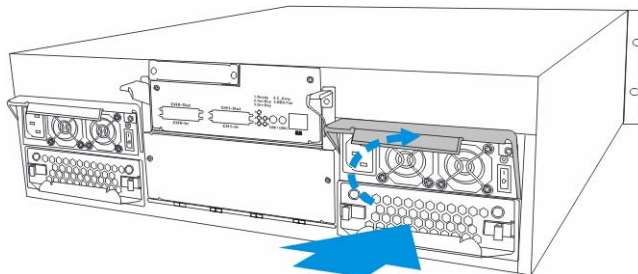

Fig. 6.15 Installing the new PSU Module

- Secure the PSU to the subsystem by inserting the retention screw to the PSU. (See *Figure 6.16*)

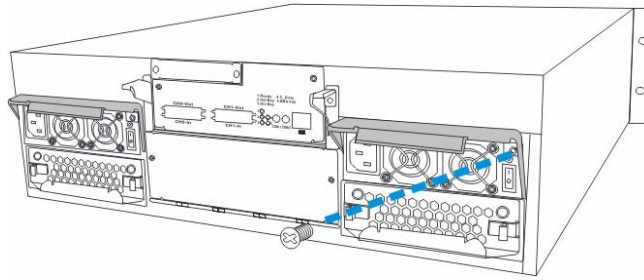

Fig. 6.16 Fastening the PSU Retention Screw

10. Replace the power cable that connects the PSU module to the main power source.
11. Turn the PSU module on.

6.6 Cooling Module Maintenance

6.6.1 Cooling Module Overview

- Redundant cooling modules: The RAID subsystem is equipped with two (2) redundant, hot-swappable, dual-blower cooling modules located on the lower level of the subsystem rear panel. These cooling modules control the internal operational temperature of the subsystem and therefore their working integrity should be maintained at all times.
- Detecting a failed cooling module: If a cooling module fails, the LED located at the back of the module, an audible alarm, the firmware, the Bosch RAIDWatch panel view, or the Configuration Client can notify you.
- Replacing a cooling module: Once you are notified that a cooling module has failed, it should be replaced as soon as possible. A failed cooling module should only be removed from the subsystem when you have a replacement module immediately available that can be installed as soon as the failed cooling module has been removed.

CAUTION!

The latches at the back of the cooling module secure the cooling module into the enclosure. If these latches are broken, the warranty on the cooling module will be void.

6.6.2 Replacing a Cooling Module

If one of the cooling modules fails, it must be replaced as soon as possible. The cooling modules are secured to the chassis with the two (2) black latches located on the rear surface of the module itself. To replace the cooling module, please follow these steps:

CAUTION!

- Although the cooling modules are fully redundant, it is not advisable to run the RAID subsystem with a single cooling module for an extended period of time. If the remaining cooling module fails, the system is at risk of sustaining irreparable damage.
 - Keep a failed module in its enclosure bay until a replacement unit is in hand.
-

1. To remove the cooling module, pull both side latches toward the center of the cooling module. Withdraw the cooling module from the subsystem by gently pulling on the silver handle at the bottom of the module. (See *Figure 6.17*)

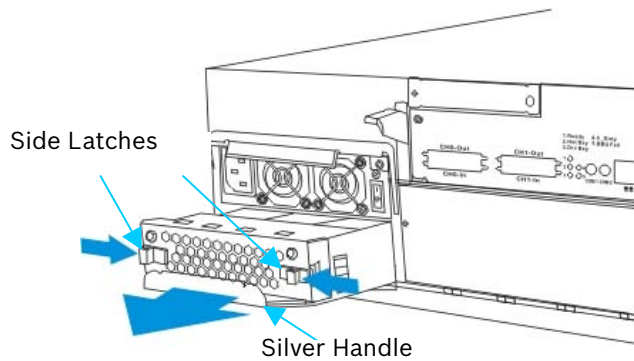

Fig. 6.17 Removing the Cooling Module

2. Install the new cooling module by aligning the module with the cooling module slot on the lower section of the PSU module and gently sliding it in. The latches will hold the module in place. (See *Figure 6.18*)

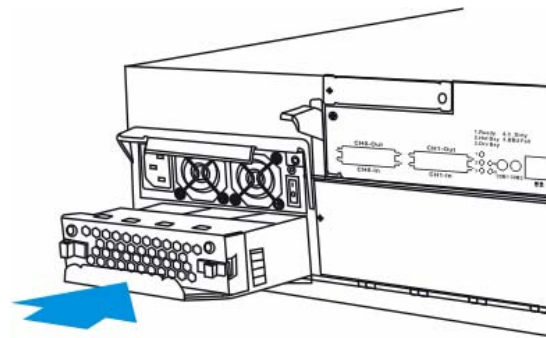

Fig. 6.18 Installing the new Cooling Module

6.7 Replacing a Failed Hard Drive

Hard drives for the subsystem can be purchased separately. When purchasing the hard drives, the following factors should be considered:

Capacity (MB/GB): Use drives with the same capacity. RAID arrays use a “least-common-denominator” approach. The maximum capacity of each drive used in the array is the maximum capacity of the smallest drive. Choose big drives with the same storage capacity.

Profile: The drive trays and bays of the system are designed for 3.5-inch wide x 1-inch-high hard drives. It is highly recommended that you do not try to use drives of any other size.

Drive type: The RAID subsystem described in this manual can use SATA-I or SATA-II hard drives. Please ensure that you purchase the correct hard drives.

CAUTION!

The hard drives and drive trays should only be installed into the subsystem after the subsystem has been mounted into a rack cabinet. If the hard drives are installed first, the subsystem will be too heavy to lift and the possible impact during installation may damage your drives.

CAUTION!

- Handle hard drives with extreme care. Hard drives are very delicate. Dropping a drive onto a hard surface (even from a short distance) and hitting or touching the circuits on the drives with your tools may cause damage to the drives.
- Observe all ESD prevention methods when installing drives.
- Only use screws supplied with the drive canisters. Longer screws may damage the drive.

6.7.1 Hard Drive Maintenance Overview

- Hot-swappable drive trays: The drive trays are all hot-swappable. If a hard drive fails, it can be replaced while the subsystem is still running.
- Handles: If the failed hard drive is behind either the left or right front handle, unfold the handles to open the front access to the drive trays. (See *Figure 6.19*)

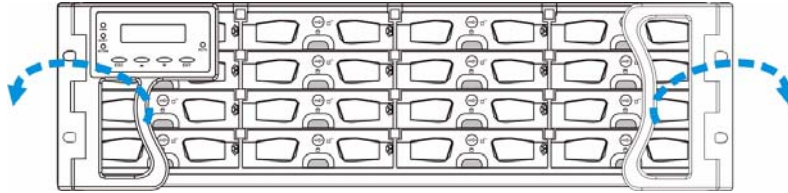

Fig. 6.19 Open the Front Handles

- Open flap: Once the flap on the drive tray has been opened, the drive tray must be removed from the subsystem. Failure to remove the drive tray from the subsystem after the flap has been opened may cause data errors.
- Remove drives slowly: When removing a drive tray from the RAID subsystem, pull the drive tray out only about one inch and then wait for at least 30 seconds for the hard drive motor to spin down before taking it out completely. Any impact to the hard drive while the drive motor is spinning can damage the drive.
- Keep a replacement on hand: If a hard drive has failed, make sure you have a replacement hard drive readily available before removing the failed drive from the subsystem. Do not leave the drive tray slot open for an extended period of time or the normalized airflow will be disrupted and subsystem components will overheat and may become permanently damaged.

6.7.2 Replacing a Hard Drive

When a hard drive fails, it needs to be replaced. To replace a hard drive, please follow these steps:

CAUTION!

The hard drive is fragile—always handle with extreme care. Do not drop the hard drive; always be slow, gentle, and careful when setting down a hard drive. Only handle the hard drive by the edges, and avoid touching any components or connectors.

1. Identify the drive tray that contains the hard drive that needs to be replaced.
2. Open the key-lock. To remove the drive tray from the enclosure, the key-lock must be unlocked. (See *Figure 6.20*) To do this, turn the key-lock on the front of the drive tray until the groove on its face is in a horizontal orientation.

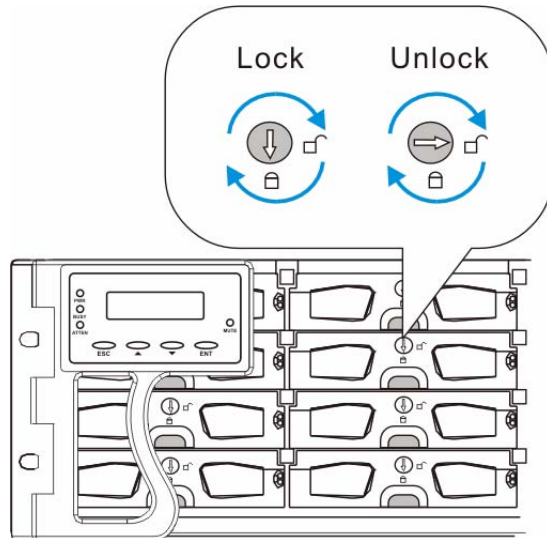

Fig. 6.20 Drive Tray Key-lock Rotation

- Open the front flap by pushing the button at the front of the drive tray. (See *Figure 6.21*) The drive tray front flap will automatically be lifted and the drive tray will be dislodged from the chassis.

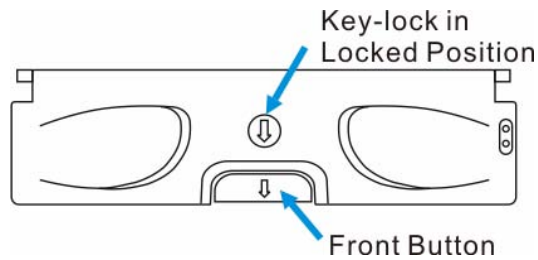

Fig. 6.21 Front View of an Individual Drive Tray

- Remove the drive tray with the hard drive, gently and carefully withdrawing the drive tray with hard drive from the chassis.
- Remove the four (4) retention screws located on the sides of the drive tray (two on each side.) (See *Figure 6.22*)

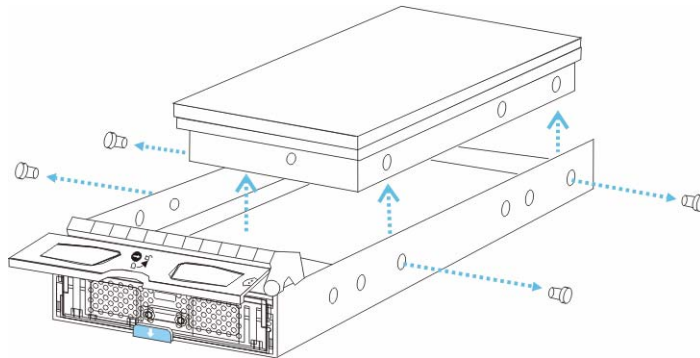

Fig. 6.22 Removing the SATA Hard Drive

- Install the new hard drive.

7 Appendix: Specifications

7.1 Technical Specifications

Environmental Specifications	
Humidity	5 to 95% (non condensing)
Temperature	Operating: 0° to 40°C Non-operating: -20° to 60°C
Altitude	Operating: 0 - 12,000 ft Packaging: 0 - 20,000 ft

Power Requirements	
Input Voltage	100VAC @ 10A 240VAC @ 5A with PFC (auto-switching)
Frequency	47 – 63Hz
Power Consumption	460W

Dimensions	
Height	With handle: 131mm Without handle: 130mm
Width	With handle: 482.6mm Without handle: 445mm
Length	With handle: 504.3mm Without handle: 488.2mm
Weight	Net weight: 28.5 Kg Gross weight: 30.5 Kg

EMI/EMC	
<ul style="list-style-type: none"> • FCC Class B • CE 	

Safety Requirements	
<ul style="list-style-type: none"> • UL60950 • CB 	

Shock	
Half-sine	Operating: 10G peak, 11ms duration Non-operating: 100G, 180 in/sec 240G, 2ms, half-sine
Square	240G, 2ms, half-sine

Vibration	
Operating	5 - 500Hz, 0.2G, X/Y/Z
Non-operating	5 - 500Hz, 1.0G, X/Y/Z

Warning Alarms	
<ul style="list-style-type: none"> • Audible alarms • System LEDs • Event notification via the Bosch RAIDWatch Manager, LCD screen, or RS-232C terminal 	

7.2 Controller Specifications

Specifications	
RAID Levels	0, 1, (0 + 1), 3, 5, 10, 30, 50, JBOD, and Non-RAID disk spanning
Host O/S Compatibility	Host O/S independent
Host Interface	SCSI-320
Host Channels	Pre-configured host channels
Drive Interface	Supports up to 16 channels of SATA-II
Drive Channels	All drive channels are pre-set and cannot be changed.
Cache Mode	Write-through or write-back

Specifications	
Cache Memory	Up to 1GB DDR RAM DIMM memory with/without ECC
Number of LUNs	Up to 32 per SCSI ID
Multiple Target IDs/Host Channel	Yes
Aliases for Target IDs	Yes
Firmware on Flash Memory	Yes
Drive Hot-swapping	Yes
CPU	600MHz PowerPC 750FX
SCSI Controllers	LSI 1030 T
DIMM Slot	One 184-pin DIMM module
PC-133 Support	Yes
ASIC	64-bit chipset
Flash ROM	32Mbit (4MB)
NVRAM	32KB with RTC
Hardware XOR	Yes
Real-time Clock	For event messages with time record

7.3 Drive Tray Specifications

Specifications	
Height	28mm
Width	110mm
Depth	218.92mm
Key-lock	Yes

7.4 Power Supply Specifications

Specifications		
Nominal Power	460W with active PFC	
DC Output	12.0V: 32A (Max.) 5.0V: 32A (Max.) 3.3V: 30A (Max.)	
Input Frequency	47 ~ 63Hz	
Input Voltage	100VAC @ 10A – 240VAC @ 5A with PFC	
Power Factor Correction	Yes	
Hold-up Time	At least 16ms at 115/230VAC full load after a loss of AC input	
I ² C	Through backplane to controller	
Over-temperature Protection	Lost cooling or excessive ambient temperature	
Cooling Fans	Two fans for each unit (inside PSU)	
Temperature	Operating: 0°C to 50°C (32°F to 122°F) Storage: -40°C to 70°C (-40°F to 158°F)	
Humidity	Operating: 20% ~ 90% non-condensing Non-operating: 5% ~ 95% non-condensing	
Altitude	Operating: 0 - 10,000 ft Non-operating: 0 - 40,000 ft	
Acoustic Noise	115V input, full load of +5V; 0.5A of +12V	50 dB max.

7.5 Cooling Module Specifications

Specifications	
Max. Air Flow	High speed: 31.8 CFM Low speed: 20.1 CFM
Input Power	9 W max.
Input Current	0.89A max.
Rated Voltage	DC 12V
Acoustic Noise	High speed: 55dB max. Low speed: 44dB max.
Temperature	Operating: -10 to +60°C Storage: -20 to +70°C

7.6 RAID Management

Specifications	
Configuration	<ul style="list-style-type: none"> Text-based firmware-embedded utility over RS-232C through the included serial cable LCD keypad panel The Bosch RAIDWatch Manager program using in-band or Ethernet connection
Performance Monitoring	Yes
Remote Control and Monitoring	Yes
Event Broadcast/Alert	Yes, via Java-based Bosch RAIDWatch Manager and Event Monitor
Event Notification	Yes, via the Bosch RAIDWatch Configuration Client sub-module
Hardware Connection	In-band over SCSI/Fiber, out-of-band via Ethernet or RS232C
Configuration on Disk	Configuration data stored on disks for logical drive assemblies to exist after controller replacement.
Failure Indicator	Faults are indicated via alarm, module LED indicators, LCD panel, Bosch RAIDWatch Manager, or terminal emulation.

7.7 Fault Tolerance Management

Specifications	
Drive S.M.A.R.T Support	Yes, with user-configurable detect only, clone and replace, and perpetual clone functions.
Battery Back-up Option	Yes
Automatic Drive Failure Detection	Yes
Automatic Rebuild on Spare Drives	Yes
Regenerate Logical Drive Parity	Yes
Bad Block Reassignment	Yes
Automatic Rebuild upon Failed Drive Replacement	Yes
Manual Clone of Suspected Failed Drive	Yes
Concurrent Rebuild on Multiple Drives in a RAID (0 + 1) Logical Drive	Yes
Salvage the 2nd Temporary Failed Drive in a RAID 1, 3 or 5 Logical Drive	Yes
Salvage the 1st Temporary Failed Drive in a RAID 0 Logical Drive	Yes

8 Appendix: Spare Parts and Accessories

8.1 Spare Parts

The active components and their model names are listed in the following tables:

Model Name	Description
DVA-ADTK-000A	Drive tray, Type-III bezel and Type-II LED lightpipe
DVA-ADTK-050A	Drive tray including 500 GB Hitachi SATA drive
DVA-SPKK-16A	Power supply module, enhanced 16-bay subsystem, 460W capacity
DVA-SFAK-16A	Cooling fan module for enhanced 16-bay subsystem
DVA-SCDK-16A	SCSI to SATA RAID controller module, 2 SCSI-320 host channels, 16 SATA-II drive channels, enhanced 3U enclosure, 2 dual-stacked VHDCI connectors, 256MB DDR memory included

Table 8.1 Spare Parts

8.2 Accessories

The accessories and their model names are listed in the table below:

Model Name	Description
DVA-SBBK-00A	Battery cell pack, Li-Ion, enhanced 16-bay sub-systems
DVA-ACON-HD68A	SCSI external round cable, DB68 to VHDCI
DVA-ACON-VD68A	SCSI external round cable, VHDCI to VHDCI
DVA-ACON-VD680A	SCSI external round cable, VHDCI to VHDCI (0,5 m)
DVA-ASRK-36A	Slide rail assembly for enhanced 3U enclosures, 23"~36" rack depth
DVA-ASRK-32A	Slide rail assembly for enhanced 3U enclosures, 23"~32" rack depth

Table 8.2 Accessories

9 Appendix: Pin Outs

9.1 VHDCI SCSI Port Pin Outs

VHDCI SCSI port pin out definitions are shown below.

(NC = No Connection, GND = Ground, and TPWR = Terminator Power)

Pin	Name	Pin	Name
1	SD12+	35	SD12-
2	SD13+	36	SD13-
3	SD14+	37	SD14-
4	SD15+	38	SD15-
5	SDP1+	39	SDP1-
6	SD0+	40	SD0-
7	SD1+	41	SD1-
8	SD2+	42	SD2-
9	SD3+	43	SD3-
10	SD4+	44	SD4-
11	SD5+	45	SD5-
12	SD6+	46	SD6-
13	SD7+	47	SD7-
14	SDP0+	48	SDP0-
15	GND	49	GND
16	DIFSENS	50	GND
17	TPWR	51	TPWR
18	TPWR	52	TPWR
19	NC	53	NC
20	GND	54	GND
21	SATN+	55	SATN-
22	GND	56	GND
23	SBSY+	57	SBSY-
24	SACK+	58	SACK-
25	SRST+	59	SRST-
26	SMSG+	60	SMSG-
27	SSEL+	61	SSEL-
28	SC_D+	62	SC_D-
29	SREQ+	63	SREQ-
30	SI_O+	64	SI_O-
31	SD8+	65	SD8-
32	SD9+	66	SD9-
33	SD10+	67	SD10-
34	SD11+	68	SD11-

Table 9.1 SCSI Port Pin Outs

9.2 DB9 Audio Jack Pin Outs

This cable is able to connect the COM1 serial port on the controller module rear panel for terminal emulation management.

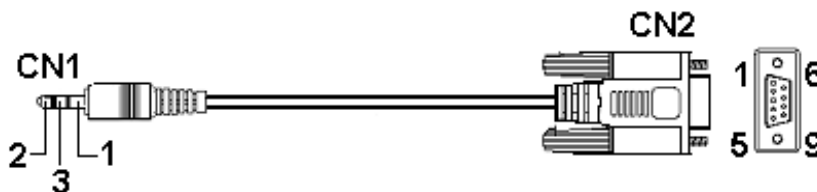

Fig. 9.1 RS-232C (Audio Jack) Pin Outs

CN1 Pin Number	Pin Name
1	Ground
2	TXD
3	RXD

CN2 Pin Number	Pin Name
1	NC
2	RXD
3	TXD
4	DTR (Shorted)
5	GND
6	DSR (Shorted)
7	RTS (Shorted)
8	CTS (Shorted)
9	NC

Table 9.2 RS-232C (Audio Jack) Pin Out Definitions

9.3 DB9 Audio Jack UPS Cable Pin Outs

Use this cable to connect the COM2 serial port to UPS.

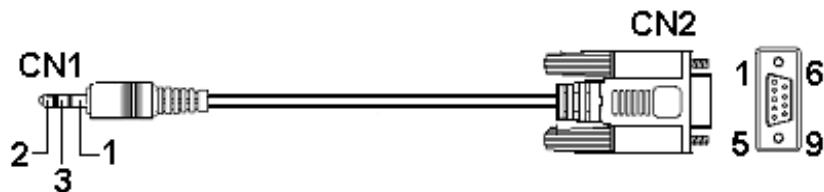

Fig. 9.2 RS-232C (Audio Jack) Pin Outs

CN1 Pin Number	Pin Name
1	Ground
2	TXD
3	RXD

CN2 Pin Number	Pin Name
1	TXD
2	RXD
3	NA
4	NA
5	NA
6	NA
7	NA
8	NA
9	Ground

Table 9.3 RS-232C (Audio Jack) Pin Out Definitions

9.4 Null Modem

Swap pin 2 and pin 3
Swap pin 4 and pin 6
Swap pin 7 and pin 8

Table 9.4 Null Modem Pin Outs

9.5 Ethernet Port Pin Outs

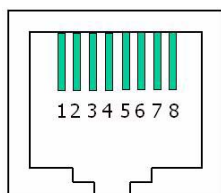

Fig. 9.3 LAN Port Pin Outs

Pin	Pin Name	Pin	Pin Name
1	LAN_TXP	5	N2
2	LAN_TXN	6	LAN_RXN
3	LAN_RXP	7	N1
4	N2	8	N1

Table 9.5 Ethernet Port Pin Outs

9.6 Main Power

IEC-type receptacle.

10 Index

A

airflow 18
airflow clearance 18
ambient temperature 36
ASIC 8
audible alarm 16, 23, 29
audio jack serial port 14
authorized battery disposal sites 43

B

backplane 12
battery backup unit 8
BBU 8
BBU module 14, 27, 43
BBU Warnings 43
Bosch RAIDWatch 16, 23

C

cable connection 36
cabling 18
capacity 48
chassis 8, 10
chassis ID 35
component check 18
configuration client 23
controller initialization 26
controller module 13, 24, 39, 40
controller module LEDs 26
cooling module 12, 15, 24, 28, 39, 47
cooling module side latches 47
cooling module slot 15

D

DAEMON 23
daisy chain 34
Data Compare Errors 49
DDR 12
DDR RAM 42
device-status-indicating LED 23
DIMM 40, 42
DIMM module 12, 39, 42
DIMM socket 13
drive bay 11
drive bays 13, 48
drive ID 10, 11
drive tray 13, 20, 36, 48, 49
drive tray LEDs 25
drive trays 24
dummy plate 12

E

easily accessible button 13
electrical earth connection 19
electrostatic discharge 18
ESD damage 19
Ethernet port 23, 27
event notification 17

F

failover software 33, 35
fan failure 15
fan speed 15
faulty module 18

firmware 16, 23
front flap 21, 49
front panel 10, 12

G

groove 20
GUI 16

H

handles 49
hard drive 18, 36, 39, 48, 49
host channel 13, 14
host connection 31, 32
host redundancy 33
hot-swap mechanism 12
hot-swappable 39
 mechanism 8

I

I2C 23, 30
I2C bus 16
initial screen 12
international transportation regulation 14
IO access 38, 40

K

key-lock 13

L

LAN Port LEDs 27
LCD 37
LCD display 24
LCD panel 11, 12, 24
LED 16
left handle 11

M

management software 35
memory capacity 14, 42
memory module 36
monitoring methods 16
mute button 24

N

normalized airflow 17, 39
numbering of drive trays 11

O

over-voltage 15

P

path redundancy 33
PC Hyper Terminal 23
permanent IP 27
physical dimensions 10
power cable 36
power down 38
power on 35
power outlet 18
power range 18
power socket 36
power supply unit 11
power switch 12, 36
PSU 11, 12, 15, 28, 39, 45
PSU Bracket 44
PSU Module 24

R

rack cabinet 18
rackmounting 20
rear panel 11,12
retention screws 18
right handle 11
RJ-45 27

S

safety precautions 18,40
SATA drives 48
SATA-II drives 48
SCSI cable 31
SCSI-320 8
Self-monitoring 23
sensors 28
single host 32
startup 37
static electricity 19
static free 18
subsystem maintenance 39

T

thermal notice 18
threshold values 29
transfer rates 31

V

ventilation 18
VHDCI-SCSI connector 13

Bosch Security System

Robert-Koch-Straße 100

D-85521 Ottobrunn

Germany

Telefon +49 (89) 6290-0

Fax +49 (89) 6290-1020

www.bosch-securitysystems.com

© Bosch Security System, 2006