



Touch-Activated Response Gaming  
Entertainment Table

---

**User Manual**

# Table of Contents

---

<b>About TARGET</b>	<b>3</b>
<b>The Team</b>	<b>3</b>
<b>About This Manual</b>	<b>3</b>
<b>How It Works</b>	<b>4</b>
<i>Input</i>	
<i>Processing</i>	
<i>Output</i>	
<i>System Operation</i>	
<b>Setting Up The Table</b>	<b>6</b>
<b>Using TARGET</b>	<b>6</b>
<b>Calibrating CCV</b>	<b>7</b>
<b>Using CCV</b>	<b>7</b>
<b>Aligning the Lasers</b>	<b>7</b>
<b>Other Maintenance</b>	<b>9</b>
<i>Projector</i>	
<i>Mirror</i>	
<i>Camera</i>	
<i>Surface</i>	
<i>Lasers</i>	
<i>Intel Atom</i>	
<b>Appendix</b>	<b>11</b>

# About TARGET

In the world of entertainment, anyone who has ever wanted a pool table, an air hockey table, or similar product has probably been deterred by the cost and difficulty associated with buying and installing one. These products can cost thousands of dollars and having several different game tables can take up a lot of space. For those wanting several game tables, there are existing multi-game systems that save space, but they can be just as costly and difficult to set up. TARGET, or Touch-Activated Response Gaming Entertainment Table, is an interactive touch surface table designed for multiple game applications. It is an alternative system that is not only cost effective and hassle-free, but also provides a fun and innovative way for gamers to play their favorite games using a unique touch interface. TARGET was created as a Senior Design Project in 2011 by Team Siqueira.

## The Team

Team Siqueira:

- Patrick DeRoy: Electrical Engineering '11
- Marc Perras: Computer Systems Engineering '11
- Cory Gorman: Computer Systems Engineering '11

Team Advisor: Paul Siqueira, Associate Professor

## About This Manual

As TARGET is meant to serve as an entertainment system, it is important to inform its users of the important aspects of the system. This manual aims at demonstrating how to set up, use, and maintain the TARGET system. It will include specific instructions on how to operate the table normally, fix any problems, and lists warnings and problems to avoid. In this way, TARGET is sure to provide endless hours of fun to those who use it.

## How It Works

The operation of the table can be broken down into components for input, processing, and output.

### *Input:*

The input to the system consists of user touches on an acrylic panel. The touch input is achieved using a technique known as Laser Light Plane, or LLP. In each corner of the surface panel, an laser module is placed. These laser modules project 780nm infrared light through a line-generating lens, effectively creating a plane of light above the surface of the table. This laser light plane (for which the technique is named) is a mere millimeter above the surface. When an object, such as a finger, crosses the plane, the light is scattered, and some of it goes downward into the table. This is captured by a Playstation 3 Eye camera (modified for filtering out everything except 780nm infrared light) and used as input to the system. Figure 1 below shows how LLP is implemented in our system.

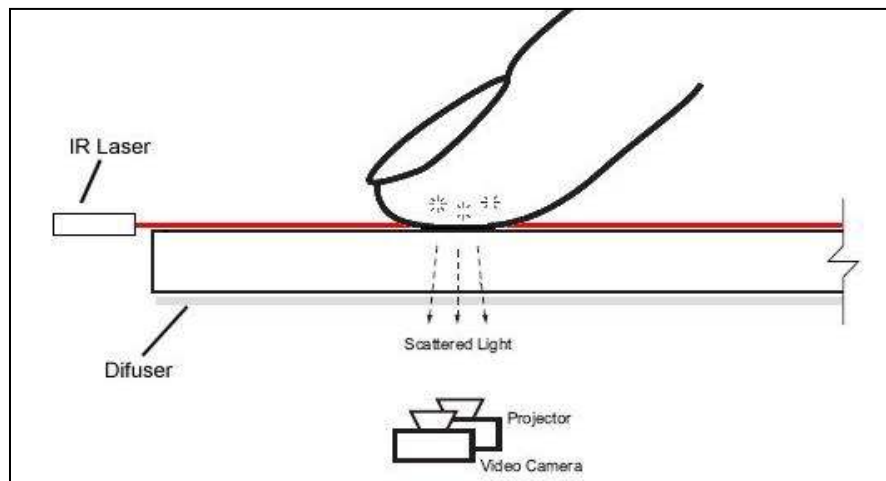

*Figure 1: Illustration of laser light plane illumination.*

### *Processing:*

Community Core Vision, or CCV, is an open-source application used for capturing a video input stream and outputting tracking data for the touches it captures. It processes the image it receives from the camera to find the locations of the users' touches in a coordinate space. As it gathers tracking data, it sends the data as a UDP packet to a local network port using a protocol called TUIO. These packets are received using a TUIO listener within the TARGET software. The software uses this information to change the current application state and process game graphics to reflect the users' actions. This processing is performed on the Intel Atom, running 64-bit Linux Ubuntu.

### *Output:*

The output image, meaning the updated game graphics, are sent via VGA to a projector that displays the image at the surface.

## System Operation:

The following figure shows the block diagram for the TARGET system:

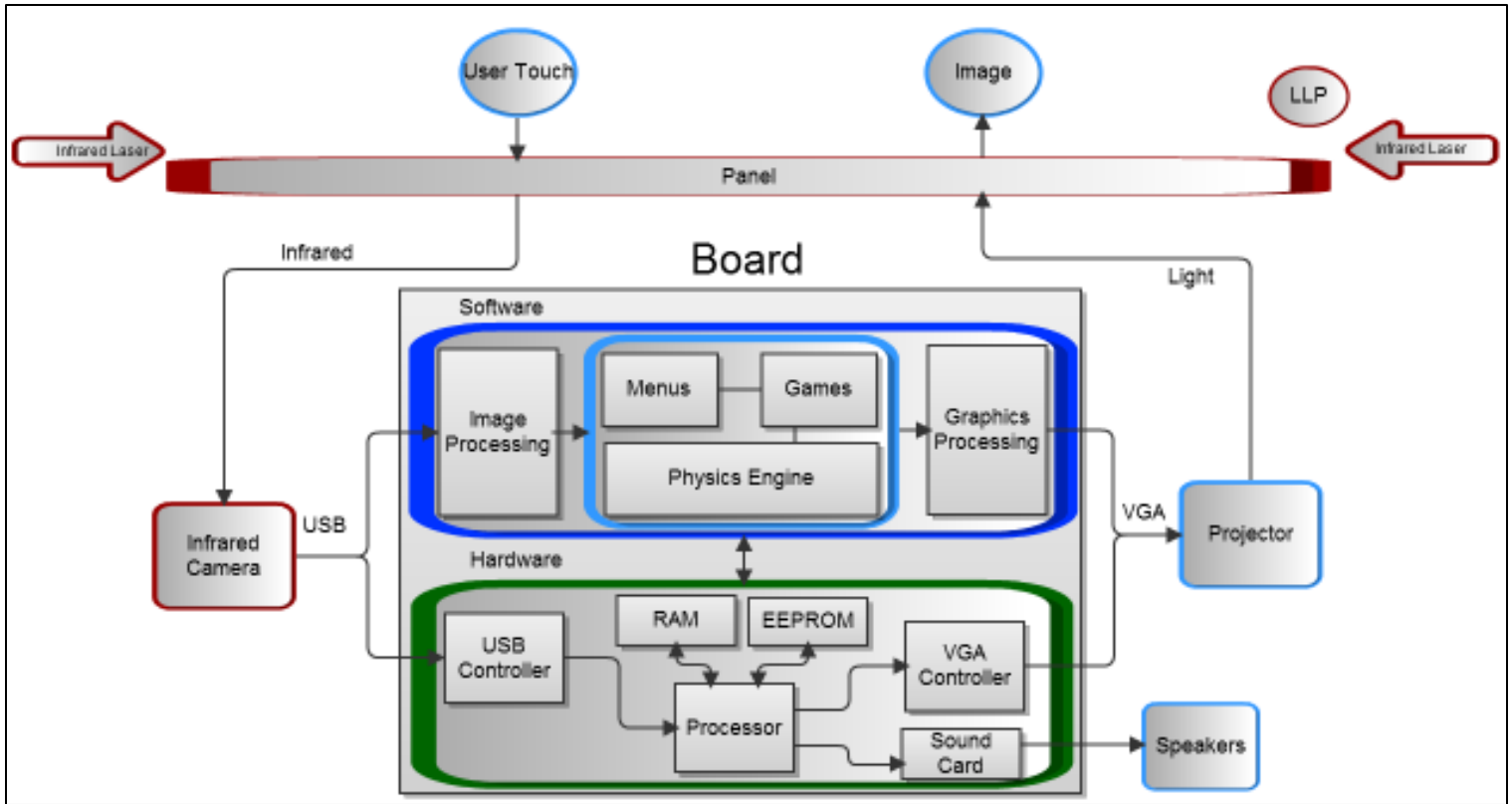

Figure 2: Block Diagram for TARGET

In analyzing the block diagram, begin at the top. The user will touch the surface to control the game. By doing so, their finger crosses the laser plane and this is seen by the camera. The camera feed is captured in CCV and processes the feed to get the touch data. The touch data is received by the TUIO listener and becomes the input to the gaming system (the menus and the game applications). After the updates are made to the game state and graphics, the new graphics are sent to the projector to be displayed at the surface. Essentially, the user will touch the table and see a reaction that is accurate and realistic, just as they would expect for a normal gaming table.

For more detailed information on how the system works, please refer to the Final Report for TARGET located in the appendix at the end of this manual.

## Setting Up The Table

1. Plug in the chord in the back of the table into a wall outlet.
2. Turn on the Intel Atom and raise the keyboard tray on the left door of the table.
  - a. Slide the wooden blocks on the sides of the keyboard tray down to hold up the tray. There is room on the tray for the mouse as well.
3. Turn on the projector and press the "Computer" button so that it displays the desktop on the surface.
4. When Ubuntu boots, enter "target" as the password (without quotes).
5. After logging in, open Community Core Vision and calibrate it (see Calibrating CCV section).
6. Put CCV into Mini mode by pressing the space bar on the keyboard and minimize the window.
7. Run the application for TARGET.
8. Enjoy the entertainment it has to offer!

## Using TARGET

1. Upon running the TARGET application, you will see a welcome screen that shows the TARGET logo.
2. To access the game menus, touch your finger to the table and slide it to the left (just as you would with similar touch devices, such as the iPod touch). There are two games: Air Hockey and Mash.
3. The first menu is for Air Hockey. In this menu, you can choose what score you would like to play to, whether you want to play "Win by 2" rules, and whether you want to use touch prediction. Once you have chosen the options you would like, press play and have a blast!
  - a. Touch prediction is used to make the user's control more accurate by almost eliminating delay. This option was used mainly to illustrate the difference between the delay with and without prediction. For the most part, this option will likely always be on.
4. The next menu is for Mash. In this menu, you can choose how long you would like the game to last. Then push play and enjoy!

NOTE: In each game, there is a button to start a new game (with the same settings) and a button to quit the game and return to the menu.

5. There is also another screen after Mash that contains acknowledgments to those who helped make TARGET a success.
6. To exit the TARGET program entirely, press "q" on the keyboard in the main menu.

## Calibrating CCV

1. After opening Community Core Vision, press “c” on the keyboard. This will put CCV into calibration mode.
2. The calibration screen shows many green “+” symbols on the surface. For the best calibration, it is best to have many of these symbols.
  - a. To change the number of symbols, follow the instructions on the calibration screen.
3. Before calibrating, make sure there are no touches on the surface.
4. Press “b” on the keyboard to remove the background image. The background image is what CCV tracks against.
5. After placing the adequate amount of “+” symbols and removing the background, press “c” to begin the calibration.
6. A red circle will appear around one of the green “+” symbols. This indicates that you need to touch it. Touch the green “+” and hold down until the circle becomes light blue. Do this for each “+” symbol.
7. CCV is now calibrated.
8. Press “x” to exit from the calibration screen.

## Using CCV

CCV has two modes: Normal mode and Mini mode. In Normal mode, there are two video feeds. The one on the left is the raw video feed and the one on the right is the tracked image displaying unique IDs for each tracked object. There are settings under the tracked image as well as at the bottom of the CCV window for adjusting the tracking. There are also settings on the right of the CCV window, but the only one to worry about is the option TUIO UDP. This option should be checked as this is how the tracking data is sent to the TARGET software. In Mini mode, the video feed displayed is the tracked image. It also displays the frame rate (which should be 80+ fps). This mode should be used while running the TARGET software. To toggle between Normal mode and Mini mode, use the space bar on the keyboard. To close CCV at any time, press “Esc” on the keyboard.

## Aligning the Lasers

For the best operation of the table, it is very important that the lasers are adjusted properly. In the “How It Works” section of this manual, it was explained that the lasers must be aligned very closely to the surface of the table.

**WARNING:** Before doing any adjustments, make sure to TURN OFF THE LASERS as there is a chance they could be harmful if you look directly at them. The best way to do this is to make sure the table is unplugged before beginning.

Remove the panels from the top of the table. BE CAREFUL not to touch the nails once you pull off these panels. You will notice that there is a bank of four switches. They are used to turn the lasers on and off. You will also notice the four laser mounts on each corner of the table. These mounts are made of two parts: the tube that holds the laser and the metal plate used to adjust them. For the tube, you need only make sure that the screws are tight to hold the laser in place. On the metal plate, there are four screws that can be loosened or tightened to adjust the height and angle of the laser. There are foam pieces under each mount that allow this adjustment to happen. Each laser should be aligned properly for the best infrared coverage of the surface.

When aligning the lasers, make sure all of the switches for the lasers are turned off and then plug in the table. For safety reasons, stand BEHIND the laser you want to align and turn its switch on. Place a wood block on the surface in front of the laser. Using a digital camera, such as a cell phone camera, aim at the wood block. You should be able to see a thin red line of IR light. This line should be completely level and really close to the surface. Adjust the screws on the metal plate as needed to make sure the line is adequate. If the line is at a steep angle, you can turn the line-generating lens attached to the front of the laser to level it out.

**WARNING:** Never use the lasers without the line-generating lens as the laser is much more intense without it and can do damage if looked directly into.

Furthermore, if the laser line is fuzzy or seems “out of focus” you can tighten or loosen the line-generating lens to make the line sharper. After aligning the lasers properly, you should see a thin, clear red line of infrared light at the bottom of the wood block, just barely above the surface of the table.

**REMEMBER:** Only adjust one laser at a time for the safety of you and others. Only turn on the laser when you (and others) are standing out of the way and there is no chance that anybody will be looking directly at them. Safety first!

Now open CCV so you can check how well the lasers are adjusted. For best results, CCV should NOT capture and track your touch until you are actually touching the table (or at least very close to touching it). Your finger should be right at the surface before CCV “sees” it. If you are satisfied with your results, place the panel back on top and you are ready to go (remember to recalibrate CCV)!



# Other Maintenance

## *Projector:*

The projector's position and focus are very important to the accuracy of the game. If the position is incorrect, the angle that the image hits the mirror will be off and thus the image at the surface will not be aligned properly. It is also undesirable for the image to look fuzzy. The position of the projector relies on the straps that hold it to the wall as well as the legs underneath it. Adjusting these will allow you to properly position the projector should it ever need to be done. Adjusting the focus, however, can be a little tricky and requires some finesse. The projector's focus is maintained using a hook mechanism. The hook holds the lip of the projector lens in place and the hook's length is controlled by twisting a screw. To focus the projector, push the lens in with your hand and tighten the screw so that the hook holds it as far in as possible. Then, SLOWLY begin to loosen the screw, giving the hook more slack, so that the lens will fall slightly and rest on the hook. Do this very carefully until the lens is in the correct position to produce a clear image at the surface. Just keep in mind that adjusting the position and the focus of the projector requires some trial and error.

## *Mirror:*

The mirror's position in the table is also important for getting a properly aligned image at the surface. Both the vertical and horizontal angle of the mirror is controlled using another mechanism. For the vertical angle, the mirror rests on a mechanism that can raise or lower the mirror when a nut is tightened or loosened on a metal rod. To raise the mirror, lift the arm that the mirror rests on and slide the wooden stopper block beneath it forward. Then tighten the nut behind the block until the block rests on it. To lower the mirror, do the opposite. To adjust the horizontal angle of the mirror, there are two mechanisms, one under each side of the mirror. The mirror rests on wooden blocks on these mechanisms. The wooden blocks can be raised or lowered by loosening or tightening a nut underneath each block (similar to the arm the mirror is resting on). By raising one and lowering the other, the horizontal angle of the mirror can be changed. Adjust these mechanisms until you get the image on the surface where you would like it to be.

## *Camera:*

The camera must be positioned so that it can capture the entire surface of the table so that all touches on the surface are seen. The camera rests stably on the same arm as the mirror, but it may need to be realigned at some point. To do so, open CCV, place an object at each corner of the projected image (or have some friends place their fingers there) and adjust the camera's position so that CCV can capture all of these corner touches. Once the camera is in the correct position, stabilize it using something such as masking tape.

### *Surface:*

The surface of the table is made of two pieces of plexiglass (40" x 30") with a sheet of vellum in between. It is important to clean the surface of the table so that the image is clear. To clean the surface, use water with a cloth that will not cause scratches on the surface (such as microfiber cloths).

**WARNING:** Do NOT use Windex on the plexiglass as this may cause it to become foggy or cloudy.

To replace the vellum, unscrew the metal clips on the surface of the table (under the top panel) and remove the top piece of plexiglass. Be careful not to hit the laser mounts as this will knock them out of alignment. Then pull off the bottom piece and remove the vellum. Put the replacement vellum on the bottom piece and replace both pieces of plexiglass, as well as the metal clips holding them down.

**REMEMBER:** Before doing any work under the top panel, be sure to TURN OFF the lasers.

### *Lasers:*

The most common maintenance for the lasers is aligning them. However, should the lasers ever need to be replaced, you can order them from:

AixiZ Service & International, LLC  
1-888-4-AixiZ-1  
<http://aixiz.globat.com/>

The lasers used on the table are 780nm 25mW Laser Modules. You can also order 120 degree line-generating lenses if those need replacement. The lasers are easy enough to replace. Simply remove them from the mount and replace them with a new one. Be sure to realign the new one before use. Should the power source for the lasers need to be changed, each laser needs 3.2V to operate properly.

### *Intel Atom:*

If, for some reason, the OS on the Atom needs to be reinstalled, use 64-bit Linux Ubuntu and be sure to install the necessary drivers from <http://intellinuxgraphics.org/>. Also be sure to download and install Allegro 5 (the graphics library used to make the games) and Box2D (the physics engine used in Air Hockey). The png and audio development libraries also need to be downloaded to get Allegro to build. CCV can be downloaded from <http://ccv.nuigroup.com/>. Code::Blocks will also be necessary for running and/or modifying the TARGET software.

# Final Report for TARGET

---

## Appendix

# Final Report for Touch-Activated Response Gaming Entertainment Table (TARGET)

Patrick DeRoy (EE), Cory Gorman (CSE), and Marc Perras (CSE)  
 Department of Electrical and Computer Engineering  
 Senior Design Project 2011

**Abstract—** In the world of entertainment, anyone who has ever wanted a pool table, an air hockey table, or similar product has probably been deterred by the cost and difficulty associated with buying and installing one. These products can cost thousands of dollars and having several different game tables can take up a lot of space. For those wanting several game tables, there are existing multi-game systems that save space, but they can be just as costly and difficult to set up. We are proposing an alternative system that is not only cost effective and hassle-free, but also provides a fun and innovative way for gamers to play their favorite games. TARGET, which stands for Touch-Activated Response Gaming Entertainment Table, is an interactive touch screen game table that implements multiple game applications. For our prototype, our basic structure for the table was built from wood, PVC pipe, and an acrylic sheet, and the user touch was implemented by a method known as laser light plane (LLP) illumination, which will serve as the input to our system.

## I. INTRODUCTION

TOUCH-INTERACTIVE technology has become a very popular phenomenon used in today's society. Whether it is a cell phone, an iPod Touch, your local ATM machine, or computers at restaurants, more and more people are using this technology than ever before. It seems as though everyone wants to have the latest and greatest products that include a touch screen. We are seeing that it is becoming highly associated with entertainment. With this project, our team wants to provide an interactive gaming system that has a lower cost and a higher entertainment value than similar games already on the market. Currently, gaming systems can be very costly and sometimes difficult to install or maintain. This system would be a solution that is cost effective and hassle-free while still maximizing entertainment. Because of this, it would be a great product to have in many environments such as bars, arcades, or even at home.

There are some multi-touch systems that exist today, such as the Microsoft Surface. Such systems have a large touch screen that responds to user touch as input and can handle many users at once. This suits our needs very well, except for the cost; for example, the Microsoft Surface costs around \$12,500. Building a multi-touch system includes certain challenges. For our implementation, the table will consist of several main components: an acrylic panel used for touch input, a PlayStation 3 Eye camera, an Intel Atom processor, and a projector. The touch capability is accomplished using the laser light plane (LLP) illumination technique. Infrared light

from lasers is shined just above the surface. When the user's finger just touches the surface, the IR light will hit the tip of the finger and the PlayStation 3 Eye camera underneath the table will register this as a "blob". The camera captures an image of the user's touch (points of IR frustration) and sends the data to the Atom. The system takes this as input and determines the X and Y locations of the touch. It compares these coordinates to previous touches to determine if a move was made or a new touch has occurred. The newly updated graphics are processed and sent from the system to the projector for display at the user level.

## II. DESIGN

The system can be broken down into components for input, processing, and output.

The input to the system consists of user touches on an acrylic panel. In each corner of the panel, a laser module is placed. The laser module projects 780nm infrared light through a line-generating lens, effectively creating a plane of light above the surface of the acrylic. This laser light plane (for which the technique is named) is a mere millimeter above the surface. When an object, such as a finger, crosses the plane, the light is scattered, and some of it goes downward into the table. This is picked up by an infrared camera, and used as input to the system. Figure 1 below shows how LLP is implemented in our system.

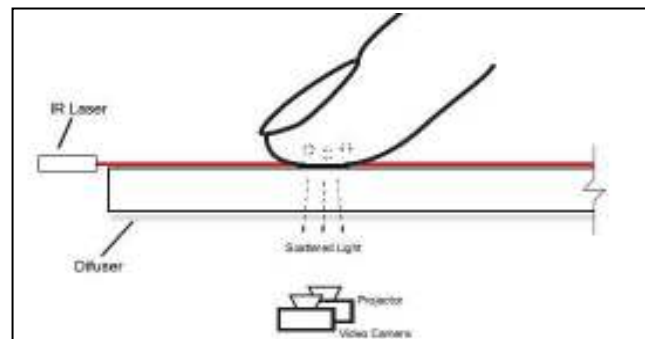

Figure 1. Illustration of laser light plane illumination.

The processing is handled by an Intel Atom unit. It processes the image it receives from the camera to find the locations of the users' touches in a coordinate space. These locations are then used by the applications, such as menus or games, as input to give the users control. The current

application state is updated and some graphics processing is performed.

The output image is then sent via VGA to a projector which lies under the table. The image is then projected onto the surface of the table for the users to see.

Figure 2 below shows the block diagram for our system and the following section describes it.

#### A. System Operation

In analyzing the block diagram, we will begin at the top. The user touches the panel, and in doing so crosses the laser light plane. The infrared light then travels down to the camera (bottom left), which sends its image data to the processing unit. The hardware of the processing unit is not very unique, so it will not be discussed in detail here. However, the software should be considered.

For image processing, the system must convert the image feed from the camera into user actions. Finger touches appear to the camera as light-colored “blobs” on a dark background. The image processing then determines the X and Y locations of these blobs, and also tracks them. It needs to determine which are new touches, which are fingers being dragged, and when the user has stopped touching. This information is then sent to the application software layer using a standardized protocol known as TUIO. TUIO utilizes UDP packets, so that communication between the image processing and application layers can be done with socket programming.

The applications consist mainly of menus and games. The menus provide a GUI through which the users can navigate the various games, their options, and table settings and configuration. The most common menu element is a button, which is considered “pressed” when the user touches it. The games interpret user touches differently depending on the

game. For example, in air hockey, the user controls his or her own paddle, which follows the movement of the touches. Other extraneous touches are disregarded by this game.

There is also a physics engine component, which a game may or may not use. For example, air hockey uses it for handling collisions between the game objects; a game like checkers would not use it. This engine simply needs to simulate a simple 2D environment and be able to handle things such as object motion, collisions between multiple objects, and friction.

The final software component is the graphics processing. This converts the current application or game state into an image so that the user can understand what is going on. When objects move, their positions on the screen should be changed, for example. The graphics component had to be capable of drawing simple shapes and text, and also of displaying images. It draws game objects as different “layers”; there is a background image, and some objects rest “on top” of others. However, it needs to output a flat screen image that the projector can display.

Not shown in the block diagram is the software that handles the sound. This could be considered to be in the same class as the graphics processing software. It simply plays a certain sound when a particular event happens. For example, when the air hockey puck collides with the wall, it plays a collision sound, as one would expect in real-life air hockey. This is sent through the sound card to the speakers.

The projector receives the image via VGA cable and displays it. The image is displayed on the same panel that the user touches. A sheet of vellum paper provides a surface where the image can form. In this way, the entire system is seen by the user as a touch surface device.

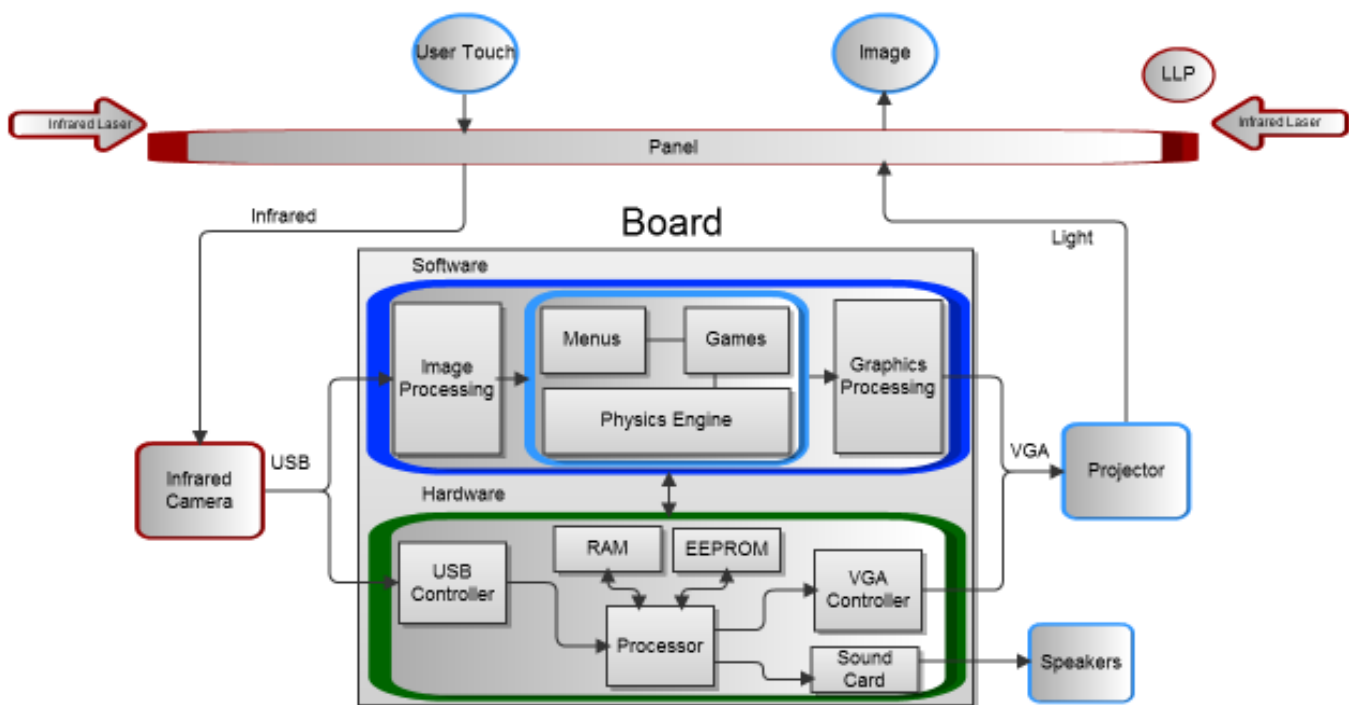

Figure 2: Block Diagram for TARGET

### III. DETAILED REQUIREMENTS SPECIFICATION

*A. The tracking software should be able to run at 60 frames per second or higher.*

If this capture rate is below 60 fps, then the delay can become too noticeable because it will take too long to get the touch data and process it in our software. Thus, the system must be able to receive image information from the camera, process the input, update the game state, and change the image on the screen in the smallest possible delay, preferably around 100ms as this is well under the time it takes for a user to react. This was easily tested using a latency test and we found that our delay was 64ms, which is acceptable. We will describe the experiment that tested this requirement later in the report.

*B. The height of the table should be between 3ft and 4.5ft.*

For the system to be usable, it must be at a comfortable height for people to play. This, of course, varies because the heights of people vary; however, we believe that this range represents the limits of comfortable playing heights for most people. However, for the shorter heights, it might require tall people to bend down; and for the taller heights, shorter people and children would likely need a stool. We have met this requirement with a table height of around 3.5ft.

*C. The size of the playable surface should be large enough to accommodate multiple players simultaneously*

The table is supposed to compete with other many-in-one game tables, as well as normal air hockey and pool tables. Thus, the surface of the table should be large to best simulate the games. The surface size of the table should be maximized and we believe that the current size of our surface (26"x35") is suitable.

*D. The system should be able to handle inputs from at least two players simultaneously without failing.*

Many games are played by two players, so the system should be able to handle at least that many. This means that it should be able to process at least 20 simultaneous inputs (ten fingers for each player). Of course, in most games, only a few touches need to be considered at once, and the extra touches should be ignored; however, this system must not produce an error nor considerably slow even if both players decide to use all their fingers at once. The number of touches that can be handled should be maximized.

The number of inputs the system can handle can be tested by increasing the number of touches present until an erroneous result occurs. We found that, at first, doing this did cause a failure, but we corrected the problem and now the table can handle up to 64 touches.

*E. The system should be usable in normal office-lighting conditions.*

For any game, it would be extremely frustrating to the players if the system did not respond to their inputs correctly. Not only should the response be timely, as mentioned previously, but it should be the response expected by the players. There are two factors to consider: the false positive rate and the responsiveness. False positives are caused by noise in the environment which makes the system believe a touch has occurred. The responsiveness can be measured as the number of actual touches to the number of touches the

system registers. Of course, the rate of false positives should be minimized and the responsiveness should be maximized. The false positive rate should be no higher than 0.01%, which at 60fps corresponds to roughly one false touch every 2.25 minutes. We feel that at this frequency, the false touches would likely not be too annoying to players. The responsiveness should be greater than 99%.

The performance of the system in this regard can be measured experimentally. To find the responsiveness, we count the number of actual touches and the number of touches registered by the system and compare them. This can vary between areas of the table, so the surface was divided into sections and the experiment performed multiple times. Then, the results were averaged, or the minimum result could be taken. To find false positives, the experiment was similar, except that registered touches which did not correspond to an actual touch would be counted.

In darkness, the noise from the environment should be low, so the false positive rate should be 0%. Also, the responsiveness should be close to 100%. The experiments were also performed in darkness to check that this is true.

We performed these experiments before MDR and again before FPR. The first time, our results did not meet these requirements, but after performing them again, we achieved the results we wanted and thus this requirement is satisfied. These results will be discussed later in the report.

*F. The projector must be bright enough to be visible in normal lighting without appearing too washed out.*

Of course, the amount of wash-out is difficult to quantify, so the experiment had to be based on our judgment. A test image was created which showed a range of colors, and this was projected in a lit room. If the image produced was unacceptable, then a more powerful projector would be needed. According to our research, a projector should output at least 1400 lumens, and preferably higher, for use in normal lighting conditions. The projector we settled on, which was generously lent to us by the ECE department, outputs at 2000 lumens. This will be sufficient in any lighting condition.

### IV. FINAL PROTOTYPE AND MEASUREMENT RESULTS

*A. Final Prototype*

In the CDR, our prototype consisted of the almost fully constructed table as well as a working software example that drew circles where the user touched. We still had some design hurdles to overcome such as obtaining a better response from our lasers for input, fixing the delay between input and output, and deciding on a final structure for the table itself. We also stated our goals for FPR. We said that by FPR, we would have liked to have the finished table and have developed software for the physics engine, UI, and game applications. At the bare minimum, we wanted to have at least one solid game working, namely air hockey. Since CDR, the software has been our main focus, as well as obtaining a high enough framerate from our tracking software such that the delay between input and output was acceptable. The projection

setup was still not 100% perfect either, but after a lot of experimentation and construction for stability, the projection setup is sufficient and as we desired with a focused image at the correct size and a stable mirror setup that will not move around if the table is bumped. To get the correct focus, we created a mechanism that serves as a fine adjustment for the lens. We were having trouble with this due to the fact that the projector is facing downwards and the lens naturally moves downwards because of gravity. Another issue we were having was a hot spot in the middle of our table from the projector which created a problem for input in the center of the table. Our solution was to place a piece of heat absorbing glass in front of the projector lens. Luckily this glass was pretty cheap and after creating a mount to hold it in place, we successfully minimized this hot spot dramatically. We bought stronger lasers and built new laser mounts to obtain a stronger input for the tracking software. Meanwhile, we worked on creating a prototype for air hockey that could be tested and debugged on our table. After making these adjustments and modifying the software for the game as desired, we have a prototype for air hockey that works quite well.

For software, we continue to use the CCV program for finger tracking, as it has proved more than sufficient. On the Atom, after updating graphics drivers and rebuilding the kernel, we are able to achieve a frame rate of around 100 fps. To create Air Hockey, we learned how to use the Allegro graphics library and the Box2D physics engine. We did this by making iteratively better demo applications in C++: first, a program which drew circles where the user touched; then one where the user could drag the circles; a non-interactive physics demo; a touch-interactive physics demo; an app with audio; an app with bitmap images; and then Air Hockey. We used an SVN to keep track of the different versions we had. A TUIO Listener waits for incoming TUIO packets, and when it receives one, it generates an event and places it in an event queue. In our main game loop, the system performs game logic, such as receiving and processing input, and then drawing. The inputs, along with framerate timer events, are processed one after another. The system then loops over all objects in the game and updates them. For the physics part of the game, when a touch occurs, a Box2D mouse joint is created, which forces an in-game object to move towards a point while still simulating correctly. The physics simulator then performs very precise collision detection and response for each object. When drawing, the main game loop calls each object to draw itself to a backbuffer. When all objects are finished drawing, the screen image is replaced with that of the backbuffer. All of this happens 60 times per second, and essentially this is how the Air Hockey game works.

In general, we are in a good place at this point in time. The expansion of more applications and games looks like it is right around the corner. As we said in the last report, part of designing a system such as this one is determining where design challenges exist and overcoming them. We believe we have overcome most of these challenges and come up with good solutions to stay on track. One of the keys to our success

was definitely the experiments we performed and the measurement data we obtained in these experiments. This is described, in detail, in the following section.

### B. Measurement Data

For our MDR prototype, we developed experiments to measure the responsiveness and the false positive rate of the touch surface. For both tests, we split the table surface into sections as shown in Figure 3. We performed each experiment in both light and dark environments to ensure that the touch surface works in any setting.

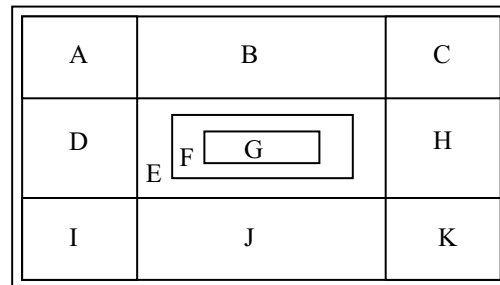

Figure 3: Touch surface test sections labeled A - K (Note: the lasers are mounted in the four corners of the surface)

For responsiveness testing, we tested each section of the table by touching it repeatedly a large number of times and keeping count of how many touches we performed and how many touches were registered by our system. To find responsiveness we use the following equation:

$$\text{Responsiveness} = \frac{\text{number of registered touches}}{\text{number of actual touches}} \quad (1)$$

While testing responsiveness, we simultaneously tested for false positives. We kept track of the number of false touches that were registered by the software during the responsiveness test. To find the false positive percentage we use the following equation:

$$\text{False Positive} = \frac{\text{number of false positives}}{\text{number of actual touches}} \quad (2)$$

We expected that the sections on the sides of the table (B, D, H, J) would have the least responsiveness as they are not receiving as much IR light. The sections near the lasers (A, C, I, K) would likely have high responsiveness, as they are closest to the lasers and have high IR exposure. Similarly, the middle sections (E, F, G) would likely have high responsiveness, as this is where the IR light from each of the four lasers meets. These results also differ in the two different settings (light and dark) because in a light environment, the touches could be washed out by ambient lighting, and in a dark environment, there is a much higher contrast between touches and the background. The goal is to maximize responsiveness in any setting.

We expected that the false positive test would rely highly upon the setting. For example, in a setting with a lot of ambient lighting, we would expect more false positives, as there can be IR light in the surrounding environment. And of course in a setting with little or no ambient lighting, we would expect very few false positives. Clearly we want to minimize this factor in any setting.

Table 1(a) shows our results for the responsiveness test and Table 1(b) shows the results of our false positive test when we performed these experiments for MDR. Recall from our requirements section that our goals were to have 99% responsiveness and a false positive rate of one per 5.5 minutes (0.01%). You can see from these results that we were not quite meeting our requirements yet.

Responsiveness (%)		
Region	Dark Setting	Light Setting
A	100	100
B	100	100
C	100	94
D	76	70
E	92	90
F	92	94
G	96	88
H	100	100
I	94	92
J	100	90
K	100	92

Table 1(a). Results of the initial responsiveness test.

Number of False Positives		
Region	Dark Setting	Light Setting
A	0	0
B	0	0
C	0	0
D	0	2
E	0	0
F	0	0
G	0	0
H	0	0
I	0	0
J	0	0
K	0	0

Table 1(b). Results of the initial false positive test. (Note: 2 false positives in D account for 0.36%)

Our overall results for this experiment were as follows: responsiveness was at 91.82% in a light setting and 95.45% in a dark setting; false positive percentage was 0.36% in a light setting and 0% in a dark setting. Since our results in this experiment were not up to our requirements, we needed to adjust to make them so. First, we were able to focus the lasers to make them stronger, so we could adjust them to focus more light in the areas that require it. Also, we tried to focus the

camera better so that it was more likely to capture touches. We could also adjust the settings on our tracking software. If necessary, we could have switched to 850nm lasers, as they are unlikely to be more susceptible to noise from ambient lighting (although they are more expensive), or switch to higher power lasers (although they are potentially more dangerous). We also have to note that there are many external factors that affect this experiment and we had to try to minimize this as much as possible.

For our final design, we made adjustments and performed these experiments again. Before performing this experiment for the FPR, we had replaced the lasers with higher power ones (25 mW). After adjusting them such that the table coverage was ideal, focusing the camera to its best potential, and making sure CCV picks up finger touches accurately, we obtained much better results. Tables 2(a) and 2(b) show that when touching the table rapidly 50 times in each section, whether it was light or dark, we obtained 100% responsiveness and 0 false positives. These results certainly do meet our requirements!

Responsiveness (%)		
Region	Dark Setting	Light Setting
A	100	100
B	100	100
C	100	100
D	100	100
E	100	100
F	100	100
G	100	100
H	100	100
I	100	100
J	100	100
K	100	100

Table 2(a). Results of the final responsiveness test.

Number of False Positives		
Region	Dark Setting	Light Setting
A	0	0
B	0	0
C	0	0
D	0	0
E	0	0
F	0	0
G	0	0
H	0	0
I	0	0
J	0	0
K	0	0

Table 2(b). Results of the final false positive test.

Another important experiment we performed was to measure the input latency of our system. As we began writing the software for our table, we noticed that there was a noticeable delay between the input and the output that was



unacceptable as it made gameplay seem unrealistic. We did not even need to measure this delay because it was bad enough that we could see it with our own eyes. We made several adjustments to reduce this delay, such as reducing the resolution, adding touch prediction, and switching from a 32-bit operating system to a 64-bit operating system. After doing so, the delay was dramatically reduced and was almost too short to notice. Although this is what we wanted, we still decided to design an experiment to see just how long this delay was. This experiment involved an additional laser and an additional Playstation 3 Eye camera. Basically, we would shine the laser on the table to get a response from the game and capture this using the high-speed camera. Then we would look at the captured video and step through it frame by frame. Once the laser turned on, we counted the number of frames it took for the object on the table to reach the “touch” created by the laser. By doing so, we could divide this number by the framerate of the camera (125 fps) to get the delay from input to output. We performed this experiment with CCV, our tracking software, capturing touches at 20 fps, 30 fps, 75 fps and 100 fps. The results from this experiment can be seen in Figure 4 below.

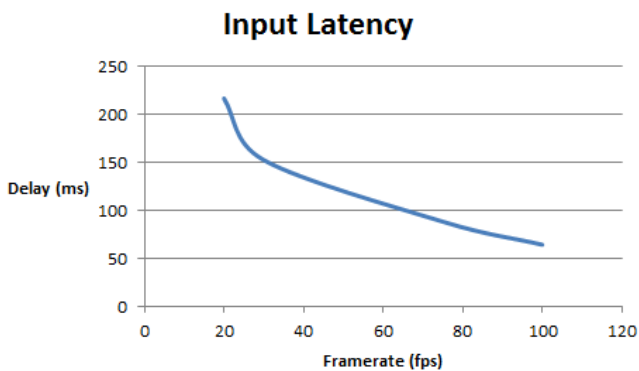

Figure 4: Results of the input latency experiment.

As you can see from the results above, we found the delay got smaller as CCV’s capturing rate grew larger. By running CCV at 100 fps, the delay is about 64ms. This is an acceptable delay because it will not affect the user’s gaming experience.

## V. PROJECT MANAGEMENT

### A. Team Roles

Our first step in beginning this project was visualizing the table that we wanted. We all collaborated and came up with our initial ideas for construction of the table. To visualize this design, we used Google SketchUp to create a CAD layout of our table. The building of the table itself was a team effort where we all took part in building the frame for the acrylic sheet, assembling the frame and legs, assembling crossbars for stability, etc. There were a lot of tasks that needed to be done to test our ideas, which included modifying and testing the PS3 Eye camera (changing the filter), testing the lasers with the

camera, prototyping laser mounts and crossbars, experimenting with the projector and mirrors. We all took part in these experiments and helped one another. It was not until we moved on to other areas of the project that we established and set concrete team roles. These team roles are:

- Patrick DeRoy: Projection setup for output, physics engine, GUI, incorporating image bitmaps into games
- Cory Gorman: Laser & camera setup for input, game development, incorporating touch prediction, website administrator
- Marc Perras: Table structure and design, image and graphics processing, incorporating audio into games

We set these team roles to assign one person to each area that we worked on together to ensure that someone is responsible in making sure that portion of the project is maintained and functions correctly. In the first semester, the actual building of the table was our main focus, a task which is sequential and involved more than one person at a time to work on. Although we still had structural requirements to finalize, the second semester’s main focus was the software portion of the project. Even though we could have worked on all of the software together, it was easier to divide this portion of the project into sections and to assign one another to specific areas and specific aspects of the games. By doing this, we could work on the software in parallel and get a fully functioning game in a short time. Thanks to our hard work, research, help from forums online, input from our advisor, and the experiments we performed, we now have a better understanding of how the software works together and achieved success in creating an output at the user level that is fun and realistic.

## VI. APPENDIX

### A. Application of Mathematics, Science, and Engineering

In the design and development of this prototype, we have used the knowledge and skills acquired in the following courses:

#### 1. ECE 242: Data Structures & Algorithms

We must create efficient software by using data structures and various algorithms for both the image processing and graphics processing in our system, as well as object-oriented techniques for games.

#### 2. ECE 354: Computer Systems Lab II

We use the concepts of embedded system software development and image processing from this course in our system design to process image data for both input and output on the Intel Atom and interfacing with external devices.

#### 3. ECE 374: Computer Networks & the Internet

From this course, we are able to use our knowledge of socket programming, which we use for interprocess communication between the image processor and applications.

#### 4. *Physics 261: General Physics III*

In the implementation of our design, we use the concepts of waves and optics including reflection for the projection as well as the reaction of infrared light to interference.

##### *Detailed Example:*

We used concepts from physics that allowed us to determine the proper positioning of our projector and mirror in order to provide a clear and properly sized image at the surface of the table. To do so, we used ray tracing to help determine the angle of the projector and the mirror as well as the distance required between the projector, the mirror, and the surface. When reflecting the projected image off of a mirror, we had to figure out how to avoid problems with the physics of this reflection, such as keystone correction (image skewing caused by reflection). Additionally, we used our knowledge of infrared light for our touch surface. The objective of the lasers is to serve as an indicator of when and where the surface is being touched so that our software can determine when and how to react. For this to work, the infrared light needs to bend downward upon encountering interference. That is, when a person touches the table, and thus interfering with the IR light, we need the IR light coming from the lasers to be deflected downward so that the IR camera underneath can pick up the light.

#### *B. Design and Performance of Experiments, Data Analysis and Interpretation*

We decided that one of the most important aspects at MDR was ensuring that we had the appropriate “strength” of input. That is, we want the finger touches to be as bright as possible so that our software will be able to pick them up as easily and accurately as possible. This also requires that all locations of the surface (corners, middle, sides, etc.) have an acceptable brightness for finger touches. Since we are engineers, we had to devise an experiment that would allow us to determine whether this was the case. Our experiment involved dividing the table surface into sections and then testing each section using our software. Basically, we would repeatedly touch the section of the table we are testing to see how accurately the software could pick up the touch. We were looking to see if the number of touches was correct because we could have missed touches or false touches. This would tell us whether we needed stronger lasers, or whether there was enough difference in the brightness of touches versus ambient light, or if there were any dark spots (locations on the table that were out of reach of the touch effect). We found that we needed brighter lasers because the finger touches were not as bright as we would like them. After purchasing new lasers, which were 25 mW instead of 10 mW, we obtained much brighter results from the touches. We performed this experiment again before FPR, and found our results to be much better.

Another aspect we needed to test was the input latency from the moment a finger touches the table to the time the game reacts to that touch. To test this, we used a second high-speed camera to capture a laser positioned above the table. The

camera captured the laser turning on and the game reacting to the laser’s “touch.” We then looked at the video captured by the camera and counted the number of frames it took for the game to react. We then divided the number of frames by the camera’s framerate (125 fps) to get the delay. With CCV running at 100 fps, we were getting an input latency of 64ms. We deemed that this was acceptable as it does not cause an unrealistic lag.

#### *C. Design of System, Component or Process to Meet Desired Needs within Realistic Constraints*

The various requirements for our design pertain to system performance and physical constraints of the table itself. With regard to performance, the system needs to handle inputs from multiple users and it needs to be able to process finger locations and produce an output in the smallest amount of time needed to simulate a real game. It also has to include a realistic physics engine so that the response in each game is comparable to a real game. With regard to physical constraints, we wanted the table to be large enough to feel like a table game already found in homes and public locations, but we did not want the table to be unrealistically tall due to our projection setup.

There are also several real-world constraints for our design. First, we have an economic constraint in the cost of the project. Ideally, we would want to market the table as a product for consumers. If this is the case, we need to ensure that the design cost does not exceed that of competitors already on the market. Secondly, there is a social constraint of usability. We want our table to be easy to use for all age groups. This means simplicity at the user level and this is also affected by our physical constraint since we would want people of all heights to use the table. Lastly, we have a health and safety constraint. The lasers we are using, although low in power, could be potentially dangerous if there is direct eye contact.

Currently our design meets several of the constraints above, or it at least allows us to adjust in order to adhere to these constraints. For performance, we have successfully captured touches from multiple users by using multiple lasers on the table, which eliminates occlusion (blockage of finger touches by other interferences on the table). Additionally, we have tested our table to make sure that the time it takes for a touch to cause a reaction is minimized. Our test showed that the delay was small enough (64ms) that there was minimal lag during gameplay. To address the physical constraints, we have made our table adjustable in height so that we can experiment with the projection to avoid making the table too tall. After several adjustments to make the table short enough, we were able to get the table’s height down to about 3.5 feet.

For the economic constraints, we remained under budget due to the fact that we were able to get a lot of materials for free. However, we must determine how much it would cost to produce as a commercial product. With our prototype, we have found several ways we can decrease cost if necessary, such as building our own projector instead of buying one and modifying the Playstation 3 Eye camera for IR instead of buying an IR camera. Although we were able to stay under the

budget limit of \$500, we estimate that the production cost of our table would be around \$850 - \$900. This may seem high, but it is still a relatively good cost compared to games that this project could compete with. The social constraint is also addressed by the adjustable height of the table. When creating the user level software, we intended to make it very simple. Essentially, there is a menu of buttons for selecting a game (just push and play). For health and safety concerns with our lasers, we intended to make the table short enough so that the lasers are not at the level of the eyes of the users and we will include warning labels. Additionally, for our safety in development, we included switches which allowed us to turn off the lasers we are not working on, so we do not mistakenly look into them. On the top of the table there is a frame which covers the lasers and the switches to ensure that the users will not be able to see anything but the playing surface. This will ensure that they are not look at the lasers directly and that they will not accidentally hit the switches.

*D. Multi-disciplinary Team Functions*

- Patrick DeRoy, EE: In charge of projection setup for output, physics engine, GUI
- Cory Gorman, CSE: In charge of laser and camera setup for input, game development, website administrator
- Marc Perras, CSE: In charge of table structure and design, image and graphics processing

*E. Identification, Formulation and Solution of Engineering Problems*

One issue we had with the system was that when a user dragged their finger, the table’s touch response would lag behind. The motion was correct, but it was just a bit too late.

Earlier in the paper we talked about input latency, and how we were able to achieve a latency of 64ms--much lower than the average human reaction time of around 215ms. Therefore, when a user places their finger on the table, the response seems instantaneous. However, when dragging their finger, reaction time does not matter anymore because the user can see clearly that the position of their finger and the table’s response is not the same.

So despite our extremely low input response time, this made our table seem sluggish. And when playing air hockey, although still quite enjoyable, the lag made the game seem unrealistic. Furthermore, it would be impossible to reduce the input latency all the way to zero, so bettering our response time would not help the situation.

Figure 5 shows how the delay affects response time of the table. The table response is always behind the user’s touch by 1 latency unit.

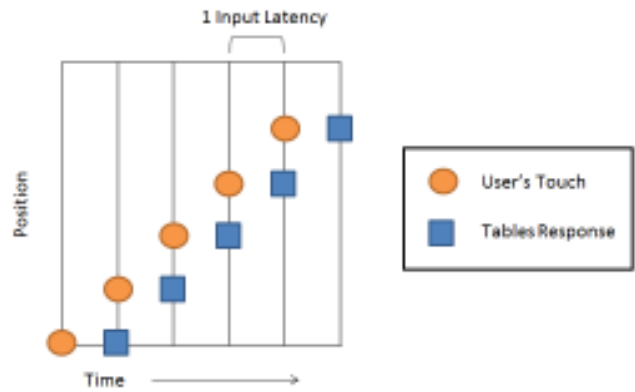

Figure 5: The effect of input latency on the table’s response

However, we realized that users’ input to air hockey is actually quite predictable. Typically, a user will be holding the paddle still, then move very rapidly in a rather straight line, and then slow to a stop again or changing direction. Thus, we developed a system for Touch Prediction.

As can be seen in Figure 5 below, we can extrapolate based on the previous touch’s velocity to find a new position and “catch up.” There will be some overshoot (or in the case of speeding up, undershoot), but we can also look at the change in velocity to try to account for this and minimize the amount of time we are “wrong.”

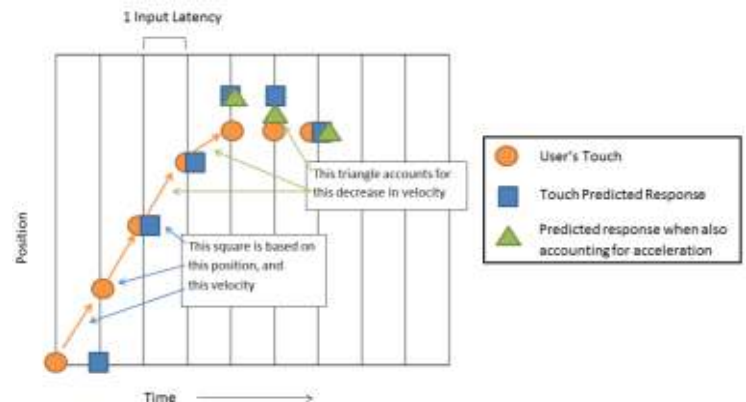

Figure 6: Using touch prediction to eliminate the lag between the user touch and the table’s response.

Essentially, we are predicting where the user’s touch will be based on the current velocity and position. By doing so, we can update the graphics with predicted information, eliminating the lag that would normally exist. To implement this, we created the following equation:

$$\text{Predicted Position} = \text{Touch Position} + \alpha * \text{Delay} * \text{Velocity} + \beta * \text{Delay} * \left( \frac{\text{Velocity}}{\text{Velocity}_{old}} - 1 \right) \tag{3}$$

where Delay is our input latency and  $\alpha$  and  $\beta$  are parameters to be set after experimenting. This equation is applied on both the x- and y- axis.

We have found that, in practice, this works really well, even for curves or other more “unusual” motions. It is difficult to

design an experiment to back up this statement, but we found that when using the table, the table's response is much closer to the user's finger, and very often directly beneath it. We invited some other students to test the response for Air Hockey, and they seemed satisfied with the Touch Prediction's response. Also, the reason for this working so well can be determined from looking at the above figures. At first, it would seem that it would not work well, because it looks like we are still wrong half of the time. However, most of the motion consists of the "middle part" where the prediction is correct. Also, remember that these times are extremely small--only 64ms--so any overshoot seems much less noticeable, and the acceleration factor helps with that as well. Thus, we are very satisfied with the Touch Prediction solution to the dragging lagging problem and believe it will provide for a much better user experience.

#### *F. Understanding of Professional and Ethical Responsibility*

One issue with ethical responsibility is the safety of our laser setup. We have to be sure that the lasers will not affect the health of the user. We can do so by switching them off as we work on them and placing them in a safe location within the table so as to avoid eye contact from the user. Additionally, we can display a warning so that the users will know the lasers could potentially be harmful. Our final prototype includes wood that covers up the lasers to prevent the user from looking directly at them.

An issue of professional responsibility is for us to give credit to those who have created software that we are using in our project. One in particular is the software, called Community Core Vision (CCV), for tracking finger touches. It is our professional responsibility to give credit to its developers. We also must give credit to Erin Catto, creator of the Box 2D Physics Engine. The contribution of this software made game development much easier. Finally, we would like to acknowledge the developers of Allegro, the graphics library we used for our games.

Additionally, we would like to thank Professors Russell Tessier, Tilman Wolf, Dennis Goeckel, Ramki Gummadi, T. Baird Soules, and especially our advisor Paul Siqueira. We would also like to thank Unistress Corporation and Petricca Industries, as well as the ECE department for donations to this project. A great deal of thanks to Francis Caron and Rich Correia for helping in the SDP lab all year.

#### *G. Team Communication*

Team communication has been primarily done through weekly meetings, both with the team and our advisor. The team meets about three to four times a week, generally Monday through Thursday. Our team meeting with our advisor generally takes place on Wednesdays at 10 am or 11am. In all of these meetings, we discussed our progress and collaborated on design issues. Our advisor gave us feedback on our progress, made suggestions for what we should accomplish for our next meeting, and provided us with information that was useful for our design reviews.

Outside of the team meetings, we also communicated via email and phone. We used an SVN for our software as a

means of communicating our work to other group members. Additionally, we kept lab journals that contain information on what we had done, ideas for what we would do in the future, and simple notes or to-do items to keep us on track.

Marc Perras was the main contact for the team for setting up advisor meetings and design reviews with the team's evaluation board.

#### *H. Understanding of the Impact of Engineering Solutions in a Global, Economic, Environmental, and Societal Context*

This project can have an impact both in an economic and societal context. Economically, it could potentially stimulate the market for gaming and entertainment. Currently, there are no inexpensive touch surfaces on the market and so the competitors in this area have been traditional game tables. If this product were introduced to the gaming and entertainment market, it could become a competitor because it is relatively inexpensive and the idea of touch technology in a gaming table would be very popular. Gaming systems are always trying to find new ways for the user to interact with the game and we believe that this project will do just that. This is where societal impacts come into play as well. If we were to market our design as a product, people would buy our table for their homes or their businesses (such as bars or arcades) where people go to be entertained and enjoy the company of others. Our table could provide a reason for friends and family to interact more often and bond with each other.

#### *I. Application of Material Acquired Outside of Coursework*

The following are examples of sources of material outside of our coursework:

1. *NUI Group: A public forum for people interested in computer vision and natural user interfaces, including multitouch technologies.*
2. *Community Core Vision (CCV): Open source software for object tracking.*
3. *Manuals and other documentation for the Intel Atom embedded computing platform.*
4. *Box 2D Physics Engine: Open source physics engine written primarily for games.*
5. *Allegro: An open source graphics library.*

#### *Detailed Example:*

We are using the CCV software to track finger touch locations for our system input. The software is open source and so we can modify and rebuild it if necessary. The software allows us to filter and amplify finger touches so that they can be easily tracked. We not only used this for our tracking software on the finished table, but also for testing during development.

To learn how to use graphics library and physics engine, we read the manuals for them and learned from the included examples. We also analyzed some of the source code for these to find out information that the manual did not include--for example, the usage of mouse joints in Box2D and the way Allegro handles audio drivers on Linux.

### J. Knowledge of Contemporary Issues

There are several issues we wanted to solve by designing this system. First, we wanted to create a solution to the problems that arise with traditional game tables as well as existing multigame systems. These systems can be costly and inconvenient. In addition to solving these problems, we believe that this table would also be very popular and on par with current technologies. For example, touch interfaces have been very popular in many devices, such as smart phones, mp3 players, and computers. Because this has been a popular reason to purchase these items, we feel that the same demographic will take an interest in our table. Taking these contemporary considerations into account, we believe that we have a reasonable motivation for this design.

### K. Use of Modern Engineering Techniques and Tools

Three modern engineering techniques and/or tools that we are using for this project include:

1. *Object-oriented programming and socket programming using C++ for our game development and data processing.*
2. *Laser Light Plane touch technology, which is a well-known technique in the NUI community.*
3. *Versioning tools such as Tortoise SVN and Springloops for software development.*

#### Detailed Example:

The NUI community is devoted to finding new ways of creating natural interfaces, such as Laser Light Plane. This technique is widely known by them to be very effective for touch applications. This is a modern technique developed by professionals with degrees in Computer Science and Engineering.

### REFERENCES

- [1] NUI Group Community. (2008, May 22). *Getting Started with Multitouch: Multitouch Techniques*. [Online]. Available: <http://nuigroup.com/forums/viewthread/1982>
- [2] NUI Group Community. (2009, November 5). *Laser Light Plane Illumination (LLP)*. [Online]. Available: [http://wiki.nuigroup.com/Laser\\_Light\\_Plane\\_Illumination\\_\(LLP\)](http://wiki.nuigroup.com/Laser_Light_Plane_Illumination_(LLP))
- [3] NUI Group Community. 2010. *Community Core Vision*. [Online]. Available: <http://ccv.nuigroup.com/>
- [4] Code Laboratories. 2010. *PS3Eye Disassembly & IR Filter*. [Online.] Available: <http://codelaboratories.com/research/view/ps3-eye-disassembly>
- [5] Projector People. 2010. *Lumens Guide*. [Online.] Available: <http://www.projectorpeople.com/resources/lumen-guide.asp>
- [6] ADTECH Systems and The Projector Pros. 2011. *Throw Ratios and Viewing Distances*. [Online]. Available: [http://www.theprojectorpros.com/learn-s-learn-p-theater\\_throw\\_ratios.htm](http://www.theprojectorpros.com/learn-s-learn-p-theater_throw_ratios.htm)
- [7] Da-Lite. 2011. *Angles of View: Projection Geometry*. [Online]. Available: [http://www.da-lite.com/education/angles\\_of\\_view.php?action=details&issueid=28](http://www.da-lite.com/education/angles_of_view.php?action=details&issueid=28)
- [8] Mitsubishi Electric Corporation. 2011. *XD200U DATA Projector User Manual*.
- [9] Box 2D Physics Engine, 2010. *Box2D v2.1.0 User Manual*. [Online]. Available: <http://www.box2d.org/manual.html>
- [10] Allegro, 2010. *Allegro 5 Reference Manual*. Available: <http://www.allegro.cc/manual/5/>
- [11] Allegro Wiki, 2010. *Getting Started With Allegro: Allegro 5 Tutorial*. Available: [http://wiki.allegro.cc/index.php?title=Allegro\\_5\\_Tutorial](http://wiki.allegro.cc/index.php?title=Allegro_5_Tutorial)