

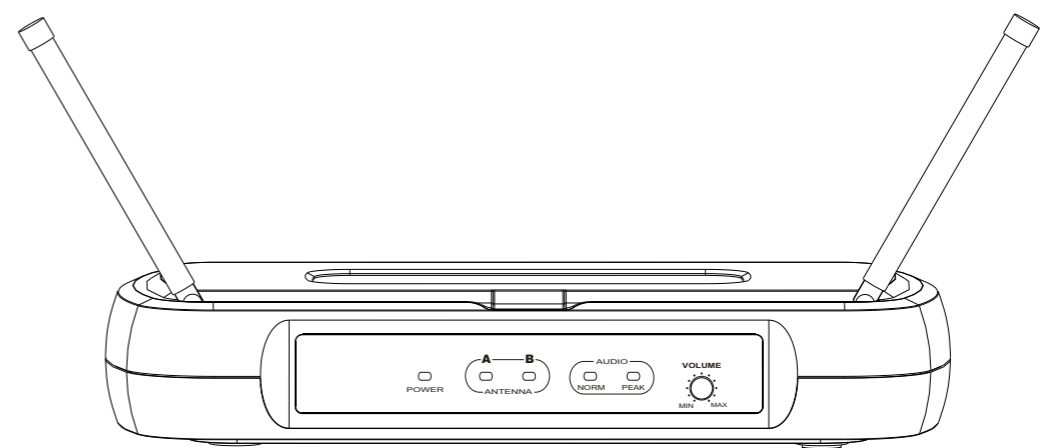

User Manual



MC Crypt Free1 UHF Wireless Series 863-865MHz*

*Bitte informieren Sie sich bei Ihrer lokalen Telekommunikationsbehörde.
*Please inform your local Market Surveillance Authorities for Telecommunications.



Printed in CHINA

System Components

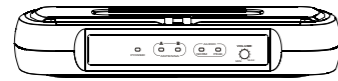

All systems include:
Free1 receiver
2 "AA" batteries
A 1/4" RF connector
Power supply
User guide

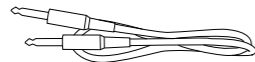

Vocalist system includes:
Free1 handheld transmitter

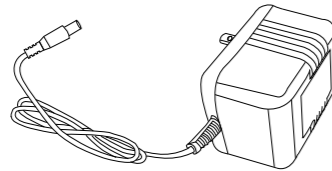

Headset system includes:
Free1 bodypack transmitter
Microphone (choice of PL-10 or PL-20 lavalier, PH-10 or PH-20 headworn)

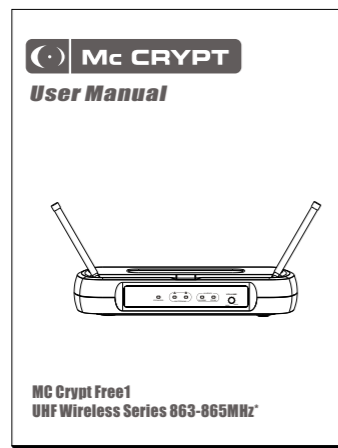
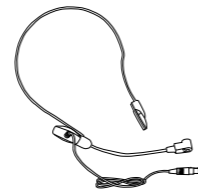
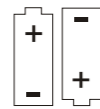

Guitar system includes
Free1 bodypack transmitter
1/4" to mini 3-pin guitar cable



Free1 Receiver Features

Front Panel

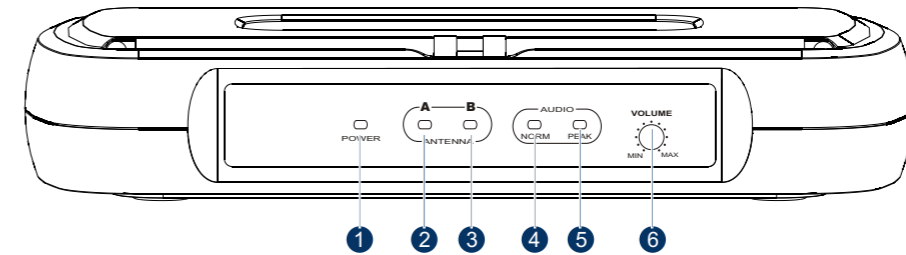

- | | |
|---|--|
| 1 Power indicator | 4 Audio level indicator |
| 2 Channel A antenna LED lamp
When it is steadily lit, Channel A antenna is working | 5 Audio level peak indicator |
| 3 Channel B antenna LED lamp
When it is steadily lit, Channel B antenna is working | 6 Audio output level control
Left turn for output level decrease, right turn for output level increase. |

Rear Panel

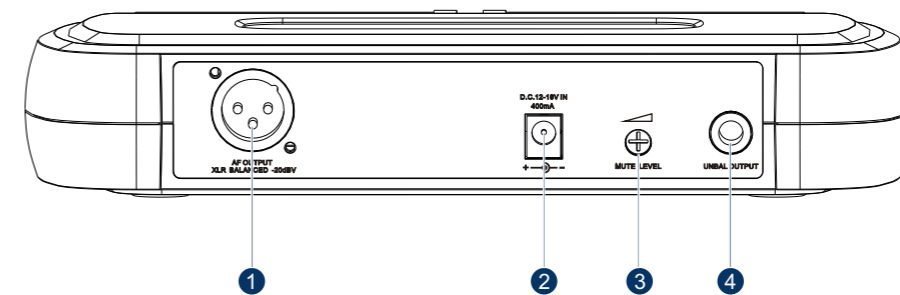

- | | |
|---------------------|--|
| 1 XLR output jack | 3 Fine adjustment of mute threshold level
This is the mute enabling threshold value, which is set to factory default and there is usually no need to adjust it, if there are any interference signals, this threshold value can be increased by turning the knob clockwise until RF signal lamp goes out. |
| 2 AC adapter jack | |
| 4 Unbalanced Output | |

Handheld Transmitter :

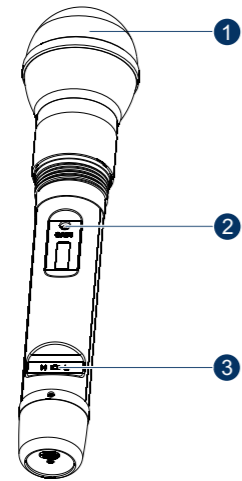

Functions:

- ① Microphone head
- ② Adjust input sensitivity of the microphone head
Left turn for sensitivity decrease, right turn for sensitivity increase.
- ③ RF power switch
H for high power and L for low power
- ④ Battery compartment
- ⑤ Power/ASC/Battery low indicator light.
Green on: power on
Green flash: IR transmission in process.
Red flash: battery low
- ⑥ On-off/mute switch

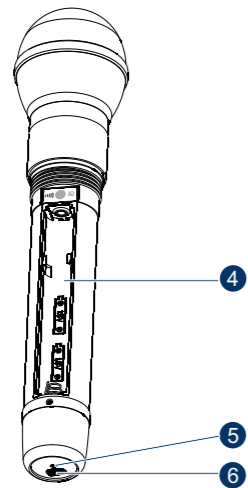

Changing Batteries:

Expected life for two alkaline batteries is up to 10 hours. When turned on, the Battery indicator flashes red and goes off again. If the battery indicator constantly lights up red, the batteries should be changed immediately (as shown below).

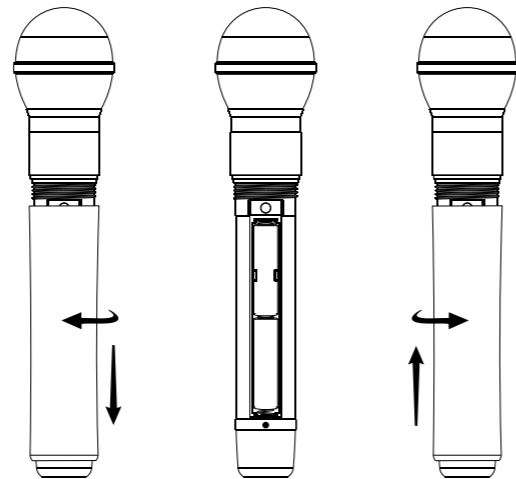

Free1 Bodypack Transmitter

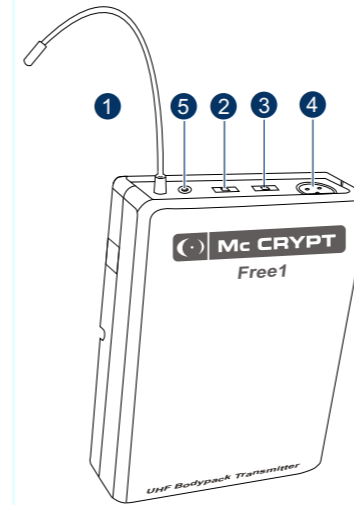

Features :

- ① Antenna
- ② On/Off switch, when it is in middle position, mute.
Two gain settings are available on Free1 Bodypack choose the appropriate setting for your instrument
Mic: microphone
0: Guitar with passive pickups
-10dB: Guitar with active pickups
- ③ Gain adjustment switch and mute indicator
- ④ 3-pin Microphone Input Jack
- ⑤ Power/Low indicator light
When turned on, the Battery indicator flashes red and goes off again. If the battery indicator constantly lights up red, the batteries should be changed immediately

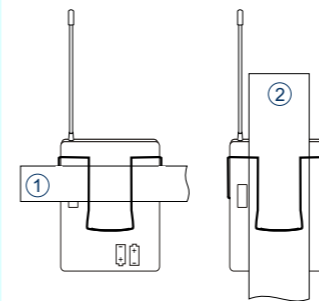

Wearing the Backpack Transmitter:

Clip the transmitter to belt ①, or slide a guitar strap through the transmitter clip ②, as shown. For best results, slide the transmitter until the belt ① is pressed against the base for the clip.

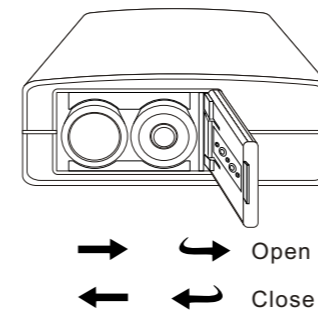

Changing batteries:

Expected life for Two Alkaline batteries is approximately 8 hours. When the transmitter light glows red, the batteries should be changed immediately, as shown on the left.

Trips for improving System Performance

- Maintain a line of sight between transmitter and antenna.
- Avoid placing the receiver near metal surfaces or any digital equipment (CD players, computes, etc)
- Keep the receiver away from the wall and over 1m to the ground
- Cellular telephones and two-way radio and so on can interfering the transmitting frequencies, maintain a distance from the interfering equipments or any cause interfering.

Troubles Shooting

Issue	Indicator Status	Solution
No sound or faint sound	Transmitter ON Indicator stop flashing	Turn on transmitter Make sure the +/- indicator on battery match the transmitter terminals
	Power indicator off	Make sure AC adapter is securely plugged into electrical outlet and into DC input connector on rear panel of receiver.
	Receiver RF indicator glows	Turn the receiver up Turn up the Gain adjustment switch in the transmitter Check the power connection of the receiver and amplifier or mixer
	Receiver RF indicator off, transmitter indicator ON	Take the receiver away from the metal objects Check whether there is hamper between receiver and transmitter Move the transmitter near the receiver Check the receiver and transmitter whether use the same frequency
	Transmitter low battery indicator ON	Change the batteries in transmitter
Distortion or unwanted noise bursts	Receiver RF indicator ON	Remove nearby sources of RF interference(CD players, computers , digital effects ,in-ear monitor systems, etc.)
Distortion level increases gradually	Transmitter low battery indicator ON	Change the batteries in transmitter
Sound level different from cabled guitar or microphone, or when using different guitars		Adjust transmitter again and receiver volume as necessary

Specifications

System

Frequency Range and Transmitter Output level

Band	Range	Transmitter RF level
UE	838-865 MHz*	10dBm

Operating Range under Typical Condition
50m (150 ft.)

Note: actual range depends on RF signals absorption, reflection, and interference.

Audio Frequency Response (+/-3 dB)

60Hz ~ 16KHz

Total Harmonic Distortion

(+/- 30 KHz deviation, 1 KHz tone)

<1%

Dynamic Range

> 90 dB (A-weighted)

Operating Temperature Range

-10 C to +50 C

Note: battery characteristics may limit the range

Bodypack Transmitter

Audio Input Level Maximum

0 dBV ~+20 dBV

Gain adjustment Range

30 dB

Input Impedance

470 kilohm

85mm H × 65mm W × 23mm D

Weight

80 grams without batteries

Power Requirement

Two "AA" size alkaline or rechargeable batteries

Battery life

> 8 hours (Alkaline)

Handheld Transmitter

Audio Input Level maximum

0 dBV

Dimensions (including the microphone)

250mm × 53mm Diameter

Weight

270 grams

Battery Requirements

2 "AA" alkaline batteries or rechargeable batteries

Battery Life

> 10 hours (Alkaline)

Receiver

Audio Output Level Maximum (ref. +/-30 KHz, 1 KHz)

XLR connector (into 600Ω load): -12 dBV

1/4inch connector (into 3000Ω load): -18 dBV

Output Impedance

XLRconnector 200ohm

1/4inch connector 1kilohm

XLR Output

Impedance balanced

Pin 1: Ground

Pin 2: (+)

Pin 3: (-)

Sensitivity (intermediate frequency adjustment

audio noise output <-92 dB)

Image Rejection

> 90 dB

Dimensions

235mm H × 118mm W × 44mm D

Weight

370 grams

Power Requirements

12-18 Vdc at 400 mA , supplied by external power supply

*** One fixed frequency within 863-865 MHz.**

Available frequencies:

863.100 MHz | 863.900 MHz | 864.500 MHz

864.900 MHz



Recycling (Batteries or rechargeable batteries)

The supplied batteries or rechargeable batteries can be recycled. Please dispose of them as special waste or return them to your specialist dealer. In order to protect the environment, only dispose exhausted batteries. Together for a good nature.



Correct Disposal of This Product (Waste Electrical & Electronic Equipment)

(Applicable in the European Union and other European countries with separate collection systems)

This marking shown on the product or its literature, indicates that it should not be Disposed with other household wastes at the end of its working life. To prevent possible harm to the environment or human health from uncontrolled waste disposal, please Separate this from other types of wastes and recycle it responsibly to promote the sustainable reuse of material resources.

Household users should contact either the retailer where they purchased this product, or their local government office, for details of where and how they can take this item for environmentally safe recycling.

Business users should contact their supplier and check the terms and conditions of the purchase contract. This product should not be mixed with other commercial wastes for disposal.

Safety instructions

No user serviceable parts inside! Never open the transmitter, otherwise you can receive an electric shock. If units are opened by customers in breach of this instruction, the warranty Becomes null and void.

Use the transmitter in dry rooms only. Never expose it to water (eg: never place it in a position where it could be subjected to water splashes). Do not place any objects containing liquids on the top of the unit.

Keep the transmitter away from direct sunlight, central heating radiators, electric heaters and similar sources of heat. Ensure sufficient ventilation, especially when it is mounted into a 19" rack.

Use a damp cloth for cleaning the unit. Do not use any cleansing agents or solvents.

Attention! High Volume!

This is a professional transmission system. Commercial use is subject to the rules and regulations of the trade association responsible. Adam Hall, as the manufacturer, is therefore obliged to expressly point out our possible health risks arising from use.

This system is capable of producing sound pressure exceeding 85 dB (A). 85 dB (A) is the sound pressure corresponding to the maximum permissible volume which is by law (in some countries) allowed to affect your hearing for the duration of a working day. It is used as a basis according to the specifications of industrial medicine. Higher volumes or longer durations can damage your hearing. At higher volumes, the duration must be shortened in order to prevent damage. The following are sure signs that you have been subjected to excessive noise for too long a time:

- You can hear ringing or whistling sounds in your ears.
- You have the impression that you can no longer hear high notes.

Responsible for any content:

Adam Hall GmbH

Daimlerstraße 9
D-61267 Neu-Anspach

Phone: +49 (0) 60 81 / 94 19 - 0
Fax: +49 (0) 60 81 / 94 19 - 1000

Geschäftsführer: David Kirby

Register court:

Local Court Bad Homburg v.d.H. HRB Nr. 8076

Responsible for content according to § 10 paragraph 3 MDSStV:

David Kirby

UStId-Nr. DE114114041
WEEE-Reg.-Nr. De55207035

EG-Konformitätserklärung

Diese Geräte entsprechen den grundlegenden Anforderungen und den weiteren Vorgaben der Richtlinien 1999/5/EU, 89/336/EU und 73/23/EU.

CE Declaration of Conformity

This equipment is in compliance with the essential requirement and other relevant provisions of Directives 1999/5/EC, 89/336/ES or 73/23/EC.