

---

Ross Video Limited

**FSS-6800 and FDS-6800 Series  
Passive Optical Splitters  
User Manual**



  
**ROSS**  
Live Production Technology

  
open**Gear**

---

## FSS-6800 and FDS-6800 Series • Passive Optical Splitters User Manual

- Ross Part Number: **6802DR-004-02**
- Release Date: July 22, 2011. Printed in Canada.

The information contained in this manual is subject to change without notice or obligation.

---

### Copyright

© 2011 **Ross Video Limited**. All rights reserved.

Contents of this publication may not be reproduced in any form without the written permission of Ross Video Limited. Reproduction or reverse engineering of copyrighted software is prohibited.

---

### Patents

This product is protected by the following US Patents: 4,205,346; 5,115,314; 5,280,346; 5,561,404; 7,034,886; 7,508,455; 7,602,446; 7,834,886; 7,914,332. This product is protected by the following Canadian Patents: 2039277; 1237518; 1127289. Other patents pending.

---

### Notice

The material in this manual is furnished for informational use only. It is subject to change without notice and should not be construed as commitment by Ross Video Limited. Ross Video Limited assumes no responsibility or liability for errors or inaccuracies that may appear in this manual.

---

### Trademarks

-  is a trademark of Ross Video Limited.
- Ross, ROSS, ROSS® are registered trademarks of Ross Video Limited.
- openGear® is a registered trademark of Ross Video Limited.
- DashBoard Control System™ is a trademark of Ross Video Limited.
- All other product names and any registered and unregistered trademarks mentioned in this guide are used for identification purposes only and remain the exclusive property of their respective owners.

---

# Important Regulatory and Safety Notices

Before using this product and any associated equipment, refer to the “**Important Safety Instructions**” listed below to avoid personnel injury and to prevent product damage.

Products may require specific equipment, and/or installation procedures to be carried out to satisfy certain regulatory compliance requirements. Notices have been included in this publication to call attention to these specific requirements.

## Symbol Meanings



---

*This symbol on the equipment refers you to important operating and maintenance (servicing) instructions within the Product Manual Documentation. Failure to heed this information may present a major risk of damage or injury to persons or equipment.*

---



---

**Warning** — The symbol with the word “**Warning**” within the equipment manual indicates a potentially hazardous situation which, if not avoided, could result in death or serious injury.

---



---

**Caution** — The symbol with the word “**Caution**” within the equipment manual indicates a potentially hazardous situation which, if not avoided, may result in minor or moderate injury. It may also be used to alert against unsafe practices.

---



---

**Notice** — The symbol with the word “**Notice**” within the equipment manual indicates a situation, which if not avoided, may result in major or minor equipment damage or a situation which could place the equipment in a non-compliant operating state.

---



---

**ESD Susceptibility** — This symbol is used to alert the user that an electrical or electronic device or assembly is susceptible to damage from an ESD event.

---

## Important Safety Instructions



---

**Caution** — This product is intended to be a component product of the DFR-8300 series frame. Refer to the DFR-8300 series frame User Manual for important safety instructions regarding the proper installation and safe operation of the frame as well as its component products.

---



---

**Warning** — Certain parts of this equipment namely the power supply area still present a safety hazard, with the power switch in the OFF position. To avoid electrical shock, disconnect all A/C power cards from the chassis’ rear appliance connectors before servicing this area.

---



---

**Warning** — Service barriers within this product are intended to protect the operator and service personnel from hazardous voltages. For continued safety, replace all barriers after any servicing.

*This product contains safety critical parts, which if incorrectly replaced may present a risk of fire or electrical shock. Components contained with the product’s power supplies and power supply area, are not intended to be customer serviced and should be returned to the factory for repair. To reduce the risk of fire, replacement fuses must be the same time and rating. Only use attachments/accessories specified by the manufacturer.*

---

## EMC Notices

### ***United States of America FCC Part 15***

This equipment has been tested and found to comply with the limits for a class A Digital device, pursuant to part 15 of the FCC Rules. These limits are designed to provide reasonable protection against harmful interference when the equipment is operated in a commercial environment. This equipment generates, uses, and can radiate radio frequency energy and, if not installed and used in accordance with the instruction manual, may cause harmful interference to radio communications. Operation of this equipment in a residential area is likely to cause harmful interference in which case the user will be required to correct the interference at his own expense.



---

**Notice** — *Changes or modifications to this equipment not expressly approved by Ross Video Limited could void the user's authority to operate this equipment.*

---

### **CANADA**

This Class "A" digital apparatus complies with Canadian ICES-003.

Cet appareil numérique de la classe "A" est conforme à la norme NMB-003 du Canada.

### **EUROPE**

This equipment is in compliance with the essential requirements and other relevant provisions of **CE Directive 93/68/EEC**.

### **INTERNATIONAL**

This equipment has been tested to **CISPR 22:1997** along with amendments **A1:2000** and **A2:2002**, and found to comply with the limits for a Class A Digital device.



---

**Notice** — *This is a Class A product. In domestic environments, this product may cause radio interference, in which case the user may have to take adequate measures.*

---

## Maintenance/User Serviceable Parts

Routine maintenance to this openGear product is not required. This product contains no user serviceable parts. If the module does not appear to be working properly, please contact Technical Support using the numbers listed under the "Contact Us" section on the last page of this manual. All openGear products are covered by a generous 5-year warranty and will be repaired without charge for materials or labor within this period. See the "Warranty and Repair Policy" section in this manual for details.

---

# Important Laser Safety Measures and Notices

Before using this product and any associated equipment, refer to the sections below so as to avoid personnel injury and to prevent product damage. For further safety information when using fiber products, consult the following publications:

- *IEC-60825- 2, Safety of Laser Products - Part 2: Safety of Optical Fiber Communication Systems (OFCS)* (for use outside of the U.S.A.)
- *ANSI Z136.2, Safe Use of Optical Fiber Communication Systems Utilizing Laser Diode and LED Sources* (for use in the U.S.A.)

Products may require specific equipment, and /or installation procedures be carried out to satisfy certain regulatory compliance requirements.



---

**Caution** — *Before operating or servicing this product, all personnel should be familiar with laser safety and fiber handling practices.*

---

## Safety Measures for Operation

During normal operation of this product, heed the following safety measures:

- Do not stare at, or into, broken, or damaged, fibers.
- Do not stare at, or into, optical connectors.
- Only properly trained and authorized personnel shall be permitted to perform laser/fiber optic operations.
- Ensure that appropriate labels are displayed in plain view and in close proximity to the optical port on the protective housing/access panel of the terminal equipment.

## Safety Measures for Maintenance and Servicing



---

**Warning** — *Do not use optical equipment, such as a microscope or an eye loupe, to stare at the energized fiber end. Doing so may damage your eyes.*

---

During maintenance and servicing of this product, only properly trained and authorized personnel shall be allowed to use optical test or diagnostic equipment.

## Laser Information



---

**CLASS 1 LASER PRODUCT**  
*IEC 60825-1:2007*

**Caution** — *INVISIBLE LASER RADIATION WHEN OPEN. AVOID EXPOSURE TO THE BEAM.*

---

---

## Environmental Information

**The equipment that you purchased required the extraction and use of natural resources for its production. It may contain hazardous substances that could impact health and the environment.**

To avoid the potential release of those substances into the environment and to diminish the need for the extraction of natural resources, Ross Video encourages you to use the appropriate take-back systems. These systems will reuse or recycle most of the materials from your end-of-life equipment in an environmentally friendly and health conscious manner.

The crossed-out wheeled bin symbol invites you to use these systems.

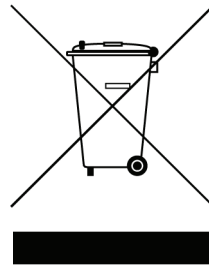

If you need more information on the collection, reuse, and recycling systems, please contact your local or regional waste administration. You can also contact Ross Video for more information on the environmental performances of our products.

---

## Company Address



### **Ross Video Limited**

8 John Street  
Iroquois, Ontario  
Canada, K0E 1K0

### **Ross Video Incorporated**

P.O. Box 880  
Ogdensburg, New York  
USA 13669-0880

---

General Business Office: (+1) 613 • 652 • 4886

Fax: (+1) 613 • 652 • 4425

Technical Support: (+1) 613 • 652 • 4886

After Hours Emergency: (+1) 613 • 349 • 0006

E-mail (Technical Support): [techsupport@rossvideo.com](mailto:techsupport@rossvideo.com)

E-mail (General Information): [solutions@rossvideo.com](mailto:solutions@rossvideo.com)

Website: <http://www.rossvideo.com>





# Contents

- Introduction** **1**
  - Overview..... 1-2
  - Features..... 1-2
  - Functional Block Diagrams ..... 1-3
  - Documentation Terms and Conventions..... 1-5
  
- Installation** **2**
  - Before You Begin ..... 2-2
    - Unpacking..... 2-2
    - Working with Fiber Optic Connectors ..... 2-2
  - Installing a Passive Optical Splitter ..... 2-3
    - Rear Modules for the Passive Optical Splitters ..... 2-3
    - Installing a Rear Module ..... 2-3
    - Removing a Passive Optical Splitter ..... 2-4
  - Cabling for the Passive Optical Splitters ..... 2-5
    - Cabling Overview..... 2-5
    - Installing and Removing Fiber Optic Cables ..... 2-6
  
- Specifications** **3**
  - FSS-6800 Series Technical Specifications ..... 3-2
  - FDS-6800 Series Technical Specifications..... 3-3
  
- Service Information** **4**
  - Troubleshooting Checklist..... 4-2
  - Warranty and Repair Policy..... 4-3



# Introduction

---

## In This Chapter

This chapter contains the following sections:

- Overview
- Functional Block Diagrams
- Documentation Terms and Conventions

## A Word of Thanks

Congratulations on choosing an openGear **FSS-6800 and FDS-6800 series Passive Optical Splitters**. Your FSS-6800 and FDS-6800 series are part of a full line of Digital Products within the openGear Terminal Equipment family of products, backed by Ross Video's experience in engineering and design expertise since 1974.

You will be pleased at how easily your new Passive Optical Splitters fit into your overall working environment. Equally pleasing is the product quality, reliability and functionality. Thank you for joining the group of worldwide satisfied Ross Video customers!

Should you have a question pertaining to the installation or operation of your Passive Optical Splitters, please contact us at the numbers listed on the back cover of this manual. Our technical support staff is always available for consultation, training, or service.

---

## Overview

The FSS-6800 and FDS-6800 series are passive optical splitters, using Planar Lightwave Circuit (PLC) technology, that takes in an input signal and splits it into several output signals. The FSS-6800 and FDS-6800 series is an implementation of CWDM takes an optical signal and splits it to two or more outputs but while using no electrical power. It separates the wavelengths using passive optical components. The FSS-6800 and FDS-6800 series functions like a distribution amplifier on optical signals. All splitters pass all wavelengths from 1260nm to 1650nm.

The FSS-6800 and FDS-6800 series are passive products that fit into the DFR-8321 series frame while drawing no power. The cards cannot be detected by DashBoard or SNMP as there is nothing to control or monitor.

The FSS-6800 and FDS-6800 series offer a low cost method of distributing an optical signal from one source to many destinations. This is achieved at the expense of optical power, where a 1:2 splitter will split the input signal power by 50% to each output. The cost savings are achieved without the need to return to the electrical domain. The cost savings are even higher if there are multiple wavelengths on the fiber.

There are three types of splitters: 1x2, 1x4, and 1x8. The optical power at the inputs is split to the outputs according to the ratio as follows:

- **FSS-6802** — This is a single 1x2 splitter with a 50% split and a maximum IL of 4dB.
- **FDS-6803** — This is a dual 1x2 splitter with a 50% split and a maximum IL of 4dB.
- **FSS-6804** — This is a single 1x4 splitter with a 25% split and a maximum IL of 8dB.
- **FDS-6805** — This is a dual 1x4 splitter with a 25% split and a maximum IL of 8dB.
- **FSS-6808** — This is a single 1x8 splitter with a 12.5% split and a maximum IL of 11dB.

## Features

The following features are standard for the FSS-6800 and FDS-6800 series:

- Available in 1x2, Dual 1x2, Dual 1x4, and Single 1x8 configurations
- Optical power split evenly across all outputs (50%, 25%, and 12.5%)
- Maximum input loss of 4dB on 1x2 splitters, 8dB on 1x4 splitters, and 11dB on 1x8 splitters
- Latching rear module to prevent accidental removal
- Works across a wide operating wavelength range from 1260nm to 1650nm
- Compatible with 1310nm, 1550nm, CWDM, and DWDM wavelengths
- Supports protocols and bit rates including 3G/HD/SD SDI, ASI, Ethernet
- Fully passive design, requiring no power
- Supports single-mode fiber
- LC/UPC optical connections
- Fits DFR-8321 series frames
- Fully compliant with openGear specifications
- 5-year transferable warranty

# Functional Block Diagrams

This section provides the workflow diagrams for the FSS-6800 and FDS-6800 series.

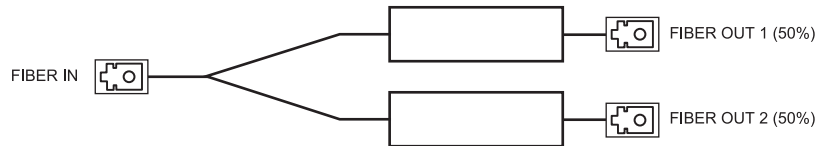

**Figure 1.1** FSS-6802 — Simplified Block Diagram

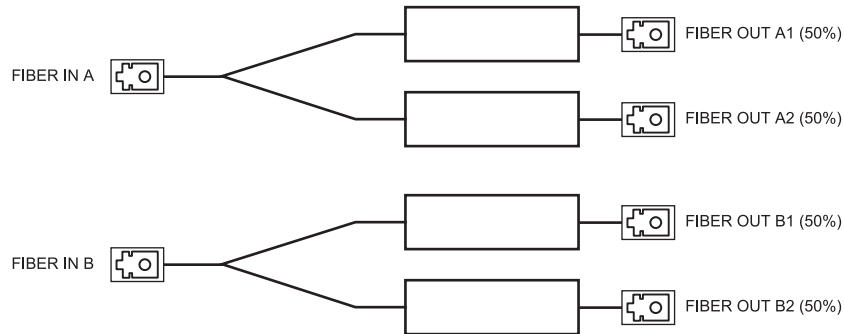

**Figure 1.2** FDS-6803 — Simplified Block Diagram

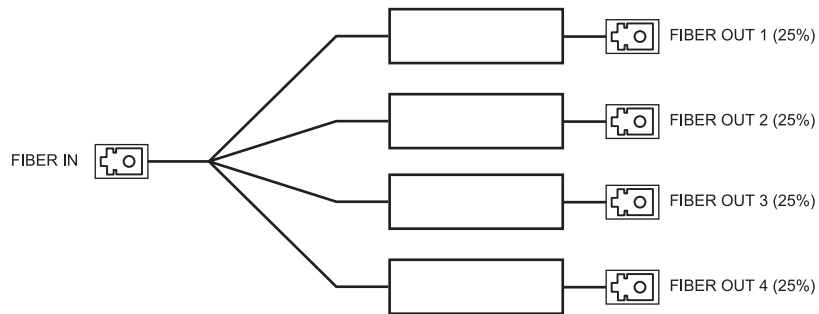

**Figure 1.3** FSS-6804 — Simplified Block Diagram

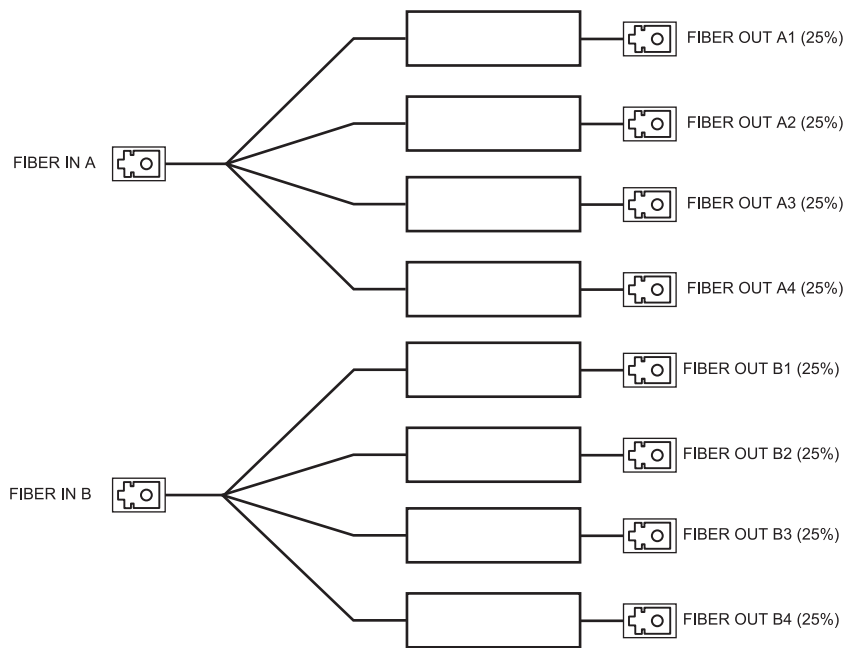

**Figure 1.4** *FDS-6805 — Simplified Block Diagram*

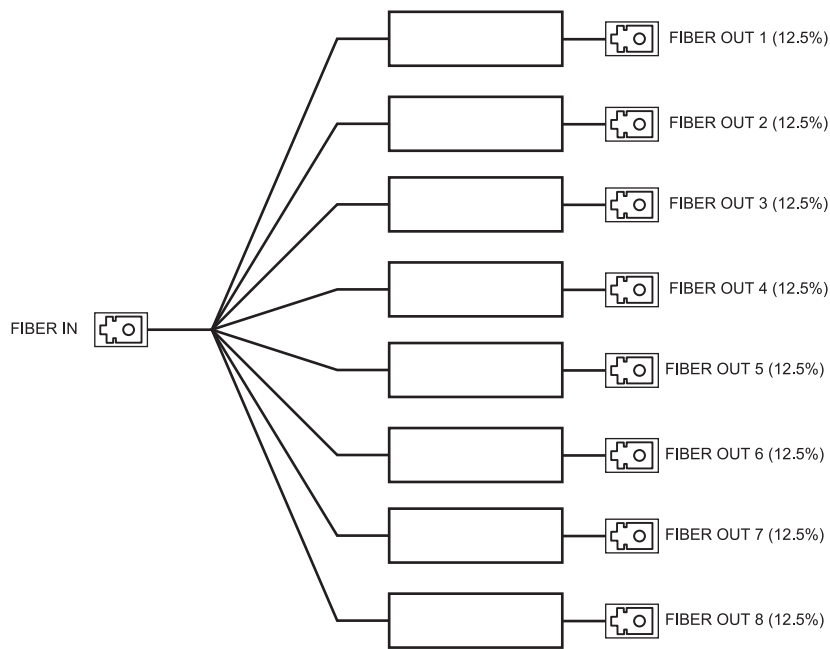

**Figure 1.5** *FSS-6808 — Simplified Block Diagram*

---

# Documentation Terms and Conventions

The following terms and conventions are used throughout this manual:

- “**Frame**” refers to DFR-8321 series frame that houses the FSS-6800 and FDS-6800 series, as well as any openGear frames.
- All references to the **DFR-8321 series frame** also includes all versions of the DFR-8321 frames and any available options unless otherwise noted.
- “**FSS-6800 series**” refers to the FSS-6802, FSS-6804, and FSS-6808 unless otherwise noted.
- “**FDS-6800 series**” refers to the FDS-6803, and FDS-6805 unless otherwise noted.
- “**Passive Optical Splitter**” refers to both the FSS-6800 and FDS-6800 series.
- “**Operator**” and “**User**” refer to the person who uses the FSS-6800 and FDS-6800 series.
- “**Board**”, and “**Card**” refer to openGear terminal devices within openGear frames, including all components and switches.
- “**System**” and “**Video system**” refer to the mix of interconnected production and terminal equipment in your environment.
- “**DashBoard**” refers to the DashBoard Control System™.
- The “**Operating Tips**” and “**Note**” boxes are used throughout this manual to provide additional user information.





# Installation

---

## In This Chapter

This chapter provides instructions for installing the FSS-6800 and FDS-6800 series into the frame, and cabling details. When installed, the modules are not visible through DashBoard nor SNMP and there are no card-edge controls.

The following topics are discussed:

- Before You Begin
- Installing a Passive Optical Splitter
- Cabling for the Passive Optical Splitters

---

## Before You Begin

Before proceeding with the instructions in this chapter, ensure that your DFR-8321 series frame is properly installed according to the instructions in the *DFR-8300 Series User Manual*.

### Unpacking

Unpack each Passive Optical Splitter you received from the shipping container and ensure that all items are included. If any items are missing or damaged, contact your sales representative or Ross Video directly.

### Working with Fiber Optic Connectors

Keep the following in mind when working with fiber optic connectors:

- Every time you are required to insert a connector into a device or mating sleeve, you must clean the connector. All exposed surfaces of the ceramic ferrule must be clean. Follow your facility practices of cleaning fiber optic connectors.
- Connectors must always be inserted into a device or have a dust cap on.
- A poor optical connection is often similar to a poor electrical connection. Try removing the connector, cleaning, and re-inserting the connector. A bad connection can result in experiencing instability of signal, high loss, or a noisy signal.

---

# Installing a Passive Optical Splitter

An installed Passive Optical Splitter blocks the card slots in the frame so that the modules are not damaged if a user attempts to slide a card into the slot occupied by the Passive Optical Splitter.

This section outlines how to install a rear module, and then the Passive Optical Splitter in a DFR-8321 series frame.



---

**Note** — Do not install the FSS-6800 or the FDS-6800 in a DFR-8310 series frame or in a DFR-8320 series frame.

---

## Rear Modules for the Passive Optical Splitters

Ensure to use the correct rear module when installing a Passive Optical Splitter. Note that the rear modules are included as part of the Passive Optical Splitter.

- **FSS-6802** — Use the **6800AR-001** Full Rear Module.
- **FDS-6803** — Use the **6800AR-001** Full Rear Module.
- **FSS-6804** — Use the **6800AR-001** Full Rear Module.
- **FDS-6805** — Use the **6800AR-002** Full Rear Module.
- **FSS-6808** — Use the **6800AR-002** Full Rear Module.

## Installing a Rear Module

If the rear module is already installed, proceed to the section “**Installing a Passive Optical Splitter**” on page 2-4.

Use the following procedure to install a rear module in your DFR-8321 series frame:

1. Locate the card frame slots on the rear of the frame you wish to install the rear module for.
2. Remove the Blank Plate from the slot you have chosen for the Passive Optical Splitter installation.
3. Install the bottom of the rear module in the Module Seating Slot at the base of the frame’s back plane.
4. Align the top hole of the rear module with the screw on the top-edge of the frame back-plane.
5. Using a Phillips screwdriver and the supplied screw, fasten the rear module to the back plane of the frame. Do not over tighten.
6. Ensure proper frame cooling and ventilation by having all rear frame slots covered with rear modules or Blank Plates.

This completes the procedure for installing a rear module in your DFR-8321 series frame.

## Installing a Passive Optical Splitter

All the components are enclosed in a metal box that fits into the frame card guides. The Passive Optical Splitters latch to the rear module to prevent accidental removal when the fiber optic cables are installed. This section outlines how to install a Passive Optical Splitter in a DFR-8321 series frame.



---

**Caution** — *Never attempt to look down the barrel of a connected fiber or device transmitting an optical signal. The transmitted light is not in the visible spectrum and may cause permanent eye damage. Turn off all laser sources before disconnecting devices.*

---

Use the following procedure to install a Passive Optical Splitter in a DFR-8321 series frame:

1. Open the frame door.
2. Insert the Passive Optical Splitter from the front of the frame until you hear a click from the latch on the rear module.
3. Ensure that the latch is locked by gently pulling the Passive Optical Splitter towards you.
4. Verify whether your **Rear Module Label** is self-adhesive by checking the back of the label for a thin wax sheet. You will need to remove this wax sheet before applying the label in order that the label can be affixed to the rear module surface.
5. Affix the supplied Rear Module Label to the connector area of the rear module.
6. Remove the dust cap(s) from the LC fiber optic port connectors on the unit end as needed when attaching the fiber cable(s).
  - Refer to the section “**Important Laser Safety Measures and Notices**” at the beginning of this manual for safety information when handling fiber optic components.
7. Ensure that the exposed surface of the ceramic ferrule of the connectors are clean. Refer to the section “**Working with Fiber Optic Connectors**” on page 2-2 for cleaning tips.
8. Cable your rear module as outlined in the section “**Cabling for the Passive Optical Splitters**” on page 2-5.

This completes the procedure for installing a Passive Optical Splitter in a DFR-8321 series frame.

## Removing a Passive Optical Splitter

Use the following procedure to remove a Passive Optical Splitter in a DFR-8321 series frame:

1. Remove all the fiber optic cables from the rear of the frame.
2. Open the frame door.
3. Disengage the Passive Optical Splitter from the rear module as follows:
  - From the back of the frame, squeeze the latch on the top of the rear module.
  - Push on the LC connectors to disengage the Passive Optical Splitter from the rear module.
4. Remove the Passive Optical Splitter from the front of the frame.
5. Close the frame door.

This completes the procedure for removing a Passive Optical Splitter in a DFR-8321 series frame.

# Cabling for the Passive Optical Splitters

This section provides information for connecting cables to the installed Passive Optical Splitter. Connect the input and output cables according to the following sections.



**Notice** — Every time you are required to insert a connector into a device or mating sleeve, you must clean the connector. All exposed surfaces of the ceramic ferrule must be clean. Follow your facility practices of cleaning fiber optic connectors.

Connectors must always be inserted into a device or have a dust cap on.

## Cabling Overview

The following diagrams provide a cabling overview for the Passive Optical Splitters.

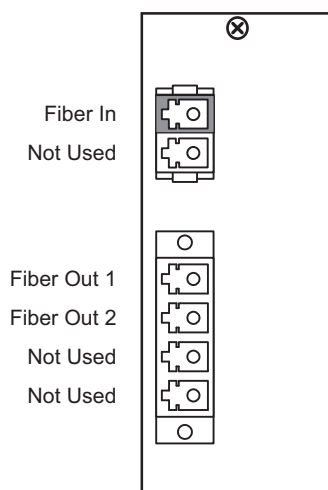

**Figure 2.1** Cable Connections for the FSS-6802

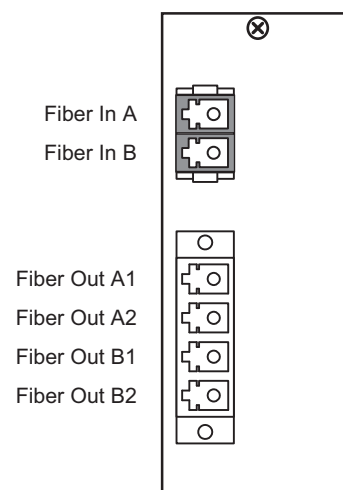

**Figure 2.2** Cable Connections for the FDS-6803

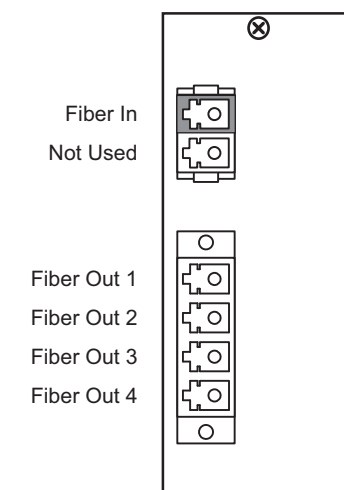

**Figure 2.3** Cable Connections for the FSS-6804

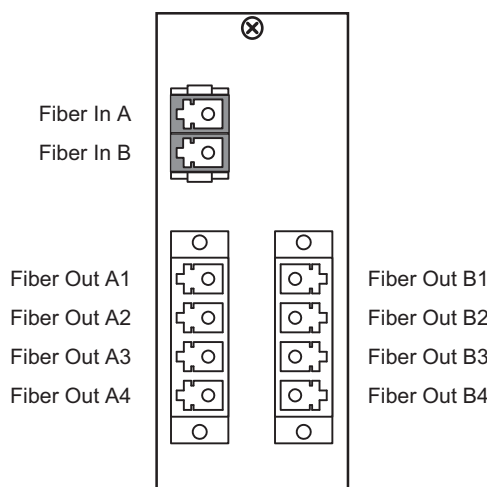

**Figure 2.4** Cable Connections for the FDS-6805

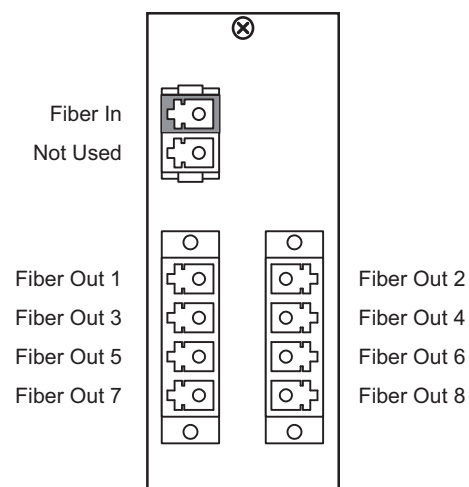

**Figure 2.5** Cable Connections for the FSS-6808

## Installing and Removing Fiber Optic Cables

The limited space between connectors and the accumulated fiber optic cables around the rear modules makes it difficult to gain access to individual connectors. Ross Video supplies an Optic Cable Tool to assist in the installing and removal of individual fiber optic LC connectors. The Optic Cable Tool can be used with single-latch, dual-latch, and duplex-latch connectors.

This section provides general instructions for using the Optic Cable Tool to install and remove fiber optic cables from a DFR-8321 series frame.

### Installing a Fiber Optic Cable

Use the following procedure to install a fiber optic cable using the Optic Cable Tool:

1. Ensure the dust caps are removed from the cable connectors and the rear module adapter.
2. Position the bottom lip of the Optic Cable Tool on the connector boot, ensuring that the top lip makes contact just behind the notch at the end of the latch. (**Figure 2.6**)

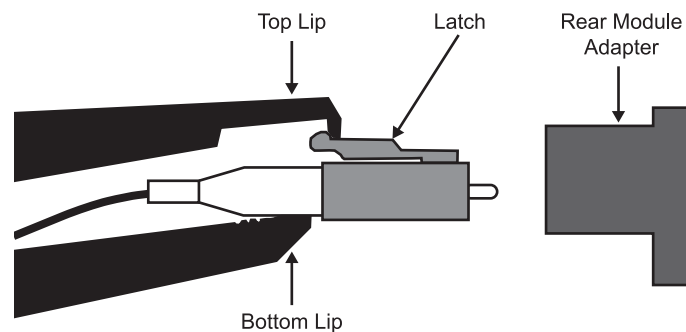

**Figure 2.6** Positioning the Optic Cable Tool — Single-Latch Connector

3. Gently squeeze the handles of the Optic Cable Tool to compress the latch.



**Caution** — Do not apply excess pressure when installing or removing the connector. Doing so may damage the latch, the connector, or both.

4. Insert the connector into the rear module adapter by gently pushing the connector as far forward, towards the rear module adapter, as possible.
5. Release the latch.
6. Re-position the Optic Cable Tool so that the top lip sits behind the latch. (**Figure 2.7**)

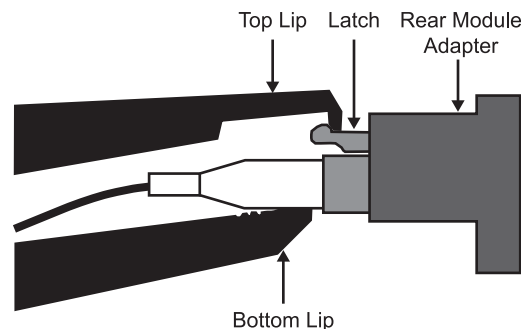

**Figure 2.7** Re-positioning the Optic Cable Tool — Single-Latch Connector

7. Gently push the connector to lock the connector into the rear module adapter.

This completes the procedure for installing a fiber optic cable using the Optic Cable Tool.

## Removing a Fiber Optic Cable

Use the following procedure to remove a fiber optic cable using the Optic Cable Tool:

1. Position the bottom lip of the Optic Cable Tool on the connector boot, ensuring that the top lip makes contact just behind the notch at the end of the latch. (**Figure 2.8**)

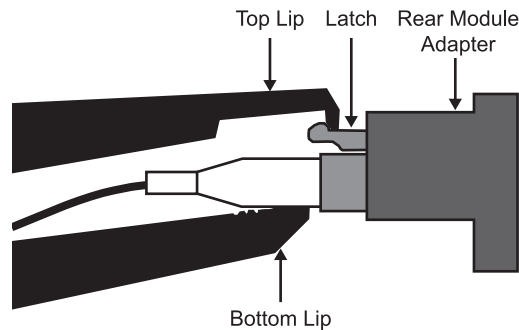

**Figure 2.8** Positioning the Optic Cable Tool — Single-Latch Connector

2. Gently squeeze the handles of the Optic Cable Tool to compress the latch.



---

**Caution** — Do not apply excess pressure when installing or removing the connector. Doing so may damage the latch, the connector, or both.

---

3. Remove the connector from the rear module adapter by slowly pulling the Optic Cable Tool towards you.

This completes the procedure for removing a fiber optic cable using the Optic Cable Tool.





# Specifications

---

## In This Chapter

This chapter includes the technical specifications for the Passive Optical Splitters. Note that specifications are subject to change without notice.

The following topics are discussed:

- FSS-6800 Series Technical Specifications
- FDS-6800 Series Technical Specifications

---

# FSS-6800 Series Technical Specifications

This section provides the technical specifications for the FSS-6800 series.

**Table 3.1 FSS-6800 Series Technical Specifications**

Category	Parameter	Specification
Optical	Supported Wavelengths	1260nm to 1650nm
	Return Loss	minimum 50dB
	Maximum Insertion Loss	FSS-6802: 4dB FSS-6804: 8dB FSS-6808: 11dB
	Uniformity	FSS-6802: 0.4dB FSS-6804: 0.6dB FSS-6808: 0.8dB
	Directivity	55dB
	Number of slots required per unit	2
	Connector Type	Single Mode, LC/UPC

---

## FDS-6800 Series Technical Specifications

This section provides the technical specifications for the FDS-6800 Series.

**Table 3.2 FSS-6800 Series Technical Specifications**

Category	Parameter	Specification
Optical Input/Output	Supported Wavelengths	1260nm to 1650nm
	Return Loss	minimum 50dB
	Maximum Insertion Loss	FDS-6803: 4dB FDS-6805: 8dB
	Uniformity	FDS-6803: 0.4dB FDS-6805: 0.6dB
	Directivity	55dB
	Number of slots required per unit	2
	Connector Type	Single Mode, LC/UPC



# Service Information

---

## In This Chapter

This chapter contains the following sections:

- Troubleshooting Checklist
- Warranty and Repair Policy

---

## Troubleshooting Checklist

Routine maintenance to this openGear product is not required. In the event of problems with your Passive Optical Splitters, the following basic troubleshooting checklist may help identify the source of the problem. If the frame still does not appear to be working properly after checking all possible causes, please contact your openGear products distributor, or the Technical Support department at the numbers listed under the “**Contact Us**” section.

1. **Visual Review** — Performing a quick visual check may reveal many problems, such as connectors not properly seated or loose cables. Check the card, the frame, and any associated peripheral equipment for signs of trouble.
2. **Clean Fiber Interfaces** — Ensure the fiber interfaces are clean with a Fiber Inspection Scope. Clean the interfaces if necessary.
3. **Verify Inputs and Outputs** — Verify the power and wavelengths of the inputs and outputs using a Wavelength Power Meter.

---

## Warranty and Repair Policy

The FSS-6800 and FDS-6800 series is warranted to be free of any defect with respect to performance, quality, reliability, and workmanship for a period of FIVE (5) years from the date of shipment from our factory. In the event that your FSS-6800 and FDS-6800 series proves to be defective in any way during this warranty period, Ross Video Limited reserves the right to repair or replace this piece of equipment with a unit of equal or superior performance characteristics.

Should you find that the FSS-6800 or FDS-6800 series has failed after your warranty period has expired, we will repair your defective product should suitable replacement components be available. You, the owner, will bear any labor and/or part costs incurred in the repair or refurbishment of said equipment beyond the FIVE (5) year warranty period.

In no event shall Ross Video Limited be liable for direct, indirect, special, incidental, or consequential damages (including loss of profits) incurred by the use of this product. Implied warranties are expressly limited to the duration of this warranty.

This User Manual provides all pertinent information for the safe installation and operation of your openGear Product. Ross Video policy dictates that all repairs to the FSS-6800 and FDS-6800 series are to be conducted only by an authorized Ross Video Limited factory representative. Therefore, any unauthorized attempt to repair this product, by anyone other than an authorized Ross Video Limited factory representative, will automatically void the warranty. Please contact Ross Video Technical Support for more information.

### In Case of Problems

Should any problem arise with your FSS-6800 and FDS-6800 series, please contact the Ross Video Technical Support Department. (Contact information is supplied at the end of this publication.)

A Return Material Authorization number (RMA) will be issued to you, as well as specific shipping instructions, should you wish our factory to repair your FSS-6800 and FDS-6800 series. If required, a temporary replacement frame will be made available at a nominal charge. Any shipping costs incurred will be the responsibility of you, the customer. All products shipped to you from Ross Video Limited will be shipped collect.

The Ross Video Technical Support Department will continue to provide advice on any product manufactured by Ross Video Limited, beyond the warranty period without charge, for the life of the equipment.

# Contact Us

Contact our friendly and professional support representatives for the following:

- Name and address of your local dealer
- Product information and pricing
- Technical support
- Upcoming trade show information

<b>PHONE</b>	<b>General Business Office and Technical Support</b>	613 • 652 • 4886
	<b>After Hours Emergency</b>	613 • 349 • 0006
	<b>Fax</b>	613 • 652 • 4425
<b>E-MAIL</b>	<b>General Information</b>	solutions@rossvideo.com
	<b>Technical Support</b>	techsupport@rossvideo.com
<b>POSTAL SERVICE</b>	<b>Ross Video Limited</b>	8 John Street, Iroquois, Ontario, Canada K0E 1K0
	<b>Ross Video Incorporated</b>	P.O. Box 880, Ogdensburg, New York, USA 13669-0880

## Visit Us

Please visit us at our website for:

- Company information
- Related products and full product lines
- On-line catalog
- News
- Testimonials

[www.rossvideo.com](http://www.rossvideo.com)