

Item NO.	Part No.	Description English	Qty
1	01014144	Screw Top	1
2	02021075	Plug	1
3	01040213	Air Release Valve	2
4	02011032	O-Ring for Air Release Valve	2
5	03017320	Hose Clamp	2
6	01150200	4" PVC Tube (Imperial)	1
7	89280103	2.0" Union Set (3 Pieces) With O-Ring	1
8	03018167	Stand	2
9	01170057	Union	2
10	01020019	Ring Lock for UV-C	2
11	02080008	O-Ring for Lid	1
12	01014143	UV-C Lid	1
13	01021136	Screw for Lid	1
14	01021137	Screw for UV-C Lamp	1
15	01321008	Screw for Connection Box	1
16	02021076	Plug	1
17	89042001	UV-C Lamp (15W)	1
	89042002	UV-C Lamp (25W)	1
	89042003	UV-C Lamp (30W)	1
	89042004	UV-C Lamp (55W)	1
18	02011081	Round Plastic Plug	1
19	03011023	M5*35 Screw	4
20	87013019	Plastic Wall Fitting for Screw	4
21	04014052	Quartz Tube (for 15W and 25W)	1
	04014053	Quartz Tube (for 30W and 55W)	1

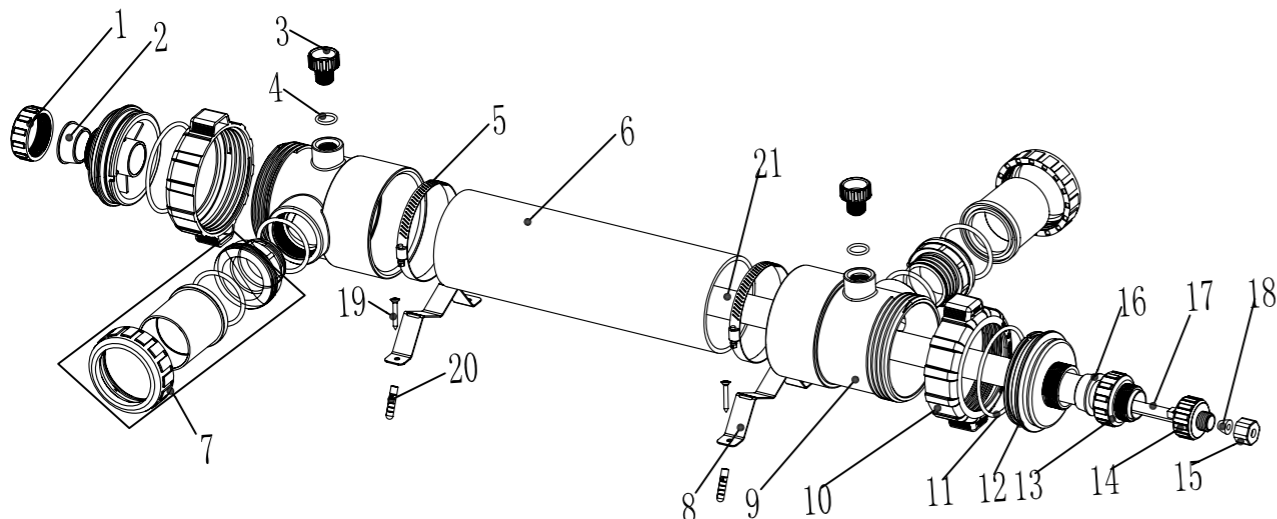

UV-C Fish Pond Disinfection System User Manual

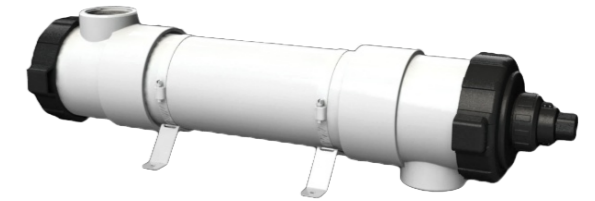

⚠ Please read carefully through these instructions for use before installing this device.

⚠ **Warning:** This device produces harmful radiation. Direct contact could impair the eyes and skin. Only check the operation of the UV-C lamp through the transparent components of the unit.

⚠ The installation of this device must be done by qualified fitter or technician and complied with the relevant regulations from the government. Improper installation will harm the user or causing death. Always remove the plug from the socket before carrying out any maintenance or repair work on the unit. Please read carefully the below instructions before using this device.

SPECIFICATION:

Product No	Model No	Flow rate (m ³ /h)	Fish Pond Volume (m ³)	Input Voltage (V)	Input Power (W)	Connection
88046317	FOS-UV-5T	14.4	5	220-230	15	1.5"/2"
88046318	FOS-UV-7T	14.4	7	220-230	25	1.5"/2"
88046319	FOS-UV-8T	14.4	8	220-230	30	1.5"/2"
88046320	FOS-UV-14T	14.4	14	220-230	55	1.5"/2"

FEATURES:

1. Durable UV-C lamp with Long Life span, for more than 10,000 hours.
2. High quality Quartz tube provides more than 99% transmittance rate.
3. High quality UV-C lamp that achieve 98% sterilization rate.
4. Save 80% of Chlorine and other chemicals.
5. Maintain bacteria-free and purified water with effective sterilization.
6. Easy operation, less maintenance and more carefree use of your fish pond.

PRODUCT DIMENSION:

Model No	Product Dimension(mm)			
	A	B	C	D
FOS-UV-5T/7T	694	431	180	166
FOS-UV-8T/14T	1144	881	180	166

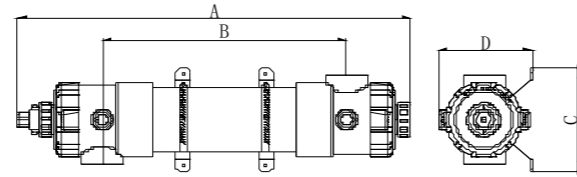

SAFETY:

1. This device produces harmful radiation. Direct contact could impair the eyes and skin. Only check the operation of the UV-C lamp through the transparent components of the unit.
2. Always comply with the electricity company's regulations with regard to any permanent connection to the mains. If there is any doubt regarding the connection, consult a recognized fitter or the electricity company. Always work with a residual current-operated circuit-breaker.
3. The device must be switched off if water treatment agents or medication are used.
4. Always remove the plug from the socket before carrying out any maintenance or repair work on the unit. Never insert / pull the plug from the socket when you are standing in water or if your hands are wet.
5. Never submerge this device in water.
6. Keep children away from this device and from the cable.
7. The cable of the device cannot be replaced. The complete electrical unit must be replaced if there is any damage to the power cable.
8. Once the device has been switched off, the lamp will remain hot for around 10 minutes.
9. Do not use the device if any of the components are damaged (especially the quartz tube).
10. Remove the device if there is a risk of freezing during the winter months.
11. This product can only be used according to the guidelines described in these instructions for use.

INSTALLATION:

1. Test the input voltage before installation! The voltage must be within 220-230V±10% to ensure normal operation.
2. An area of approx. 1.5m must be available at the top of the device in order to be able to replace the lamp smoothly without having to dismantle the complete device.
3. Please refer to diagram 1 for the system installation; the actual installation may vary from different situation.
4. The two stands for the device must be mounted on the floor or on the wall.
5. It is recommended to install a valve at the water inlet and outlet for easy maintenance.
6. Activate the pump and check that there is flow and no leakage at the screw top. If there is leakage, fasten the screw top and check if there is any damage at the sealing ring. Never use force! The quartz glass is very fragile.

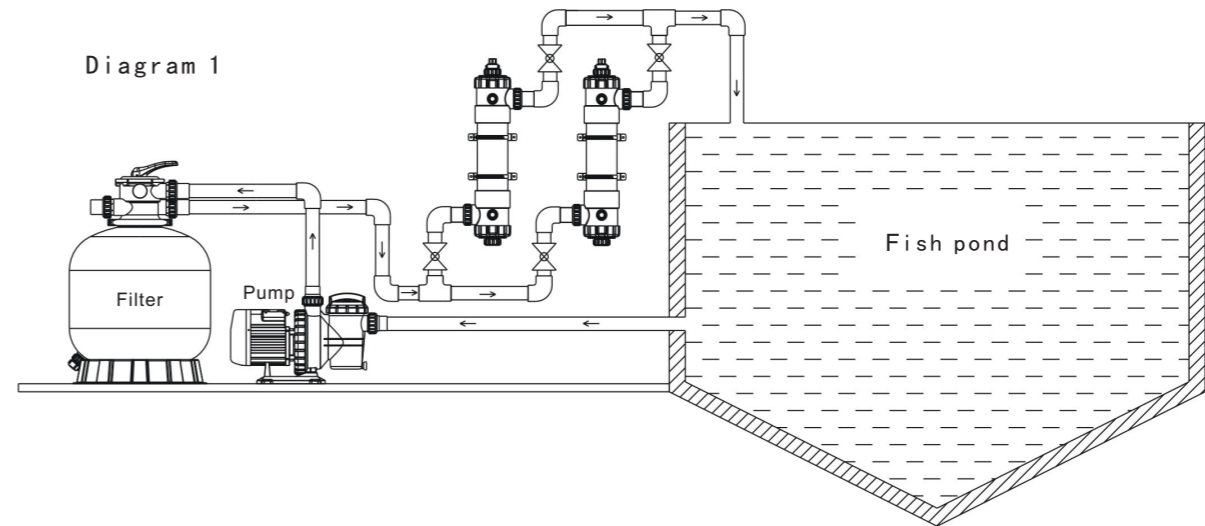

OPERATION:

1. This device produces harmful radiation; direct contact could impair the eyes and skin. Keep children away from this device and from the cable.
2. After the installation, activate the pump and check the water flow for 5 mins to ensure there is no leakage before operating the device.
3. Insert the plug of the UV-C device into a wall socket with a safety ground. Check whether the lamp is operating via transparent outlet of the unit. (the light is "On" when the device is in normal operation)
4. Always switch off water supply then switch off the power supply when the operation stops, to avoid unsterilized water contaminating the pool water.
5. When the device is in use, check the system if there is any leakage, fasten the loosen screw cap and lock nut. If the lamp is not working, shut the power supply, unscrew the screw cap and pull the lamp out from the top of the device, carefully remove the lamp from the lamp holder and replace it with a new lamp. No need to dismantle the whole device.

MAINTENANCE:

1. Always switch off the power supply and water supply during maintenance.
2. Always switch off the power supply and water supply when replacing the UV-C lamp and Quartz tube.
3. After the maintenance/dismantle, it is recommended to clean the device. If there are algae on the quartz tube, clean it with a soft cloth.
4. When replacing the quartz tube or sealing ring, unscrew the screw cap and carefully remove the lamp from the lamp holder then replace the quartz tube. For safety reason, it is recommended to replace the quartz tube by two qualified fitter or technician together.
5. The UV-C lamp must be replaced after 10,000 operating hours.

REMINDER:

1. Never frequently switch on/off the device in short period of time, or it will reduce the life span of the lamp.
2. Check the lamp only via the transparent outlet in order to protect the eyes.