

# Concord LCD Keypad with 2-Way Voice Installation Sheet

## Description

The Concord LCD Keypad with 2-Way Voice provides control of all programming and operation of compatible security systems.

The 2-line, 16-character display provides easy to read messages to indicate the current status of the system. The keypad includes police, fire, and auxiliary panic buttons that can be activated anytime. An internal piezo provides system status beeps for trouble and alarm indications.\* Two-way audio is achieved using an internal speaker and microphone combination.\*

A supervised hardwire zone provides an additional zone without added wiring to the panel. Opening the removable swing-down door reveals a label with basic system operating commands.

\* Not UL approved as a primary annunciator. Not investigated for use as two-way verification.

### Tools and Equipment needed

- 4-conductor, 18- or 22-gauge wire
- #2 Phillips screwdriver
- #6 screws and anchors (included)
- Screws for gang box installation
- Saw or utility knife for cutting wallboard

## Installation

### Installation Guidelines

- Mount the keypad in an environmentally controlled area (32°F to 120°F/0°C to 49°C).
- When mounting the keypad, allow at least 6 inches below it for the swing-down cover.
- When connecting two-way voice to the keypad, any additional speaker devices on the system should be connected in parallel with the keypad speaker connection. **Note:** Siren volume will be reduced if connected in series. *This information differs from the information listed in the Concord 4 Installation Manual.*
- Do not exceed the maximum available power given in the panel installation instructions.

- The hardwire zone is intended for use with intrusion sensors only. This zone input does not provide power for sensors such as PIRs, fire detectors, etc.
- Up to 16 keypads can be installed on a Concord 4 system of which a maximum of two can be connected to two-way audio or a single keypad plus an audio verification module.

**Table 1: Keypad Power Usage**

Current (mA)	Conditions
110	Maximum alarm current with the buzzer sounding and the keypad illuminated from a button press
60	Typical operation
23	Power saving mode (no panel AC power)

**Table 2: Maximum SuperBus and Audio Wire Lengths**

Wire gauge (unshielded or shielded)	Max. keypad wire length between keypad and panel
18	750 feet
22	300 feet

**Note:** Interlogix recommends using shielded cable to prevent crosstalk between the speaker and microphone.

**Table 3: Maximum Hardwire Zone Wire Lengths**

Wire gauge (unshielded or shielded)	Max. keypad zone wire length between keypad and sensor
22	100 feet

Hardwire zone End of Line (EOL) resistor should be 2K ohm.

### Installing the Mounting Plate

1. Place the keypad on a flat surface so that the mounting plate is facing as shown in Figure 1 on page 2.
2. Remove the mounting plate from the keypad as described in Figure 1 on page 2.

**Figure 1: Removing Mounting Plate From Keypad**

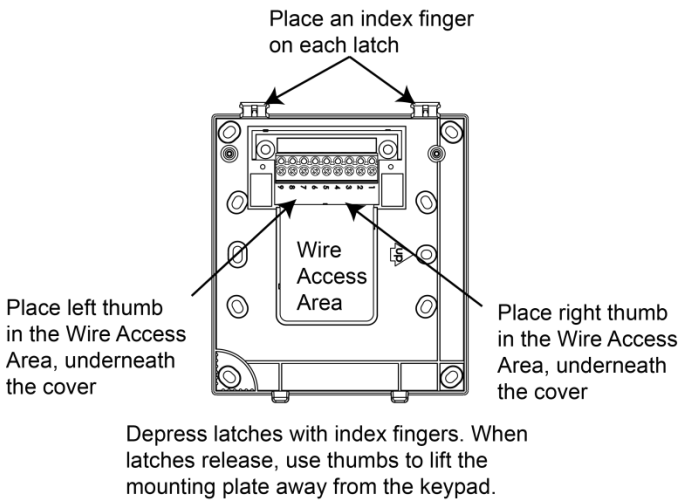

3. Place the mounting plate on the wall and mark the primary and tamper mounting holes, making sure to leave a 6 inch clearance below the keypad for the door to open. See Figure 2 below.

**Note:** Gang box mounting screws are not provided with this keypad.

4. Insert anchors into the wall at the marked locations where studs are not present.

5. Align the mounting plate over the selected mounting locations and secure the back plate using the screws provided.

**Note:** Do not over tighten screws or the mounting plate may bind and prevent the keypad from mounting properly.

**Figure 2: Marking the Mounting Holes**

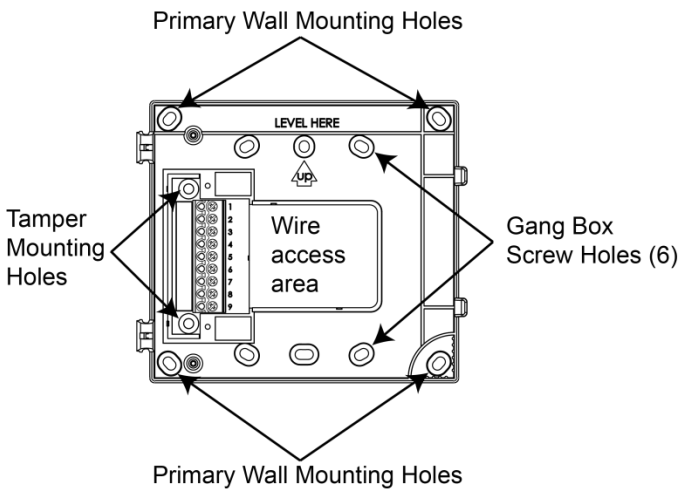

6. Cut a hole in the wall at the wire access area of the mounting plate to pull the wiring cable through.

**Optional Tamper Mounting**

**Note:** Tamper mounting hardware is not supplied with this product.

To enable the tamper function:

1. Remove the two small flathead screws that attach the terminal block plate to the mounting plate.
2. Mount according to the process above.

**Note:** Tamper screws must be installed into a stud.

**Wiring the Keypad**

**CAUTION:** Use static electricity precautions when handling electronic components. Utiliser les précautions de l'électricité statique lors de la manipulation des composants électroniques.

1. Remove the panel AC and backup battery power.
2. Run wires (18- or 22-gauge) from the panel and sensor to the keypad location.
  - 4-conductor (no 2-way voice) between panel and keypad
  - 8-conductor (with 2-way voice) between panel and keypad
3. When routing the wires, route all wiring connections from the access area directly to the terminal, keeping wires short and flat. No loops of wire should run outside the access area.

**Note:** Interlogix recommends using shielded cable to prevent crosstalk between the speaker and microphone.

- 2-conductor (to sensor) between keypad and hardwire sensor (if installed)

**Note:** Do not run any excess wire outside the access area as it will make the assembly of the keypad onto the mounting plate difficult.

**Wiring the Keypad – SB2000**

1. Pull the ground, +12 volt and bus wires through the access area.
2. Connect the Bus to the 9 position terminal block as shown in Figure 3 below.

**Figure 3: Connecting the Keypad**

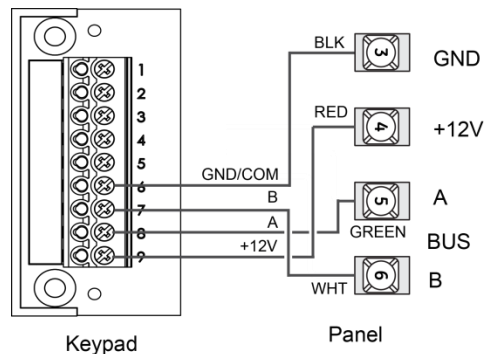

**Note:** For bus wire length over 150 feet, a 120 ohm termination resistor is needed across A to B at the panel.

### Wiring the Keypad – Speaker and Microphone

1. Pull the speaker and microphone wires through the access area.
2. Connect the speaker and microphone wires to the 9 position terminal block as shown in Figure 4 below, Figure 5 below and Figure 6 below.
3. If other audio devices will be installed on the system, wire accordingly as shown in the following diagrams.

**Note (1):** Interlogix recommends using shielded cable to prevent crosstalk between the speaker and microphone.

**Note(2):** The keypad is not UL approved as a primary annunciator.

**Note(3):** Installations requiring an AVM in addition to the Keypad Audio require the addition of a 10 K ohm resistor (included) on the MIC wire of the AVM to equalize the MIC performance of both devices.

Figure 6: Keypad to Audio Diagram (with Audio Verification Module)

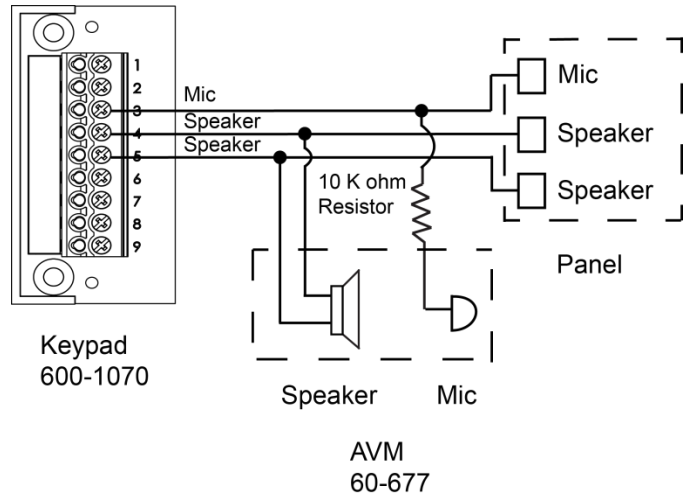
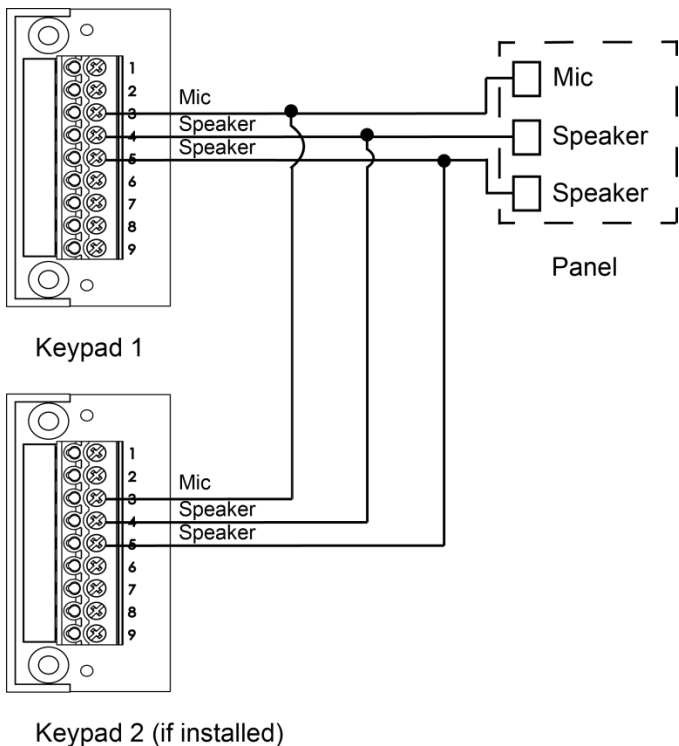

Figure 4: Keypad to Audio Diagram (keypad only)



### Wiring the Keypad – Hardwire Zone

1. Pull the hardwire zone wires through the access area.
2. Connect the hardwire zone wires to the 9 position terminal block as shown in Figure 7 below.
3. Insert the end-of-line (EOL) resistor at the last device in the loop. See Figure 7 below. **Note:** The EOL resistor must be located at the last device in the loop.
4. Use a maximum of five contacts.

**Note:** The keypad does not supply power for sensors. Sensor Zones must be of the normally open or closed contact type.

Figure 7: Hardwire Zone

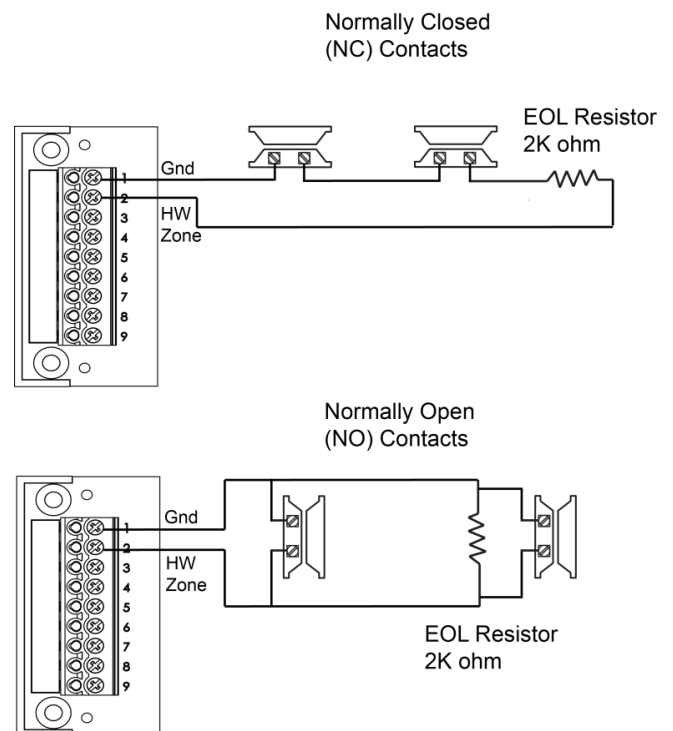
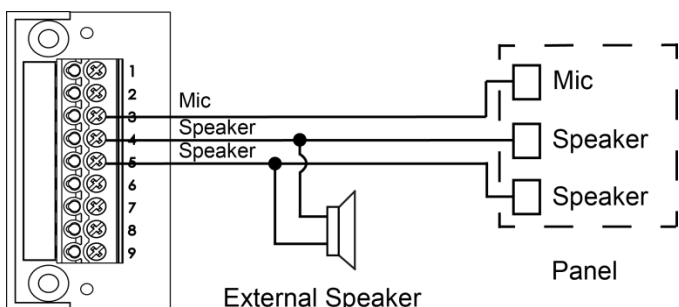

Figure 5: Keypad to Audio Diagram (multiple speakers)



## External Contact Wiring

**Table 4: External switches**

Normally closed	Normally open
Short = Tamper	Open = Tamper
2K ohm = Normal	Short = Alarm
Open = Alarm	2K ohm = Normal

**Note:** A bus failure will result in a zone trouble condition.

### Attaching the Keypad to the Mounting Plate

1. Align the right side of the keypad over the hooks on the mounting plate. See Figure 8 below.
2. Swing the left side of the keypad over the latches on the mounting plate, until the latches snap into place. See Figure 8 below.

**Figure 8: Attaching the Keypad to the Mounting Plate**

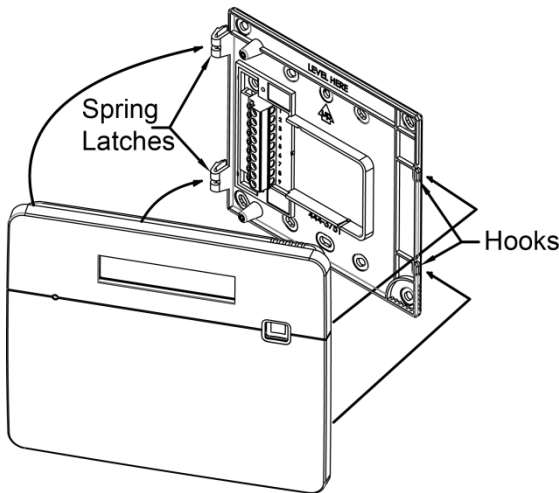

**Note:** To remove, depress both latches on the left side and then swing the left side of keypad away from the wall, removing the keypad from the hooks.

## Applying Decals

A set of decals is included with the keypad for labeling the function keys. For Concord 4, the function keys are programmed: Fire (F1), Auxiliary (F2) and Police (F3).

Carefully apply the function key decals (as needed) on the keypad as shown in Figure 9 below.

**Figure 9: Function Key Decals**

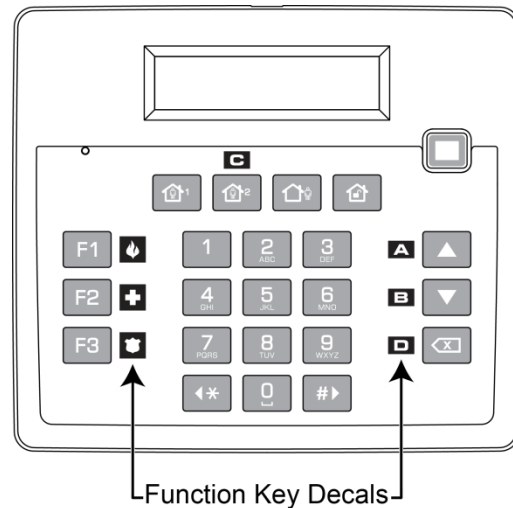

Please refer to Table 5 below or to the specific panel installation/user manual for more information on when specific key presses are required.

**Note:** The Auxiliary Alarm Key is not evaluated for and not to be used for UL 1637 (medical) applications.

**Table 5: Key Functions**

Key	Function
<b>A</b>	Scroll through available options at current menu tier
<b>B</b>	
<b>C</b>	Enter pauses when programming telephone numbers (no end user function)
<b>D</b>	Delete certain program settings Also used as Quick Exit key for end-user

## Power up and Bus Communication

Follow the steps below for powering up the panel and for verifying that the keypad and the panel are properly communicating with each other.

**Note:** Upon power up, the panel scans the bus for connected devices, assigns a unit number to each bus device, and automatically learns the device ID number of each bus device.

1. Verify that all wiring between the panel and keypad is correct.
2. Connect the panel battery and restore AC power. Alphanumeric keypads briefly show *SCANNING BUS DEVICES*, then displays date and time.

### Optional (steps 1 through 7)

1. At the keypad, enter program mode by pressing 8 + installer/dealer code (default = 4321) + 0 + 0. The keypad should display *SYSTEM PROGRAMMING*.

- Press **[Up]**. The display should show *SECURITY*.
- Press **[Up]** or **[Down]** until the display shows *ACCESSORY MODULES*, then press **[#]**. The display should show *BUS DEVICES*.
- Press **[#]**. The display shows the lowest device address and its ID. The following example shows what a device address display may look like:  
*UNIT - ID*  
*0—02110185\**  
 \*The 8-digit SuperBus ID number is also located on a label on the back of the keypad.
- Press **[Up]** or **[Down]** to cycle through all bus device addresses until the keypad appears.
- After verifying the keypad device ID, press **[\*]** repeatedly until the display shows *SYSTEM PROGRAMMING*.
- Press **[Up]** or **[Down]** until the display shows *EXIT PROGRAMMING READY*, then press **[#]**. The keypad should show the date and time display.

## Programming

To program options for the newly installed keypad (such as key beeps) see the specific panel *Installation Instructions*.

## Connecting the Keypad for System Programming Only

For installations that don't include an alphanumeric keypad as a permanent part of the system, connect one for system programming to the Programming Keypad Header on the panel.

To do this, first connect a Programming Keypad Cable (60-791) to the keypad wires. See the *Programming Keypad Cable Installation Instructions (P/N 466-1604)*, included with the cable). Then, use the appropriate procedure for connecting the keypad.

To connect a programming keypad to a Concord 4 panel:

- With the panel powered up, connect the cable to the Programming Keypad Header Pins. See Figure 10 below.

Figure 10: Connecting a Programming Keypad—Concord 4

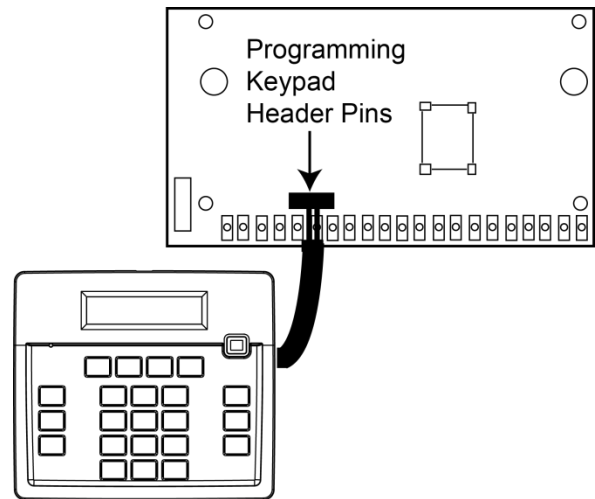

- Activate the keypad by pressing **[8]** + installer/dealer CODE + **[0]** + **[2]**.
- Enter program mode by pressing **[8]** + installer/dealer CODE + **[0]** + **[0]** and program the panel using the panel *Installation Instructions*.
- When programming is completed, disconnect the programming keypad.

## Testing

**Note:** Contact the central monitoring station before activating alarms to avoid dispatching local police and fire departments.

Test the keypad by arming/disarming the system, activating the keypad panics, bypassing sensors, and by turning chime and lights on/off to verify correct operation. Refer to the panel *User's Manual* for complete system operating instructions.

## Adjusting Display Brightness

The keypad display can be adjusted for easier viewing to help compensate for lighting conditions in the keypad location.

The brightness adjustment lightens or darkens the background.

To adjust display brightness:

- Enter user programming mode by pressing 9 + user, partition, or system master CODE. The display shows *SYSTEM MENU*, then *TIME AND DATE*.
- Press **[Down]** until the display shows *OPTIONS*, then press **[#]**. The display should show *DOWNLOADING ON/OFF (current setting)*.
- Press **[Down]** twice. The display should show *KEYPAD BRIGHTNESS 2 (default setting)*.
- Enter a setting from 0 (darkest background) to 3 (brightest background), then press **[#]**.
- The display flashes the entered selection, then stops after pressing **[#]** and displays the new setting and brightness level.

- Exit user programming mode.

## Status LEDs

The keypad has LEDs that indicate the current system status at a glance. Table 6 below explains LED behavior.

**Table 6: Status LEDs**

LED	System status
Solid blue (while backlights are on)	System is disarmed, status is normal
Solid red (while backlights are on)	System armed
Flashing red	System is in alarm
Flashing blue	System is disarmed, trouble or alarm condition present (for example protest, low battery, supervisory, bus trouble, tamper, open zone, etc.)

**Note:** Solid status LEDs display only when a key is pressed or backlighting is on. Flashing LEDs remain flashing until the fault or alarm condition is cleared.

## Door and Hinge Removal

- Remove the keypad from the mounting plate.
- Using a screwdriver, back out the hinge retainer screws 1/8". See Figure 11.
- Remove the door and hinges.

**Note:** Per SIA CP-01 2010 requirements, the door must remain attached and closed during normal operation.

**Figure 11: Door and Hinge Removal**

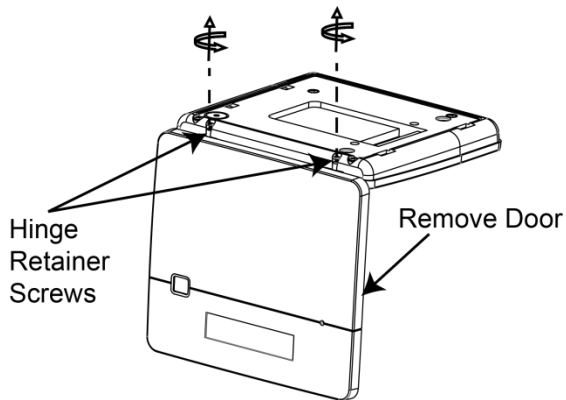

## Troubleshooting

Problem	Action/Solution
Keypad doesn't power up (no display and no beeps when keys are pressed).	<p>Check for correct wiring connections at keypad and panel terminals.</p> <p>Make sure panel battery is connected correctly and that the panel transformer is plugged in.</p> <p>Make sure panel transformer is not plugged into an electrical outlet controlled by a switch. Relocate transformer to an unswitched outlet location, if necessary.</p>
Keypad status blue LED is flashing and a trouble star is displayed on the LCD indicating a trouble condition and system doesn't respond to commands from keypad.	<p>Check for correct bus wiring connections (green and white wires) at keypad and panel terminals.</p>
No sound coming from speakers	<p>Check for correct wiring connections at keypad and panel terminals.</p>

## Specifications

Compatibility	Concord 4
Power requirements	12 VDC nominal
Current - 110 mA	Maximum alarm current
Current - 60 mA	Typical operation
Current - 23 mA	Power saving mode (no panel AC power)
Operating temperature	32° to 120°F (0° to 49°C)
Storage temperature	-4° to 140°F (-20° to 60°C)
Humidity	95% relative, non-condensing
Dimensions	5.32" x 6.03 x .092" (L x W x D)

## Regulatory Information

Manufacturer	UTC Fire & Security Americas Corporation, Inc. 1275 Red Fox Rd., Arden Hills, MN 55112-6943, USA
UL listings	<p>UL 985 Household Fire Warning System Units</p> <p>UL 1023 Household Burglar-Alarm System Units</p> <p>UL1610 Central Station Burglar-Alarm Units (Commercial Burglary)</p> <p><b>Note:</b> See specific panel <i>Installation Instructions</i> for complete UL installation requirements.</p> <p>Not investigated by UL for use as a medical alert.</p>

**FCC Part 15 Information to the User**

Changes or modifications not expressly approved by Interlogix can void the user's authority to operate the equipment.

**FCC Part 15 Class B**

This equipment has been tested and found to comply with the limits for a Class B digital device, pursuant to part 15 of the FCC Rules. These limits are designed to provide reasonable protection against interference in a residential installation.

This equipment generates, uses, and can radiate radio frequency energy and, if not installed and used in accordance with the instructions, may cause harmful interference to radio communications. However, there is no guarantee that interference will not occur in a particular installation.

If this equipment does cause harmful interference to radio or television reception, which can be determined by turning the equipment off and on, the user is encouraged to try to correct the interference by one or more of the following measures:

- Reorient or relocate the receiving antenna.
- Increase the separation between the equipment and receiver.
- Connect the affected equipment and the panel receiver to separate outlets, on different branch circuits.
- Consult the dealer or an experienced radio/TV technician for help.

This Class B digital apparatus complies with Canadian ICES-003.

- Cet appareil numérique de la classe B est conforme à la norme NMB-003 du Canada.
- L'utilisation de ce dispositif est autorisée seulement aux conditions suivantes :  
(1) il ne doit pas produire de brouillage et  
(2) l'utilisateur du dispositif doit être prêt à accepter tout brouillage radioélectrique reçu, même si ce brouillage est susceptible de compromettre le fonctionnement du dispositif.

damages under any theory of liability, whether based in contract, tort, negligence, product liability, or otherwise. Because some jurisdictions do not allow the exclusion or limitation of liability for consequential or incidental damages the preceding limitation may not apply to you. In any event the total liability of Interlogix shall not exceed the purchase price of the product. The foregoing limitation will apply to the maximum extent permitted by applicable law, regardless of whether Interlogix has been advised of the possibility of such damages and regardless of whether any remedy fails of its essential purpose.

Installation in accordance with this manual, applicable codes, and the instructions of the authority having jurisdiction is mandatory.

While every precaution has been taken during the preparation of this manual to ensure the accuracy of its contents, Interlogix assumes no responsibility for errors or omissions.

---

## Contact Information

For general information, see [www.interlogix.com](http://www.interlogix.com). For customer/technical support, see [www.interlogix.com/customer-support](http://www.interlogix.com/customer-support) or call +1 855 286 8889.

© 2015 United Technologies Corporation. Interlogix is part of UTC Building and Industrial Systems, a unit of United Technologies Corporation. All rights reserved.

## Limitation of Liability

To the maximum extent permitted by applicable law, in no event will Interlogix be liable for any lost profits or business opportunities, loss of use, business interruption, loss of data, or any other indirect, special, incidental, or consequential

**Installer: Please provide this page to the end user.**



## Pour Usage avec Concord 4. Testez Votre Système Chaque Semaine.

Guide d'installation # 466-2371, Guide de l'utilisateur # 466-2183

Partielle (Pas Utiliser) Complet Désarmé



F1  
Feu



F2  
Urgence

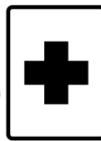

F3  
Police

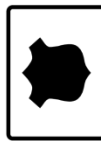

Fermer Partielle Complet



Sans Délai Silencieux



Traits Système Menu

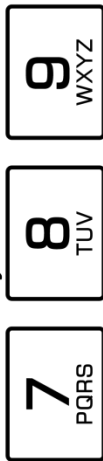

État Lumières Contourner



Sortie Rapide



### Armer Partielle

1. Fermer les portes et fenêtres.
2. Appuyer sur 2 ou Partielle + CODE.
3. En armeture partielle, appuyer sur 4 pour rendre les portes instantané.

### Armer Complet

1. Fermer toutes les portes et fenêtres.
2. Appuyer sur 3 ou Complet + CODE.
3. Sortir par une porte a délai.

### Désarmer

Appuyer sur 1 ou Désarmé + CODE.

### Annuler une Alarme

Appuyer sur 1 ou Désarmé + CODE.

### Contourner une Zone

1. Armer système Partielle ou Complet.
2. Appuyer sur # + CODE + le numero de la zone.

### Activer ou Désactiver le Carillon

1. Désarmer le système.
2. Appuyer sur 7 + 1.

### Allumer/Fermer les Lumières Contrôlée

Appuyer sur 0 + 0.

### Descriptions des Zones

1. \_\_\_\_\_
2. \_\_\_\_\_
3. \_\_\_\_\_
4. \_\_\_\_\_
5. \_\_\_\_\_
6. \_\_\_\_\_
7. \_\_\_\_\_
8. \_\_\_\_\_