

Automatic Environment Control

AEC-2 user manual

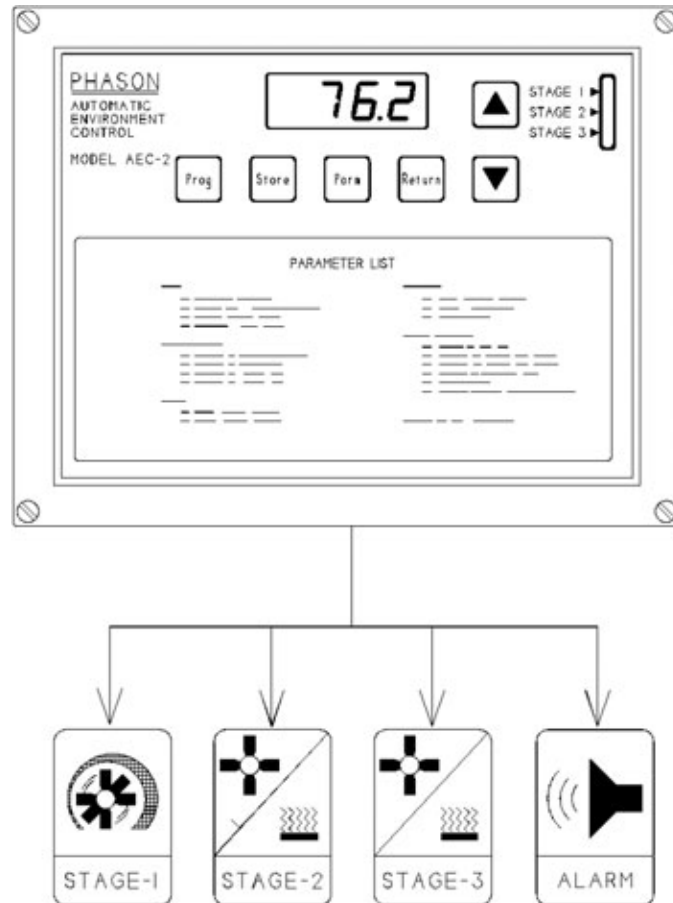

© 2002, Phason Inc.
All rights reserved.

Printed in Canada.
101404 Rev. 3
2002-12-16

LIMITED WARRANTY

This warranty applies only to the Automatic Environment Control (AEC-2). If you need warranty service, return the product and original proof of purchase to your dealer.

Phason Inc. (Phason) warrants this product subject to the following terms and conditions.

This warranty is valid only to the original purchaser of the AEC-2, for two years from the manufacturing date. The manufacturing date is stated in the first eight digits of the serial number in the form year-month-day.

Phason hereby warrants that should the AEC-2 fail because of improper workmanship, Phason will repair the AEC-2, effecting all necessary parts replacements without charge for either parts or labor.

Conditions

- ◆ Installation must be done according to our enclosed installation instructions.
- ◆ The AEC-2 must not have been previously altered, modified, or repaired by anyone other than Phason.
- ◆ The AEC-2 must not have been involved in an accident, misused, abused, or operated or installed contrary to the instructions in our user and/or installation manuals. Phason's opinion about these items is final.
- ◆ The person requesting warranty service must be the original purchaser of the AEC-2, and provide proof of purchase upon request.
- ◆ All transportation charges for products submitted for warranty must be paid by the purchaser.

Except to the extent prohibited by applicable law, no other warranties, whether expressed or implied, including warranties of merchantability and fitness for a particular purpose, shall apply to the AEC-2. Any implied warranties are excluded.

Phason is not liable for consequential damages caused by the AEC-2.

Phason does not assume or authorize any representatives, or other people, to assume any obligations or liabilities, other than those specifically stated in this warranty.

Phason reserves the right to improve or alter the AEC-2 without notice.

Service and technical support

Your dealer will be happy to answer all technical questions that will help you use the AEC-2

Before contacting your dealer or Phason, check the following:

- ◆ Read this manual for information about the feature with which you are having trouble.
- ◆ If you still have a problem with the AEC-2, collect the following information:
 - Model/serial number
 - A description of the problem

My dealer's name: _____

How to contact my dealer:

Street/PO Box _____

City _____

State/Province _____

Zip/Postal _____

Phone _____

Fax _____

E-mail _____

Web site _____



2 Terracon Place
Winnipeg, Manitoba
Canada
R2J 4G7

Phone 204-233-1400
Fax 204-233-3252
E-mail support@phason.ca
Web site www.phason.ca

Table of contents

Features of the AEC-2	1
Getting started	2
AEC-2 electrical ratings	4
Equipment list	5
Getting to know the AEC-2	6
Definition of terms	7
Adjusting the AEC-2	8
Selecting a new operating program	8
Changing parameter settings	9
Setup parameters	11
Programming tips	11
Reloading the factory programs	13
AEC-2 operation	14
Factory program C operation	14
Cutback speed operation	16
Parameter descriptions	18
Parameter ranges	21
Factory programs	22
Methods of use	23
Programs	23
Alert messages	24
Care and maintenance	26
Power factor correction	27
Appendix A - Wiring diagrams	A-1
Appendix B - Self-test procedure	B-1
Appendix C - Troubleshooting guide	C-1
Appendix D - Blank program tables	D-1

Features of the AEC-2

The Automatic Environment Control (AEC-2), is a microprocessor based product designed to efficiently control the environment in livestock buildings. It connects to a variable speed fan, a combination of secondary fans and heaters and an alarm system. When operating, the AEC-2 measures and displays the room temperature. While monitoring the temperature it controls the connected ventilation and heating equipment according to the programmed settings to keep the temperature at the desired point. The program settings can be adjusted in order to change the turn on points and other parameters of the stages. The following is a list of the standard features of the AEC-2.

- Digital display of temperature, alerts and settings
- 8 programs with pre-programmed factory settings which can be easily changed
- A built-in keyboard to allow easy adjustment of settings
- 2 stages of user definable relay contacts to control secondary fans or heaters
- A relay to signal high or low temperature, power interruptions or low line voltage alerts
- Internal memory is retained during power failures
- 115/230 VAC operation @ 12.5 full load amps output for variable speed fan (with RFI noise suppressor to eliminate radio and T.V. interference)
- 3 second full power turn on for variable speed output to minimize fan freeze-up
- Transient protected
- Compact design, 18cm/7" (H) x 23cm/9" (W) x 9.5cm/3.75" (D)
- Non-corrosive, fire retardant enclosure
- 2-year warranty
- Extendable sensor

Getting started

Congratulations on the purchase of your new AEC-2 environment control! This manual has been prepared to help you get the utmost in satisfaction from your AEC-2. It contains detailed information regarding the installation and operation of the control. The Getting Started section will step you through the installation and configuration of your AEC-2. The following steps refer to other sections of this user's guide for additional information. For this reason, it is not necessary to read through the entire document from front to back, but rather in the order that the information is needed.

STEP 1

CHECKING RATINGS OF EQUIPMENT
<ul style="list-style-type: none"><input type="checkbox"/> Read the AEC-2 ELECTRICAL RATINGS on page 4.<input type="checkbox"/> Fill in the EQUIPMENT LIST on page 5. <p>WARNING: The equipment to be connected to the AEC-2 control must not draw more current than what the AEC-2 stages are rated for. Use of equipment that is rated higher than the AEC-2 will result in damage to the control and will void the warranty.</p>

STEP 2

INSTALLATION
<ul style="list-style-type: none"><input type="checkbox"/> Follow the instructions in Appendix A for installing and wiring the AEC-2 and equipment. Be sure to read the General Warnings section in Appendix A before installation.

STEP 3

TESTING
<ul style="list-style-type: none"><input type="checkbox"/> Turn to Appendix B and follow the instructions there to test the operation of the equipment installed and to ensure that it is connected properly.

STEP 4**SETTING UP**

- Read through the ADJUSTING THE AEC-2 section starting on page 8 and get familiar with the programming procedures.
- Configure the AEC-2 according to the type of equipment connected.
- Mark the changes in the Blank Program Tables in Appendix D.

STEP 5**PUTTING CONTROL INTO SERVICE**

- Read the AEC-2 OPERATION section starting on page 14.
- Select the most useful factory program, see page 22.
- Make changes to the program as desired, see page 9.
- Mark the changes in the Blank Program Tables in Appendix D.

STEP 6**METHODS OF USE**

- Read the METHODS OF USE section starting on page 23.



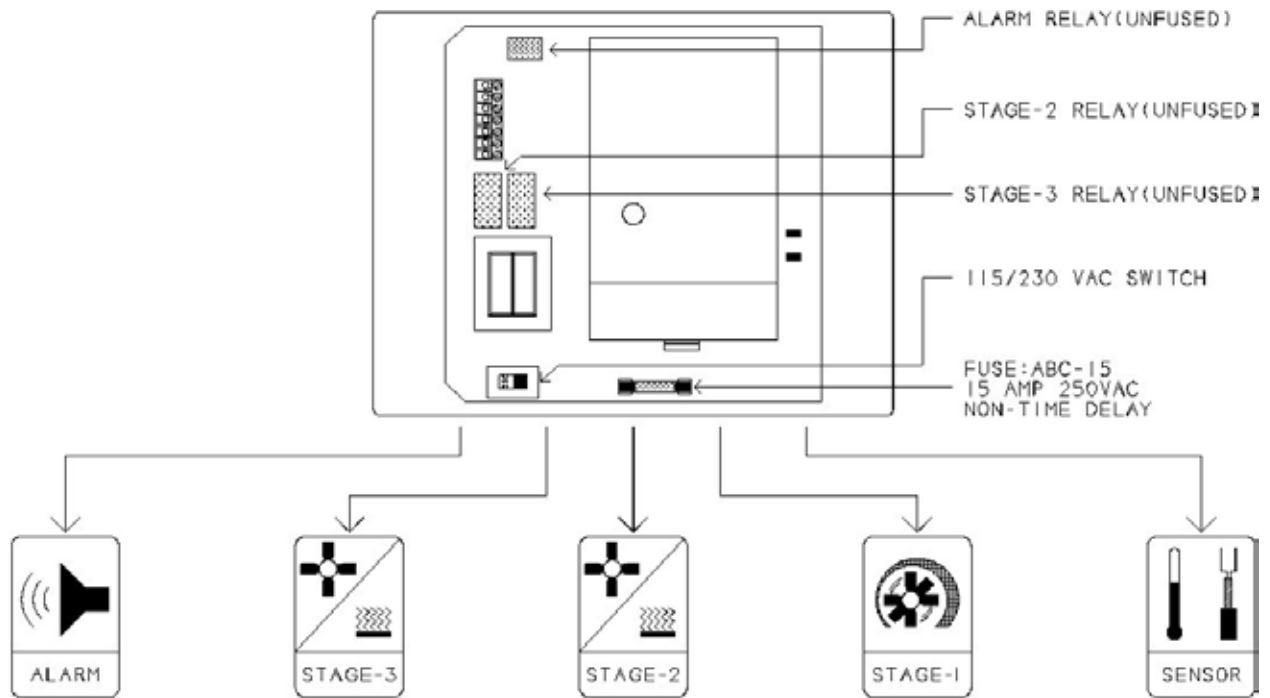

AEC-2 electrical ratings



<p>ALERT RELAY RATINGS: 0.2 Amps, 230 VAC 0.4 Amps, 24 VAC 2 Amps, 30 Vdc for resistive loads</p>	<p>STAGE 3 MAXIMUM RATINGS: 6 FLA at 230 VAC 6 FLA at 115 VAC 360 Watts tungsten</p>	<p>STAGE 2 MAXIMUM RATINGS: 6 FLA at 230 VAC 6 FLA at 115 VAC 360 Watts tungsten</p>	<p>VARIABLE SPEED MAXIMUM RATINGS: 12.5 FLA (full load amps) 115 or 230 VAC</p>	<p>TEMP SENSOR Standard sensor: 30 Feet long.</p>
---	--	--	---	---

NOTE: This is not a wiring diagram. All wiring diagrams are located in Appendix A.

Equipment list

	Variable Speed Stage 1	Make and Model # of fan(s):	
		Max. Total Current Draw of fan(s): Maximum 12.5 FLA. See the Warning section in Appendix A.	
		Operating Voltage:	
	Cool / Heat Stage 2	Make and Model # of fan/heater:	
		Max. Total Current Draw: *	
		Operating Voltage:	
	Cool / Heat Stage 3	Make and Model # of fan/heater:	
		Max. Total Current Draw: *	
		Operating Voltage:	
	Alert	Alert relay connected to:	

* A power contactor must be used if the maximum total current draw is greater than the maximum ratings of the internal relay. See the maximum ratings section on page 4.

Getting to know the AEC-2

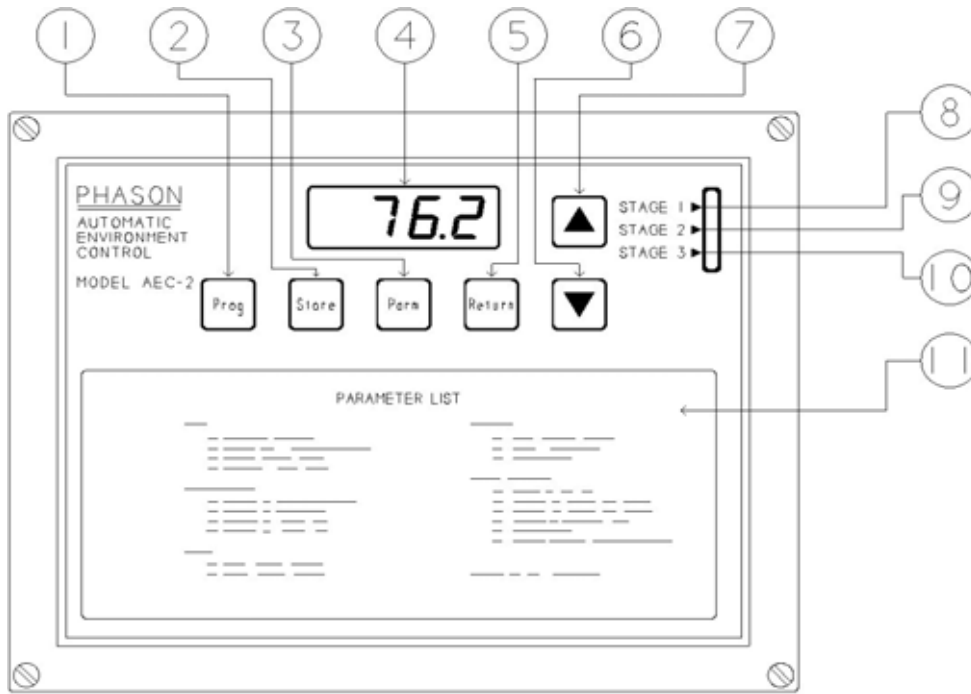

1	PROGRAM button - used to select the desired operating program.	7	UP button -used to increase the value of a parameter.
2	STORE button - used to save selected programs and parameter settings in memory.	8	STAGE 1 indicator light.
3	PARAMETER button - used to scroll through the parameter list.	9	STAGE 2 indicator light.
4	Digital display - shows the temperature and settings.	10	STAGE 3 indicator light.
5	RETURN button - used to return back to normal operation.	11	Complete parameter list.
6	DOWN button - used to decrease the value of a parameter.		

Definition of terms

NORMAL OPERATION The AEC-2 is in normal operation when it is displaying the room temperature. When alerts occur, the display will alternately flash the alert message and the room temperature.

PROGRAMS Programs consist of Main, Differential, Alerts and General parameters. The AEC-2 has eight programs which can be selected and reprogrammed by the user.

OPERATING PROGRAM The AEC-2 operates according to the parameters in the operating program. Any one of the programs may be selected as the operating program.

PARAMETER LIST The parameter list is printed on the front of the AEC-2 and also shown on page 21. It is a list of all the parameters that may be programmed by the user.

PARAMETERS Parameters are the individual settings which may be programmed. Read the PARAMETER DESCRIPTIONS section on page 18 for an explanation of each parameters. There are five parameter categories.

- 1) Main - The MAIN parameters control the main operation of the control.
- 2) Differential - These parameters are programmable differentials. They are the number of degrees above or below the temperature set point the particular stage starts or turns on.
- 3) Alerts - These parameters set the point at which the temperature alerts activate.
- 4) General - GENERAL parameters are common to all programs. These parameters can have only one setting which is the same in all programs.
- 5) Setup - SETUP parameters control the overall operation of the unit. These parameters have only one setting which is the same in all programs.

Adjusting the AEC-2

Selecting a new operating program

As livestock matures, often a change in the room climate is needed. The AEC-2 has eight different programs in memory for eight different climate settings. Any one of the programs can be chosen as the operating program. In order to change the operating program of the AEC-2, follow the instructions listed below. For a list of the factory settings in the programs see Table 2, on page 22.

- 1) Press the **PROG** button once.

The AEC-2 will display the current operating program, (A, b, C, d, E, F, g or H). The display will flash the program name and Pr.



- 2) Press the **PROG** button a number of times until the desired program is displayed.

By pressing the **PROG** button, the program names are displayed one after another. To change to a different operating program, press the **PROG** button until the proper program is displayed.



- 3) Press the **STORE** button to enter the desired program into memory.

When the correct program is displayed, pressing the **STORE** button will tell the AEC-2 to use the selected program as the operating program. After **Stor** is displayed, the AEC-2 returns to normal operation.



Changing parameter settings

Follow the steps below to view and/or edit the parameters in any program. After the parameters have been edited, the changes should be marked in the Blank Program Tables in Appendix D for future reference.

- 1) Press the **PROG** button until the program that you want to edit is displayed.

The display will flash the program letter, (A to H) and Pr.

NOTE: If the operating program is to be edited, step 1 may be skipped. The parameters of the operating program will be displayed by default.

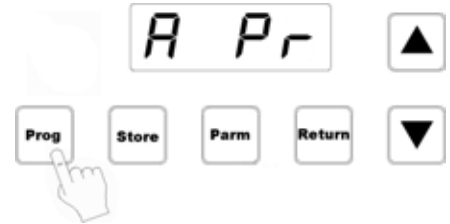

- 2) Press the **PARM** button once.

The first (left most), digit shows the program that is being edited.

The second digit indicates if the program is the operating program. An o means the program is the operating program, a blank means it is not the operating program.

The two right most digits show the parameter number to be edited.



- 3) Press the **UP** or **DOWN** key to turn memory protect off.

The display will show **A o 0** and then **°FF** indicating memory protect has been turned off. The parameters can now be adjusted. If memory protect is not turned off, the parameters can only be viewed. Attempting to adjust the parameters while memory protect is on will result in an **Err** message being displayed.

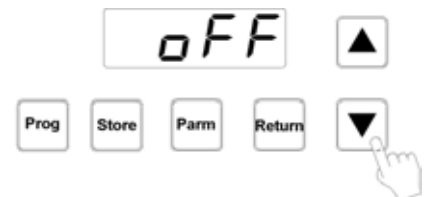

- 4) Press the **PARM** button to step through the parameter list until the desired parameter is reached.
Refer to the front cover of the AEC-2 control or Table 1 on page 21 for the parameter list.



- 5) Use the **UP / DOWN** buttons to adjust the setting.

The parameter can be adjusted to any value within the valid range. The ranges are shown on page 21.



- 6) Press **STORE** to save the setting in memory.

The display will show **Stor** for 1 second indicating the new setting has been stored in memory. If the **PARM** button is pressed before pressing **STORE** the next parameter will appear and the previous one will change back to its previous setting.



Continue through the parameter list by pressing the **PARM** button and making changes to the settings where needed. Follow the same procedure shown in steps 4 to 6 above.

- 7) To return to normal operation (displaying of room temperature) at any time, press the **RETURN** button.
When **RETURN** is pressed, memory protect is automatically turned back on. If a parameter has been changed but the value has not been stored, pressing **RETURN** will change the parameter's setting to the last stored setting and then press **RETURN** again to return to normal operation.



NOTE: If the AEC-2 is left displaying a parameter it will revert back to normal operation in 1 minute automatically. If **STORE** was not pressed the displayed parameter will change back to its previous value.

Setup parameters

The setup parameters should be programmed when the installation has been completed to configure the AEC-2, and then generally the parameters do not need to be reprogrammed. These parameters are different than the other parameters because they can have only one setting and cannot be edited in the normal way. Each setup parameter setting is common to all programs. Follow the instructions below to access the setup parameters.

When the setup parameters have been programmed the blank program table in Appendix D should be filled in with the new settings for future reference. It is important that the Configuration decal, included with the AEC-2, is marked correctly and affixed to the side of the AEC-2 when the setup parameters have been programmed. The Configuration decal provides a handy reference when you need to check the mode of operation of the staged outputs.

To Edit the Setup Parameters

Press the PARM button once to enter the edit mode. If you wish to edit the setup parameters, you must turn off memory protect now. See page 9 to turn off the memory protection.

Next press the PROG and PARM buttons simultaneously to access the setup parameters. The Setup parameters can be adjusted as desired and stored in the same way the normal parameters can. After the setup parameters have been changed and stored, press the RETURN button to return to normal operation.



Programming tips

Scrolling Backwards

When viewing or editing the parameters, sometimes it is helpful to scroll backwards through the parameter list. To do this, press the PARM and UP buttons simultaneously. Instead of the AEC-2 displaying the next parameter on the list, it will display the previous parameter.



Selecting a Parameter to Edit

The parameters are stored in a table in memory which is similar to the Factory Program Table on page 22. Any parameter in any program can be edited when memory protection has been turned off. Follow these procedures when editing parameters to become more efficient.

To move down to the next parameter press the PARM button.

To move up or backwards to the previous parameter press the PARM and UP buttons simultaneously.

To move right press the PROG button until the desired program is displayed, then press the PARM button once to edit the same parameter number that was being edited before.

To Move	Button(s)
↓	PARM
↑	PARM and UP
→	PROG

An example where this method of programming is useful would be a situation where the temperature set point of each program needs to be changed. This could be done by turning off memory protection and changing the temperature set point in the operating program, (the operating program is displayed with an o and the program name). Then press the PROG button two times to edit the next program. Press the PARM button and edit the parameter. To continue to the next program press the PROG button two times again. Remember that STORE must be pressed after each change to save the new setting in memory.

Fast Editing

When editing the setting of a parameter by adjusting it up or down, hold down either button and then press the other one. This will change the setting ten times faster. If you want to increase the setting, hold down the UP button and then press the DOWN button. The setting will increase ten times faster. To decrease the setting ten times faster, hold down the DOWN button and then press the UP button.



Reloading the factory programs

The factory programs can be reloaded if so desired to replace the existing programs. If the existing programs are not operating properly or need to be changed back to the original factory programs, follow the steps below to reload the factory programs.

When the factory programs are reloaded, all of the existing programs including the setup parameters will be replaced. The AEC-2 will begin with program A as the operating program. The programs and most importantly the setup parameters will need to be reprogrammed for the equipment that is connected. Pay close attention to the configuration of Stages 2 and 3.

- 1) Turn off the power to the AEC-2.
- 2) Hold down the PROG and STORE buttons.
- 3) While holding the buttons down, turn the power back on. The display will flash Stor for two seconds and then the AEC-2 will be in the normal operating mode, displaying the room temperature and a power failure alert.



AEC-2 operation

Factory program C operation

Figure 2 shows the operation of each stage of the AEC-2. This particular diagram shows when the stages will turn on and off if the AEC-2 is operating according to the factory settings in program C. Some settings are listed here but the entire factory program table can be found on page 22. The circled numbers correspond to the parameter numbers. Use these numbers to cross reference the parameters in the diagram to their descriptions.

NOTE: All stages have a programmable hysteresis, parameter 18, which is not shown on the diagram.

PARAMETER SETTINGS

1 Temp Set (Start P-Band)	85.0°F
2 Stage 1 Min Vent	20
3 Cutback Speed	99
4 Stage 1 Off-Set-Back	-5.0
5 Stage 1 P-Band	3.0
6 Stage 2 Turn On	5.0
7 Stage 3 Turn On	-2.0
8 Low Temp Alert	-7.0
9 High Temp Alert	13.0

NOTE: When the variable speed stage turns on, it will run full speed for three seconds and then decrease to the required speed.

EXAMPLE

As an example, say the temperature is 75°F and rising. At this point Stage 3 (heat) will be on and the Low Temperature Alert. When the temperature rises to 78°F the Low Temp Alert will turn off. At 80°F the Stage 1 fan will begin the Off-Set-Back (OSB) region. The Stage 1 fan will run at full speed for three seconds and then slow down to the Minimum Ventilation setting.

When the temperature reaches 83°F Stage 3 (heat) will turn off. At 85°F the Stage 1 P-Band starts. While the temperature rises in the P-Band the Stage 1 fan will increase in speed. At 88°F Stage 1 will reach full speed.

When the temperature rises to 90°F Stage 2 (cool) turns on. At 98°F the High Temperature Alert will turn on.

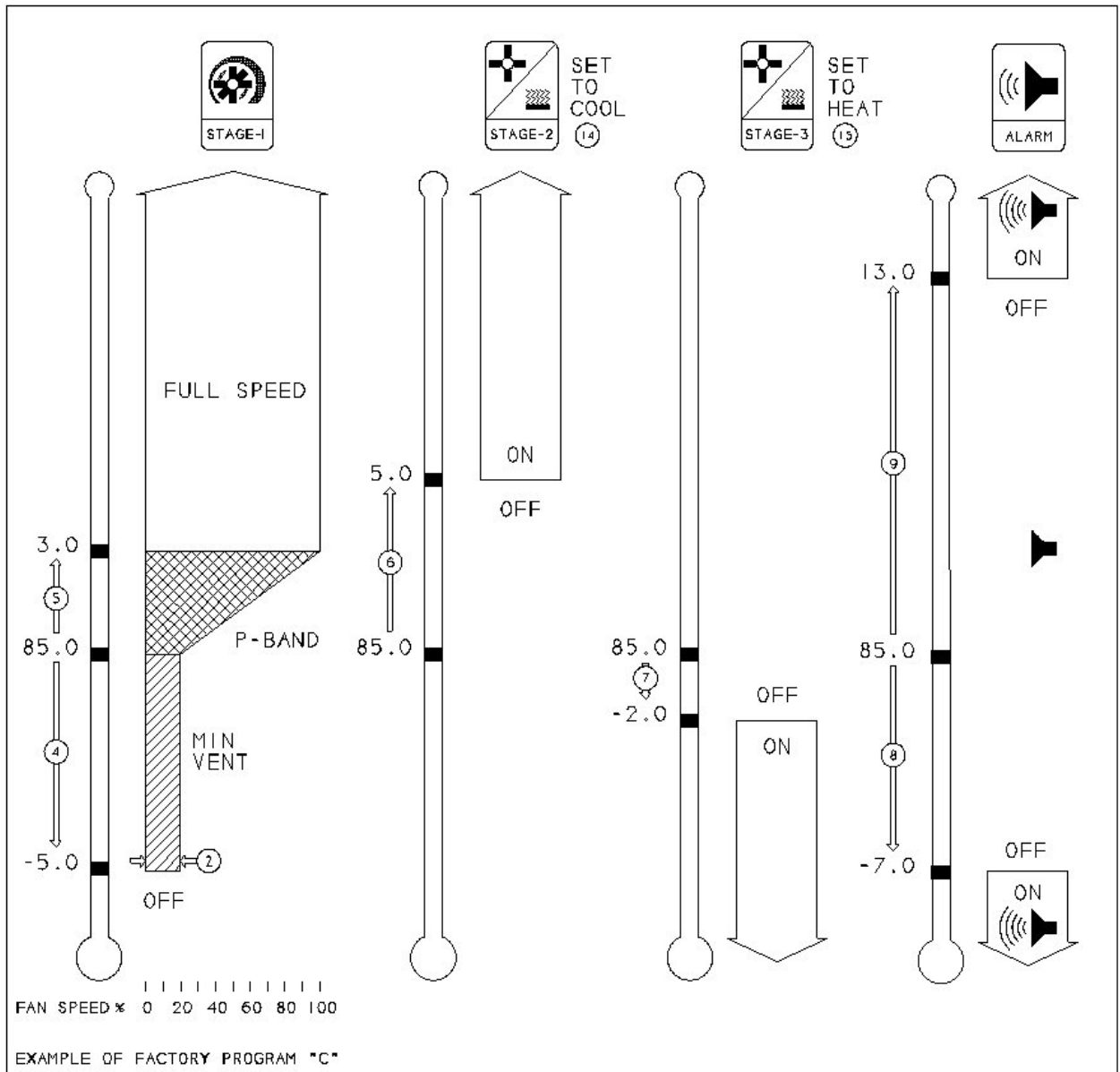

Figure 2: Factory program C operation diagram

Cutback-speed operation

Figure 3 shows the operation of each stage of the AEC-2. This diagram is the same as the one shown in Figure 2 with one exception; parameter 3 has been changed from 99 to 20, (see the parameter settings below). This change causes the speed of the Stage 1 fan to cutback when a ON/OFF stage, that is set to cooling, turns on.

The circled numbers in the diagram correspond to the parameter numbers. Use these numbers to cross reference the parameters in the diagram to their descriptions.

NOTE: All stages have a programmable hysteresis, parameter 18, which is not shown on the diagram.

PARAMETER SETTINGS

1 Temp Set (Start P-Band)	85.0°F
2 Stage 1 Min Vent	20
3 Cutback Speed	20
4 Stage 1 Off-Set-Back	-5.0
5 Stage 1 P-Band	3.0
6 Stage 2 Turn On	5.0
7 Stage 3 Turn On	-2.0
8 Low Temp Alert	-7.0
9 High Temp Alert	13.0

NOTE: When the variable speed stage turns on, it will run full speed for three seconds and then decrease to the required speed.

EXAMPLE

As an example, say the temperature is 75°F and rising. At this point Stage 3 (heat) will be on and the Low Temperature Alert. When the temperature rises to 78°F the Low Temp Alert will turn off. At 80°F the Stage 1 fan will begin the Off-Set-Back (OSB) region. The Stage 1 fan will run at full speed for three seconds and then slow down to the Minimum Ventilation setting.

When the temperature reaches 83°F Stage 3 (heat) will turn off. At 85°F the Stage 1 P-Band starts. While the temperature rises in the P-Band the Stage 1 fan will increase in speed. At 88°F Stage 1 will reach full speed.

When the temperature rises to 90°F Stage 2 (cool) turns on. When Stage 2 turns on Stage 1 will cut back in speed according to the Cutback Speed setting, (parameter 3). This will happen for any stage set for cooling operation. As the temperature continues to rise, the Stage 1 fan will start the P-Band again. The Stage 1 fan will increase in speed and reach full speed again at 93°F.

At 98°F the High Temperature Alert will turn on.

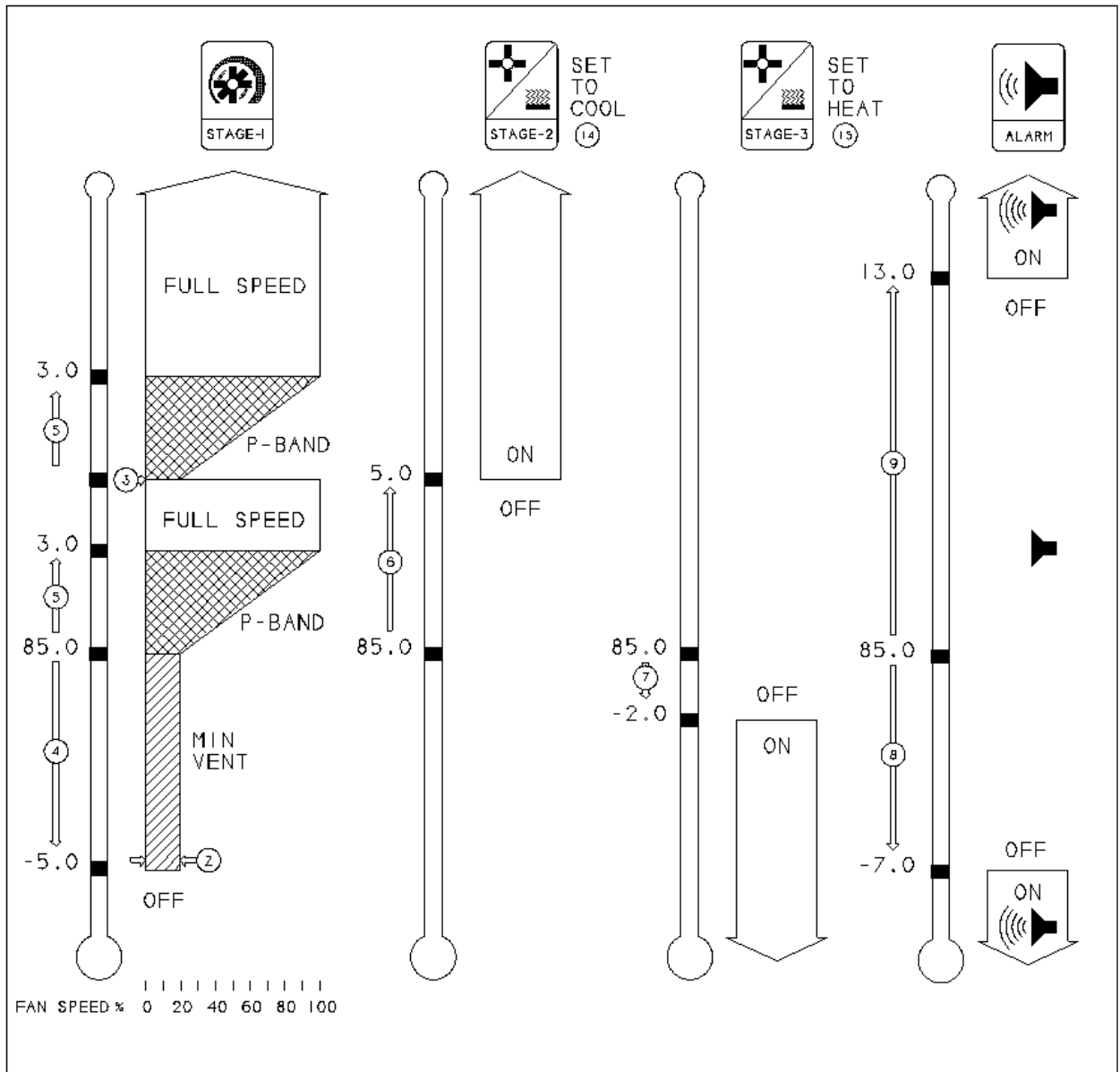

Figure 3: Cutback speed operation diagram

Parameter descriptions

MAIN PARAMETERS

- 0 **MEMORY PROTECTION** [On/Off] - ensures parameters are not changed by accident. Memory protect must be turned off every time the parameters are edited. The memory protect parameter cannot be stored and is turned on automatically when the control is returned to normal operation.
- 1 **TEMPERATURE SET (Start P-Band 1)** [32.0 - 110.0°F, 0.0 - 43.3°C] - is the target room temperature. All differentials and alerts are referenced to this setting. It is the starting point of the Stage 1 P-Band (parameter #6).
- 2 **STAGE 1 MINIMUM VENTILATION** [Minimum Idle (#16) - 99] - is the idle speed in % of full power at which the Stage 1 fan will idle at. It cannot be adjusted below the setting of the Minimum Idle (#16) parameter.
- 3 **CUTBACK SPEED** [Minimum Idle (#16) - 99] - is the speed in % of full power that the Stage 1 fan will slow down to when a secondary cooling stage turns on. It cannot be adjusted below the setting of the Minimum Idle (#16) parameter. When a secondary cooling stage turns on, the Stage 1 fan will slow down to the Cutback Speed setting and then increase in speed as the temperature rises. The Stage 1 fan will be at full speed again when the temperature has risen the amount of the P-Band.

DIFFERENTIALS

- 4 **STAGE 1 OFF-SET-BACK** [IDLE, -20.0 - 0.0°F, -11.1 - 0.0°C] - is a range of degrees below the Temp Set where the Stage 1 fan will be at idle speed, and below this range the fan will be off. Idle means the fan will run at the Min Vent setting at all temperatures below the Temp Set. If Temp Set (#1) is set to 80°F and Stage 1 Off-Set-Back (#4) is set at -8°F the fan will idle when the temperature is between 72°F and 80°F, but will be off below 72°F.
- 5 **STAGE 1 P-BAND** [0.0 - 16.0°F, 0.0 - 8.9°C] - The proportional band is a range of degrees above the Temp Set where the Stage 1 fan increases in speed proportionally to the temperature. If Temp Set (#1), is set to 80°F and Stage 1 P-Band (#5) is set at 5°F the variable speed fan will start to increase speed at 80°F and will be at full speed at 85°F. The P-Band will be restarted when a secondary cooling stage turns on.
- 6 **STAGE 2 TURN ON** [-10.0 - 15.0°F, -5.5 - 8.4°C, OFF] - is the number of degrees above or below the Temp Set at which Stage 2 will turn on. If the Temp Set (#1) is set to 80°F and Stage 2 Turn On (#6) is set to 5°F, Stage 2 will turn on at 85°F. The Stage 2 Operation (#14) parameter regulates what mode Stage 2 operates in, heat or cool.
- 7 **STAGE 3 TURN ON** [-10.0 - 15.0°F, -5.5 - 8.4°C, OFF] - is the number of degrees above or below the Temp Set at which Stage 3 will turn on. If the Temp Set (#1) is set to 80°F and Stage 3 Turn On (#7) is set to -5°F, Stage 3 will turn on at 75°F. The Stage 3 Operation (#15) parameter regulates what mode Stage 3 operates in, heat or cool.

ALERTS

- 8 LOW TEMPERATURE ALERT** [OFF, -36.0 - 0.0°F, -20.0 - 0.0°C] - is the number of degrees below the Temp Set that a low temperature alert will be generated, (**A Lt**). This alert may be disabled by adjusting it to OFF.
- 9 HIGH TEMPERATURE ALERT** [0.0 - 36.0°F, 0.0 - 20.0°C, OFF] - is the number of degrees above the Temp Set that a high temperature alert will be generated, (**A Ht**). This alert may be disabled by adjusting it to OFF.

GENERAL PARAMETERS

General parameters have one setting common to all programs. When they are changed in one program, they change in all of the programs.

- 10 LOW POWER ALERT** [ON - OFF] - When the line voltage drops below the proper operating level, a low power alert will be displayed (**A LP**). This alert may be disabled by adjusting it to OFF. When disabled, the display will still flash **A LP** but the alert relay will not activate.
- 11 ALERT LATCHING** [ON - OFF] - When this parameter is turned ON, all alerts will be displayed on the AEC-2 and will continue to flash after the alert condition is gone. They can be reset by pressing the RETURN button. This feature is useful to keep track of the alerts that occur during times when the control is not being supervised. For example; in the morning the AEC-2 could be checked for alerts that occurred during the night and then the alerts could be cleared. If this parameter is turned OFF, the display will only show the alert when the condition is present. When the alert condition is gone, the alert will no longer be displayed.
- 12 VENTILATION** [ON - OFF] - When this parameter is turned OFF, the variable speed outputs and cooling stages are turned off completely and all alerts will not be displayed. The heating stages are not affected. Ventilation may be turned OFF when a room is vacant to conserve energy. When it is turned OFF the AEC-2 will display **V°F**. DO NOT use this to shut down fans to work on the fans or electrical wiring. Ensure the breakers are turned off.

SETUP

The setup parameters are common to all programs and can only have one setting. They cannot be accessed by the same procedure as the normal parameters. This has been done to protect these parameters from accidentally being changed. Follow the instructions on page 11 to program these parameters.

- 13 TEMPERATURE UNITS** [°F - °C] - This parameter programs the AEC-2 to display temperature in degrees Fahrenheit or degrees Celsius.
- 14 STAGE 2 OPERATION** [HEAT - COOL] - This parameter programs the Stage 2 output to operate as a heating stage or a cooling stage. When it is set to HEAT, the stage will be on below the Stage 2 Turn On (#6). If it is set to COOL, the stage will be on above the Stage 2 Turn On (#6).
- 15 STAGE 3 OPERATION** [HEAT - COOL] - This parameter programs the Stage 3 output to operate as a heating stage or a cooling stage. When it is set to HEAT, the stage will be on below the Stage 3 Turn On (#7). If it is set to COOL, the stage will be on above the Stage 3 Turn On (#7).
- 16 STAGE 1 MINIMUM IDLE** [0 - 99] - This is the minimum idle preset in percent of full speed. The Stage 1 Min Vent (#2) and Cutback Idle (#3) cannot be adjusted below this setting. For example; if it is programmed to 20 the Stage 1 Min Vent (#2) parameter cannot be adjusted below 20. It is recommended that this parameter be programmed to correspond to the lowest speed at which the motor can still operate.
- 17 STAGE 1 POWER FACTOR COMPENSATION** [0.5 - 2.5] - This is set at the factory to 1.0 and should only be adjusted if the Stage 1 variable speed fan does not operate properly with the AEC-2.
- 18 HYSTERESIS** [0.5 - 2.5°F, 0.3 - 1.4°C] - This is the number of degrees of difference between the turn-on point and turn-off point for all stages. It is the number of degrees above the turn-on point that a heating stage will turn off, and the number of degrees below the turn-on point that a cooling stage will turn off.

Parameter ranges

#	PARAMETERS	RANGES	
		°F	°C
	MAIN		
0	Memory Protection	ON / OFF	
1	Temp Set (Start P-Band)	32.0 to 110.0	0.0 to 43.3
2	Stage 1 Min Vent	Min Idle (parm #16) to 99 %	
3	Cutback Speed	Min Idle (parm #16) to 99 %	
	DIFFERENTIALS		
4	Stage 1 Off-Set-Back	IDLE, -20.0 to 0.0	IDLE, -11.1 to 0.0
5	Stage 1 P-Band	0.0 to 16.0	0.0 to 8.9
6	Stage 2 Turn On	-10.0 to 15.0, OFF	-5.5 to 8.4, OFF
7	Stage 3 Turn On	-10.0 to 15.0, OFF	-5.5 to 8.4, OFF
	ALERTS		
8	Low Temp Alert	OFF, -36.0 to 0.0	OFF, -20.0 to 0.0
9	High Temp Alert	0.0 to 36.0, OFF	0.0 to 20.0, OFF
	GENERAL		
10	Low Power Alert	ON / OFF	
11	Alert Display Latching	ON / OFF	
12	Ventilation	ON / OFF	
	SETUP		
13	Units °F or °C	°F / °C	
14	Stage 2 Operation	HEAT / COOL	
15	Stage 3 Operation	HEAT / COOL	
16	Stage 1 Minimum Idle	0 to 99 %	
17	Stage 1 P.F. Compensation	5 to 25	
18	Hysteresis	0.5 to 2.5	0.3 to 1.4

Table 1: Adjustable ranges of the parameters

Factory programs

The AEC-2 is preprogrammed with the factory settings as shown below. See the GETTING TO KNOW THE AEC-2 section for instructions for selecting a program. Select the most useful program and make changes where necessary.

#	PARAMETERS	PROGRAM NAMES (A-H)							
		A	b	C	d	E	F	g	H
	MAIN								
1	Temp Set (Start P-Band)	95	90	85	80	72	70	65	60
2	Stage 1 Min Vent	20	20	20	20	20	20	20	20
3	Cutback Speed	99	99	99	99	99	99	99	99
	DIFFERENTIAL								
4	Stage 1 Off-Set-Back	-3	-3	-5	-5	-5	-5	-5	-3
5	Stage 1 P-Band	3	3	3	5	5	5	8	8
6	Stage 2 Turn On	5	5	5	7	7	7	10	10
7	Stage 3 Turn On	-1	-1	-2	-2	-2	-2	-2	-2
	ALERTS								
8	Low Temp Alert	-3	-3	-7	-10	-15	-15	-15	-10
9	High Temp Alert	6	8	13	18	23	25	30	35
	GENERAL								
10	Low Power Alert					ON			
11	Alert Display Latching					ON			
12	Ventilation					ON			
	SETUP								
13	Temperature Units					°F			
14	Stage 2 Operation					COOL			
15	Stage 3 Operation					HEAT			
16	Stage 1 Minimum Idle					20			
17	Stage 1 P.F. Compensation					10			
18	Hysteresis					0.5			

Table 2: Factory Programs

Methods of use

Programs

The AEC-2 has eight programs from which one can be selected as the operating program. To take advantage of the programs, adjust them for different climate settings. They could be used for different kinds of livestock or used at different stages of maturity of the particular livestock. Time is saved by simply changing the program, instead of adjusting every parameter. Remember to mark all changes to the programs in the Blank Program Tables in Appendix D to keep track of the settings.

Alert messages

ALERT	DESCRIPTION
Err	Error - an incorrect key has been pressed
R Ht	Alert H igh Temperature - temperature is above the high temp alert setting
R Lt	Alert L ow Temperature - temperature is below the low temp alert setting
R LP	Alert L ow P ower - the line voltage is low
R Pd	Alert P robe D isconnect - the temperature sensor is disconnected
R PS	Alert P robe S hort - the temperature sensor is short circuited
R PF	Alert P ower F ailure - indicates a power interruption has occurred
R IE	Alert I nternal E rror - indicates an internal error has occurred
UoFF	Ventilation O ff - ventilation has been turned off in the program

REASONS FOR ALERTS TO ACTIVATE

Err	The Err message appears when an incorrect key has been pressed or if an attempt has been made to change a parameter while memory protect is on. The Err message will appear for 2 seconds and then disappear.
A Ht	The high temperature alert appears when the room temperature is above the high temperature alert setting (parameter #9). Check if the fans are operating properly. This alert may occur on very hot days when the desired room temperature cannot be maintained.
A Lt	The low temperature alert appears when the room temperature is below the low temperature alert setting (parameter #8). Check if the heater is operating properly.
A LP	The low power alert turns on when the line voltage drops below 180 for 230 VAC operation or below 90 for 115 VAC operation. This indicates a problem with the electrical service of the building. The control may operate erratically if the voltage drops below these levels.
A Pd	This indicates the temperature sensor is disconnected. The sensor wire may be broken or damaged somewhere.
A PS	This alert indicates the temperature sensor is short circuited. The sensor or wire may be damaged somewhere.
NOTE: When a A Pd or a A PS alert occurs, the heating and cooling stages will turn off and the variable stages will run at idle speed.	
A PF	The Power Failure alert appears when there has been an interruption in the power. The control will continue operating properly and the alert can be cleared by pressing the RETURN button.
A IE	When this alert appears it indicates an internal error has occurred. To clear this alert check through the parameters; adjust and store the ones that are incorrect. Next, turn the power off and then back on and the alert will be cleared. NOTE: A parameter must be changed and stored and the power turned off and on before the alert will be cleared. Another way to clear the alert is downloading the factory programs. This will reset all the parameters to the factory settings and then they must be programmed to the desired settings again. Consult your dealer or Phason for information to prevent this problem from happening again.
UoFF	V°FF is displayed when VENTILATION (parameter #12), is turned OFF. When this is displayed, the variable speed stages and the cooling stages will be turned off. The heating stage(s) will operate normally.

Care and maintenance

Moisture will not cause a problem with the control if the proper care is taken in installation. The control's enclosure is made of fire retardant plastic and is sealed with a rubber gasket. The sensor entry is sealed with a liquid tight cable connector.

Caution should be taken when washing the room with a high pressure washer. **DO NOT** direct a high pressure washer at the control. In order to clean the control, wipe it with a damp cloth.



Be sure the power is off before cleaning to avoid electrical shock.

MAINTENANCE

- To prevent damage to the control, after the first two weeks of operation remove the cover from the unit and check for moisture inside. Be sure to turn off the power to the control before opening the cover.
- If moisture is present, wipe it out with a dry cloth and check the cable entry points and rubber gasket for proper sealing.
- If the cable connectors are not sealing, apply RTV or Silicon II sealant around the cable.
- **WARNING:** If a sealant is used, be aware that some silicone sealants release acetic acid while curing. This can cause corrosion damage to the control. Let silicone cure completely (1 to 3 days), before closing the control or the control may be damaged and the warranty VOID.
- Check the control again after two weeks to ensure that it is properly sealed.
- The control should be opened and inspected once a year for moisture. Proper care and maintenance will extend the life of the control.

Power factor correction

Adjusting the P-Band to correct for a particular power factor may improve your ventilation system's performance. Power factor correction is generally unnecessary and there is no danger of damage being done to the control or motor if it is not done. As a result of different power factors between the many makes and models of fan motors, the actual P-Band may be less than the P-Band setting displayed by the control.

If the power factor of the motor is available, use the chart of correction numbers, (listed in the table below), and CALC 1 below to calculate the P-Band setting required in order to get the desired P-Band. A power factor of 0.8 or greater will cause an insignificant change to the P-Band and does not need to be corrected.

CALC 1:

P-BAND SETTING = DESIRED P-BAND x CORRECTION NUMBER

Example 1:

To have a 6°F P-Band with a motor which has a power factor of 0.7, set the P-Band to 7.5°F. ie. 6°F x 1.25 = 7.5°F

POWER FACTOR	CORRECTION NUMBERS
1.0	1.00
0.9	1.05
0.8	1.10
0.7	1.25
0.6	1.33
0.5	1.60

If the power factor is not known the correction number may be measured. Follow the steps below.

- 1) Set the Minimum Ventilation parameter, (#2) to the desired value.
- 2) Set the P-Band to 10°F, parameter # 5.
- 3) Observe the ROOM TEMPERATURE.
- 4) Adjust the TEMP SET, (#1) to equal the ROOM TEMPERATURE. Now, the Stage 1 fan will be running just above minimum ventilation.
- 5) Slowly decrease the TEMP SET, (parameter # 1) and listen to the fan increase in speed.
- 6) Observe the TEMP SET, (**FULL SPEED TEMP SET**) at which the motor reaches full speed.
- 7) Calculate the Correction number for the motor as follows:

CALC 2:

$\frac{10^{\circ}\text{F}}{\text{FULL SPEED TEMP SET} - \text{ROOM TEMPERATURE}} = \text{Correction number}$

Example 2: ROOM TEMP = 75°F and FULL SPEED TEMP SET = 82°F

Correction Number = $\frac{10^{\circ}\text{F}}{82^{\circ}\text{F} - 75^{\circ}\text{F}} = 1.43$ Now use CALC 1 above to find the P-Band setting.

Appendix A - Wiring diagrams

Installation overview	A-2
General warnings	A-3
Mounting instructions	A-4
Grounding and sealing	A-4
230 VAC control and stage 1	A-5
115 VAC control and stage 1	A-5
Temperature sensor	A-6
4-zone averaging	A-6
Manually extending sensor	A-7
Alert siren installation	A-8
Alarm panel installation	A-8
230 VAC heat/cool stages	A-9
115 VAC heat/cool stages	A-9
Heat/cool stage furnace	A-10
Heat/cool bypass switch	A-11
Variable stage bypass switch	A-11

Installation overview

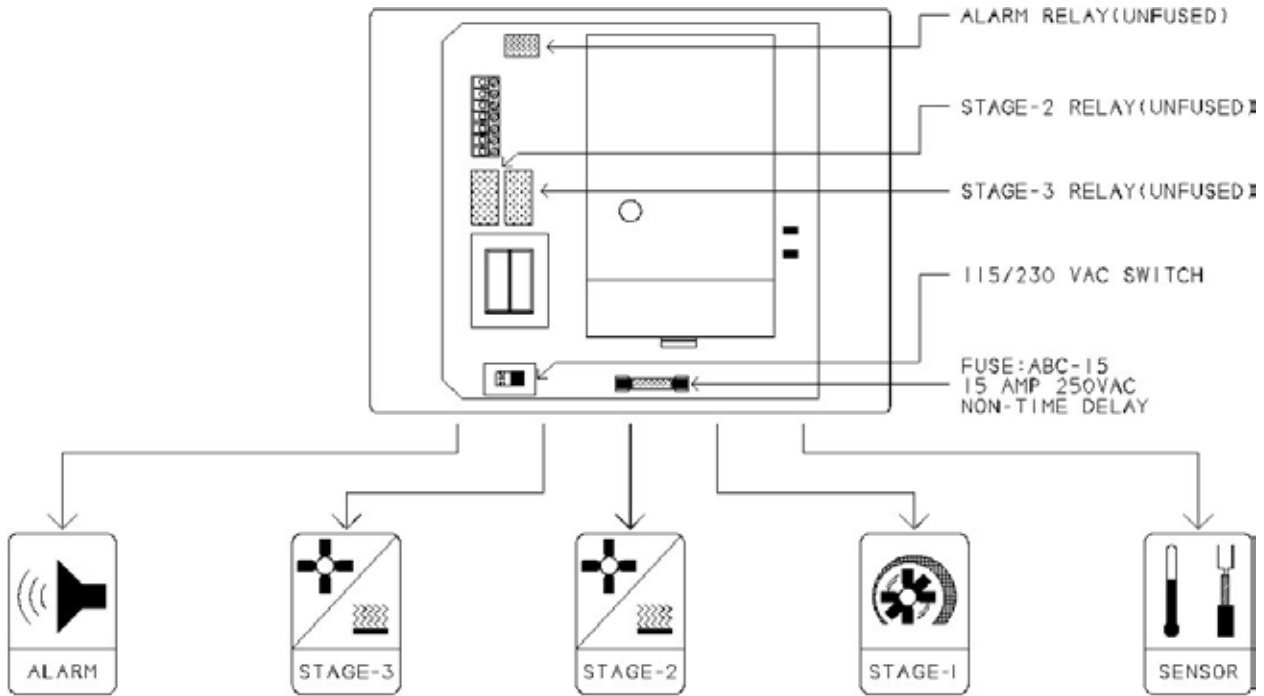

ALERT RELAY	STAGE 3	STAGE 2	VARIABLE SPEED	TEMP SENSOR
Page A-8	Pages A-9 A-10	Pages A-9 A-10	Page A-5	Pages A-6 A-7

Wiring diagrams and instructions for the different stages are located on the pages listed above. First read the General Warnings and Mounting Instructions sections, then follow the instructions given for each stage.

General warnings



BE SURE POWER IS OFF BEFORE DOING ANY WIRING.

Install all equipment according to the applicable local electrical codes.

Most variable speed fan motors draw more current at fractional speeds than at full speed. Fan motor specifications show current draw at full speed. The increase in current draw may be as much as two times the rated current. Current over 12.5 Amps will cause overheating and eventual failure of the AEC-2. Please check current requirements for the fan motor by either measuring current draw at all speeds from idle to full speed or consult the dealer for information on the particular fan.

CAUTION: Stages 1 and 2 are for control of shaded pole, permanent split capacitor or universal motors only.

DO NOT mount power contactors inside the AEC-2 enclosure. Power contactors create electrical noise which may cause the AEC-2 to work improperly.

Warning: Phason controls are designed and manufactured to provide reliable performance, but they are not guaranteed to be 100% free of defects. Even reliable products may experience occasional failures, and this possibility should be recognized by the User. If Phason products are used in a life support ventilation system where failure could result in loss or injury, the user should provide adequate back-up ventilation, supplementary natural ventilation or an independent failure alarm system. The user's lack of such precautions acknowledges their willingness to accept the risk of such loss or injury.

A false 'A PF' alarm is due to electrical noise caused by high voltage transients in certain installations. Electrical noise varies according to the type of equipment installed, the wiring layout and many other factors. Its effects are not apparent in most installations but over time it can cause degradation of electronic circuits and of relays and power contactors. These transients can cause unreliable operation of your equipment if they are not properly controlled. Therefore, snubbing filters must be installed on all inductive loads for installations of this type. The filters must be connected in parallel with the load so the snubbing filter may absorb the transient energy.

PHASON has snubbing filters available for different types of equipment.

Mounting instructions

To mount the AEC-2, remove the four screws in the front cover and lift off the cover. The cover can be unplugged from the bottom to make wiring easier. Mount the box to the wall with the four wood screws provided with the control. Insert the screws into the large holes in each corner of the box and tighten.

Use the knockouts provided at the bottom of the enclosure for mounting cable connectors. **DO NOT** make additional holes in the enclosure. This should not be done and will void the warranty! All wires should enter the enclosure through the electrical-knockout holes provided and all grounds should be connected to the ground plate. When installing a control, close attention should be taken to route the wires, inside the control, away from the control's electronics so that wires are not draped across the components which may result in a part being broken or damaged which will affect the reliability of your control.

DO NOT mount the bottom enclosure rotated 180° which places the electric-knockouts at the top of the enclosure. This should not be done and may void warranty! When this is done corrosion causing moisture is more likely to enter the control and wiring will be prone to contact with the electronic circuitry which may cause damage to components as stated above.

Grounding and sealing



- A - Connect all ground wires to ground studs.
- B - Use 3/4" liquid tight wire connectors for large holes.
- C - Use 1/2" liquid tight wire connectors for small holes.
- D - Use RTV silicone or Silicon II sealant to seal cable entry points if liquid tight wire connectors are not used.

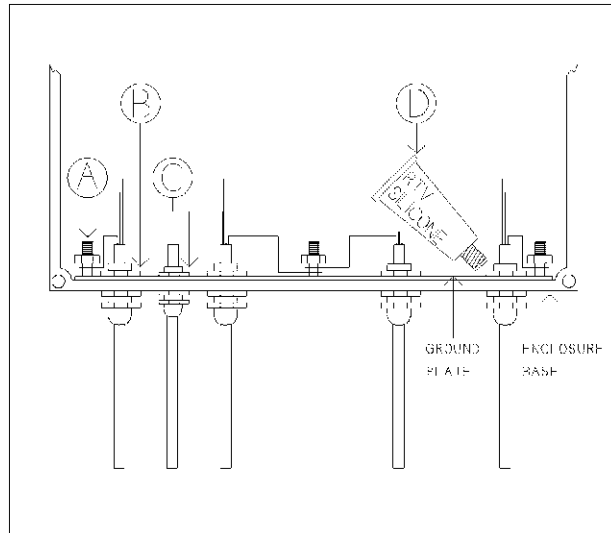

If silicone is used, be aware that some silicone sealants release acetic acid while curing. This can cause corrosion damage to the control. Let silicone cure completely (1 to 3 days), before closing the control or the control may be damaged and the warranty VOID

230 VAC control and stage 1



Connect the power mains to the BLACK and WHITE wires. Connect the variable speed fan to the BLUE and WHITE wires.

A - Set voltage selector switch to the 230 VAC position.

B - Stage 1 fuse type: 15 Amp, 250 VAC ceramic fuse.

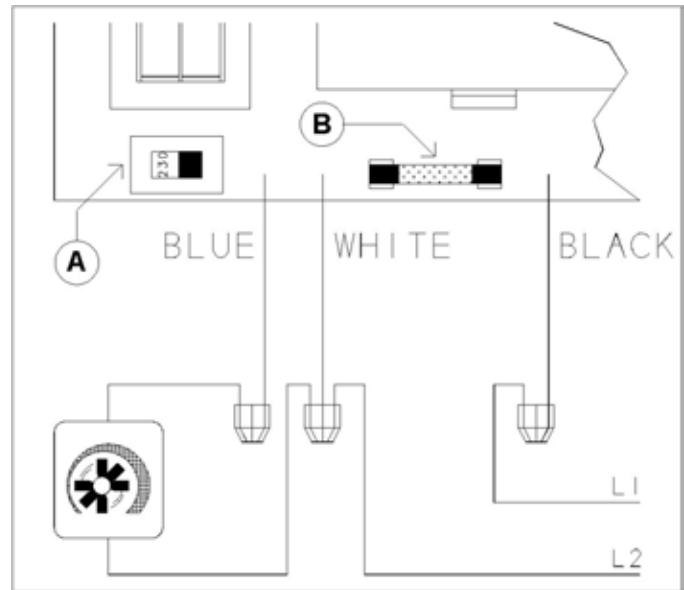

Wire according to applicable local electrical codes.

115 VAC control and stage 1

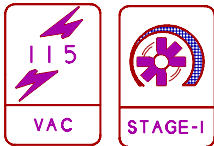

Connect the power mains to the BLACK and WHITE wires. Connect the variable speed fan to the BLUE and WHITE wires.

A - Set voltage selector switch to the 115 VAC position.

B - Stage 1 fuse type: 15 Amp, 250 VAC ceramic fuse.



Wire according to applicable local electrical codes.

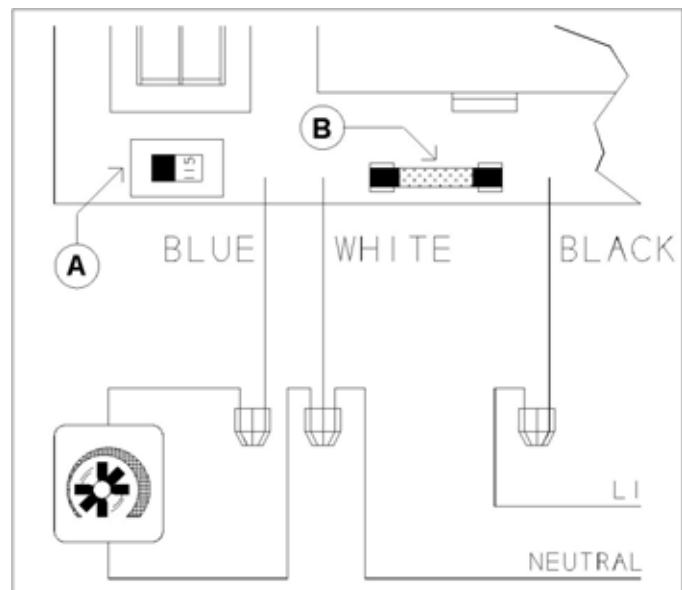

Temperature sensor

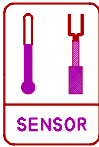

Connect the sensor to terminals 4 and 5.

A) The temperature sensor can be extended if so desired. An extended sensor can be ordered from PHASON. To manually extend the sensor, follow the instructions on page A-7.

When installing the extended sensor, do not run the cable next to other power cables and when crossing over other cables, cross at 90°.

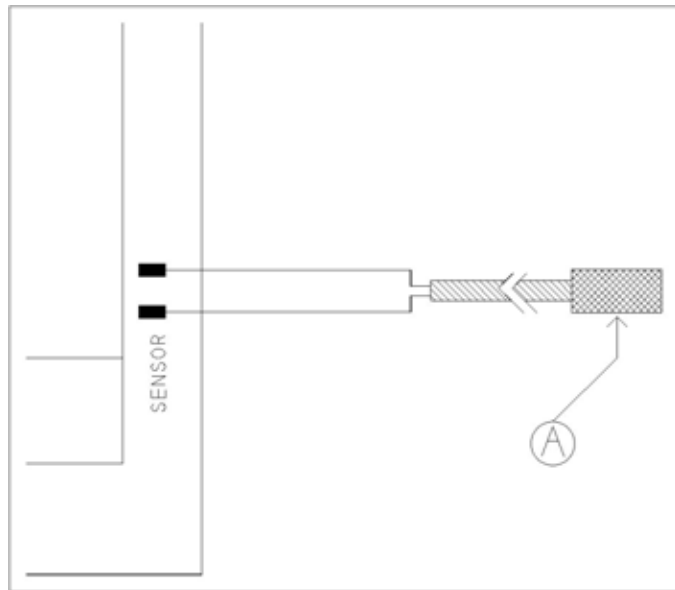

4-zone averaging

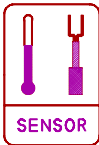

Connect the sensor to terminals 4 and 5.

The AEC-2 is capable of monitoring the temperature in four areas and operating accordingly to the average. To take advantage of this option, you must connect four temperature sensors to the unit. To manually extend the sensor, follow the instructions on page A-7.

A) The AEC-2 can operate with one or four probes connected.

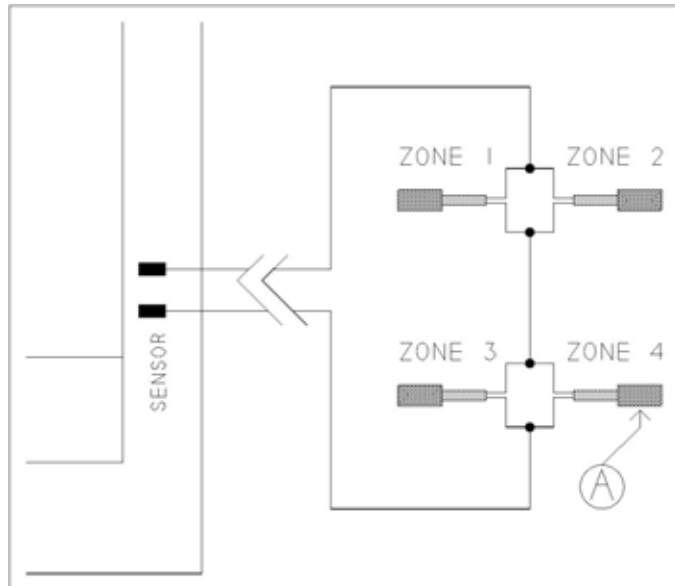

Manually extending the sensor

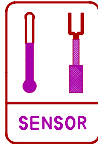

To extend the sensor, use 2 wire 18 or 20 AWG jacketed cable. To splice two wires together follow the steps below and refer to the diagram.

A) Slide pieces of heat shrink tubing on the wire ends as shown.

B) Strip the ends of wire and twist together.

C) Using a soldering iron and solder, connect the twisted wire ends together.

D) Slide the heat shrink tubing over the soldered connection.

E) Heat tubing with a hot air gun (paint stripper).

F) When finished, the splice should be completely sealed.

NOTE: If the unit operates erratically with the extended sensor, try running the extended sensor on a different path or shortening it. Check to be sure that the sensor cable is not run alongside other electrical wires or near electrical equipment. When crossing electrical wires, it is best to cross at 90°

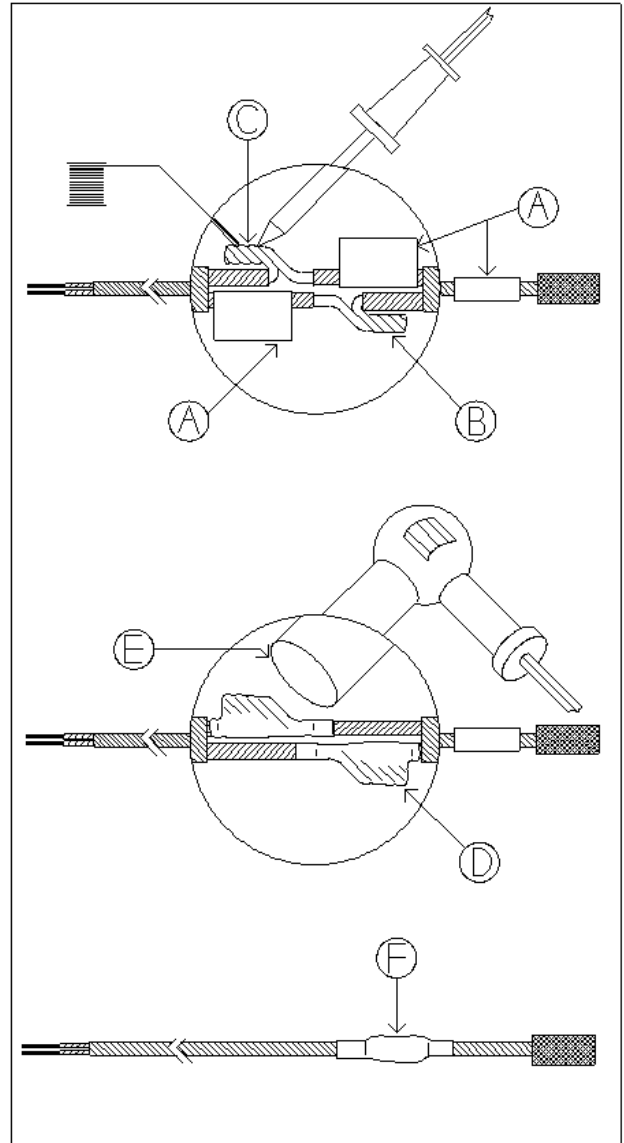

Alert siren installation



Connect alert to terminals 14, 15 and 16.
 14 - COMMON
 15 - NORMALLY OPEN
 16 - NORMALLY CLOSED

A - See the AEC-2 Electrical Ratings section for the alert relay ratings.

B & C - Use a backup battery and an appropriate charging system.

D - The siren ratings must not be greater than the alert relay ratings.

E - Alert disable switch.

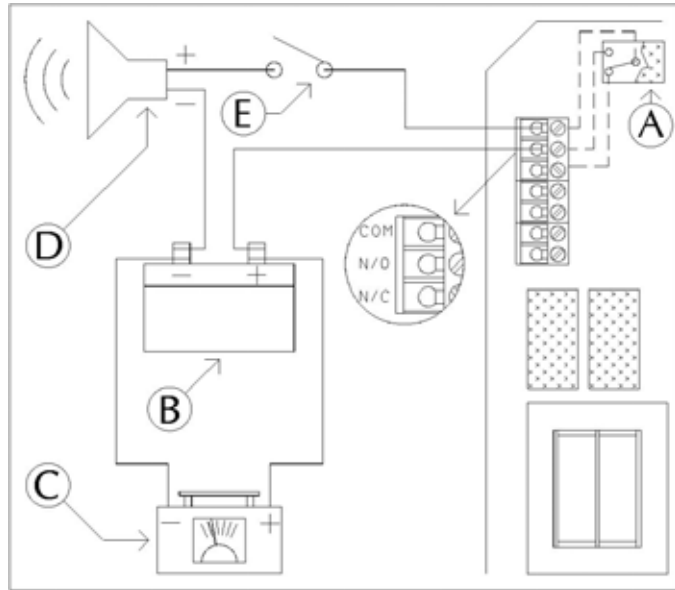

Alarm panel installation



Connect the alarm panel / auto-dialer to terminals 14, 15 or 16.
 14 - COMMON
 15 - NORMALLY OPEN
 16 - NORMALLY CLOSED

A - See the AEC-2 Electrical Ratings section for the alert relay ratings.

B - Consult the Alarm Panel / Auto-dialer owner's manual for proper installation guidelines

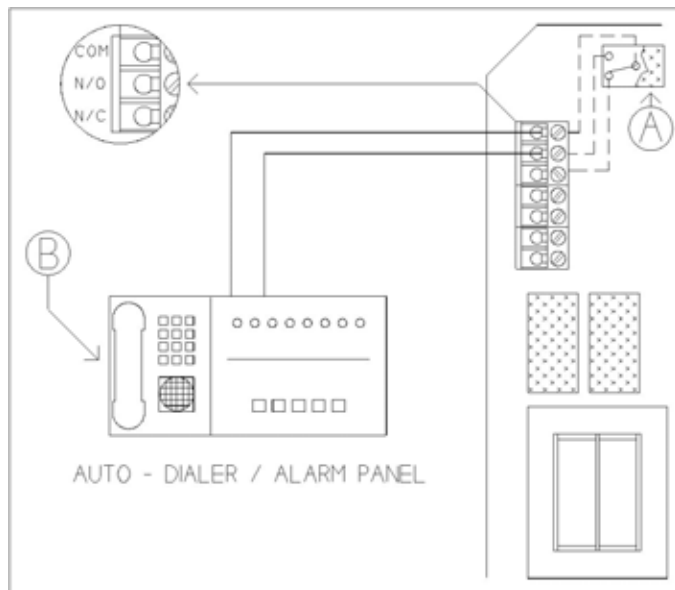

230 VAC heat/cool stages

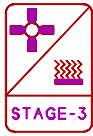

Connect Stage 2 to terminals 26 and 27.
Connect Stage 3 to terminals 24 and 25.

A - Relay Ratings: 6 FLA at 230 VAC, 360 Watts Tungsten

B - 230 VAC power contactor. A power contactor can be ordered from PHASON. Be sure the power contactor is rated for the particular load.

C - Load type: fan or heater.

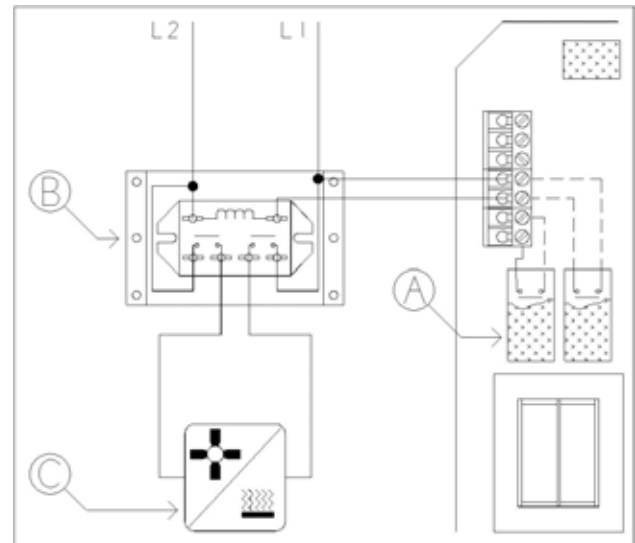

Install according to applicable local electrical codes.

115 VAC heat/cool stages

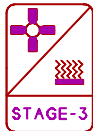

Connect Stage 2 to terminals 26 and 27.
Connect Stage 3 to terminals 24 and 25.

A - Relay Ratings: 6 FLA at 115 VAC, 360 Watts Tungsten

B - 115 VAC power contactor. A power contactor can be ordered from PHASON. Be sure the power contactor is rated for the particular load.

C - Load type: fan or heater.

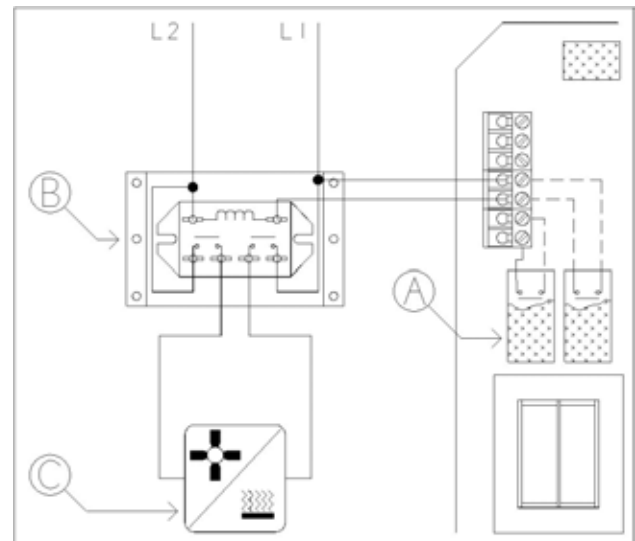

Install according to applicable local electrical codes

Heat/cool stage furnace

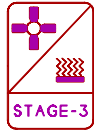

Connect Stage 3 to terminals 26 and 27.
 Connect Stage 4 to terminals 24 and 25.

A - Relay Ratings: 2.2 FLA, 230 VAC
 4.4 FLA, 115 VAC

B - This configuration shows the AEC-2 connected to the power mains for a gas fired furnace or brooder.

C - Use a suitable junction box for the wire connections.

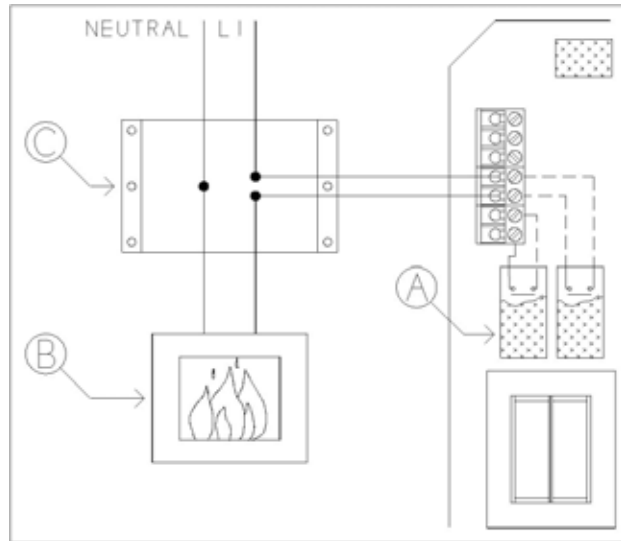

Heat/cool stage furnace

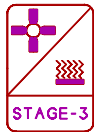

Connect Stage 2 to terminals 26 and 27.
 Connect Stage 3 to terminals 24 and 25.

A - Relay Ratings: 2.2 FLA, 230 VAC
 4.4 FLA, 115 VAC

B - In this configuration the AEC-2 is connected to the thermostat inputs of a gas fired furnace or brooder.



Gas furnaces using hot-surface ignition or glow plugs may draw a higher current than indicated and require a power contactor. Consult furnace agent for details

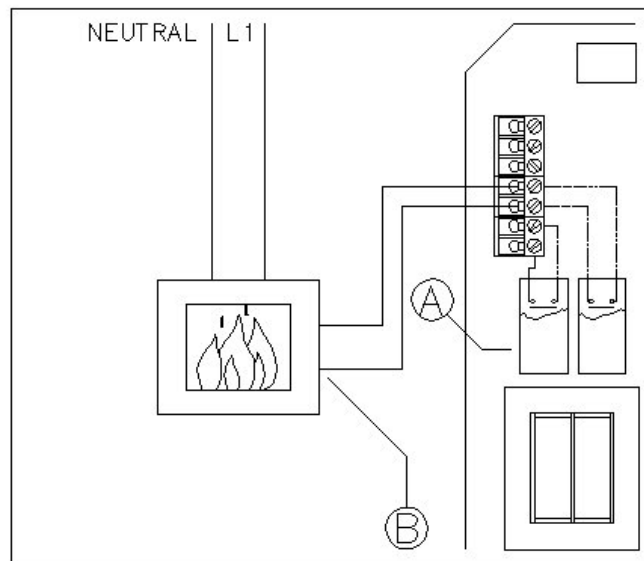

Heat/cool bypass switch

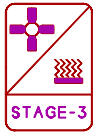

A - A bypass switch may be installed so the stage can be operated manually, turned off, or controlled automatically by the AEC-2. When the switch is in the right position the stage will be controlled automatically. When the switch is in the center position the stage will be off, and when the switch is in the left position (manual position) the stage will be fully on.

Connect a "SPDT center off" switch. This switch can be ordered from PHASON.

This switch is NOT a disconnect switch.

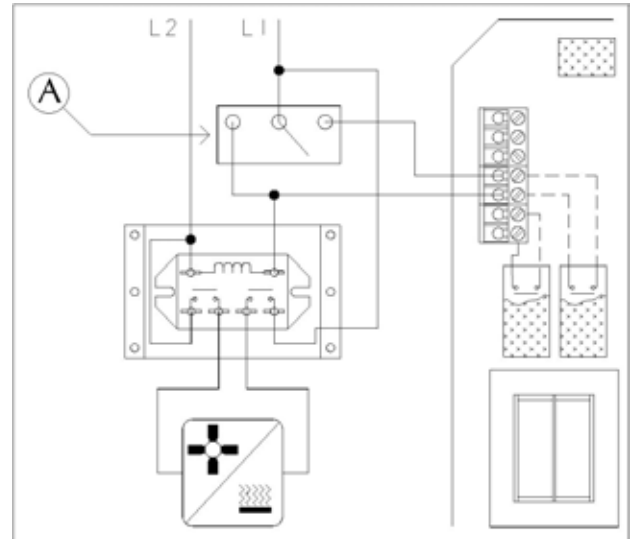

Variable stage bypass switch



A - A bypass switch may be installed so the fan can be operated manually, turned off, or controlled automatically by the AEC-2. When the switch is in the upper position the fan will be controlled automatically. When the switch is in the center position the fan will be off, and when the switch is in the lower position (manual position) the fan will be on full speed.

Connect a "SPDT center off" switch. This switch can be ordered from PHASON.

This switch is NOT a disconnect switch.

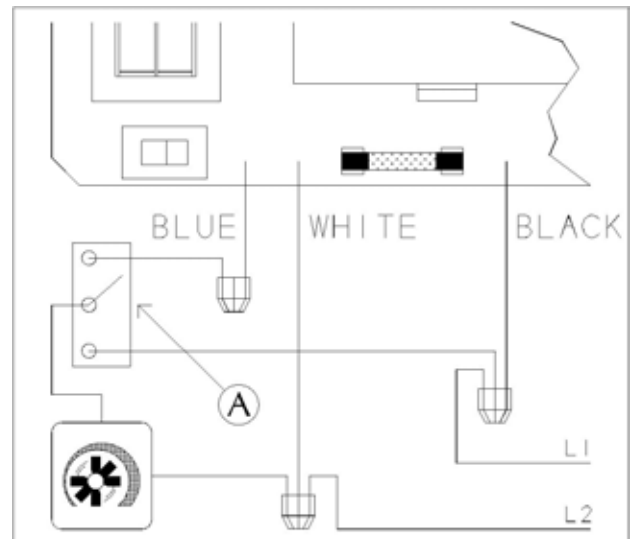

Appendix B - Test procedure

Built-in test procedure	B-2
Input test	B-2
Memory test	B-2
Display test	B-3
Variable stage test	B-3
Relay test	B-3
Reset test	B-4

Built-in test procedure

The AEC-2 has a built in test procedure. The test should be performed after the control has been installed and may be used at any time to check the operation of the control. The test procedure tests the circuitry in the control and each stage individually. Follow the instructions below to step through the test procedure.



If an alert system is connected, be aware that it is normal for the alert to be activated during most of the test procedure.

In order to start the test procedure, power to the AEC-2 must be off. Then, while holding the UP and DOWN buttons in, turn on the power. The AEC-2 will start up in the test mode.



Input test

1) Press the PROG button once. The AEC-2 will display a number. This number should be between 100.0 and 125.0.

Press the PROG button again and the AEC-2 will display the temperature. If the temperature displayed is not correct, check if the sensor is installed properly.



Memory test

2) Press the STORE button. The AEC-2 will display PASS if the factory programs are in memory. It will display FAIL if the programs in memory have been changed in any way from the factory settings. See Reloading the Factory Programs under the Getting To Know The AEC-2 section in this user's guide to reload the factory programs.



Display test

3) Press the PARM button to perform the display test. The AEC-2 will display 8888 and then will count from 0 to 9 on each digit. After the display test is done the AEC-2 will flash "t ds" which stands for test display.



Variable stage test

4) Press the UP button once. This will start the variable speed fan test. The display should be flashing tSP1 and °FF, ("tSP1" means test variable speed stage 1). Press the UP button again. Now the display should flash tSP1 and FuLL, and the Stage 1 fan should be running full speed. Press UP again and the fan should be running at approximately half speed, and the display should flash tSP1 and HALF. Press UP again and the fan will run at low speed. The display will flash tSP1 and Lo. NOTE: Some fans may not operate at this low speed. Pressing the UP button again will restart the Stage 1 fan test.



If at any time during this test the fans do not operate properly, refer to the troubleshooting guide in Appendix C.

Relay test

5) Press the DOWN button to start the relay test. The display will flash t rL and ALAr, ("t rL" stands for test relay), and the alert should be on. Press the DOWN button again and the display will flash t rL and St 2. Now Stage 2 should be on and the alert will be off. Press DOWN again and the display will flash t rL and St 3, and Stage 3 will turn on and Stage 2 will turn off. Press the DOWN button again and the display will flash t rL and ALL. Now Stages 2 and 3 will be on. Pressing DOWN again will restart the relay test cycle.

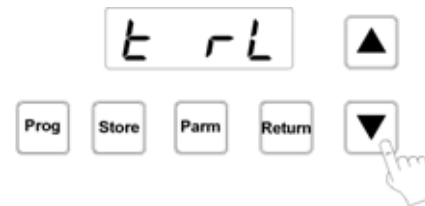

If any of the stages did not function properly when activated, refer to the troubleshooting guide in Appendix C.

Reset test

6) Press the RETURN button. This will return the AEC-2 to normal operation. The display will flash t SA for one second and then reset itself, ("t SA" stands for test sanity circuit). When the control is in normal operation the display will be flashing the room temperature and a power failure alert, (A PF). Press the RETURN button to clear the alert. Other alerts might be displayed if the AEC-2 has not yet been programmed, but this is a normal occurrence.



This completes the test procedure for the AEC-2. If at any point during this test the AEC-2 or attached equipment did not function properly, refer to the troubleshooting guide in Appendix C.

Appendix C - Troubleshooting guide

Troubleshooting C-2

Troubleshooting

Problem	Cause	Solution
No Power/Display	Circuit breaker at service panel is off or tripped	Reset the circuit breaker
	15 Amp, ABC-15 Fuse open	Replace fuse
	Wiring incorrect	Correct wiring
	115/230 VAC switch in the wrong position	Set the switch to the correct setting
Stage 1 Fan does not run	Wiring incorrect	Correct wiring
	15 Amp, ABC-15 Fuse open	Replace fuse(s)
	Minimum ventilation setting is too low (Parameter 2)	Increase minimum ventilation settings
	Stage 1 Minimum Idle setting is too low (Parameter 16)	Increase minimum idle setting
	Temperature Set setting above room temperature (Parameter 1)	Adjust Temperature Set to desired temperature
	Room temperature below range of Stage 1 Off-Set-Back (Parameter 4)	Adjust Off-Set-Back to cover required range
	Ventilation is turned off (Voff) (Parameter 12)	Change Ventilation to on
	Fan is faulty	Replace fan
Stage 1 fan runs full speed	Wiring incorrect	Correct wiring
	Minimum ventilation setting is too high (Parameter 2)	Decrease the minimum ventilation setting
	Stage 1 P-Band is set to 0 (Parameter 5)	Increase the Stage 1 P-Band
	Room temperature is above the Temperature Set (Parameter 1)	Adjust the Temperature Set to the desired temperature
Stage 1 fan runs erratically	P.F. Compensation is not set correctly	Adjust P.F. Compensation (Parameter 17)
Stages 2 or 3 Relay(s) not operating loads	Wiring incorrect	Correct wiring
	Turn On settings for the stages are incorrect (Parameters 6/7)	Adjust the Turn On settings
	The wrong Setup parameters are selected (Parameters 14/15)	Correct the Setup Parameter settings
	Ventilation is turned off (Voff) (Parameter 12)	Change Ventilation to on
	Note: This is only applicable to stages in cooling mode	
	Fan/Heater is faulty	Replace Fan/Heater
Alert relay is not operating the alarm system	Wiring incorrect	Correct wiring
Alert message on display	Alert condition is present or has occurred	See Alert section. Clear the alert condition by pressing RETURN.

Appendix D - Blank program tables

Blank parameter chart D-2

Blank setup parameter chart D-2

Blank parameter chart

When changes to the programs are made the changes should be marked in the tables below. This will provide a quick reference chart to refer to when reprogramming the AEC-2 in the future.

#	Parameters	Program names (A-H)							
		A	b	C	d	E	F	g	H
Main									
1	Temp Set (Start P-Band)								
2	Stage 1 Min Vent								
3	Cutback Speed								
Differential									
4	Stage 1 Off-Set-Back								
5	Stage 1 P-Band								
6	Stage 2 Turn On								
7	Stage 3 Turn On								
Alerts									
8	Low Temp Alert								
9	High Temp Alert								
General									
10	Low Power Alert								
11	Alert Display Latching								
12	Ventilation								

Blank setup parameter chart

#	Setup (hidden parameters)	Setting
13	Temperature Units	
14	Stage 2 Heat or Cool	
15	Stage 3 Heat or Cool	
16	Stage 1 Minimum Idle	
17	Stage 1 P.F. Compensation	
18	Hysteresis	

