

7176 STEP/DIR PLUS I/O DAUGHTERCARD

V1.22

Table of Contents

GENERAL	1
DESCRIPTION	1
HARDWARE CONFIGURATION	2
GENERAL	2
VIN POWER SOURCE	2
CABLE 5V POWER	2
SETUP/OPERATE MODE	2
ENCODER INPUT MODE	2
CONNECTORS	3
7176 CONNECTOR LOCATIONS AND DEFAULT JUMPER POSITIONS	3
HOST INTERFACE CONNECTOR	4
TB2 STEP AND DIR CONNECTOR	5
TB3 STEP/DIR, ENCODER AND RS-422 CONNECTOR	6
TB4 SPINDLE CONNECTOR	7
FIELD INPUT/OUTPUT CONNECTORS	8
TB6 PINOUT	8
TB5 PINOUT	9
FIELD POWER CONNECTOR	10
OPERATION	11
HOST INTERFACE	11
STEP/DIR INTERFACE	11
RS-422 INTERFACE	11
ENCODER INTERFACE	12
SPINDLE INTERFACE	12
SPINDLE ISOLATED OUTPUTS	12
STATUS LEDS	12

Table of Contents

OPERATION

FIELD I/O	13
FIELD AND VIN POWER SUPPLY	13
FIELD OUTPUT CHARACTERISTICS	13
WHY SOURCING OUTPUTS	13
SHORT CIRCUIT PROTECTION	13
OVERTEMPERATURE PROTECTION	13
MAXIMUM PER CHIP CURRENT	14
VOLTAGE CLAMPS	14
FIELD INPUT CHARACTERISTICS	14
WHY SINKING INPUTS	14
ANALOG INPUTS	14
FIELD VOLTAGE MONITORING	14
WATCHDOG AND FAULTS	15
FIELD I/O PARAMETERS	15
NON-VOLATILE FIELD I/O PARAMETERS	16
OPERATE MODE BAUD RATE	16
WATCHDOG TIMEOUT	16
RPD, WPD, AND UFLBP	17
SOFTWARE PROCESS DATA MODES	18

Table of Contents

REFERENCE INFORMATION	
SSLBP	19
GENERAL	19
REGISTER MAP	19
PROCESS INTERFACE REGISTERS	19
COMMAND REGISTER	20
COMMAND REGISTER WRITE IGNORE	20
DATA REGISTER	21
LOCAL READ OPERATIONS	21
LOCAL WRITE OPERATIONS	21
LOCAL PARAMETERS	22
NORMAL START	23
STOP ALL	24
STOP INDIVIDUAL CHANNELS	24
DOIT	24
PER CHANNEL INTERFACE DATA REGISTERS	25
PER CHANNEL CONTROL AND STATUS REGISTERS	25
REMOTE MODES	25
INTERFACE AND CS REGISTER CONTENTS AT START	25
CS REGISTER AFTER START	27
CS REGISTER AFTER DOIT	27
PROCESS DATA DISCOVERY	28
PROCESS TABLE OF CONTENTS	28
PROCESS DATA DESCRIPTOR	29
PROCESS DATA DESCRIPTOR FIELDS	29
RECORD_TYPE	29
DATA_LENGTH	29
DATA_TYPE	30
DATA_DIRECTION	30
PARAMETER_MIN	30
PARAMETER_MAX	30
UNIT_STRING	31
NAME_STRING	31
NUMERIC PROCESS DATA SCALING	31
MODE DESCRIPTOR	31
MODE TYPES	31
PROCESS ELEMENT PACKING AND UNPACKING	32
7176 SPECIFIC PROCESS DATA EXAMPLE	33
NORMAL MODE OPERATION	35
SETUP START	36
SETUP MODE OPERATION	36
REMOTE READ EXAMPLE	36
REMOTE WRITE EXAMPLE	37
DISCOVERY SEQUENCE	38

Table of Contents

REFERENCE INFORMATION	41
LBP	41
LBP DATA READ/WRITEWCOMMAND	41
EXAMPLE COMMANDS	42
LOCAL LBP COMMANDS	43
LOCAL LBP READ COMMANDS	43
LOCAL LBP WRITE COMMANDS	45
RPC COMMANDS	45
EXAMPLE RPC COMMAND LIST	47
SPECIAL RPCS	48
CRC	48
FRAMING	48
SSERIAL REMOTE RPCS	49
SPECIFICATIONS	50
DRAWINGS	52

GENERAL

DESCRIPTION

The 7176 is daughtercard/breakout board for use with MESA's 25 pin I/O FPGA cards like the 5125. The 7176 is designed for interfacing up to 5 Axis of step & dir step motor or servo motor drives and also provides a spindle encoder interface, isolated analog spindle speed control and 48 isolated I/O points for general purpose field I/O use.

All step and direction outputs are buffered 5V signals that can drive 24 mA. All outputs support differential mode to reduce susceptibility to noise. An isolated analog spindle voltage with direction and enable outputs is provided for spindle control as is a single spindle encoder channel with TTL or differential inputs.

48 points of isolated field I/O are provided for general control use including limit switch and control panel inputs, coolant enable and tool changer control outputs. Isolated I/O includes 32 sinking inputs and 16 sourcing outputs. Inputs can sense 5V to 32V signals and the outputs can switch 5V through 32V signals. Maximum output load is 300 mA. Outputs are short circuit protected. Field I/O is powered by an isolated 8-32V field power source.

One RS-422 interface is provided for I/O expansion via a serial I/O daughtercard. All field wiring is terminated in pluggable 3.5 mm screw terminal blocks.

HARDWARE CONFIGURATION

GENERAL

Hardware setup jumper positions assume that the 7176 card is oriented in an upright position, that is, with the host interface DB25 connector pointing towards the left.

VIN POWER SOURCE

The isolated field I/O on the 7176 runs from a switching power supply that can be powered by field power or a separate supply (VIN) with ground common with field power. Normally the 7176's VIN will be powered with field power. An on card jumper, W1 allows VIN to be connected to field power. If you wish to use a single power supply for the 7176's field outputs and field logic power, W1 should be placed in the left hand position. This connects field power to VIN. If you wish to use a separate supply for VIN, W1 should be placed in the right hand position.

CABLE 5V POWER

The 7176 can get its 5V encoder, step/dir and serial interface power from the host interface card if desired. W2 determines if the 7176 gets this 5V power from the host FPGA card. If W2 is in the left hand position, host cable power is used. If W2 is in the right hand position, 5V power must be supplied to the 7176 via TB3. This option must be set to match the cable power option of the host FPGA card. If the FPGA card supplies 5V, W2 must be in the left hand position. If the FPGA card does not supply 5V, W2 must be in the right hand position. **Never apply external 5V power to the 7176's TB3 connector when W2 is in the left hand position or you may damage the 7176, FPGA card, PC, or connecting cable.**

SETUP/OPERATE MODE

The 7176 can run in setup mode or operate mode. In setup mode, the serial interface baud rate is fixed at 115.2K baud. In the operate mode, the baud rate is set to 2.5M baud (default). Setup mode enables a normal PC to communicate with the 7176 for setup purposes. W3 controls the setup/operate mode selection. W3 **must** be in the "operate" mode for normal operation.

W3	MODE	BAUD RATE
LEFT	Operate mode	2.5M baud (default, can be changed)
RIGHT	Setup Mode	115.2K baud (fixed)

ENCODER INPUT MODE

The 7176's high speed encoder input can be programmed for differential or single ended mode operation. W4, W5 and W6 set the encoder input mode. When W4, W5, and W6 are in the right hand position, the encoder input mode is differential. When W4, W5, and W6 are in the left hand position, the encoder input mode is single ended or "TTL".

CONNECTORS

7176 CONNECTOR LOCATIONS AND DEFAULT JUMPER POSITIONS

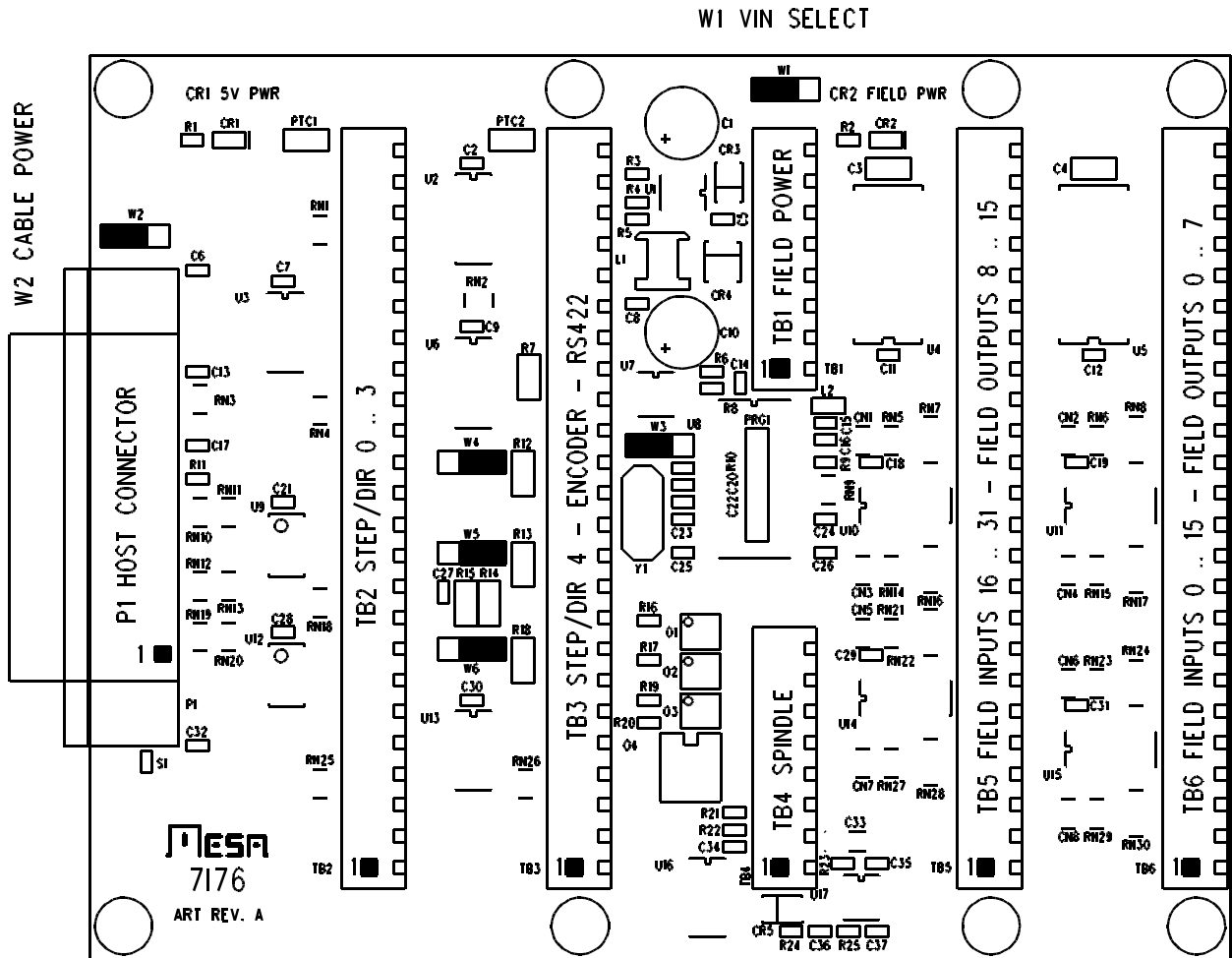

NOTE: TERMINAL BLOCK PIN 1'S ARE MARKED WITH SQUARE PAD

CONNECTORS

P1 HOST INTERFACE CONNECTOR

P1 is the DB25F connector on the 7I76 that connects to the FPGA card. Actual pin functions depend on FPGA configuration but signal directions must be observed.

DB25 PIN	GPIO	FUNCT	DIR	DB25 PIN	GPIO	FUNC	DIR
1	IO0	DIR0	OUT	14	IO1	STEP0	OUT
2	IO2	DIR1	OUT	15	IO3	STEP1	OUT
3	IO4	DIR2	OUT	16	IO5	STEP2	OUT
4	IO6	DIR3	OUT	17	IO7	STEP3	OUT
5	IO8	DIR4	OUT	18		GND	
6	IO9	STEP4	OUT	19		GND	
7	IO10	SS0TX	OUT	20		GND	
8	IO11	SS0RX	IN	21		GND	
9	IO12	SS1TX	OUT	22		GND or 5V	
10	IO13	SS1RX	IN	23		GND or 5V	
11	IO14	ENCI	IN	24		GND or 5V	
12	IO15	ENCB	IN	25		GND or 5V	
13	IO16	ENCA	IN				

Notes

1. If jumper W2 is in the left hand position, pins 22 through 25 are 5V, if W2 is in the right hand position, Pins 22 through 25 are GND.
2. GPIO pins are for first FPGA connector, next connector series begins at GPIO17
3. Signal directions are relative to FPGA card, that is, an 'OUT' signal is an output from the FPGA card that drives the 7I76. Conversely an 'IN' signal is a FPGA input that is driven by the 7I76.

CONNECTORS

TB2 STEP AND DIR CONNECTOR

TB2 is the 7176s main step and direction output connector. Both polarities of step and direction signals are provided. Each channel on the interface uses 6 pins. TB2 is a 3.5 MM pluggable terminal block with supplied removable screw terminal plugs.

TB2 CONNECTOR PINOUT

TB2 PIN	SIGNAL	TB2 PIN	SIGNAL
1	GND	13	GND
2	STEP0-	14	STEP2-
3	STEP0+	15	STEP2+
4	DIR0-	16	DIR2-
5	DIR0+	17	DIR2+
6	+5VP	18	+5VP
7	GND	19	GND
8	STEP1-	20	STEP3-
9	STEP1+	21	STEP3+
10	DIR1-	22	DIR3-
11	DIR1+	23	DIR3+
12	+5VP	24	+5VP

Note: 5VP pins are PTC short circuit protected 5V output pins for field wiring.

CONNECTORS

TB3 STEP/DIR, ENCODER AND RS-422 CONNECTOR

TB3 has a mix of signals including step/dir channel 4, an encoder interface, a RS-422 interface, and 5V power supply terminals TB3 is a 24 terminal 3.5 MM pluggable terminal block with supplied removable screw terminal plugs.

TB3 CONNECTOR PINOUT

TB3 PIN	SIGNAL	TB3 PIN	SIGNAL
1	GND	13	IDX+
2	STEP4-	14	IDX-
3	STEP4+	15	GND
4	DIR4-	16	RS-422 RX+
5	DIR4+	17	RS-422 RX-
6	+5VP	18	RS-422 TX+
7	ENCA+	19	RS-422 TX-
8	ENCA-	20	+5VP
9	GND	21	+5V 5V supply power
10	ENCB+	22	+5V 5V supply power
11	ENCB-	23	GND
12	+5VP	24	GND

Note: 5VP pins are PTC short circuit protected 5V output pins for field wiring.

CONNECTORS

TB4 SPINDLE CONNECTOR

TB4 is the spindle drive interface with isolated analog output and control signals for a spindle interface. TB4 is a 8 terminal 3.5 MM pluggable terminal block with supplied removable screw terminal plugs.

TB4 PINOUT

TB4 PIN	SIGNAL
1	SPINDLE-
2	SPINDLE OUT
3	SPINDLE+
4	NC
5	SPINDLE ENA-
6	SPINDLE ENA+
7	SPINDLE DIR-
8	SPINDLE DIR+

CONNECTORS

FIELD INPUT/OUTPUT CONNECTORS

Terminal blocks TB6 and TB5 are the 7176s field input and output terminals. Inputs 0 through 15 and outputs 0 through 7 are terminated at TB6. Inputs 16 through 31 and outputs 8 through 15 are terminated at TB5. TB6 and TB5 are 3.5 MM pluggable terminal block with supplied removable screw terminal plugs. Pin one is at the bottom edge of the 7176 card.

TB6 CONNECTOR PINOUT

TB6 PIN	I/O	TB6 PIN	I/O
1	INPUT0	13	INPUT12
2	INPUT1	14	INPUT13
3	INPUT2	15	INPUT14
4	INPUT3	16	INPUT15
5	INPUT4	17	OUTPUT0
6	INPUT5	18	OUTPUT1
7	INPUT6	19	OUTPUT2
8	INPUT7	20	OUTPUT3
9	INPUT8	21	OUTPUT4
10	INPUT9	22	OUTPUT5
11	INPUT10	23	OUTPUT6
12	INPUT11	24	OUTPUT7

CONNECTORS

FIELD INPUT/OUTPUT CONNECTORS

TB5 CONNECTOR PINOUT

TB5 PIN	OUTPUT	TB5 PIN	OUTPUT
1	INPUT16	13	INPUT28
2	INPUT17	14	INPUT29
3	INPUT18	15	INPUT30
4	INPUT19	16	INPUT31
5	INPUT20	17	OUTPUT8
6	INPUT21	18	OUTPUT9
7	INPUT22	19	OUTPUT10
8	INPUT23	20	OUTPUT11
9	INPUT24	21	OUTPUT12
10	INPUT25	22	OUTPUT13
11	INPUT26	23	OUTPUT14
12	INPUT27	24	OUTPUT15

CONNECTORS

FIELD POWER CONNECTOR

TB1 is the 7176s field power connector. TB1 pinout is as follows:

TB1 PIN	SIGNAL	FUNCTION
1	VFIELD	FIELD POWER 8-32V (Bottom pin)
2	VFIELD	FIELD POWER 8-32V
3	VFIELD	FIELD POWER 8-32V
4	VFIELD	FIELD POWER 8-32V
5	VIN	LOGIC POWER 8-32V
6	NC	
7	NC	
8	GROUND	VIN, VFIELD, COMMON (Top pin)

Note: When W1 is in the default left hand position, VIN is connected to VFIELD, so only VFIELD need be supplied to the 7176 to power its field IO.

OPERATION

HOST INTERFACE

The 7176 is intended to operate with a FPGA card with parallel port pinout like the Mesa 5I25 or 6I25. The FPGA card supports the step/dir, encoder, and smart serial interface used by the field I/O and spindle interface and expansion RS-422 port. The FPGA card can also supply 5V power to the 7176.

STEP/DIR INTERFACE

The 7176 provides five channels of step/dir interface with buffered 5V differential signal pairs. Each differential pair consists of two complementary 5V outputs. The differential signals allows reliable signal transmission in noisy environments and can directly interface with RS-422 line receivers. Step motor drives with single ended inputs connect to just one of the STEP and DIR signal outputs, that is either the STEP+/DIR+ or STEP-/DIR- signals, with the unused signals left unconnected at the 7176. The input common signal on drives with single ended inputs connects to the 7176s GND or 5VP pins depending on the drive type.

RS-422 INTERFACE

The 7176 has one RS-422 interface available on TB3. This interface is intended for I/O expansion with Mesa SSERIAL devices. The easiest way to make a cable for interfacing the 7176 to these devices is to take a standard CAT5 or CAT6 cable, cut it in half, and wire the individual wires to the 7176 screw terminals. The following chart gives the CAT5 to 7176 screw terminal connections (EIA/TIA 568B colors shown):

TB3 PIN	SIGNAL	DIRECTION	CAT5 PINS	CAT5 568B COLOR
15	GND	FROM 7176	4,5	BLUE, BLUE / WHITE
16	RX+	TO 7176	6	GREEN
17	RX-	TO 7176	3	GREEN / WHITE
18	TX+	FROM 7176	2	ORANGE
19	TX-	FROM 7176	1	ORANGE / WHITE
20	+5V	FROM 7176	7,8	BROWN / WHITE,BROWN

Note: The 6 pin terminal block requires the +5V (brown and brown/white) and ground (blue and blue/white) pairs to be terminated in single screw terminal positions.

OPERATION

ENCODER INTERFACE

The 7176 provide a one channel encoder interface with index. This is intended as a spindle encoder but can be used for other purposes. The encoder input can be programmed for differential or single ended encoders. The encoder interface also provides short circuit protected 5V power to the encoder. When used with single ended encoders, the ENCA+, ENCB+ and IDX+ signals are wired to the encoder and the ENCA-, ENCB-, and IDX- terminal left unconnected.

SPINDLE INTERFACE

The 7176 provides one analog output for spindle control. The analog output is a isolated potentiometer replacement type device. It functions like a potentiometer with SPINDLE + being one end of the potentiometer, SPINDLEOUT being the wiper and SPINDLE- being the other end. The voltage on SPINDLEOUT can be set to any voltage between SPINDLE- and SPINDLE+. Polarity and voltage range must always be observed for proper operation. The voltage supplied between SPINDLE+ and SPINDLE- must be between 5VDC an 15VDC with SPINDLE + always being more positive than SPINDLE-.

Because the analog output is isolated, bipolar output is possible, for example with SPINDLE+ connected to 5V and SPINDLE- connected to -5V, a +-5V analog output range is created. In this case the spindle output must be offset so that 50% of full scale is output when a 0V output is required. Note that if bipolar output is used, the output will be forced to SPINDLE- at startup or when SPINENA is false.

SPINDLE ISOLATED OUTPUTS

The 7176 provides 2 isolated outputs for use for spindle direction control, and spindle enable. These outputs are OPTO coupler Darlington transistors. They are all isolated from one another so can be used for pull up or pull-down individually. They will switch a maximum of 50 mA at 0 to 100 VDC. The SPINENA output is special as it uses the same signal that enables the analog output. When the analog output is enabled, the SPINENA OPTO output is on.

STATUS LEDS

The 7176 has two yellow status LEDs for power monitoring, CR1 and CR2. CR1 on the top left side of the 7176 monitors 5V power. CR2 on the top right side of the 7176 monitors field power. **Both LEDs must be illuminated for normal operation.**

OPERATION

FIELD I/O

The 7176 has a 32 input, 16 output isolated field I/O system to support a wide range of input and output devices. The isolated I/O is intended for low voltage DC control systems (commonly 24VDC). Inputs are sinking type. That is they sense positive input voltages relative to field ground. Output are sourcing type, that is they supply field power to field ground referred loads.

VIN AND FIELD POWER SUPPLY

The 7176 field I/O runs from field power supplies of 5 to 32 VDC. Field power supplies the power to the 7176 outputs and with the default settings, determines the 7176 input thresholds.

VIN power runs the field I/O processor and normally is connected to field power. VIN must be greater than 8V for proper operation. This means VIN must come from a separate source if 5V field voltage is used. Power consumption is approximately 600 mW or 25 mA at 24V. *VIN power must be present for the 7176 field I/O to be detected and operate.* Field voltages that are too high or too low will cause faults.

FIELD OUTPUT CHARACTERISTICS

The 7176 field outputs are high side or sourcing type MOSFET drivers, that is they source positive voltage to a ground referred load. For example with a standard 24V field power, +24V connects to the 7176s field power input (on TB1) and the outputs on TB5 and TB6 now source +24V power to loads. All 7176 loads will have one side returned to ground or the negative lead of the 24V supply. The 7176s outputs can drive loads of up to 350 mA.

WHY SOURCING OUTPUTS

Sourcing type outputs were chosen for the 7176 because sourcing type field wiring is less likely to cause inadvertent device actuation from the most likely type of field wiring problem which is a short to ground.

SHORT CIRCUIT PROTECTION

The 7176s outputs have short circuit protection and will turn off if short circuit current exceeds approximately 800 mA. The 7176 firmware will detect this condition, disable the affected output and indicate a fault.

OVERTEMPERATURE PROTECTION

The output driver chips detect over temperature conditions. If the 7176 detects a driver chip with a over temperature warning flag asserted, it will disable the affected chip and indicate a fault.

OPERATION

FIELD OUTPUT CHARACTERISTICS

MAXIMUM PER CHIP CURRENT

Because of thermal limitations there is a maximum per driver chip total current of 1.4 amps continuous. Each driver chip connects to 8 sequential outputs. If this limit is exceeded, the driver chip may go into thermal shutdown.

VOLTAGE CLAMPS

The output driver chips used on the 7176 have built in Zener diode clamps to clamp inductive turn-off (fly-back) spikes. This means that flyback diodes are not normally required on small (less than 60 mA) inductive loads. ***If high current inductive loads are switched or inductive loads are switched at high frequencies, they must have flyback diodes to limit power dissipation in the 7176's driver chips.***

FIELD INPUT CHARACTERISTICS

The 7176 field inputs have a nominal input resistance of 10K Ohms to field power ground. 7176 inputs sense positive input voltages above a preset threshold. For best general purpose use, default input threshold is 50% of the field power supply voltage with 10% hysteresis. That is with a 24V field voltage an input must be brought to 60% of 24V = 14.4V to be sensed as high and then brought to 40% of 24V = 9.6V to be sensed as low. These accurate thresholds and hysteresis allow high speed field signal detection while maintaining excellent noise immunity.

WHY SINKING INPUTS

7176 field inputs are of the sinking type. That is, external power must be applied to the input to register as activated. This mode was chosen so that accidental grounding of an input will not register as an activated input.

It is suggested that inputs like limit switches use normally closed switches with one switch leg connected to field power and the other to the 7176 input pin, so the normal machine state (not at limits) is to have the inputs activated. This way, a open switch wire or wire shorted to ground will cause a detectable machine fault.

ANALOG INPUTS

All field input pins are capable of reading the input voltage. These are not highly accurate or high resolution but can be useful for things like potentiometer inputs. Input resolution is 8 bits and input full scale value is 36.3V. Accuracy is +-5%. Software process data modes 1 and 2 allow reading the analog voltage on inputs 0 through 3, in addition to the 32 digital bit inputs.

FIELD VOLTAGE MONITORING

The 7176 monitors the field voltage and can send this information to the host in some modes. If separate VIN is supplied to the 7176, the 7176 can report loss of field voltage to the host.

OPERATION

FIELD I/O WATCHDOG AND FAULTS

The 7176 has a watchdog timer that will set all set a fault flag if host communication does not occur at a minimum rate. Default watchdog time is 50 mS which means if not accessed at a greater than 20 Hz rate, the watchdog will bite and disable the outputs.

When a fault flag is set, outputs can not longer be set and the host must first clear the fault before normal operation can continue. This is also the 7176s startup condition, meaning the host must first clear the fault before starting normal operation. This is normally handled by SSLBP.

FIELD I/O PARAMETERS

The 7176 has several user settable parameters, but normally only a very few need be changed in normal operation.

PARAMETER	TYPE	FUNCTION
NVBAUDRATE	UINT	Sets operate mode baudrate
NVUNITNUMBER	ULONG	Non-volatile unit number
UNITNUMBER	ULONG	Working unit number
NVWATCHDOGTIME	UINT	Non-volatile watchdog time in mS
WATCHDOGTIME	UINT	Working watchdog time in ms
OUTPUT	UINT	16 bits of output data
INPUT	ULONG	32 bits of input data
FAULT	UINT	7176 fault register
STATUS	UINT	7176 status register

OPERATION

NON-VOLATILE FIELD I/O PARAMETERS

All non volatile parameters start with the letters NV. Non-volatile parameters are stored permanently in the processors EEPROM and are copied to the volatile working parameters at power-up. Because of this, non-volatile parameters only take affect after a 7176 power cycle.

OPERATE MODE BAUD RATE

The operate mode baud rate default is 2.5 MBaud. This should not be changed unless needed for non-standard applications. Baud rates are selected by writing an index value to the NVBAUDRATE parameter. The index numbers for available baud rates are as follows:

INDEX	BAUD	INDEX	BAUD	INDEX	BAUD
0	9600B	1	19200B	2	38400B
3	57600B	4	115200B	5	230400B
6	460800B	7	921600B	8	1.25MB
9	2.5MB*	10	5MB	11	10MB

WATCHDOG TIMEOUT

The default watchdog period is 50 mS but can be set to different periods to suit the application. Watchdog timeout units are mS. A watchdog timeout value of 0 will disable the watchdog. The watch dog is a safety feature and should normally not be disabled nor set to long timeout periods unless the consequences of loss of control of outputs is not important. The non-volatile watchdog timeout is set via the NVWATCHDOGTIMEOUT parameter. The working watchdog timeout is set with the WATCHDOGTIME parameter.

OPERATION

RPD, WPD, AND UFLBP

The RPD, WPD, and UFLBP are command line utilities allow reading and writing volatile and non-volatile 7176 parameters, and updating the firmware on the 7176 To use these utilities on most operating systems, the 7176 must be in the setup mode or the operate mode baud rate must be 115200 KBaud or less

RPD, WPD, and UFLBP need environment variables preset before they will work. For Windows and 115200 baud, the following environment variables should be set:

```
SET BAUDRATE=115200
```

```
SET BAUDRATEMUL=1
```

```
SET PROTOCOL=LBP
```

```
SET INTERFACE=OSDEVICE
```

Example setting NVWATCHDOGTIMEOUT to 100 ms:

```
WPD NVWATCHDOGTIME 100
```

Note this is permanent change in the 7176s watchdog timeout and like all non-volatile parameters, will only be applied after the 7176 has been power cycled

Example reading 7176 faults in Hexadecimal:

```
RPD FAULT H
```

Example of temporarily disabling watchdog and the setting every other output on:

```
WPD WATCHDOGTIME 0
```

```
WPD OUTPUT AAAAAAAAAAAAAA H
```

Example of updating 7176 firmware with UFLBP

```
UFLBP 7176.BIN
```

Note the 7176 MUST be in setup mode for UFLBP to work properly.

OPERATION

SOFTWARE PROCESS DATA MODES

The 7176 has three software selectable process data modes. These different modes select different sets of 7176 data to be transferred between the host and the 7176 during real time process data exchanges. For high speed applications, choosing the correct mode can reduce the data transfer sizes, resulting in higher maximum update rates.

- MODE 0 I/O only mode (32 bits of input data, 16 bit of output data)
- MODE 1 I/O plus analog input mode (32 bits of input data, 16 bits of output data, 4 analog input channels)
- MODE 2 I/O plus analog input and field voltage and MPG mode (32 bits of input data, 16 bits of output data, 4 analog input channels, field voltage analog in, and 2 MPG encoders on inputs 16..19). Default encoder count mode is 1X to match normal 100 PPR MPGs. Encoder input threshold is fixed at 2.5V for compatibility with 5V encoder outputs.

REFERENCE INFORMATION

Note that the following interface details presented here are not normally needed for users, as all register level interface details are handed by the driver code. This information is presented here for use by interface and driver developers.

SSLBP

GENERAL

SSLBP is a firmware option to HostMot2s SSERIAL serial interface that allows simple communication to LBP based peripherals like the 7176. SSERIAL is a part of the HostMot2 motion interface firmware for MESA's Anything-I/O FPGA cards.

REGISTER MAP

SSLBP has two global processor interface registers and four per channel remote device interface registers. For more details on mapping of these registers in HostMot2 memory space, see the REGMAP file that is included with the HostMot2 source distribution.

PROCESSOR INTERFACE REGISTERS

There are two processor interface registers, the COMMAND register and the DATA register. These registers allow low level communication to SSLBP's interface processor for issuing global commands, discovery, and debug operations.

REFERENCE INFORMATION

SSLBP

COMMAND REGISTER

The commands register is a 16 bit register (right justified in the 32 bit interface) with the following format:

15	14	13	12	11	10	9	8	7	6	5	4	3	2	1	0
W	M	R	D	S	T	T	T	N	N	N	N	N	N	N	N

W = BIT 15 Write bit, set high for control data write commands

M = BIT 14 ROM enable/ reset bit, set high to reset processor / download ROM

R = BIT 13 Request bit, set high for read or write command

D = BIT 12 Dolt bit, set high for Dolt commands

S = BIT 11 Start/Stop bit, actual operation depends on T:

ST = 1,0,0,0 Stop LBP interface = 0x08NN

ST = 1,0,0,1 Start LBP interface in normal mode = 0x09NN
 ST = 1,1,1,1 Start LBP interface in setup mode = 0x0FNN

N bits determine which channels start or do data transfer with remote device. A set bit indicates that the corresponding channel will start or do a data transfer.

A command is started when written to the command register. Command completion is signaled by the command register being cleared (to 0x0000) by the internal SSLBP firmware. If the command register is read before the command is complete, it will reflect the previously written command. *The command register should not be written when non-zero or unpredictable behavior may result.* There are two exceptions to this rule:

1. A STOP ALL command can always be written to reset the SSLBP interface.
2. Command writes with the ignore bit set can always be written (see below)

COMMAND REGISTER WRITE IGNORE

The command register has a feature that any command written with the MSB (bit 31) set will be ignored. This is for compatibility with DMA driven interfaces or any interfaces that use a fixed address list for low level hardware access so cannot skip writes.

REFERENCE INFORMATION

SSLBP

DATA REGISTER

SSLBP has a global 8 bit data register for debug and custom setup purposes. This register allows access to internal SSLBP parameters. The data register is right justified in the 32 bit Hostmot2 register.

LOCAL READ OPERATIONS

The sequence used for reading a local SSLBP variable is as follows:

1. The parameter address ORed with the Request bit (bit 13) is written to the command register.
2. The host polls the command register until it reads as zero.
3. The host reads the parameter byte from the data register

LOCAL WRITE OPERATIONS

The sequence used for writing a local SSLBP variable is as follows:

1. The host polls the command register until it reads as zero.
2. The host writes the data byte to the data register
3. The host writes the command register with the the parameter address Ored with both the Request bit (bit 13) and the Write bit (bit 15)

REFERENCE INFORMATION

SSLBP

LOCAL PARAMETERS

There are a number of local SSLBP read only parameters that are useful for interface software and drivers to access using the local read operations:

LOCAL PARAMETER	ADDRESS	DESCRIPTION
INTERFACE_TYPE	0x0000	0x12 for SSLBP
INTERFACE_WIDTH	0x0001	Data port width (8)
MAJORREV	0x0002	Major SSLBP firmware revision
MINORREV	0x0003	Minor SSLBP firmware revision
GP_INPUTS	0x0004	Number of GP input bits (0 for SSLBP)
GP_OUTPUTS	0x0005	Number of GP output bits (0 for SSLBP)
PROCESSOR_TYPE	0x0006	0xD8 for Dumb8
CHANNELS	0x0007	1 to 8 depending on configuration

REFERENCE INFORMATION

SSLBP

NORMAL START

When the FPGA is first configured or after a STOP command, all local communication, error and status parameters are initialized and all LBP communication channels are idle. A normal START command begins to establish communications with all remote LBP devices. A normal start command is issued by writing a Start bit with type bits of 0,0,1 with a bit mask of the desired channels to start in the low byte, This is 0x9NN hex where NN is the bitmask of channels to start. This command is written to the command register to start the selected channels.

Once a start command has been issued, all channels that are selected in the bit mask will be probed to determine if a LBP device exists. If a device exists on a channel, the SSLBP firmware will acquire the device name, and device unit number, and pointers to process data information from the remote device..

A normal start command also does a standard set of remote device setup operations when it detects a remote device. This setup includes clearing any faults, setting remote operational mode, and setting the outputs off. If no errors have occurred and all faults are clearable, the SSLBP firmware enters a "chatter" loop where it repeatedly sends output data of all 0's. This keeps the remote devices watchdog fed while waiting for the first DOIT command.

When the command completes (the command register is clear), the data register can be read to determine if all selected channels have started. A 1 bit in any position in the data register indicates that the corresponding channel has failed to start. If a channel has failed to start, more information about the failure can be determined by reading the CS register of the failed channel.

Once a DOIT command has been executed, the firmware no longer "chatters" and it becomes the responsibility of the host interface to continue sending DOIT commands at a rate sufficient to feed the remote devices watchdog (faster than 20 Hz with the default 50 mS watchdog timeout period). If this is not done, the remote device's watchdog will bite, disabling its outputs and setting the fault flag. This will require a channel stop followed by a channel start to resume normal operations.

REFERENCE INFORMATION

SSLBP

STOP ALL

A STOPALL command is issued to stop all channel communication. *STOPALL resets all channel variables and should always be issued by a driver when initializing the SSLBP interface.* A STOPALL followed by a START command can be used after a fault condition to re-establish communication with the remote LBP devices. Device discovery is only done once when START command is issued to a STOPed SSLBP. This means that if cabling, devices, or device hardware modes are are changed, a STOPALL command followed by a START command must be issued by the host to detect the changes. A STOPALL command is 0x0800.

STOP INDIVIDUAL CHANNELS

In addition to stopping all channels, a individual stop command can be issued. A individual stop command include a bitmask of the channels to stop in the least significant 8 bits of the command (the N bits), that is a stop channel 1 command would be 0x802. The intended use of individual stop is per channel error recovery. It should not be used for normal interface startup as it does not reset channel variables, that is a 0x8FF command (stop all individual channels) is not equivalent to a 0X800 (STOPALL) command.

DOIT

In normal operation SSLBP is designed to send host data from the interface registers to the remote device and request data from the remote device for presentation in the interface registers to the host. This SSLBP function is designed for high speed real time operation. Synchronization with the host is accomplished with the DOIT command.

When the host writes a DOIT command,, all outgoing process data from the host is sent to the remote devices and incoming process data is requested. Completion of the DOIT command is signaled by SSLBP clearing the COMMAND register. A DOIT command is completed when al requested channel transfers have completed or timed out. After the completion of a successful DOIT command, the incoming process data from the remote can be read.

A DOIT command contains the DOIT bit and an 8 bit mask in the 8 LSBs that selects the channels that will be requested to transfer data. *A DOIT should not be requested on an inactive channel, that is a channel that did not start.* After DOIT command completion the data register will contain a bit mask of channel status data. If any bit is set in the data register, it indicates a problem with the transfer (all zeros indicates no faults or errors).

The data register contents returned after a DOIT command can be used to minimize host access cycles by avoiding the need to read the per channel status registers. If detailed fault information is desired, the CS register can be read on any channel that shows a failed transfer.

REFERENCE INFORMATION

SSLBP

PER CHANNEL INTERFACE DATA REGISTERS

SSLBP supports three 32 bit interface data registers per channel. These are called interface register 0, interface register 1, and interface register 2. These are read/write registers with independent incoming and outgoing data. These registers are used for both setup/discovery data when starting a data link and process data once the link is running. When a start command is issued and has successfully completed, per channel setup data will be available in the interface registers.

PER CHANNEL CONTROL AND STATUS REGISTERS

SSLBP has a 32 bit control and status register for each channel. Like the interface data registers, these registers are used both for data link startup information and for status when the link is in operation.

REMOTE MODES

Some remote devices have software selectable modes that determine the specific data transferred for each DOIT command. These modes are selected by writing the mode number to the most significant byte of the remote channels CSR before a START or SETUP START command is issued. A default value of 0x00000000 should be written to all CSRs if MODE is not used.

REMOTE MODE IS WRITTEN TO CSR MS BYTE BEFORE START

CS REG	MODE	0	0	0.
--------	------	---	---	----

INTERFACE AND CS REGISTER DATA AT START

After a successful start command (either setup start or normal start), Interface register 0 reports the remote device's unit number. This is the number printed on the card label. Interface register 1 reports the remote device's 4 letter name (LSB first). Interface register 2 reports the remote devices global table of contents pointer (GTOCP) and process table of contents pointer (PTOCP) for the currently selected remote device mode. The GTOCP and PTOCP will be 0x0000 for devices that do not support process data discovery. *Note that the setup data will be overwritten with process data once the first DOIT command is issued.*

READ DATA FROM PER CHANNEL INTERFACE REGISTERS AFTER START

CS REG	X	COM_STATE	STATUS	LOCAL FLT.
INTERFACE 0	UNIT# BYTE 3	UNIT# BYTE 2	UNIT# BYTE 1	UNIT# BYTE 0
INTERFACE 1	NAME BYTE 3	NAME BYTE 2	NAME BYTE 1	NAME BYTE 0
INTERFACE 2	GTOCP BYTE1	GTOCP BYTE 0	PTOCP BYTE1	PTOCP BYTE 0

REFERENCE INFORMATION

SSLBP

CS REGISTER AFTER START

The CS register is used for local SSLBP, and remote LBP device status and control information. Read access returns status information in both normal and setup mode. In normal mode, writes to the CS register are not used. After a normal start or setup start the CS register has the following format:

Byte3 = X undefined for SSLBP versions < 29, remote fault for versions >28 (See CS REGISTER AFTER DOIT section)

Byte2 = COM_STATE Communication state code (debug only)

Byte1 = Communication status code (0x00 for OK)

Bit 7 = CommunicationNotReady

Bit 6 = NoRemotelD

Bit 5 = CommunicationError

Bit 0 = RemoteFault

Byte0 = Local Communication faults (sticky, cleared only by STOP)

Bit 7 = TooManyerrors

Bit 6 = RemoteFault

Bit 5 = SerialBreakError

Bit 4 = ExtraCharacterError

Bit 3 = TimeoutError

Bit 2 = OverrunError

Bit 1 = InvalidCookieError

Bit 0 = CRCError

REFERENCE INFORMATION

SSLBP

CS REGISTER AFTER DOIT

After a successful DOIT command, or normal start with SSLBP versions >28 bytes 0 through 2 of CS register are the same as after a start command but in addition, the previously invalid byte 3 of the CS register contains remote fault information:

Byte3 = REMOTE_FAULTS

Bit 7 = LBPCOMFault

Bit 6 = IllegalMode Fault

Bit 5 = LowVoltageFault

Bit 4 = HighVoltageFault

Bit 3 = OverCurrentFault

Bit 2 = OverTempFault

Bit 1 = NoEnableFault

Bit 0 = WatchdogFault

REFERENCE INFORMATION

SSLBP

PROCESS DATA DISCOVERY

The SSLBP interface provides information to allow the host to determine the name, number, units, sizes, types, directions, and scaling of process data elements. This information is read from the remote device via a setup mode start followed by a series of remote read operations.

Note to the bewildered: process data discovery and its complications are not needed to access the 7176 via SSLBP. In fact the 7176's data can be accessed via SSLBP with no more than a few register reads and writes. The sole purpose of process data discovery is to allow the driver to present nicely named and formatted data to the host without the driver having any built in knowledge of the remote device.

PROCESS TABLE OF CONTENTS

After a normal start or setup start command, the PTOCP word in the low word of interface register 2 is a pointer to the current process table of contents (PTOC) in the remote device.

If remote devices that do not support process device discovery are present, their PTOCP will be 0, and process data organization must be inferred from the remote device name.

Remote reads from this location will return the first entry in the PTOC. All PTOC entries are pointers with a size of 2 bytes. The end of the PTOC is marked with a 0 sentinel. Each PTOC entry points to a process data descriptor. Here is an example of a 5 entry PTOC (PDD is Process Data Descriptor)

ENTRY	ADDRESS	CONTENTS
0	PTOCP	POINTER TO PDD 0
1	PTOCP+2	POINTER TO PDD 1
2	PTOCP+4	POINTER TO PDD 2
3	PTOCP+6	POINTER TO PDD 3
4	PTOCP+8	POINTER TO PDD 4
5	PTOCP+10	0x0000 (END OF TABLE)

REFERENCE INFORMATION

SSLBP

PROCESS DATA DESCRIPTOR

Each PTOC entry points to a process data descriptor or a mode descriptor. Each process data descriptor is a record with fields for data size, data type, data direction, minimum and maximum values, the address of the process data and the unit name and process data name. Each process data element has a corresponding process data descriptor record. In addition there are mode descriptor records that indicate the current hardware and software modes of the remote device. The process data descriptor record structure is as follows:

FIELD NAME	FIELD LENGTH	DESCRIPTION
RECORD_TYPE	8 BITS	RECORD TYPE = 0xA0
DATA_SIZE	8 BITS	DATA SIZE IN BITS
DATA_TYPE	8 BITS	DATA ELEMENT TYPE
DATA_DIRECTION	8 BITS	DATA DIRECTION
PARAM_MIN	32 BITS	IEEE-754 FP PARM MIN
PARAM_MAX	32 BITS	IEEE-754 FP PARM MAX
PARAM_ADD	16 BITS	ADDRESS OF PARM
UNIT_STRING	VARIABLE	NULL TERM. STRING
NAME_STRING	VARIABLE	NULL TERM. STRING

PROCESS DATA DESCRIPTOR FIELDS

RECORD_TYPE

The RECORD_TYPE field is a single byte at the beginning of the process data descriptor for record typing and sanity checking. It is 0xA0 for process data records.

DATA_LENGTH

The DATA_LENGTH field is a single byte field that specifies the length of the process data element in bits. Minimum is 1 bit, maximum is 255 bits, however current SSLBP implementations are limited by the number of interface registers to a maximum of 96 bits.

REFERENCE INFORMATION

SSLBP

DATA_TYPE

The DATA_TYPE field is a single byte field that specifies the data type of the process data element. Data types are as follows:

NUMBER	DATA_TYPE	NOTE
0x00	PAD	To pad for byte alignment
0x01	BITS	Packed bits, LSB is BIT 0
0x02	UNSIGNED	Numeric unsigned
0x03	SIGNED	Numeric twos complement LSB first
0x04	NONVOL_UNSIGNED	Numeric unsigned
0x05	NONVOL_SIGNED	Numeric twos complement LSB first
0x06	STREAM	Continuous data stream
0x07	BOOLEAN	Any length non-zero = true

DATA_DIRECTION

The DATA_DIRECTION field is a single byte field that specifies the data direction. Valid Data direction bytes are as follows:

0x00	INPUT	(Read from remote)
0x40	BI_DIRECTIONAL	(Read from and written to remote)
0x80	OUTPUT	(Written to remote)

PARAMETER_MIN

The PARAMETER_MIN field is a 32 bit IEEE-754 floating point number that specifies the minimum value of the process data element. This is to allow the driver to present data in engineering units. Not valid for non-numeric data types

PARAMETER_MAX

The PARAMETER_MAX field is a 32 bit IEEE-754 floating point number that specifies the maximum value of the process data element. This is to allow the driver to present data in engineering units. Not valid for non-numeric data types.

REFERENCE INFORMATION

SSLBP

UNIT_STRING

The UNIT_STRING is a variable length null terminated string that specifies the units of the process data element

NAME_STRING

The NAME_STRING is a variable length null terminated string that begins immediately after the UNIT_STRING. It specifies the name of the process data element.

NUMERIC PROCESS DATA SCALING

Currently all numeric process data is simple unsigned or signed (twos complement) binary data. The process data element PARAM_MIN and PARAM_MAX values in conjunction with the DATA_SIZE can be used to scale this numeric data.

For unsigned data, PARAM_MIN corresponds to a value of 0 and PARAM_MAX corresponds to a value of $(2^{DATA_SIZE}) - 1$. Meaning scaled unsigned data is $RAW_DATA * (PARAM_MAX - PARAM_MIN) / ((2^{DATA_SIZE}) - 1) + PARAM_MIN$.

For signed data. PARAM_MIN corresponds the value $-(2^{DATA_SIZE-1}) - 1$ and PARAM_MAX corresponds the value $(2^{DATA_SIZE-1}) - 1$, meaning scaled signed data is $RAW_DATA * (PARAM_MAX - PARAM_MIN) / ((2^{DATA_SIZE-1}) - 1) + PARAM_MIN$.

MODE DESCRIPTOR

In addition to the process data descriptors, the PTOC will have pointers to two mode descriptors. These are the currently selected hardware and software modes of the remote device.

FIELD NAME	FIELD LENGTH	DESCRIPTION
RECORD_TYPE	8 BITS	RECORD TYPE = 0xB0
MODE INDEX	8 BITS	WHICH MODE
MODE TYPE	8 BITS	MODE TYPE
UNUSED	8 BITS	UNUSED
MODE_NAME_STRING	VARIABLE	NULL TERM. STRING

MODE TYPES

Currently there are only two mode types, HWMODE = 0x00 and SWMODE = 0x01 these correspond to hardware (EEPROM or Jumper setting)and software (dynamically changeable operational modes)

REFERENCE INFORMATION

SSLBP

PROCESS DATA ELEMENT PACKING AND UNPACKING

Ultimately all process data is transferred to and from the host via the interface 0,1,2 registers.

The packing of outgoing process data elements into these interface registers and unpacking of incoming process data elements from these interface registers is done in the order of process data descriptors listed in the PTOC. Process data elements in PTOC order and process descriptor DATA_SIZE are packed into or unpacked from the interface registers from LSB to MSB and from interface register 0 through interface register 2.

Read data and bidirectional data is unpacked from the interface registers read by the host. Write data and bidirectional data is packed into the interface registers written by the host.

Before a DOIT command is written to start a data transfer cycle with the remote device, the host must write its packed outgoing process data (OPD in table below) to the interface registers. (The CS register not currently used for outgoing data/control so is not written)

HOST WRITES OUTGOING INTERFACE REGISTERS BEFORE DOIT

CS REG	MODE	X	X	X
INTERFACE 0	OPD BYTE 3	OPD BYTE 2	OPD BYTE 1	OPD BYTE 0
INTERFACE 1	OPD BYTE 7	OPD BYTE 6	OPD BYTE 5	OPD BYTE 4
INTERFACE 2	OPD BYTE 11	OPD BYTE 10	OPD BYTE 9	OPD BYTE 8

REFERENCE INFORMATION

SSLBP

PROCESS DATA ELEMENT PACKING AND UNPACKING

After the DOIT command has completed, the incoming process data (IPD in table below) can be read along with the local and remote faults.

HOST READS INCOMING INTERFACE REGISTERS AFTER DOIT

CS REG	REMOTE. FLT	COM_STATE	STATUS	LOCAL FLT.
INTERFACE 0	IPD BYTE 3	IPD BYTE 2	IPD BYTE 1	IPD BYTE 0
INTERFACE 1	IPD BYTE 7	IPD BYTE 6	IPD BYTE 5	IPD BYTE 4
INTERFACE 2	IPD BYTE 11	IPD BYTE 10	IPD BYTE 9	IPD BYTE 8

7176 SPECIFIC PROCESS DATA EXAMPLE

Process data is remote device dependent and also dependent on remote device mode. The 7176 supports 3 software modes.

REFERENCE INFORMATION

SSLBP

7176 SPECIFIC PROCESS DATA EXAMPLE

In the default input/output mode the process data appears in the interface registers in the order shown:

7176 OUTGOING PROCESS DATA FOR MODE (1)

CS REG	X	X	X	X
INTERFACE 0	SPINOUT 15..8	SPINOUT 7..0	TB5 OUTS 15..8	TB6 OUTS 7..0
INTERFACE 1	X	X	SPINDIR	SPINENA
INTERFACE 2	X	X	X	X

7176 INCOMING PROCESS DATA FOR MODE (1)

CS REG	REMOTE. FLT	COM_STATE	STATUS	LOCAL FLT.
INTERFACE 0	TB5 INS 31..24	TB5 INS 23..16	TB6 INS 15..8	TB6 INS 7..0
INTERFACE 1	ANALOG3	ANALOG2	ANALOG1	ANALOG0
INTERFACE 2	X	X	X	X

Note that this information is just for user convenience as the process data organization in the interface registers can be determined by process data discovery.

REFERENCE INFORMATION

SSLBP

NORMAL MODE OPERATION

In normal mode the sequence of operations for a cyclic access with write before read is as follows:

Note steps 1 through 5 are setup operations and are only done once per session

1. Issue STOP ALL command (0x800), wait for COMMAND register clear to verify stop command completion.
2. Issue normal START command (0x9NN) with bitmask (NN) of channels to start.
3. Wait for COMMAND register clear to verify start command completion. (may be many mS)
4. Read data register to verify that all selected channels started (a 1 in any channel position bit means a fault in the channel that the bit represents)
5. Read device unit number (This can only be read before DOIT has been asserted)
6. Check command register, if not clear, cycle time is too short.

(Note the command register should never be written to when not clear except to issue a stop command or when written with the command ignore bit set)
7. Check data register, any 1 bits indicate previous DOIT command failed for in the corresponding channels
8. Read per channel Interface register 0 and interface register 1 for input process data
9. Write per channel output process data (for 7176) to interface 0 register and interface 1 register
10. Write DOIT command = 0x10NN where NN is the bit mask of channels to initiate transfers.
11. Wait for next cycle, at next cycle time, loop back to state 6

This sequence can be modified if a read-modify-write sequence is required, this requires polling the command register for send/receive completion. This will take a maximum of 100 uSec from the DOIT command to command register clear and valid input data.

REFERENCE INFORMATION

SETUP START

When the FPGA is first configured or after a stop all command, all LBP communication channels are idle. A SETUP START command first initializes and all local communication, error and status parameters and begins to establish communications with all remote LBP devices. Unlike the NORMAL START command, SETUP START does no device specific setup but instead creates a pass-through access mode that allows the host to read or write any remote LBP device parameter. This allows simple utilities to setup 7176 volatile and non-volatile parameters, and allows the host to do process data discovery to determine the input and output process data information from the remote device.

SETUP MODE OPERATION

In setup mode the SSLBP interface is used as a passthrough device to allow reading and writing parameters to the remote LBP device.

REMOTE READ EXAMPLE:

For a remote word read, the sequence of operations is as follows:

1. Issue a STOPALL command (0x800), wait for COMMAND register clear to verify stop command completion.
2. Issue a setup START command (0xFNN) with bitmask (NN) of channels to start
3. Wait for COMMAND register clear to verify start command completion. (may be many mS)
4. Read data register to verify that all selected channels started (a 1 bit means a fault in the channel that the bit represents)
5. Write LBP word read command (0x45) in the MSByte ORed with the parameter address to the selected channels CS register. (0x4500PPPP)
6. Issue a DOIT Command
7. Wait for the command register to be clear
8. Check that the data register is clear, any set bits indicate an error
9. Read the returned data in the LS word of the selected channels Interface0 register
10. Repeat from step 5 for any additional remote data reads

Remote read byte, word, long and double are basically equivalent, the only difference being the LBP command (0x44,0x45,0x46,0x47 respectively) and the size of the data read from the interface register(s)

REFERENCE INFORMATION

SSLBP

REMOTE WRITE EXAMPLE:

For a remote word write, the sequence of operations is as follows:

1. Issue a STOPALL (0x800) command, wait for COMMAND register clear to verify stop command completion.
2. Issue a setup START command (0xFNN) with bitmask (NN) of channels to start
3. Wait for COMMAND register clear to verify start command completion. (may be many mS)
4. Read data register to verify that all selected channels started (a 1 bit means a fault in the channel that the bit represents)
5. Write the new parameter data to the selected channels Interface0 register (right justified)
6. Write LBP word write command (0x65) in the MSByte ORed with the parameter address to the selected channels CS register. (0x6500PPPP)
7. Issue a DOIT Command
8. Wait for the command register to be clear
9. Check that the data register is clear, any set bits indicate an error
- . Repeat from step 5 for any additional remote parameter writes

Remote write byte, word, long and double are basically equivalent, the only difference being the LBP command (0x64,0x65,0x66,0x67 respectively) and the size of the data written to the interface register(s)

REFERENCE INFORMATION

SSLBP

DISCOVERY SEQUENCE:

for process data discovery (of one channel) the sequence of operations is as follows:

Note that the first section acquires the PTOC and the second section reads the records pointed to by the PTOC. For brevity, the remote read sequence (steps 5 through 9 of the remote read procedure) will be listed here as "remote read"

FIRST PART, ACQUIRE PTOC:

1. Issue a STOPALL (0x800) command, wait for COMMAND register clear to verify stop command completion.
2. Issue a setup START command (0xFNN) with bitmask (NN) of channels to start
3. Wait for COMMAND register clear to verify start command completion. (may be many mS)
4. Read data register to verify that the selected channels started (a 1 bit means a fault in the channel that the bit represents)
5. Read PTOCP from interface register 2, of selected channel, if zero, remote device does not support discovery
6. Remote read word at PTOCP
7. If word data is 0, PTOC collection is complete goto step 11
8. Save value in local PTOC table, and increment local PTOC table index
9. Increment PTOCP value by 2 (as it is a word pointer)
10. Repeat from step 6

REFERENCE INFORMATION

SSLBP

DISCOVERY SEQUENCE

SECOND PART, READ PROCESS DESCRIPTOR AND MODE DESCRIPTOR RECORDS:

11. For each PTOC entry acquired in the previous step:
12. Remote read byte at PTOC+0
12. If byte is 0xA0, proceed to step 16, reading process data descriptor
14. If byte is 0xB0, proceed to step 25 reading mode descriptor
15. If byte is neither, there is a error
16. Remote read byte at PTOC+1 This is DATA_SIZE
17. Remote read byte at PTOC+2 This is DATA_TYPE
18. Remote read byte at PTOC+3 This is DATA_DIRECTION
19. Remote read long at PTOC+4 This is PARAM_MIN.
20. Remote read long at PTOC+8 This is PARAM_MAX
21. Remote read word at PTOC+10 This is PARAM_ADD (not used normally)
22. Read UNIT_STRING starting at PTOC+12
 - Initialize CharPointer to PTOC+12
 - repeat (remote read byte at CharPointer, increment CharPointer, if byte is 0: done)
23. Read NAME_STRING starting at CharPointer
 - repeat (remote read byte at CharPointer, increment CharPointer, if byte is 0: done)
24. Repeat with next PTOC = step 11

REFERENCE INFORMATION

SSLBP

DISCOVERY SEQUENCE

SECOND PART, READ PROCESS DESCRIPTOR AND MODE DESCRIPTOR RECORDS:

25. Remote read byte at PTOC+1 This is MODE_INDEX

26. Remote read byte at PTOC+2 This is MODE TYPE

27. Read MODE_NAME_STRING starting at PTOC+4

 Initialize CharPointer to PTOC+4

 repeat (remote read byte at CharPointer, increment CharPointer, if byte is 0: done)

28. Repeat with next PTOC = step 1

29. Select next channel # and repeat from step 5

REFERENCE INFORMATION

LBP

LBP is a simple binary master slave protocol where the host sends read, write, or RPC commands to the 7176, and the 7176 responds. All controller communication to the 7176 is done via LBP. LBP commands always start with a command header byte. This header specifies whether the command is a read or write or RPC, the number of address bytes(0, or 2), and the number of data bytes(1 through 8).The 0 address size option indicates that the current address pointer should be used. This address pointer will be post incremented by the data size if the auto increment bit is set. RPC commands allow any of up to 64 stored commands to be executed in response to the single byte command.

Note that the low level serial interface details presented here are not normally needed for 7176 card access, as all the low level details are handed by the SSLBP code in the SSerial interface built into the FPGA, but is presented here for completeness.

LBP DATA READ/WRITE COMMAND

0	1	WR	RID	AI	AS	DS1	DS0
---	---	----	-----	----	----	-----	-----

- Bit 7.. 6 **CommandType:** Must be 01b to specify data read/write command
- Bit 5 **Write:** 1 to specify write, 0 to specify read
- Bit 4 **RPCIncludesData:** 0 specifies that data is from stream, 1, that data is from RPC (RPC only, ignored for non RPC commands)
- Bit 3 **AutoInc:** 0 leaves address unchanged, 1 specifies that address is post incremented by data size in bytes.
- BIT 2 **AddressSize:** 0 to specify current address, 1 to specify 2 byte address.
- Bit 1..0 **DataSize:** Specifies data size, 00b = 1 bytes, 01b = 2 bytes, 10 b= 4 bytes, 011b = 8 bytes.

When multiple bytes are specified in a read or write command, the bytes are always written to or read from successive addresses. That is, a 4 byte read at location 0x21 will read locations 0x21, 0x22, 0x23, 0x24. The address pointer is not modified after the command unless the AutoInc bit is set.

REFERENCE INFORMATION

LBP

EXAMPLE LBP COMMANDS

Write 4 bytes (0xAA, 0xBB,0xCC,0xDD) to addresses 0x010,0x011,0x012,0x013 with AutoInc so that the address pointer will be left at 0x014 when the command is completed:

COMMAND BITS	CT1	CT0	WR	RID	AI	AS	DS1	DS0
LBPWrite: 2 add 4 data	0	1	1	0	1	1	1	0
Write Address LSB	0	0	0	1	0	0	0	0
Write Address MSB	0	0	0	0	0	0	0	0
Write data 0	1	0	1	0	1	0	1	0
Write Data 1	1	0	1	1	1	0	1	1
Write Data 2	1	1	0	0	1	1	0	0
Write Data 3	1	1	0	1	1	1	0	1

Write 2 more bytes (0xEE,0xFF) at 0x014 and 0x015:

COMMAND BITS	CT1	CT0	WR	RID	AI	AS	DS1	DS0
LBPWrite: 0 add 2 data	0	1	1	0	0	0	0	1
Write data 0	1	1	1	0	1	1	1	0
Write data 1	1	1	1	1	1	1	1	1

Read 8 bytes at 0x010,0x011,0x012,0x013,0x014,0x015,0x016,0x017:

COMMAND BITS	CT1	CT0	WR	RID	AI	AS	DS1	DS0
LBPRead: 2 add 8 data	0	1	0	0	0	1	1	1
Read Address LSB	0	0	0	1	0	0	0	0
Read Address MSB	0	0	0	0	0	0	0	0

REFERENCE INFORMATION

LBP

LOCAL LBP COMMANDS

In addition to the basic data access commands, there are a set of commands that access LBP status and control the operation of LBP itself. These are organized as READ and WRITE commands

LOCAL LBP READ COMMANDS

(HEX), all of these commands return a single byte of data.

0xC0 Get unit address

0xC1 Get LBP status

LBP Status bit definitions:

BIT 7 Reserved

BIT 6 Command Timeout Error

BIT 5 Invalid write Error (attempted write to protected area)

BIT 4 Buffer overflow error

BIT 3 Watchdog timeout error

BIT 2 Reserved

BIT 1 Reserved

BIT 0 CRC error

0xC2 Get CRC enable status (note CRCs are always enabled on the 7176)

0xC3 Get CRC error count

0xC4 .. 0xC9 Reserved

0xCA Get Enable_RPCMEM access flag

0xCB Get Command timeout (character times/10 for serial)

0xCC .. 0xCF Reserved

0xD0 .. 0xD3 4 character card name

REFERENCE INFORMATION

LBP

LOCAL LBP READ COMMANDS

0xD5 .. 0xD7 4 character configuration name (only on some configurations)

0xD8 Get low address

0xD9 Get high address

0xDA Get LBP version

0xDB Get LBP Unit ID (Serial only, not used with USB)

0xDC Get RPC Pitch

0xDD Get RPC SizeL (Low byte of RPCSize)

0xDE Get RPC SizeH (High byte of RPCSize)

0xDF Get LBP cookie (returns 0x5A)

REFERENCE INFORMATION

LBP

LOCAL LBP WRITE COMMANDS

(HEX), all of these commands except 0xFF expect a single byte of data.

0xE0 Reserved

0xE1 Set LBP status (0 to clear errors)

0xE2 Set CRC check enable (Flag non-zero to enable CRC checking)

0xE3 Set CRC error count

0xE4 .. 0xE9 Reserved

0xEA Set Enable_RPCMEM access flag (non zero to enable access to RPC memory)

0xEB Set Command timeout (in mS for USB and character times for serial)

0xEC .. 0xEF Reserved

0xF0 .. 0xF6 Reserved

0xF7 Write LEDs

0xF8 Set low address

0xF9 Set high address

0xFA Add byte to current address

0xFB .. 0xFC Reserved

0xFD Set unit ID (serial only)

0xFE Reset LBP processor if followed by 0x5A

0xFF Reset LBP parser (no data follows this command)

REFERENCE INFORMATION

LBP

RPC COMMANDS

RPC commands allow previously stored sequences of read/write commands to be executed with a single byte command. Up to 64 RPC's may be stored. RPC write commands may include data if desired, or the data may come from the serial data stream. RPCs allow significant command compression which improves communication bandwidth. When used with SSLBP, the 7176s process data transfer uses an RPC for efficiency

LBP RPC COMMAND

1	0	RPC5	RPC4	RPC3	RPC2	RPC1	RPC0
---	---	------	------	------	------	------	------

Bit 7..6 **CommandType:** must be 10b to specify RPC

Bit 5..0 **RPCNumber:** Specifies RPC 0 through 63

In the 7176 LBP implementation, RPCPitch is 0x8 bytes so each RPC command has native size of 0x08 bytes and start 0x8 byte boundaries in the RPC table area. RPCs can cross RPCPitch boundaries if larger than RPCPitch RPCs are needed. The stored RPC commands consist of LBP headers and addresses, and possibly data if the command header has the RID bit set. RPC command lists are terminated by a 0 byte.

The RPC table is accessed at addresses 0 through RPCSize-1 This means with a RPCPitch of 0x8 bytes, RPC0 starts at 0x0000, RPC1 starts at 0x008, RPC2 starts at 0x0010 and so on.

Before RPC commands can be written to the RPC table, the RPCMEM access flag must be set. The RPCMEM access flag must be clear for normal operation.

REFERENCE INFORMATION

LBP

EXAMPLE RPC COMMAND LIST

This is an example stored RPC command list. Note RPC command lists must start at a RPCPitch boundary in the RPC table but an individual RPC list can extend until the end of the table. This particular RPC example contains 2 LBP commands and uses 7 bytes starting at 0x0028 (RPC5 for 0x08 pitch RPC table)

Command1. Writes two data bytes to address 0x10, 0x11 with 2 data bytes supplied by host

Command2. Reads two data bytes from address 0x12,0x13

COMMAND BITS	CT1	CT0	WR	RID	I	AS	DS1	DS0
LBPWrite: 2 add 2 data	0	1	1	0	0	1	0	1
Write Address LSB	0	0	0	1	0	0	0	0
Write Address MSB	0	0	0	0	0	0	0	0
LBPRead: 2 add 2 data	0	1	0	0	0	1	0	1
Read Address LSB	0	0	0	1	0	0	1	0
Read Address MSB	0	0	0	0	0	0	0	0
Terminator	0	0	0	0	0	0	0	0

The data stream for this RPC would consist of these 3 bytes:

COMMAND BITS	CT1	CT0	R5	R4	R3	R2	R1	R0
RPC 5	1	0	0	0	0	1	0	1
Data 0 for Command 1	0	1	0	1	0	1	0	1
Data 1 for Command 1	1	1	0	0	1	1	0	0

REFERENCE INFORMATION

SPECIAL RPCS

All remotes that work with SSLBP must implement three special RPCs, the ProcessDataRPC, The UnitNumberRPC, and the DiscoveryRPC.

DiscoveryRPC = 0xBB – Returns one byte that specifies process input data size in bytes, and one byte that specifies the process output data size in bytes. Following the size bytes are two 16 bit pointers, the first is the PTOC and the second is the GTOC. Note that the remote software mode must be set before issuing the discovery RPC.

UnitNumberRPC = 0xBC – Returns 32 bit unit number

ProcessDataRPC = 0xBD -- Normal process data transfer RPC followed by output data bytes. Returns one byte of remote fault information followed by input data. Number of input and output bytes are as specified in the DiscoveryRPC.

CRC

LBP on the 7176 uses CRC checking of all commands and data to insure validity. The CRC used is a 8 bit CRC using the same polynomial as the Dallas/Maxim one wire devices ($X^8+X^5+X^4+X^0$). The CRC must be appended to all LBP commands and all returned data will have a CRC byte appended. Commands with no returned data (writes or RPCs with no reads) will still cause a CRC byte to be returned, this CRC byte will always be 00H.

FRAMING

Since LBP is a binary protocol with no special sync characters, the packet framing must be determined by other methods.

Framing is done by a combination of timing and pre-parsing the serial data. Timing based framing is used to reset the parser at gaps in the serial data stream. This provides fast resynchronization to allow robust operation in noisy environments. The actual timeout used needs to be optimized for the operating mode. In setup mode where a non real-time OS may be communicating with the remote device, the frame timing is set to its maximum value (25.5 character times). This is equivalent to 2.1 mS at 115200 baud. This means that host communications cannot have more than 2.1 mS delays between characters in a command sequence when in setup mode.

In operate mode, command timeout is set by SSLBP to be 4 character times (16 uSec at 2.5M baud). The SSLBP firmware always sends commands in bursts without inter-character gaps so will always meet this timing. The timing is set short so that the parser on the remote device will always be reset and ready for the next command at the highest repetition rates even if data has been corrupted by noise so that incomplete commands have been received.

REFERENCE INFORMATION

SSERIAL REMOTE RPCS

SSerial remote devices must implement three special RPCs to be compatible with the hosts FPGA SSLBP firmware. These RPCs may be normal in-memory RPCs or special hardwired RPCs for speed. Normal programmable RPCs are not required for compatibility with SSLBP so need not be implemented.

UNIT NUMBER RPC

The unit number RPC returns the 4 byte remote unit number. Like all LBP data this is sent LSB first. This RPC is 0xBB hex.

DISCOVERY RPC

The discovery RPC returns the total sizes of the receive and transmit process data in bytes and returns 16 bit pointers to the PTOC and GTOC (which are in turn tables of pointers to process data records and mode records). The discovery RPC is 0xBC hex.

Return data bytes are in the following order: RXSize, TXSize, PTOCLSB, PTOCMSB, GTOCLSB, GTOCMSB.

RXSize is host relative so this is the size of data that the remote transmits. Likewise TXSize is host relative so this is the size of process data the remote receives. Note that the remote should check its remote SW mode and remote HW mode flags and return size data and pointers appropriate for the currently selected mode. Note that the remote always sends remote fault data as the first byte of the process data sent to the host. This extra byte of data must be reflected in the RXSize byte.

PROCESS DATA RPC

The Process data RPC is used to transfer process data to and from the host. The process data RPC should always receive and send the amount of RX and TX data that the Discovery RPC indicates. As mentioned above, the first byte of data sent from the remote to the host is always remote fault information as listed in CS REGISTER AFTER DOIT section of the manual. The process data RPC is 0xBD hex.

REFERENCE INFORMATION

SPECIFICATIONS

	MIN	MAX	NOTES
GENERAL			
HOST SUPPLY VOLTAGE 5V	4.5 VDC	5.5 VDC	
5V CURRENT	----	100 mA	No ext load.
STEP/DIR OUTPUTS			
STEP/DIR OUTPUT HIGH V	4V	----	10 mA source
STEP/DIR OUTPUT LOW V	----	1V	10mA sink
FIELD I/O			
VIN (FIELD I/O LOGIC POWER)	8VDC	32 VDC	
VIN POWER CONSUMPTION	----	1 W	Typ. 600 mW
FIELD POWER	5VDC	28VDC	
FIELD OUTPUT CURRENT	----	350 mA	Per output
(RESISTIVE LOADS AND INDUCTIVE LOADS WITH FLYBACK DIODE)			
FIELD OUTPUT CURRENT	----	60 mA	Per output
(INDUCTIVE LOADS WITH NO FLYBACK DIODE)			
PER DRIVER CHIP CURRENT	----	1.4A	Per chip
HIGH SPEED ENCODER INPUT			
INPUT COMMON MODE RANGE	-7	+12	Volts
INPUT TTL MODE THRESHOLD	1.4	1.8	Volts
DIFFERENTIAL MODE IMPEDANCE	131	135	Ohms
COUNT RATE	----	10 MHz	

SPECIFICATIONS

RS-422 INTERFACE

MAXIMUM DATA RATE	----	10	MBIT/S
INPUT COMMON MODE RANGE	-7	+12	Volts
INPUT TERMINATION RESISTOR	131	135	Ohm
OUTPUT LOW (24 mA sink)	----	.8	Volts
OUTPUT HIGH (24 mA source)	VCC-.8	----	Volts

SPINDLE INTERFACE

REFERENCE VOLTAGE	5	15	Volts
(SPINDLE+ -> SPINDLE-)			
SUPPLY CURRENT	----	20	mA
ISOLATION VOLTAGE	----	500	Volts DC
NON-LINEARITY	----	1	% at 5KHz
DIR/ENA OUTPUT CURRENT	----	50	mA
DIR/ENA OUTPUT VOLTAGE	----	100	Volts DC
DIR/ENA ISOLATION VOLTAGE	----	500	Volts DC

ENVIRONMENTAL

TEMPERATURE -C VERSION	0°C	70°C
TEMPERATURE -I VERSION	-40°C	85°C

DRAWINGS

REV A ONLY 2.150 ON REV B AND LATER

