

 **Allen-Bradley**

Smart Motor Manager

Bulletin 825

User Manual

**Rockwell
Automation**

Important User Information

Because of the variety of uses for the products described in this publication, those responsible for the application and use of this control equipment must satisfy themselves that all necessary steps have been taken to assure that each application and use meets all performance and safety requirements, including any applicable laws, regulations, codes and standards.

The illustrations, charts, sample programs and layout examples shown in this guide are intended solely for purposes of example. Since there are many variables and requirements associated with any particular installation, Allen-Bradley does not assume responsibility or liability (to include intellectual property liability) for actual use based upon the examples shown in this publication.

Allen-Bradley publication SGI-1.1, *Safety Guidelines for the Application, Installation and Maintenance of Solid-State Control* (available from your local Allen-Bradley office), describes some important differences between solid-state equipment and electromechanical devices that should be taken into consideration when applying products such as those described in this publication.

Reproduction of the contents of this copyrighted publication, in whole or part, without written permission of Rockwell Automation, is prohibited.

Throughout this manual we use notes to make you aware of safety considerations:

ATTENTION

Identifies information about practices or circumstances that can lead to personal injury or death, property damage or economic loss



Attention statements help you to:

- identify a hazard
- avoid a hazard
- recognize the consequences

IMPORTANT

Identifies information that is critical for successful application and understanding of the product.

Allen-Bradley is a trademark of Rockwell Automation

European Communities (EC) Directive Compliance

If this product has the CE mark it is approved for installation within the European Union and EEA regions. It has been designed and tested to meet the following directives.

EMC Directive

This product is tested to meet the Council Directive 89/336/EC Electromagnetic Compatibility (EMC) by applying the following standards, in whole or in part, documented in a technical construction file:

- EN 50081-2 EMC — Generic Emission Standard, Part 2 — Industrial Environment
- EN 50082-2 EMC — Generic Immunity Standard, Part 2 — Industrial Environment

This product is intended for use in an industrial environment.

Low Voltage Directive

This product is tested to meet Council Directive 73/23/EEC Low Voltage, by applying the safety requirements of EN 61131-2 Programmable Controllers, Part 2 - Equipment Requirements and Tests. For specific information required by EN 61131-2, refer to the appropriate sections in this publication, as well as the Allen-Bradley publication Industrial Automation Wiring and Grounding Guidelines For Noise Immunity, publication 1770-4.1.

This equipment is classified as open equipment and must be mounted in an enclosure during operation to provide safety protection.

ATTENTION

In order to achieve maximum performance from this product, correct transport, proper and competent storage and installation, and careful operation and maintenance must be observed.

- The power supply must be switched off prior to any intervention in the electrical or mechanical part of the equipment!
 - In accordance with applicable rules, work on electrical equipment or means of production may only be carried out by competent electricians or suitably trained persons guided and supervised by a competent electrician.
 - The electrical equipment of a machine/plant must be inspected/ tested. Deficiencies, such as loose connections or scorched cables, must be eliminated immediately.
 - The Bulletin 825 Smart Motor Manager features supervision and protection functions that can automatically switch devices off, bringing motors to a standstill. Motors can also be stopped by mechanical blockage, as well as mains failures and voltage fluctuations.
 - In case of functional disturbances, the machine/plant must be switched off and protected and the disturbance eliminated immediately.
 - The elimination of a disturbance may cause the motor to restart. This may endanger persons or damage equipment. The user must take the necessary safety measures to avoid this type of occurrence.
 - Sufficient safety distance must be maintained where wireless equipment (walkie-talkies, cordless and mobile phones) is used.
-

Table of Contents

Chapter 1 — Introduction

Why Have an Electronic Control and Protection System?	1-1
Operational Demands of the Motor/Drive	1-2
Temperature Rise	1-2
Motor Operating Characteristics	1-2
Current and Temperature Curves.....	1-3
Limiting Temperatures, Insulation Classes	1-4
Operational Requirements for Installation	1-5
Personnel and Installation Safety	1-6
Bulletin 825 Smart Motor Manager as an Automation Component	1-6

Chapter 2 — Equipment Description

System Structure.....	2-1
System Components	2-1
Installation.....	2-1
Modular Design.....	2-2
Block Diagram.....	2-3
Operating Elements.....	2-4
Specifications — Basic Unit and Converter Module	2-5
Standards.....	2-7
Main Current Transformers for the Motor Circuit	2-10
Core Balance Current Transformer	2-11
Short-Circuit Protection	2-11
Response Supply Voltage Failure.....	2-12
Automatic Recognition of Converter Module	2-13

Chapter 3 — Functions

Menu Overview	3-1
Actual Values.....	3-1
Set Values	3-2
Recorded Values	3-3

Operation	3-4
Selecting the Setting/Display Mode.	3-4
Setting the Operation Parameters (Set Values)	3-5
Indications of Actual Values.	3-7
Indications of Recorded Values (Statistics)	3-8
<i>Test</i> Button.	3-9
Function Summary.	3-13
Functions of the Basic Unit (Cat. No. 825-M...)	3-16
Thermal Overload.	3-16
Adjustable Ratio of Cooling Constants	3-17
Indication of the Time to Tripping	3-18
Indication of the Time until the Thermal Trip can be Reset	3-18
Adjustable Setting Characteristic	3-18
Asymmetry (Phase Unbalance) and Phase Failure	3-22
High Overload and Jam	3-23
Underload	3-25
Earth (Ground) Fault	3-27
Limiting the Number of Starts per Hour (Start Lockout).	3-33
Monitoring the Starting Time.	3-34
Warm Start.	3-35
Emergency Override of Thermal Trip (Emergency Start)	3-38
LED Alarm and Trip Indicator	3-39
Connection of the Main Relay (MR)	3-40
Connection of the Alarm Relay (AL)	3-40
Alarm Relay AL.	3-41
Reset.	3-42
Function of the Cat. No. 825-MST Option Card.	3-42
Short-Circuit	3-42
Earth (Ground) Fault Protection with a Core Balance Current Transformer.	3-44
Stalling During Start	3-44
PTC Thermistor Input	3-46
Analog Output	3-48
Analog Output for Thermal Load or Motor Temperature (PT100 Max.)	3-48
Analog Output for Motor Current.	3-50
Control Inputs #1 and #2	3-51
Switching to a Second Rated Current	3-53

Functions of the Cat. No. 825-MLV Option Card	3-53
Phase Sequence	3-53
Phase Failure (Based on Voltage Measurement)	3-54
Star-Delta (Wye-Delta) Starting	3-55
Functions of the Cat. No. 825-MMV Option Card	3-56
PT100 (100 Ω Platinum) Temperature Sensor (RTD)	3-56
PT100 #7 Temperature Sensor (RTD)	3-57

Chapter 4 — Assembly and Installation

Assembly	4-1
Flush Mounting	4-1
Mounting Position	4-2
Surface Mounting	4-2
Converter Modules	4-3
Thermal Utilization Indicator	4-4
Installation and Wiring	4-5
General	4-5
Main Circuits	4-6
Control Circuits	4-8

Chapter 5 — Setting the Operational Parameters

Menu Overview	5-1
Main Settings	5-1
Special Settings	5-2
Operating Parameters	5-4

Chapter 6 — Commissioning and Operation

Checking the Installation	6-1
Checking the Wiring	6-2
Checking the Installation with the Control Voltage Applied	6-2
Switching on the Control Voltage	6-2
Checking the Set Parameters	6-2
Motor Current	6-3
Locked Rotor or Starting Current	6-4
Locked Rotor Time	6-4

Programming, Setup, and Operation	6-5
Starting	6-5
Operating	6-6

Chapter 7 — Testing and Maintenance

General	7-1
Checking without Test Equipment	7-1
Functional Check with the <i>Test</i> Button	7-1
Indication of Recorded Values	7-2
Checking with Test Equipment	7-5
Test Unit	7-5

Chapter 8 — Error Diagnosis and Troubleshooting

Alarm, Warning	8-1
Procedure when Alarm/Warning Picks Up	8-1
Trip	8-2
Fault Codes	8-3
Procedure if “ALARM” does not Reset	8-8
Procedure if “TRIP” cannot be Reset	8-8

Chapter 9 — Applications/Wiring

Bulletin 825 Smart Motor Manager with Contactors	9-1
Main Circuit	9-1
Control Circuit	9-2
Star-Delta Starter with Bulletin 825 Smart Motor Manager	9-3
Main Circuit	9-3
Control Circuit	9-3
Short-Circuit Protection of Medium/High-Voltage Motors	9-4
Main Circuit (with Cat. No. 825-MST Option Card)	9-4
Control Circuit	9-5
Two-Speed Motors	9-5
Main Circuit	9-6
Two-Speed Motor: 0.5 A < Speed I < 20 A < Speed II < 180 A	9-7
Main Circuit	9-7
Two-Speed Motors with Primary Current Transformer	9-8
Primary Circuit	9-8
Separately Ventilated Motors	9-8

Basic Unit and Converter Module with Primary Current Transformer and Core Balance Current Transformer	9-9
Main Circuit.	9-9
Basic Unit and Converter Module with Core Balance Current Transformer	9-10
Main Circuit.	9-10
Motors with Low Idling Current ($< 20\% I_e$)	9-11
Main Circuit.	9-11
Connecting the PT100 Temperature Sensors Using the 2/3/4-Conductor Technique	9-12
Basic Unit and Converter Module with Primary Current Transformer, 2-Phase Current Evaluation.	9-13
Time/Current Characteristic of Bulletin 825 Smart Motor Manager . . .	9-14

Chapter 10 — References

Figures

Figure 1.1	Bulletin 825 Smart Motor Manager.	1-1
Figure 1.2	Operating Characteristics of an AC Motor.	1-3
Figure 1.3	AC Current Profile of a Motor Starting Direct-on-Line	1-4
Figure 1.4	Temperature Rise Characteristics of Motor Windings.	1-4
Figure 1.5	Reduction in Average Life (EM) of a Motor when Winding is Continuously Overheated.	1-5
Figure 2.1	Modular Design of the Bulletin 825 Smart Motor Manager	2-2
Figure 2.2	Block Diagram	2-3
Figure 2.3	Front View with Operating Elements.	2-4
Figure 3.1	Setting Mode.	3-5
Figure 3.2	Menu Selection.	3-5
Figure 3.3	Entering a Data Value	3-6
Figure 3.4	Selecting the Actual Values	3-7
Figure 3.5	Selecting Recorded Data	3-8
Figure 3.6	Basic Unit <i>Test</i> Button	3-9
Figure 3.7	Two-Body Simulation of the Heating Up of a Motor.	3-17
Figure 3.8	Trip Characteristic (10...30 s)	3-19

Figure 3.9	Trip Characteristics (40...100 s)	3-20
Figure 3.10	Reduction in Permissible Motor Output Due to Voltage Asymmetry per IEC and NEMA	3-23
Figure 3.11	Function of High Overload and Jam Protection	3-24
Figure 3.12	Function of Underload Protection	3-26
Figure 3.13	3-Phase Current Detection	3-27
Figure 3.14	Example of 2-Phase Current Sensing	3-28
Figure 3.15	Isolated Network: Earth Fault on the Network Side	3-31
Figure 3.16	Network Earthed through a High Impedance Earth Fault on the Network Side	3-31
Figure 3.17	Isolated network: Earth (Ground) Fault on the Leads on the Motor Side	3-32
Figure 3.18	Network Earthed through a High Impedance: Earth (Ground) Fault on the Motor Leads.	3-32
Figure 3.19	Isolated Network: Earth (Ground) Fault in the Motor	3-32
Figure 3.20	Network Earthed through a High Impedance: Earth (Ground) Fault on the Motor	3-32
Figure 3.21	Limiting the Number of Starts per Hour	3-33
Figure 3.22	Monitoring Starting Time	3-34
Figure 3.23	Current and Temperature Curves for Warm and Cold Motor Starts and the Smart Motor Manager Tripping Limits.	3-36
Figure 3.24	Example for $t6xI_c = 10$ s and Warm Trip Time = 70%	3-37
Figure 3.25	Interruption of a Short-Circuit	3-43
Figure 3.26	Stalling During Starting	3-45
Figure 3.27	Characteristic of PTC Sensors as per IEC 34-11-2	3-48
Figure 3.28	Analog Output for Motor Temperature Rise	3-49
Figure 3.29	Analog Output for Motor Temperature	3-50
Figure 3.30	Analog Output for Motor Current	3-50
Figure 3.31	Operating Diagram for Timer Functions	3-52
Figure 3.32	Diagram of Star-Delta (Wye-Delta) Starting.	3-55
Figure 4.1	Basic Unit Mounted in an Enclosure	4-1
Figure 4.2	Mounting Position	4-2
Figure 4.3	Basic Unit Mounted into Panel Mounting Frame (Cat. No. 825-FPM)	4-2

Figure 4.4	Cat. Nos. 825 MCM2, 825-MCM-20, 825-MCM180 . . .	4-3
Figure 4.5	Cat. Nos. 825-MCM630, 825-MCM630N	4-3
Figure 4.6	Cat. No. 825-MTUM Thermal Utilization Indicator . . .	4-4
Figure 4.7	Basic Unit Housing with Option Cards	4-5
Figure 4.8	Basic Unit with Converter Module	4-6
Figure 4.9	3-Phase Current Evaluation.	4-6
Figure 4.10	2-Phase Current Evaluation.	4-7
Figure 4.11	Smart Motor Manager Basic Unit	4-8
Figure 4.12	Cat. No. 825-MST Option Card	4-9
Figure 4.13	Cat. No. 825-MLV Option Card.	4-10
Figure 4.14	Cat. No. 825-MMV Option Card	4-11
Figure 6.1	Range of Starting Currents of Standard Motors Expressed as Multiple of the Rated Service Current	6-4
Figure 7.1	Test with a 3-Phase Current Source	7-5
Figure 7.2	Test with a Single-Phase Current Source	7-6
Figure 9.1	Basic Unit and Converter Module.	9-1
Figure 9.2	Control by Momentary Contact	9-2
Figure 9.3	Basic Unit and Converter Module.	9-3
Figure 9.4	Control by Momentary Contact	9-3
Figure 9.5	Basic Unit for Short-Circuit Protection	9-4
Figure 9.6	Control by Momentary Contact	9-5
Figure 9.7	Two-Speed Application Utilizing One 825-MCM*	9-6
Figure 9.8	Two-Speed Application Utilizing 825-MCM180	9-7
Figure 9.9	Two-Speed Application Utilizing Primary Current Transformer	9-8
Figure 9.10	Typical Application Utilizing Primary Current Transformers and Core Balance Current Transformer	9-9
Figure 9.11	Typical Application Utilizing Core Balance Current Transformer	9-10
Figure 9.12	Application with Low Idling Current	9-11
Figure 9.13	2/3/4 Conductor Technique for PT100 Wiring	9-12
Figure 9.14	Typical Application Utilizing 2-Phase Current Evaluation with Primary Current Transformers.	9-13
Figure 9.15	Trip Characteristics	9-14

Tables

Table 2.A	Environmental Ratings	2-5
Table 2.B	Nominal Rated Voltages U_c	2-6
Table 2.C	Electrical Ratings	2-6
Table 2.D	Supply Ratings	2-7
Table 2.E	Relay Ratings	2-8
Table 2.F	Terminals	2-9
Table 2.G	Main Current Transformer Ratings.	2-10
Table 2.H	Recommended Data for Core Balance Current Transformer	2-11
Table 2.I	Converter Module — Related Error Messages.	2-13
Table 3.A	Actual Values Overview.	3-1
Table 3.B	Set Values Overview	3-2
Table 3.C	Recorded Values Overview	3-3
Table 3.D	Display Example of Set Values Menu.	3-6
Table 3.E	Display Example of Actual Values Menu.	3-7
Table 3.F	Display Example of Recorded Values.	3-9
Table 3.G	Protective Functions Summary	3-13
Table 3.H	Warning Functions Summary	3-14
Table 3.I	Control Functions Summary	3-15
Table 3.J	Thermal Overload Setting Parameters	3-21
Table 3.K	Protection Against Thermal Overload	3-22
Table 3.L	Asymmetry (Phase Unbalance) Setting Parameters	3-23
Table 3.M	High Overload and Jam Setting Parameters.	3-24
Table 3.N	Underload Setting Parameters	3-26
Table 3.O	Earth (Ground) Fault — Holmgreen/Residual Setting Parameters	3-28
Table 3.P	Core Balance Current Transformer Setting Parameters	3-29
Table 3.Q	Earth (Ground) Fault Core Balance Setting Parameters	3-29
Table 3.R	Starts per Hour Setting Parameters.	3-33
Table 3.S	Monitoring Start Time Setting Parameters	3-35
Table 3.T	Warm Start Setting Parameters	3-38
Table 3.U	Alarm Examples.	3-41
Table 3.V	Reset Setting Parameters	3-42
Table 3.W	Short Circuit Setting Parameters	3-44

Table 3.X	Stalling during Start Setting Parameters	3-45
Table 3.Y	PTC Setting Parameters	3-46
Table 3.Z	Sensor Measuring Circuit Specifications	3-47
Table 3.AA	Phase Sequence Setting Parameters	3-54
Table 3.AB	Phase Failure Setting Parameters	3-54
Table 3.AC	Star-Delta (Wye-Delta) Starting Setting Parameters	3-55
Table 3.AD	PT100 Temperature Detector Resistance per IEC 751	3-56
Table 3.AE	PT100 (RTD) Setting Parameters	3-57
Table 3.AF	Motor Insulation Class Setting Parameters	3-58
Table 4.A	Cat. Nos. 825-MCM2, 825-MCM-20, 825-MCM180	4-3
Table 4.B	Cat. Nos. 825-MCM630, 825-MCM630N	4-4
Table 4.C	Specifications	4-7
Table 5.A	Main Settings	5-1
Table 5.B	Special Settings	5-2
Table 5.C	Communication Settings	5-3
Table 5.D	Cat. No. 825-M... Operating Parameters	5-4
Table 6.A	Checking the Actual Values	6-6
Table 7.A	List of Recorded Values	7-2
Table 8.A	Possible Causes and Actions	8-3

Notes:

Introduction

Why Have an Electronic Control and Protection System?

The need to optimize production facilities requires enhanced control, monitoring, and protection systems.

Motor and installation use must be maximized while minimizing both the downtime required for maintenance and that caused by motor failures; these requirements are easily met by the microprocessor-based Bulletin 825 Smart Motor Manager.

The Bulletin 825 Smart Motor Manager has a modular design and is easily programmed. Its attributes enable an optimum fit to a wide variety of motor and installation requirements.

The Bulletin 825 Smart Motor Manager provides continuous monitoring of motor operating data in one of two ways. The data can be viewed directly on the unit or it can be monitored remotely via a network by using a PC or process computer. The main statistical data can also be accessed at any time.

Figure 1.1 Bulletin 825 Smart Motor Manager



Operational Demands of the Motor/Drive

Temperature Rise

Motor designs and applicable standards require that, when a motor is operated under specified loads and ambient conditions, the critical parts of the motor will remain within an allowable temperature range and short-term overloads will not harm the motor.

The device protecting the motor must permit full use of the motor and its economical operation. At the same time, the protective device must switch off rapidly if an overload occurs.

Motor Operating Characteristics

Electric motors absorb electrical energy and supply mechanical energy. During this energy conversion, losses are produced in the form of heat. The total loss consists of the following separate losses:

- Losses independent of the current (these losses are virtually constant i.e., they also occur at no load)
 - Iron losses caused by remagnetization and eddy currents
 - Mechanical losses caused by friction and ventilation
- Losses dependent on the current (these losses increase with load i.e., with the current consumed by the motor)
 - Heat losses caused by the current in the stator
 - Heat losses caused by the current in the rotor
- Increased temperature rise caused by poor cooling (e.g., cooling fins are dusty or damaged, coolant temperature is too high)

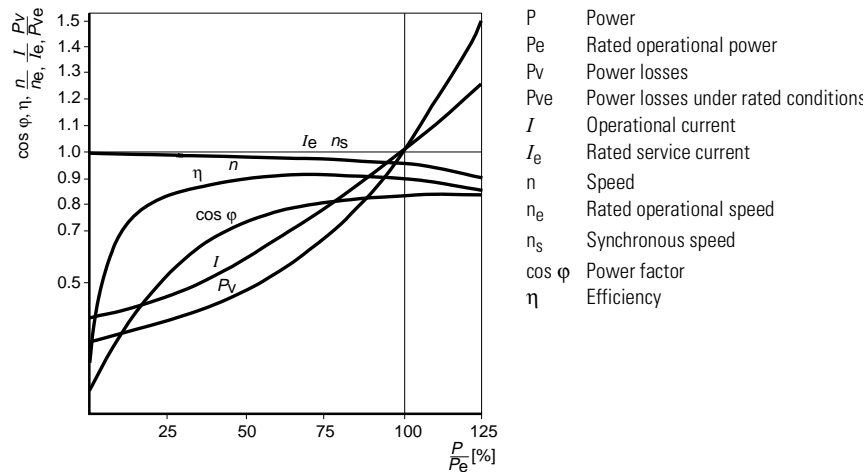
Figure 1.2 Operating Characteristics of an AC Motor

Operating characteristics of an AC motor as a function of load. Between no load and half load, the losses increase only slightly with rising load. Between half load and rated load, the change in efficiency is minimal, and the power factor approaches its maximum. The losses increase approximately proportional to the load. Above rated load, the losses increase more rapidly than the load.

Current and Temperature Curves

Power loss is approximately proportional to the square of the motor current. The potential for motor hazards exists mainly during starting and in a locked rotor condition. When a locked rotor condition exists, the maximum value of the starting current flows (approximately 4...8 times the rated service current I_e), and all of the power absorbed is converted into heat. As the motor speed increases, the power converted into heat decreases. But if the rotor remains locked, the temperature of the stator and rotor windings rises considerably, caused by the high losses and the short time that heat can flow into the laminated core. If the motor is not switched off quickly, the stator or rotor winding can burn out.

After startup, the temperature of the winding rises according to the load and cooling of the motor. In time, the winding reaches its steady-state value.

A high current results in a correspondingly high operating temperature.

Figure 1.3 AC Current Profile of a Motor Starting Direct-on-Line

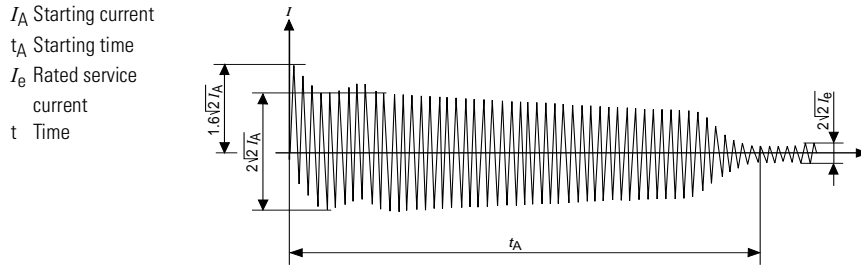

Oscillogram of switching on a squirrel-cage induction motor by direct-on-line starting. The high motor starting current I_A flows during the starting time (t_A). If this is less than the limit specified by the manufacturer (usually 10 s), the starting current does not cause an excessive temperature rise. The brief, asymmetrical peak when switching on can be ignored.

Motors are not thermally homogeneous. The winding, stator iron, and rotor have different heat capacities and conductivities. Following unduly heavy loads, e.g., during starting, temperature equalization occurs between the various parts of the machine (heat flows from the warmer winding into the cooler iron until the temperature difference is minimal).

Figure 1.4 Temperature Rise Characteristics of Motor Windings

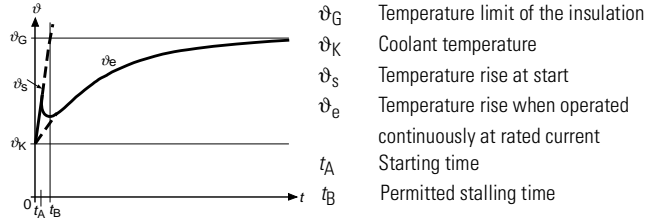

Temperature rise in a motor winding. During the starting time (t_A), the temperature of the winding rises very rapidly; at the end of startup, the temperature drops temporarily because heat is transferred to the laminated core.

Limiting Temperatures, Insulation Classes

The permissible temperature limit for a winding — and thus the load-bearing capacity — of the motor is primarily a function of the motor's insulation. Applicable standards (UL, CSA, IEC, and NEMA) distinguish between different classes of insulation and corresponding temperature limits.

Insulation Aging

The aging of insulation material is a chemical process that is accelerated by continuous overtemperature. It may be assumed that a winding temperature that is constantly 10 K higher than the temperature limit reduces the motor life by half. This “life law” shows that particular attention must be paid to adhering to the permitted operating temperature for long periods of time. (Note that overtemperatures of short duration and infrequent occurrence do not seriously affect the life of the machine.)

The Bulletin 825 Smart Motor Manager's ability to accurately limit excessive current conditions greatly aids in extending motor life. In practice, it may be expected that there will be reduced loads and pauses, so that when the temperature limit is reached, the motor life will not be impaired.

Figure 1.5 Reduction in Average Life (E_M) of a Motor when Winding is Continuously Overheated

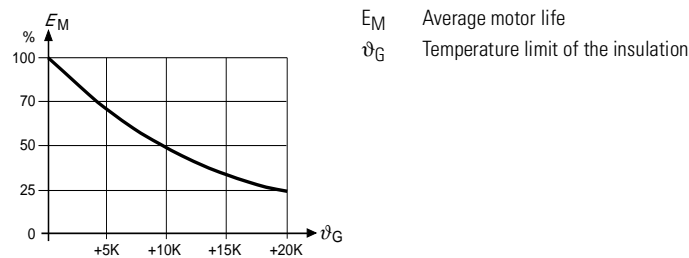

Rotor Temperature

The rotors of squirrel-cage induction motors with simple construction (no insulation) may continuously attain higher temperatures than rotors in motors with insulated windings. However, in larger motors, the concentration of the rotor losses during starting is higher than the concentrations of losses in other parts of the motor. The starting time of such motors is therefore limited by the thermal capacity of the rotor. These types of motors are commonly referred to as “rotor-critical” motors. Critical to the rotor are the mechanical stresses caused by the temperature rise, unsoldering of the rotor bars, and, for EExe motors (motors for use in the chemical industry), the high temperature as a source of ignition.

Operational Requirements for Installation

Monitoring the application parameters and process data of an installation can be very important. Even a slight change in the starting and operating behavior of the motor can indicate an impending fault. The Smart Motor Manager helps eliminate potential trouble before major repairs are necessary and loss of production occurs.

The Smart Motor Manager fulfils these requirements by providing protection against the following:

- high overload, stalling and jam
- underload
- phase sequence

Personnel and Installation Safety

Personnel protection in the vicinity of control equipment is of primary importance. The corresponding requirements of regulatory agencies are therefore becoming increasingly severe. The Smart Motor Manager reflects this by providing the following protection:

- equipment construction
 - touch protection
 - insulated housing
- motor protective functions:
 - Earth (ground) fault
 - High overload, stalling and jam
 - Wrong direction of rotation

Bulletin 825 Smart Motor Manager as an Automation Component

The Bulletin 825 Smart Motor Manager detects abnormal operating conditions and faults in motor branch circuits. The data made available by the Smart Motor Manager can be used for operational control and optimization of the installation.

A large number of supervisory, protective, and control functions improve operational control and avoid unnecessary downtime. This maximizes your motor investment, making the Smart Motor Manager a valuable component in modern automation systems.

Equipment Description

System Structure

The Bulletin 825 Smart Motor Manager is a microprocessor-based protection and control system for motors. For the AC motor and the operated installation this means:

- Maximum utilization
- Continuous supervision
- Reliable protection

The modular structure of the system and all of its possible functions enable the Bulletin 825 Smart Motor Manager to be economically and optimally adapted to any installation.

System Components

The motor protection system consists of:

- The basic control and protection unit
- Current converter modules for 0.5...630 A
- Cable for connecting between the basic unit and the current converter module
- Optional plug-in printed circuit boards
- Thermal utilization meter to indicate the thermal load

Installation

The Smart Motor Manager can be either flush mounted in an enclosure door, or surface mounted to the enclosure mounting plate using a panel mounting frame.

Current converter modules can be surface mounted.

Modular Design

The Cat. No. 825-M basic unit can be fitted with additional option (function) cards to suit the requirements.

Figure 2.1 Modular Design of the Bulletin 825 Smart Motor Manager

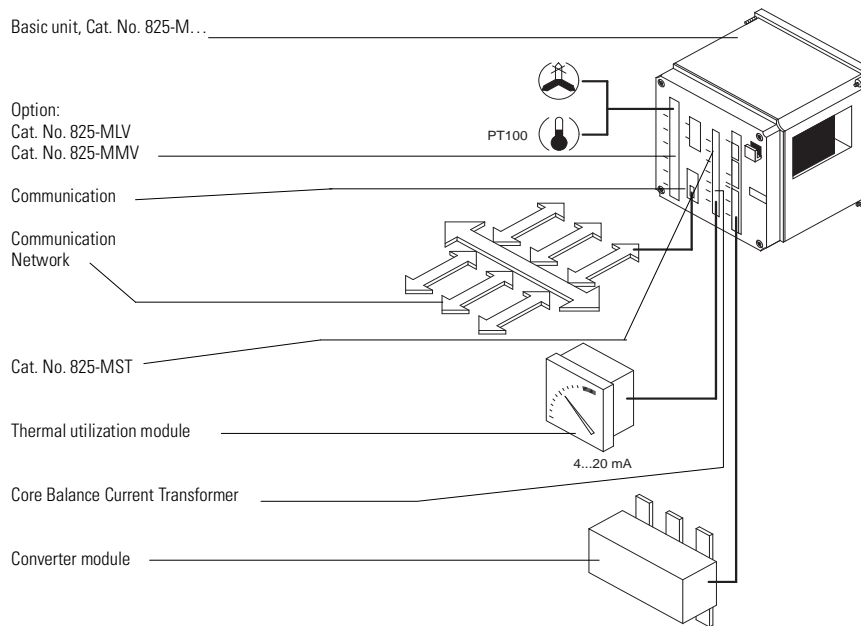

Available Communications Cards

Cat. No. 825-MDN: DeviceNet

Cat. No. 3600-RIO: Remote I/O ❶

Cat. No. 3600-MBS: Modbus ❶

Cat. No. 825-MPB: PROFIBUS FMS

❶ Available from Prosoft Technology, Inc. (not an Allen-Bradley product). References to third-part products are provided for informational purposes only. Prosoft Technology, Inc., is solely responsible for the accuracy of information, supply, and support of this product. For further information regarding this particular referenced product, please contact Prosoft Technology, Inc., in the U.S. at (661) 664-7208 or your local Prosoft Technology, Inc. distributor.

Block Diagram

Figure 2.2 Block Diagram

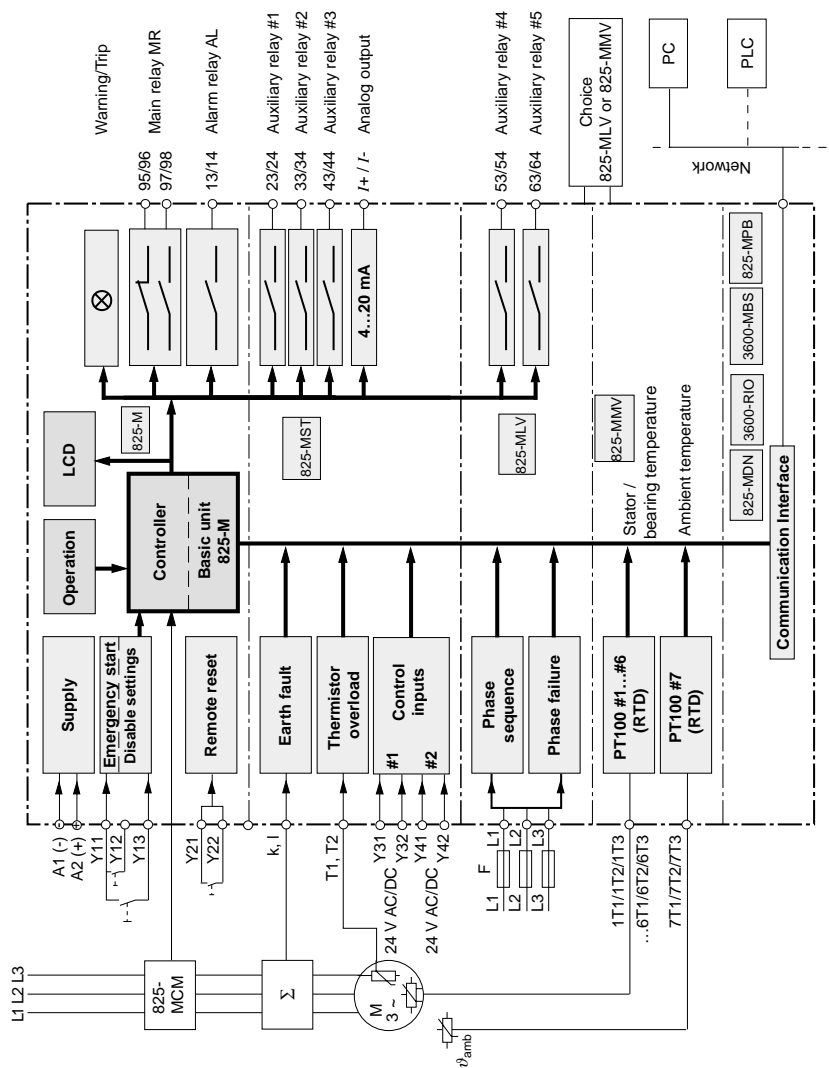

Operating Elements

The Smart Motor Manager is very easy to operate. All functions, data, and tests can be entered, executed, or displayed using the six membrane keys and the single-line LCD, which displays all available data and functions.

Figure 2.3 Front View with Operating Elements



- ❶ Fault indicator (LED)
Flashing: warning
Steady state: trip
- ❷ LCD: Single line (two lines of text are displayed alternately)
- ❸ Values: Selection of mode
Actual: Indication of actual operational data
Set: Setting mode (set/modify, store parameters)
Recorded: Indication of statistical data
- ❹ Select: Select function and enter/change operating parameter
- ❺ Settings: Enable entry (Change) and memorize (Enter)
- ❻ Test: Verifies operation of Smart Motor Manager.
- ❼ Reset: Enables the Smart Motor Manager after a trip.

Specifications — Basic Unit and Converter Module

Table 2.A Environmental Ratings

Temperature	
Operation	-5...+ 60 °C (23...140 °F)
Storage	-40...+ 60 °C (-40...140 °F)
Transport	-40...+ 85 °C (-40...185 °F)
Climatic Withstand	
Damp heat IEC 68-2-3	40 °C (104 °F), 92% relative humidity, 56 days
Climatic cycling IEC 68-2-30	25/40 °C (77/104 °F), 21 cycles
Enclosure Protection Class	
825-M, enclosed in panel	IP65
Terminals	IP20
Resistance to Vibration	
as per IEC 68-2-6	10...150 Hz, 3 G
Resistance to Shock	
as per IEC 68-2-27	30 G, shock duration 18 ms, half a sine wave in x, y, z directions

Table 2.B Nominal Rated Voltages U_e

Primary Detection Circuit	825-MCM2	825-MCM20	825-MCM180 MCM630 MCM630N
Motor Circuit			
as per IEC, SEV, VDE 0660	400V AC	660V AC	1 000V AC
as per CSA, UL	240V AC	600V AC	600V AC
Control Circuit			
Main relay (MR) 95...98, supply A1, A2			
Phase sequence protection L1, L2, L3			
as per IEC 947		400V AC	
as per SEV		380V AC	
as per UL, CSA		240V AC	
Alarm relay (AL) 13/14			
Auxiliary relay #1, #4, #5			
as per IEC 947		400V AC	
as per SEV		250V AC	
as per UL, CSA		240V AC	
Auxiliary relays #2, #3		50V AC/30V AC	
Control inputs #1, #2		24V AC/DC	

Table 2.C Electrical Ratings

Test Voltage	825-MCM2	825-MCM20	825-MCM180 MCM630	825-MCM630N
Motor Circuit				
as per IEC 947-1	U_{imp} 2.5 kV	U_{imp} 6 kV	U_{imp} 8 kV	U_{imp} 12 kV
Control Circuit				
Between control circuits and to all other circuits ❶ Main relay (MR) 95...98, supply A1, A2 Phase sequence protection L1, L2, L3 Alarm relay (AL), auxiliary relay #1, #4, #5 as per IEC 947-4			U_{imp} 4 kV	
Core balance current transformer k, l Control inputs #1, #2 Auxiliary relays #2, #3 as per IEC 947-4			U_{imp} 2.5 kV	

- ❶ The measuring inputs for PT100 and PTC, the 4...20 mA output, and the communication interface are not isolated from one another.

Standards

EMC

Noise emission as per EN 50 081-1 and as per EN 50 081-2

Noise proof as per EN 50 082-1 and as per EN 50 082-2

Standards: IEC 947-4, CSA C22.2 No. 14, UL 508

Approvals: CE, UL-Listed, CSA, PTB: **Physikalisch-Technische Bundesanstalt** (Germany):

Certification required for motor protection in explosion hazard area (e.g., Chemical, Petrochemical Installations).

Table 2.D Supply Ratings

Nominal supply voltage U_S	50/60 Hz, 22...24, 33...36, 44...48, 110...120, 220...240, 380...415, 440V AC 24...48, 72...120, 220V DC
Permissible voltage fluctuation	AC 0.85...1.10 U_S DC 0.80...1.10 U_S for 24...48V DC DC 0.80...1.20 U_S for 72...120V DC DC 0.80...1.15 U_S for 220V DC
Power consumption	AC 13 VA, DC 10 W max.
Short-circuit protection	With the appropriate supply cable rating, the supply module is short-circuit proof.

Table 2.E Relay Ratings

Contact Data of Output Relays					
Main Relay (MR) 95...96					
Contacts fitted		1 N/C and 1 N/O contact, galvanically separated			
Nominal operating voltage as per UL, CSA: pilot duty 240 V	[V]	24	110...125	220...250	380...440
Continuous thermal current	[A]	4			
Rated operating current for AC-15	[A]	3		3	1.2
Max. permissible switching current (cos φ = 0.3) AC-15	[A]	30		30	12
Rated operating current for DC-13 without prot. network, L/R = 300 ms	[A]	2	0.3	0.2	–
Max. rated current of back-up fuse:	[A]	10 A, 500V AC, Type gG			
Alarm Relay (AL), Auxiliary Relays #1, #4, #5					
Contacts fitted		1 N/O contact each			
Continuous thermal current		4 A			
Max. permissible switching voltage		400V AC, 125 VDC			
Nominal Operating Current					
cos φ = 1		4 A at 250V AC or 30V DC			
cos φ = 0.4, L/R = 7 ms		2 A at 250 VAC or 30V DC			
Max. Switching Power					
cos φ = 1		1 250 VA, 150 W			
cos φ = 0.4, L/R = 7 ms		500 VA, 60 W			
as per UL/CSA		240 V, 1 A pilot duty			
Auxiliary Relays #2, #3					
Contacts fitted		1 N/O contact each			
Continuous thermal current		4 A			
Max. permissible switching voltage		48 VAC, 30 VDC			
Max. Switching Power					
cos φ = 1		150 W			
cos φ = 0.4, L/R = 7 ms		60 W			

Table 2.F Terminals

Cat. No. 825-M plug-in terminals as per UL as per VDE	Range of gauges: 0.5...2.5 m ² , single wire (AWG No. 20...14) 0.5...1.5 m ² double wire (AWG No. 20...16) AWG No. 22...14 nominal gauge 1.5 mm ²
Main circuit 825-MCM2/ 825-MCM20 825-MCM180 825-MCM630(N)	Terminals: 2 x 2.5 mm ² /1 x 4 mm ² (2 x 0.0039 in ² /1 x 0.006 in ²) 2 x AWG No. 20...14/1 x AWG No. 20...12 Aperture or busbars: Wire Ø 19 mm max. 20/16 x 4 mm Bus bars: 25 x 8 mm

Main Current Transformers for the Motor Circuit

When the Cat. No. 825-M Control and Protection Unit is used as a secondary relay with Cat. Nos. 825-MCM2 and 825-MCM20, the following specifications apply:

Table 2.G Main Current Transformer Ratings

Minimum nominal operating voltage	Nominal operating voltage of motor	
Minimum rated primary current I_{1N}	Nominal operating current of motor	
Rated secondary current	1 A or 5 A	
Class and nominal overcurrent factor	5 P 10 ext. 120% ❶	
Power rating	According to power consumption in leads and measuring circuits	
Rated frequency	50/60 Hz	
Burden:	825-M + 825-MCM2	825-M + 825-MCM20
Power consumption at max. rated current ❷	0.1 VA/phase	0.4 VA/phase
Continuous thermal current	3 A	24 A
Thermal current, 1 s duration	250 A	600A
Frequency of input current	50/60 Hz	50/60 Hz
General Notes on 825-MCM...		
No-load	An open-circuit secondary is permitted, as the burden is installed in the detection module	

❶ Designation according to IEC 60044 part 2:

5	Total measurement error (percentage): ±5% within range up to rated nominal overcurrent (10X) ±1% at rated nominal primary current
P	For protection purposes
10	Rated nominal overcurrent factor: 10X rated nominal primary current
ext. 120%	Extended rated thermal current: 120% of rated nominal primary current (if I_e motor > 87% of rated nominal transformer current)

With starting current 10 I_e : class 5 P 20

The current transformer error in addition to the basic unit error

❷ 2.5 A with Cat. No. 825-MCM2, 20 A with Cat. No. 825-MCM20

Core Balance Current Transformer

Table 2.H Recommended Data for Core Balance Current Transformer

Nominal ratio $K_n = \frac{\text{minimum detectable earth (ground) fault}}{\text{Pickup current of basic unit earth (ground) fault protection}}$	
Burden: Measuring circuit 825-M...	
Power consumption at max. rated current	0.4 VA
Continuous thermal current	0.5 A
Thermal current, 1 s duration	25 A
Frequency of input current	50/60 Hz

A core balance current transformer, current ratio = 100:1, is available, and might suit most applications. (Max. earth (ground) fault current = 30 A.

Short-Circuit Protection

Choosing a Circuit Breaker or Fuse and Associated Contactor

The branch circuit short-circuit protective device series (circuit breaker or fuse) must assure that the motor can start while interrupting short-circuit currents rapidly enough to prevent damage to the installation. To aid in the latter, the fuse rating should be as low as possible.

The lowest possible fuse rating depends on the starting current of the motor and the tripping time set on the Smart Motor Manager.

The Short-Circuit Coordination of the Starter Must Always be Taken into Account

The contactor receives its tripping signal when the Smart Motor Manager basic unit trips. The basic unit interrupts all current up to the point of intersection with the time/current characteristics of the circuit breaker or fuse.

When starting large motors, the main contacts on the contactor are subjected to high thermal loads. If the motor starting time exceeds a certain limit, the maximum permissible current has to be reduced.

The rating of the fuse or contactor must also allow for the prospective short-circuit current. The Bulletin 825 converter modules are short-circuit proof.

The coordination (grading) diagrams for contactors are available on request.

Response Supply Voltage Failure

If the supply voltage fails, the setting data are retained.

Failure of Supply Voltage > 30 ms

- All energized output relays drop out
- The LED extinguishes
- The timer for “duration of supply failure” starts (maximum 8 h)
- The instantaneous set and statistical data are recorded
- The LCD extinguishes

Recovery of the Supply Voltage

- Initialization routine is started
- The time of occurrence and the duration of the supply failure are entered into memory
- The thermal image is calculated and updated
- All output relays return to the state before the supply failure, except for relay #2 and #3, when control is executed via communication
- LCD and LED activate

Automatic Recognition of Converter Module

The Bulletin 825 regularly checks:

- The link between the basic unit and the converter module
- Verifies that the full load current set on the basic unit is within the range of the converter module
- The supervisory circuits

In the event of a fault, the output relay MR trips and the type of fault is displayed on the LCD.

Table 2.I Converter Module — Related Error Messages

Verify	Sequence	Display
Link between basic unit and converter module	<ul style="list-style-type: none"> • After switching on supply • Supervision while motor is stationary • When running, as soon as the link is interrupted the basic unit will trip and display one or more of the following causes: <ul style="list-style-type: none"> • short circuit, thermal, earth fault (Holmgreen = residual), asymmetry, overcurrent 	825-MCM NOT CON
Verification that FLC on basic unit is within range of converter module	<ul style="list-style-type: none"> • After switching on supply • After each change in setting of rated current 	le OUT OF RANGE
Supervisory circuits	<ul style="list-style-type: none"> • Continuous monitoring (hardware errors, supply, etc.) 	ERROR 825-MCM

Functions

Menu Overview

Actual Values

In “Actual Values” mode, all operating parameters can be selected and read from the LCD.

Table 3.A Actual Values Overview

Display List		Option Card Cat. No.	Page	Display List		Option Card Cat. No.	Page
I MOTOR	A	—	6-6	I earth - H	%I	—	6-7
I MOTOR	%I _e	—	6-5	I earth - C	mA	—	6-7
I 1	%I _e	—	6-6	Tambient	°C	825-MMV	6-7
I 2	%I _e	—	6-6	PT100 #1(...6)	°C	825-MMV	6-7
I 3	%I _e	—	6-6	PROBUS	—	825-MPB	6-7
TRIP IN	s	—	6-6	RIO	—	3600-RIO	6-7
RESET IN	s	—	6-7	MODBUS	—	3600-MBS	6-7
ASYM	%	—	6-7	DevNet	—	825-MDN	6-7

Set Values

The parameters “Main Settings” and “Special Settings” must be programmed for every application. The other parameters (e.g., “High Overload”, “Asymmetry”) have factory-set values, which are correct for most applications.

Table 3.B Set Values Overview

Parameter List	Option Card Cat. No.	Page	Parameter List	Option Card Cat. No.	Page
THERMAL TRIP	—	5-4	THERMAL RESET LEVEL	—	5-10
THERMAL WARNING	—	5-4	COOLING CONSTANT RATIO	—	5-10
ASYMMETRY TRIP	—	5-5	PTC TRIP	825-MST	5-10
ASYMMETRY WARNING	—	5-5	PTC RESET	825-MST	5-10
OVERCURRENT TRIP	—	5-5	CONTROL INPUT #1		5-10
OVERCURRENT WARNING	—	5-5	DELAY AUX REL # 2	825-MST	5-10
EARTH FAULT PROTECTION	—	5-6	SPEED SWITCH		5-11
EARTH FAULT HOLMGREEN TRIP	—	5-6	DISABLE FUNCTION		5-11
EARTH FAULT CORE TRIP	825-MST	5-7	CONTROL INPUT #2		5-12
EARTH FAULT CORE WARNING	825-MST	5-7	DELAY AUX REL #3	825-MST	5-12
SHORT CIRCUIT PROTECTION	825-MST	5-7	NEW FULL LOAD CURRENT		5-12
UNDERLOAD TRIP	—	5-8	PHASE REVERSAL TRIP	825-MLV	5-13
UNDERLOAD WARNING	—	5-8	PHASE LOSS TRIP		5-13
STAR DELTA STARTING	825-MLV	5-8	PT100 PROTECTION	825-MMV	5-13
WARM STARTING	—	5-9	PT100 RESET/WARNING		
START INHIBIT	—	5-11	OUTPUT 4...20 mA	825-MST	5-15
START CONTROL	—	5-9	STATION NUMBER	—	5-16
MAIN RELAY CONNECTION	—	5-10	REL #2-3 VIA COM	—	5-16
ALARM RELAY CONNECTION	—	5-10	CLEAR RECORDED VALUES	—	5-16
THERMAL RESET	—	5-10	FACTORY SETTINGS	—	5-16

ATTENTION



All parameters can be set, including those functions associated with option boards that have not been mounted in the device. However, these warning and trip functions are not operational unless the corresponding option board is installed.

Recorded Values

In “Recorded values” mode, all recorded data can be selected and read from the LCD.

Table 3.C Recorded Values Overview

Display List		Option Card Cat. No.	Page	Display List		Option Card Cat. No.	Page
825-M MAIN TIME	h min.	—	7-2	CAUSE 2PRV TRIP	—	—	7-3
MOTOR RUNNING HR	h min.	—	7-2	CAUSE 3PRV TRIP	—	—	7-3
SINCE LAST START	h min.	—	7-2	CAUSE 4PRV TRIP	—	—	7-3
SINCE 1PRV START	h min.	—	7-2	SINCE EMG START	h min.	—	7-3
SINCE 2PRV START	h min.	—	7-2	SINCE POWER OFF	h min.	—	7-3
SINCE 3PRV START	h min.	—	7-2	DURATION POW OFF	h min.	—	7-3
SINCE 4PRV START	h min.	—	7-2	I BEF LAST TRIP	% I_e	—	7-3
SINCE LAST TRIP	h min.	—	7-2	AS BEF LAST TRIP	%	—	7-3
SINCE 1PRV TRIP	h min.	—	7-3	EF BEF LAST TRIP	mA, % I_e	—	7-3
SINCE 2PRV TRIP	h min.	—	7-3	MAX T BEF LAST TRIP	°C	825-MMV	7-4
SINCE 3PRV TRIP	h min.	—	7-3	TH BEF LAST TRIP	%	—	7-4
SINCE 4PRV TRIP	h min.	—	7-3	NUMBER START	—	—	7-4
CAUSE LAST TRIP	—	—	7-3	NUMBER TRIP (TH, AS, OC, EF, SC, UL, PTC, PR, PL, PT100)	—	—	7-4
CAUSE 1PRV TRIP	—	—	7-3				

Operation

Selecting the Setting/Display Mode

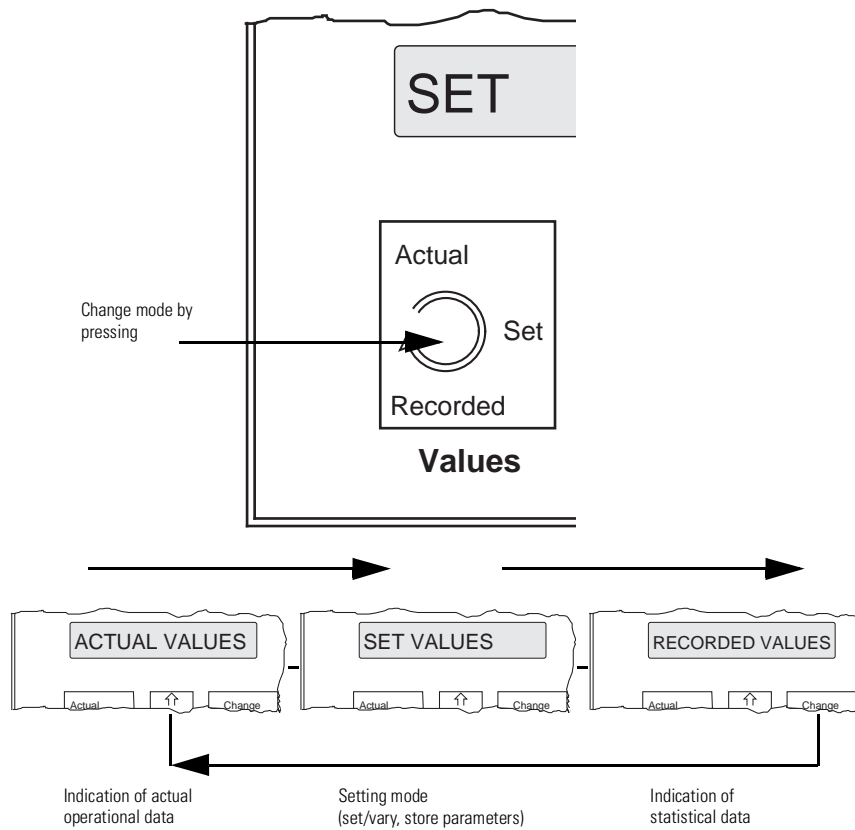

Setting the Operation Parameters (Set Values)

Text and data are indicated alternately (approximately 2 s text and 1 s data). On the “second line,” the data that is factory set or subsequently modified is displayed. Functions not activated (OFF) are not indicated.

1. To set the operation parameters, repeatedly press the *Values* button until “SET VALUES” appears on the display.

Figure 3.1 Setting Mode

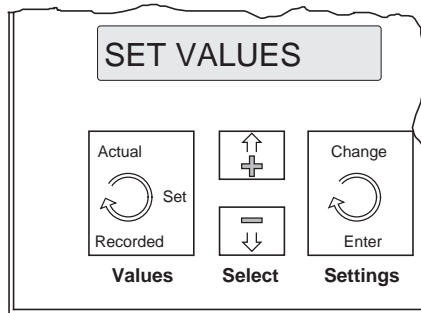

2. Press *Select* (Up or Down) until the desired parameter (e.g., “FULL LOAD CURR” and “35 Amp”) appears (display alternates between text and data).

Figure 3.2 Menu Selection

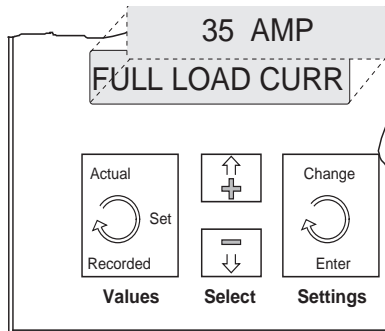

3. Press the *Settings* (Change) button once. The set value begins to flash. A new set value can now be entered by means of the *Select* keys (Up or Down). The entry is completed by pressing *Settings* (Enter).

Figure 3.3 Entering a Data Value

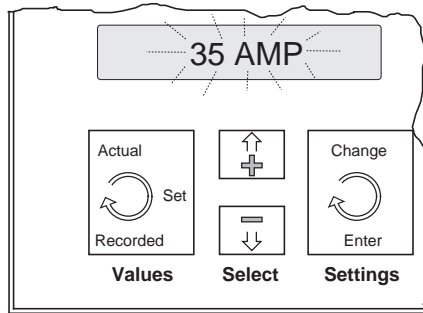

Note: Hold down the *Select* button to change the values more quickly.

Table 3.D Display Example of Set Values Menu

LCD	Range	Description
SET VALUES	—	Mode: setting parameters
FULL LOAD CURR 20 A	0.5...2 000	Rated motor current in A
PRIMARY C.T. NO	No/Yes	Primary current transformer in use
PRIMARY C.T. RATIO 1	1...2 000	Primary current transformer ratio
LOCKED ROT CURR 6 x I _e	2.5...12	Locked rotor current as — I _e
LOCKED ROT TIME 10 sec	1...600	Maximum permitted time for the rotor to be stalled from cold

Note: For a complete list of parameters, refer to [Chapter 5](#).

Indications of Actual Values

In “Actual Values” mode, all operating parameters can be selected and read from the LCD.

1. Press *Values* until “ACTUAL VALUES” appears on the display.
2. Press *Select* (Up or Down) until the desired information is displayed.

Figure 3.4 Selecting the Actual Values

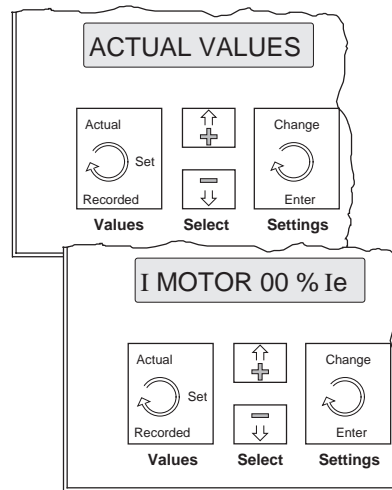

Table 3.E Display Example of Actual Values Menu

LCD	Range	Description
ACTUAL VALUES	—	Display of the actual values
I MOTOR...A	0.00...49.99 50...24 000	Motor current in A
TH UTILIZ...%	0...100	Thermal utilization
I MOTOR...% Ie	0/20...999	Motor current as percent of rated current

Note: For a complete list of parameters, refer to [Chapter 6](#).

Applications

The “Actual Values” mode provides:

- Assistance during programming and setup
- Verification after maintenance or production change
- Continuous operational supervision

Indications of Recorded Values (Statistics)

In “Recorded Values” mode, all recorded data can be selected and read from the LCD.

1. Press *Values* until “RECORDED VALUES” appears on the display.
2. Press *Select* (Up or Down) until the desired statistical information is displayed.

Figure 3.5 Selecting Recorded Data

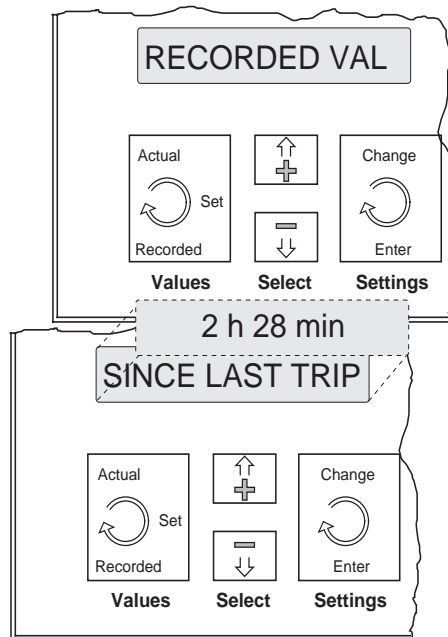

Table 3.F Display Example of Recorded Values

LCD	Description
RECORDED VALUES	Display of the statistical data
825-M MAIN TIME __h__min	Bulletin 825-M* running time (including interruption \leq 8 hour of control voltage in hours, minutes)
MOTOR RUNNING TIME __h__min	Total motor running time in hours, minutes

Note: For a complete list of parameters, refer to [Chapter 7](#).

Applications

The “Recorded Values” mode provides:

- Analysis of motor faults and production interruptions
- Analysis of premature motor failures
- A means of determining maintenance jobs on the switchgear, motor, and installation

Test Button

When the motor is at standstill, the alarms, trips, and tripping times of the protective functions can be checked without external aids by pressing the *Test* button.

Figure 3.6 Basic Unit Test Button

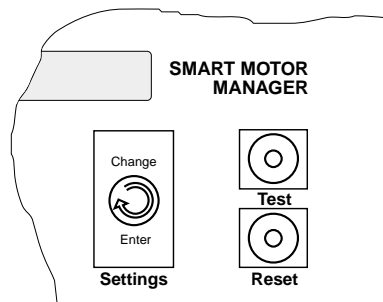

Testing the Thermal Trip

1. Press the *Test* button.

LCD:

TEST THERMAL ON

2. After the set blocking time has expired, the basic unit must trip.

LCD:

LOCK ROT TIME
 _ _ _sec

3. The LED lights.
4. The selected output relay picks up (MR, main relay, on trip).

LCD:

THERMAL TRIP

Resetting

Automatic: The trip becomes inactive when the *Test* button is no longer pressed.

Manual: Reset the trip with the *Reset* button.

Note: After the test, the thermal image resumes its correct state. Simulation of the motor cooling is not affected by the test.

Testing the Trips (Asymmetry/Unbalance, Underload, etc.)

Example: Asymmetry

1. When in “Set Values mode”, access the selected output relay:

LCD:

ASYMMETRY TRIP
 AUX RELAY #2

2. If no output is assigned the following readout appears:

LCD:

ASYMMETRY TRIP
NO OUTPUT RELAY

3. Press the *Test* button.

LCD:

TEST

4. After the set trip delay expires, the basic unit must trip.

LCD:

AS TRIP TIME
__ _sec

5. The LED lights.
6. The selected output relay picks up.

LCD:

ASYMMETRY TRIP

Resetting

Cancel the trip by pressing *Reset*.

Testing the Warning Functions

Example: Asymmetry warning

1. When in “Set Values” mode, access the selected output relay:

LCD:

AS WARNING
ALARM RELAY

2. Press the *Test* button.

LCD:



3. The LED flashes and the selected output relay picks up immediately.

4. LCD flashes

LCD:











Resetting

As soon as the *Test* button is no longer pressed, the unit will automatically reset.

Function Summary

Table 3.G Protective Functions Summary

	Functions Factory Setting	Setting Range	Factory Setting	Tripping Delay Range	Factory Setting	Relays  Selection	Factory Setting
Bulletin 825-M... Basic Unit							
Thermal overload	On		100%	—	—	MR, No	MR
Asymmetry (phase failure)	On	5...80%	35%	1...25 s	2.5 s	All	MR
High overloading/jam	On	1...6 I_e	2.4 I_e	0.1...5 s	0.5 s	All	MR
Underload	Off	25...100%	75%	1...60 s	10 s	All	MR
Underload delayed enable	On	—	—	0...240 s	0 s	—	—
Earth (ground) fault (residual)	On	10...100%	50%	0.1...5 s	0.5 s	All	MR
Starting time monitor	Off	—	—	1...240 s	10 s	All	MR
Limited starts per hour	Off	1...10	2	—	—	All	MR
Bulletin 825-MST Option Card							
Short-circuit	Off	4...12 I_e	10 I_e	20...990 ms	50 ms	#1, No	#1
Earth (ground) fault (core balance c.t.)	Off	5 mA...50 A	1 A	0.1...5 s	0.5 s	All	MR
Stalling during start	Off	—			—	All 	MR 
Thermistor input (PTC)	Off	—	—	—	800 ms	All	MR
Bulletin 825-MLV Option Card							
Phase sequence (motor supply)	Off	—	—	—	1 s	All	MR
Phase failure (motor supply)	Off	—	—	—	2 s	All	MR
Bulletin 825-MMV Option Card							
PT100 input #1...#6 (RTD) (stator, bearings)	Off	50...200 °C	50 °C	—	< 8 s	MR, AL #1...#3	MR
PT100 input #7 (RTD) 	Off	—	—	—	—	—	—

-  Via external speedometer (control input #1), output and trip relays as for high overload.
-  Allowing for the ambient temperature in the thermal image.
-  Only one relay per function can be selected: MR = main relay, AL = alarm relay, auxiliary relay #1...#5 (if auxiliary relays #2 and #3 are assigned to the communication [refer to page 5-16] they cannot be selected here).

ATTENTION



Warning function settings must be such that associated alarms are actuated before a trip occurs.

Table 3.H Warning Functions Summary

	Functions Factory Setting	Setting Range	Factory Setting	Tripping Delay Range	Factory Setting	Relays ❶ Selection	Factory Setting
Bulletin 825-M... Basic Unit							
Thermal utilization (% $\Delta\vartheta$ load)	Off	50...99%	75%	—	—	AL, #1...5	AL
Asymmetry (% I_e)	Off	5...80%	20%	—	—	AL, #1...5	AL
High overloading ($x I_e$)	Off	1...6 I_e	2 I_e	—	—	AL, #1...5	AL
Underload	Off	25...100%❷	75%❷	—	—	AL, #1...5	AL
Bulletin 825-MST Option Card							
Earth (ground) fault (core balance c.t.)	Off	5 mA...50 A	500 mA	—	—	AL, #1...5	AL
Bulletin 825-MMV Option Card							
PT100 input #1...#6 (RTD) (stator, bearings)	Off	50...200 °C	50 °C	—	—	AL, #1...3	AL

- ❶ Only one relay per function can be selected: MR = main relay, AL = alarm relay, auxiliary relay #1...#5 (if auxiliary relays #2 and #3 are assigned to the communication [refer to page 5-16] they cannot be selected here).
- ❷ Same setting as for the Underload Trip function.

Table 3.I Control Functions Summary

	Functions Factory Setting	Setting Range	Factory Setting	Tripping Delay Range	Factory Setting	Relays Selection	Factory Setting
Bulletin 825-M... Basic Unit							
Warm start (% of "cold" trip)	Off	50...100%	70%	4...60 min. ②	60 min. ②	—	—
Emergency override of thermal trip ①	—	—	—	—	—	—	—
Bulletin 825-MST Option Card							
Analog output assigned to: thermal utilization PT100 max. temperature I Motor	On	4...20 mA 0...100% 50...200 °C 0...200% I _e	—	—	—	—	—
Bulletin 825-MST Option Card, Control Input #1: (24V AC/DC; 8 mA)							
One of 3 functions can be selected:							
1) Pickup delay, relay #2	Off	—	—	0...240 s	1 s	—	#2
1) Dropout delay, relay #2	—	—	—	0...240 s	2 s	—	#2
2) Speed switch	Off	—	—	—	—	—	high over-load relay
3) Disable protective functions:							
Asymmetry/phase failure	Off	—	—	—	—	—	—
High overload/jam	Off	—	—	—	—	—	—
Earth (ground) fault	Off	—	—	—	—	—	—
Short-circuit	Off	—	—	—	—	—	—
Underload	Off	—	—	—	—	—	—
Limiting starts/hour	Off	—	—	—	—	—	—
PTC	Off	—	—	—	—	—	—
PT100 (RTD)	Off	—	—	—	—	—	—

- ① Terminals Y11...Y12 must be jumpered.
- ② Minimum waiting time between two warm starts.

Table 3.1 Control Functions Summary (Continued)

	Functions Factory Setting	Setting Range	Factory Setting	Tripping Delay Range	Factory Setting	Relays Selection	Factory Setting
Bulletin 825-MST Option Card, Control Input #2: (24V AC/DC; 8 mA)							
One of three functions can be selected:							
1) Pickup delay, relay #3	Off	—	—	0...240 s	1 s	—	#3
1) Dropout delay, relay #3	—	—	—	0...240 s	2 s	—	#3
2) Set second rated current ❶	Off	0.5... 2 000 A	20 A	—	—	—	—
3) Disable protective functions:							
Asymmetry/phase failure	Off	—	—	—	—	—	—
High overload/jam	Off	—	—	—	—	—	—
Earth (ground) fault	Off	—	—	—	—	—	—
Short-circuit	Off	—	—	—	—	—	—
Underload	Off	—	—	—	—	—	—
Limiting starts/hour	Off	—	—	—	—	—	—
PTC	Off	—	—	—	—	—	—
PT100 (RTD)	Off	—	—	—	—	—	—
Bulletin 825-MLV Option Card							
Star-delta starting	Off	—	Y-Δ at 1.1 I_e	Y-Δ at 1...240 s	10 s	—	Y: #4/Δ:#5

❶ For example, when used with two-speed motors

Functions of the Basic Unit (Cat. No. 825-M...)

Thermal Overload

The Smart Motor Manager accurately simulates thermal conditions in the motor for all operating modes. This permits maximum utilization of an installation and assures safe protection of the motor.

The basic unit uses a two-body simulation to calculate a more precise representation of a motor's thermal condition during all modes of operation. A two-body simulation incorporates the temperature rise characteristics of both the stator windings and the iron mass of the motor into the thermal image.

The simulation of the Smart Motor Manager accurately represents the conditions in the motor at all times.

While the motor is running, the iron losses as well as losses caused by asymmetry are fed to the simulation model. Allowance for the ambient temperature of the motor, as an option, enhances the maximum utilization of the installation even with considerable variation of the temperature. Without the optional inclusion of the ambient temperature of the motor, the thermal model bases the thermal calculation on an ambient temperature of 40° C. The different cooling conditions of a self-ventilated motor when running and at standstill are taken into account by two different time constants. After switching off, the rapid cooling of the winding to the iron temperature and the subsequent slow cooling of the motor as a whole are simulated.

The two-body simulation can be represented as a capacitance-resistance network. See Figure 3.7.

Figure 3.7 Two-Body Simulation of the Heating Up of a Motor

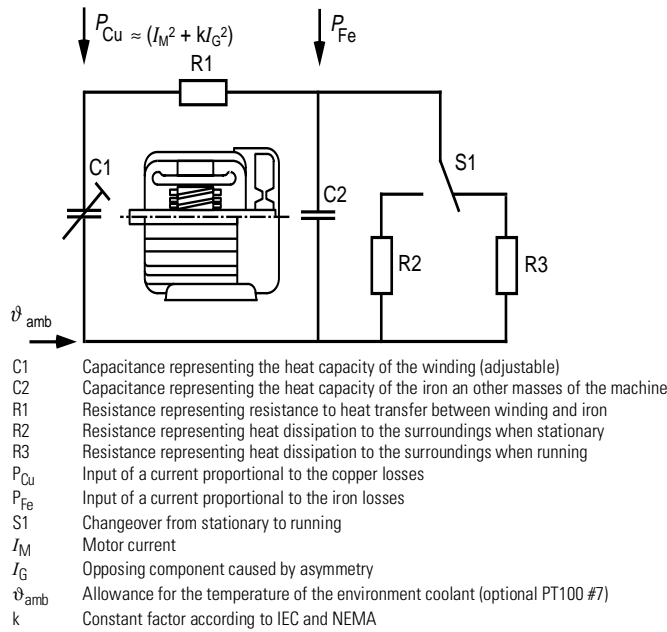

Adjustable Ratio of Cooling Constants

The ratio of the cooling constant when the motor is at standstill to the cooling constant when it is running allows for the difference in cooling in these states. The cooling constant ratio is set to 2.5 in the factory. This value is correct for the majority of self-cooled AC motors.

For separately ventilated and special motors, and those which respond very quickly or very slowly, you may have to modify the cooling factor.

Indication of the Time to Tripping

LCD:

A rounded rectangular box representing an LCD display with the text "TRIP IN...sec" inside.

This feature provides continuous indication of the time remaining before tripping when in an overload condition. This enables you to intervene before tripping occurs. (Blank display means: Time > 9 999 s)

Indication of the Time until the Thermal Trip can be Reset

LCD:

A rounded rectangular box representing an LCD display with the text "RESET IN ...sec" inside.

Following a thermal trip, the basic unit may not be reset until the reset threshold has been reached. This is set to a temperature rise of 50% in the factory.

Adjustable Setting Characteristic

The degree of inertia can be set to match the properties of the motor. A suitable reference value, among others, is the admissible locked-rotor time of the cold motor in conjunction with the associated current. This makes it possible to protect motors that are thermally very fast or very slow. See Figure 3.8, Figure 3.9, and Figure 9.15.

The thermal capacity of the iron is particularly important at small overloads. Allowing for this in the simulation enables the overload reserves of the motor to be utilized without risking a premature protective trip.

Figure 3.8 Trip Characteristic (10...30 s)

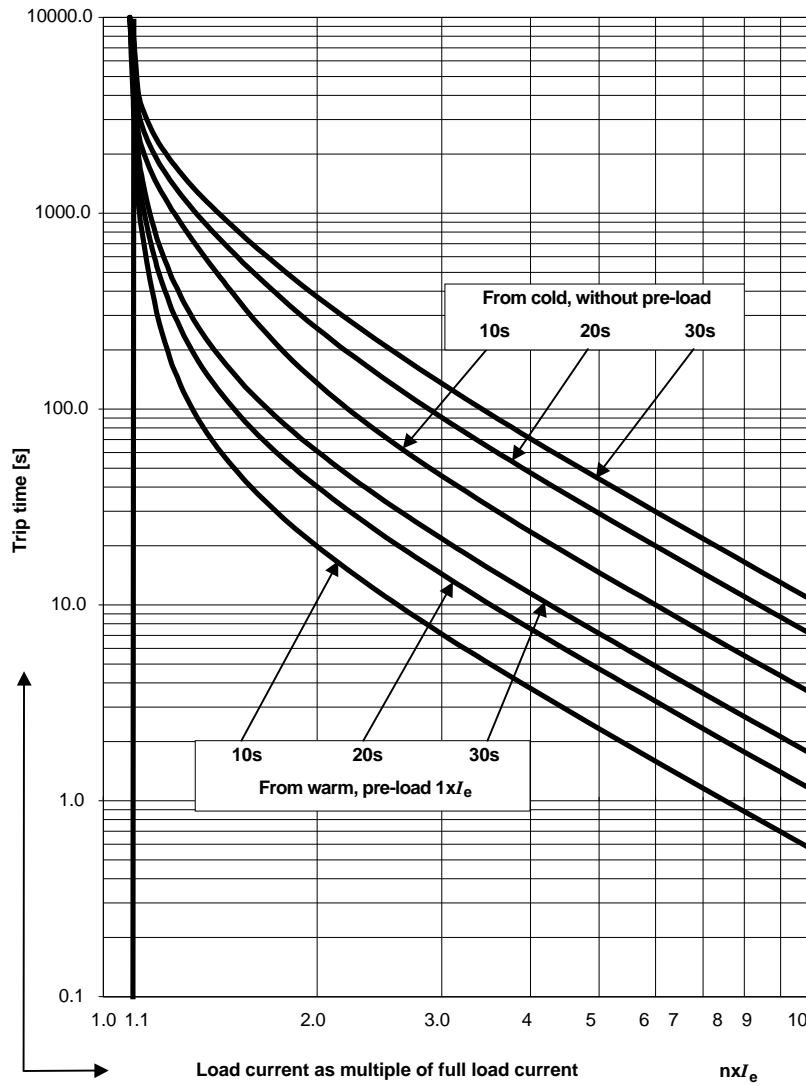
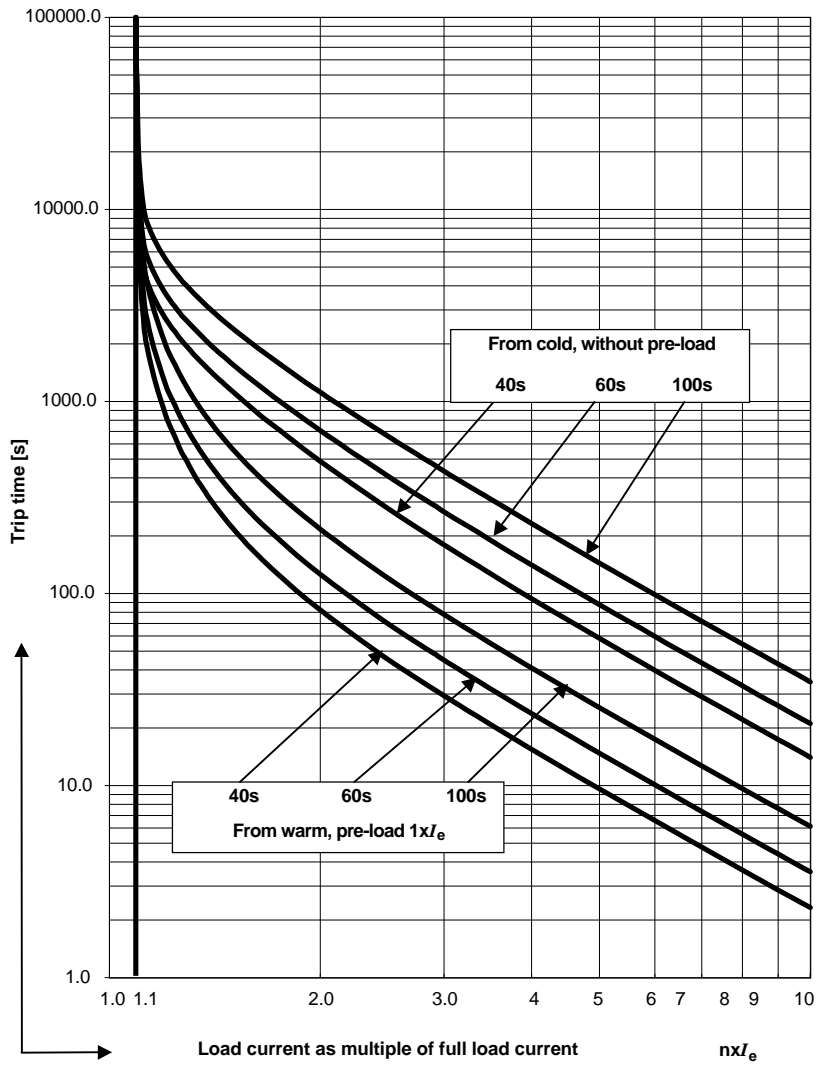

Figure 3.9 Trip Characteristics (40...100 s)



For UL/CSA applications refer to page 9-14.

Table 3.J Thermal Overload Setting Parameters

	Detection Module ②				
	825-MCM2	825-MCM20	825-MCM180	825-MCM630	825-MCM630N
Rated Current					
Setting range	0.5...2.5 A ①	2.5...20 A ①	20...180 A	160...630 A ③	160...630 A
Factory setting	20 A	20 A	20 A	20 A	20 A
Setting increments	0.01...2 A	0.1...2 A	1 A	2 A	2 A
Locked-Rotor Current (Multiple of Rated Current)					
Setting range	2.5...12 I_e				
Factory setting	6 I_e				
Setting increments	0.1 I_e				
Locked-Rotor Time (Admissible Locked-Rotor Time of Cold Motor)					
Setting range	1...600 s				
Factory setting	10 s				
Setting increments	1 s				
Cooling Factor of Motor Off/On ④					
Setting range	1...10				
Factory setting	2.5				
Setting increments	0.5				
Resetting the Thermal Trip					
Setting range	10...100% of thermal utilization				
Factory setting	50%				
Setting increments	1%				
Ultimate Release Current					
Incl. setting tolerance	1.05...1.15 I_e				

① Up to 2 000 A, if primary current transformers are used.

② -5...60 °C (23...140 °F)

③ UL/CSA 160...434 A

④ The cooling factor can be modified to reflect different motor cooling with running motor and at standstill.

Table 3.K Protection Against Thermal Overload

	Warning	Trip
Function		
Factory setting	Off	On
Response Level ❶		
Setting range	55...99%	—
Factory setting	75%	100%
Setting increments	1%	—
Output Relay ❷		
Selection	AL, #1...#5	MR, No output relay
Factory setting	AL	MR

- ❶ Thermal utilization %
- ❷ If auxiliary relays #2 and #3 are assigned to the communication (refer to page 5-16) they cannot be selected here.

Asymmetry (Phase Unbalance) and Phase Failure

Asymmetrical phase voltages usually occur when the leads closest to the motor are too long. The resulting current asymmetry in the motor windings may then be 6...10 times the voltage asymmetry. The Smart Motor Manager takes into account the additional temperature rise and thus prevents the life of the motor from being reduced. Higher asymmetry or the failure of a phase can be caused by defective contacts in circuit breakers or contactors, loose terminals, blown fuses, and faults in the motor itself. Rapid detection and interruption of these factors help to prevent damage caused by overheating in such equipment. The stress on the installation and the motor bearings is reduced. The Smart Motor Manager measures the phase currents and calculates the total copper losses according to the definition of voltage asymmetry per IEC and NEMA.

$$P_{Cu} \approx (I^2_M + kI^2_G)$$

Definition of voltage asymmetry per IEC and NEMA:

$$\Delta U(\%) = \frac{\text{Max. deviation from the average of the phase voltages} \times 100}{\text{Average of the phase voltages}}$$

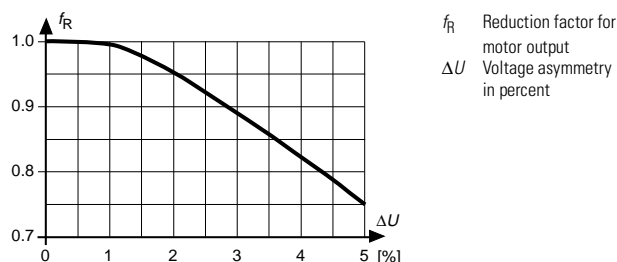
Figure 3.10 Reduction in Permissible Motor Output Due to Voltage Asymmetry per IEC and NEMA**Table 3.L Asymmetry (Phase Unbalance) Setting Parameters**

	Warning ① (Current Asymmetry)	Trip ①
Function		
Factory setting	Off	On
Response Level		
Setting range	5...80%	5...80%
Factory setting	20%	35%
Setting increments	5%	5%
Tripping Delay		
Setting range	—	1...25 s ± 0.2 s
Factory setting	—	2.5 s ± 0.2 s
Setting increments	—	0.5 s
Output Relay ②		
Selection (relays)	AL, #1...#5	MR, AL, #1...#5
Factory setting	AL	MR

① -5...60 °C (2...140 °F)

② If auxiliary relays #2 and #3 are assigned to the communication (refer to page 5-16) they cannot be selected here.

High Overload and Jam

When an overload is excessively high and the motor jams, unnecessary mechanical and thermal loading of the motor and transmission elements can be avoided by switching the motor off immediately. This reduces consequences of accident and loss of production. A gradual increase in overload can be detected early and reported (e.g., bearing damage). The protective function activates as soon as the motor has started.

Application

- Conveying systems
- Mills
- Mixers
- Crushers
- Saws, etc.

Figure 3.11 Function of High Overload and Jam Protection

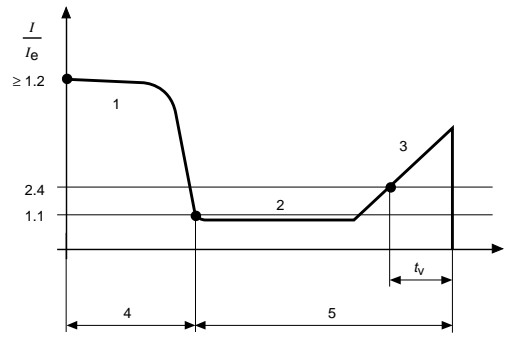

- | | | | |
|---|------------------------------|-------|--|
| 1 | Motor start $I \geq 1.2 I_e$ | t_V | Tripping delay |
| 2 | Nominal operation | 4 | Jam protection not active |
| 3 | High overload or jam | 5 | Jam protection active (tripping threshold) |

Table 3.M High Overload and Jam Setting Parameters

	Warning ❶	Trip ❶
Function		
Factory setting	Off	On
Response Level		
Setting range	1...6 I_e	1...6 I_e
Factory setting	2 I_e	2.4 I_e
Setting increments	0.2 I_e	0.2 I_e
Tripping Delay		
Setting range	—	0.1...5 s \pm 0.04 s
Factory setting	—	0.5 s \pm 0.04 s
Setting increments	—	0.1 s
Output Relay ❷		
Selection (relays)	AL, #1...#5	MR, AL, #1...#5
Factory setting	AL	MR

- ❶ -5...60 °C (23...140 °F)
 ❷ If auxiliary relays #2 and #3 are assigned to the communication (refer to page 5-16) they cannot be selected here.

ATTENTION

It is essential to set the “Warning” response level to a value less than the “Trip” response level.



Note: If the starting current is below 1.2 FLC, then the “Monitoring the Start Time” function must be activated. After the set max. starting Time has elapsed, the “High Overload/Stall” function will become active.

Applications:

- Slip ring motors
- Soft starters
- Motor protection with “non-fail-safe mode”, after a control voltage failure

Underload

Motors that are cooled by the medium handled (e.g., fans, submersible pumps) can become overheated despite being underloaded. This can be a result of the absence of the medium or insufficient medium (due to clogged filters, closed valves, etc.). Often these motors are installed in inaccessible places, so repair is lengthy and expensive.

The consumption of less than a preset, application-specific amount of current may indicate a mechanical defect in the installation (e.g., torn conveyor belt, damaged fan blades, broken shafts or worn tools). Such conditions do not harm the motor, but they do lead to loss of production. Rapid fault detection helps to minimize damage.

The underload protection trip time can be delayed following each start to prevent tripping. The warning is actuated as soon as the underload threshold is reached.

Application

- Submersible pumps
- Fans
- Conveyor systems
- Detection of fractures in mechanical transmission system

Figure 3.12 Function of Underload Protection

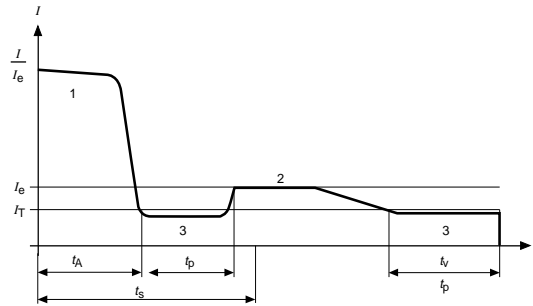

- 1 Start
- 2 Nominal operation
- 3 Underload operation
- t_A Starting time
- I_e Rated current

- I_r Tripping threshold
- t_s Delayed activation (underload protection not active)
- t_v Tripping delay
- t_p Warning

Table 3.N Underload Setting Parameters

	Warning ❶	Trip ❶
Function		
Factory setting	Off	On
Response Level		
Setting range	❷	25...100% I_e
Factory setting	❷	75%
Setting increments	❷	5%
Tripping Delay		
Setting range	—	1...60 s -0.2 s/+0.4 s
Factory setting	—	10 s
Setting increments	—	1 s
Delayed Activation of Underload Protection		
Setting range	—	0...240 s +0.4 s/+0.8 s
Factory setting	—	0 s
Setting increments	—	1 s
Output Relay ❸		
Selection (relays)	AL, #1...#5	MR, AL, #1...#5
Factory setting	AL	MR

- ❶ -5...60 °C (23...140 °F)
- ❷ For warning, the set Response Level is the same as the level set for tripping. If the starting current is below 1.2 FLC, then the "Monitoring the Start Time" function must be activated. After the set max. starting Time has elapsed, the "High Overload/Stall" function will become active.
- ❸ If auxiliary relays #2 and #3 are assigned to the communication (refer to page 5-16) they cannot be selected here.

Earth (Ground) Fault

The insulation in motors is often damaged by high-voltage surges, which may be caused by lightning strikes, switching operations in the network, capacitor discharges and power electronics equipment. Other causes are aging and sustained or cyclic overloading, as well as mechanical vibration and the entry of foreign objects. Most insulation faults result in leakage to the grounded parts of the machine. In earthed (grounded) networks, the fault current can rapidly rise to a very high value. Depending on the type of network and its requirements, monitoring of earth (ground) faults is performed either by the residual method or by using a core balance current transformer.

Earth (Ground) Fault Protection by the Holmgreen Method = Residual Method (Solidly Earthed Networks)

To detect an earth (ground) fault current in either a solidly earthed (grounded) network or one that is earthed through a low impedance, the currents in each of the three pole conductors are measured. In a “healthy” motor, this sum is zero. If a current is flowing to the frame of the motor, and thus to earth, a neutral current I_0 , proportional to the fault current, is produced at the neutral of the current transformer. This neutral current is detected by the earth (ground) fault detector and causes a trip. A brief delay helps to avoid nuisance trips caused by transient current transformer saturation, which can be caused by switching operations. The sensitivity has to be such that neither transformation errors in the current transformer nor disturbance signals in star-delta (wye-delta) connections caused by the third harmonic cause nuisance tripping.

Figure 3.13 3-Phase Current Detection

Measurement of the neutral current I_0 in the neutral connection of the current transformer to detect an earth (ground) fault (residual circuit)

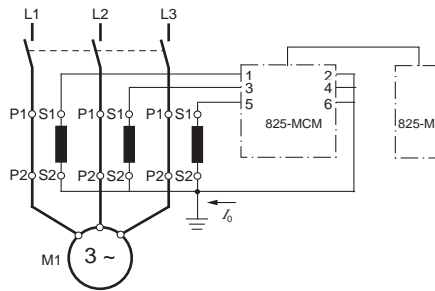

Table 3.0 Earth (Ground) Fault — Holmgreen/Residual Setting Parameters

Function	Trip ❶
Factory setting	On
Response Level	
Setting range	10...100%
Factory setting	50%
Setting increments	10%
Tripping Delay	
Setting range	0.1...5 s ± 0.4 s
Factory setting	0.5 s
Setting increments	0.1 s
Output Relay ❷	
Selection (relays)	MR, AL, #1...#5
Factory setting	MR

- ❶ -5...60 °C (23...140 °F)
- ❷ If auxiliary relays #2 and #3 are assigned to the communication (refer to page 5-16) they cannot be selected here.

Earth (Ground) Fault Protection with a Core Balance Current Transformer

This function can be provided by the Cat. No. 825-MST option card.

In isolated, high impedance-earthed or compensated networks, the necessary high sensitivity is obtained by using a core balance current transformer, whose core surrounds all three of the phase leads to the motor.

According to the principle of the residual current protection circuit breaker, sensitive protection against earth (ground) faults is possible. With a low response threshold, quite a minor insulation fault can lead to a warning or trip at an early stage.

Figure 3.14 Example of 2-Phase Current Sensing

Example of 2-phase current detection and core balance current transformer for sensitive earth (ground) fault protection (3-phase current detection is also possible)

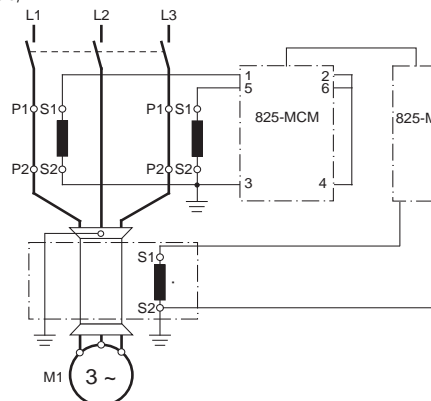

Application

- High-voltage motors
- Installations in a difficult environment, with moisture, dust, etc. (e.g., mines, gravel pits, cement factory, mills, woodworking shops, water pumping stations, waste water treatment)

Table 3.P Core Balance Current Transformer Setting Parameters

Current Ratio	
Setting range	1...2 000
Factory setting	100
Setting steps	1

Table 3.Q Earth (Ground) Fault Core Balance Setting Parameters

	Warning ❶	Trip ❶
Function		
Factory setting	Off	On
Response Level		
Setting range	5 mA...50 A	5 mA...50 A
Factory setting	500 mA	1.0 mA
Setting increments	5 mA	0.25 A
Tripping Delay		
Setting range	—	0.1...5 s ± 0.04 s
Factory setting	—	0.5 s
Setting increments	—	0.1 s
Output Relay ❷		
Selection (relays)	AL, #1...#5	MR, AL, #1...#5
Factory setting	AL	MR

❶ -5...60 °C (23...140 °F)

❷ If auxiliary relays #2 and #3 are assigned to the communication (refer to page 5-16) they cannot be selected here.

Earth (Ground) Fault Protection in High-Voltage Systems

This section provides an overview of earth (ground) faults in isolated, high-impedance earth, or compensated networks.

With earth neutral point-type networks, the magnitude of the earth (ground) fault (leak) current is determined by the earth capacitance of the network and the earth resistance or the compensating reactor. Because the size of industrial networks is limited, earth fault currents are very small. To a great extent, earth capacitances are determined by the cables and the motors.

The capacitance values for cables are given in cable tables and range from approximately 0.2...1.2 µF/km. A value between 0.02...0.05 µF per MW of motor rating can be assumed for high-voltage motors.

A rule of thumb for industrial medium voltage networks is to allow about 1 A of capacitive earth current for every 1 000...1 500 kVA of system power. Usually, the displacement voltage is measured at a single neutral point and is assumed to be representative of the entire network.

The earth (ground) fault is localized by using an earth (ground) fault current detector, such as the Smart Motor Manager with earth (ground) fault protection, in the motor feeders. Often, operation can continue since the earth currents are comparatively insignificant and the insulation of the non-faulty phases can be operated at a higher voltage for a short period of time.

Isolated or High-Impedance Earth Networks

In the case of earth capacitances, the neutral point of the network assumes earth potential and the sum of the currents flowing through the earth capacitances is zero. Also, no current flows in normal operation in the high-value earth resistor (Figure 3.16, Figure 3.18, and Figure 3.20) in the case of transformer with neutral point. It avoids extreme overvoltages in the event of intermittent earth faults, such as can occur in isolated networks.

If, for example, phase conductor 3 (Figure 3.15 and Figure 3.17) becomes connected to earth due to an earth fault, the two other phase conductors carry a line-to-line voltage with respect to earth. Through their earth capacitances, C_N (on the power supply side as seen from the Smart Motor Manager) and C_M (on motor side), a capacitive current flows toward earth and back to phase conductor 3 through the fault location. In the case of high-impedance earthing (Figure 3.16, Figure 3.18, and Figure 3.20), the neutral point voltage, now at a high value, causes an additional current that is limited by the earthing resistor through the fault location.

In the event of an earth fault on the power supply side of the measuring location (current transformer installation location), the basic unit measures the component of the earth current flowing via C_M . The response sensitivity must be selected such that in this case, the Smart Motor Manager does not trip. On the other hand, earth fault detection by the Smart Motor Manager should be as sensitive as possible since, in the case of earth faults in the motor windings, the displacement voltage becomes smaller the closer the fault location is to the neutral point. The fault current decreases proportionally. Normally, a response threshold is selected that is greater than 5...10% of the current that flows in the event of a dead earth fault at the motor terminals.

Neutralized Networks

Systems with earth fault neutralizers, resonant-earth system, Petersen coil. Although compensated industrial networks are rare, their main features are shown in Figure 3.16, Figure 3.18, and Figure 3.20. Under fully compensated conditions, the compensation reactor supplies a current of the same magnitude as that of the capacitive fault current but phase shifted by 180° so that only a small ohmic residual current flows via the fault location.

Schematic Representation of Various Network Configurations and Earth (Ground) Fault Locations

The earth (ground) fault current measured by the Smart Motor Manager with the aid of a core balance current transformer is dependent on the power supply network configuration and on the location of the earth fault. The following diagrams indicate the relationships in the various applications.

The symbols used have the following meanings:

- C_N Earth capacitance of phase conductor on power supply system side
- C_M Earth capacitance of motor including supply conductors between current transformer and motor
- L Compensating coil
- R High earthing resistance
- T Transformer
- I_E Earth (ground) fault current

Figure 3.15 Isolated Network: Earth Fault on the Network Side

The basic unit measures the earth current component through C_M .

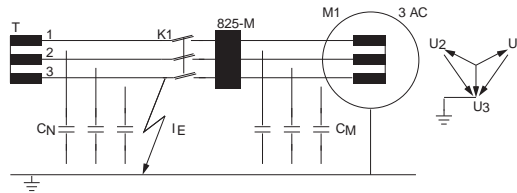

Figure 3.16 Network Earthed through a High Impedance: Earth Fault on the Network Side

The basic unit measures the earth current component through C_M . Compensated network: Through the fault a small current flows, given by the vector sum of the earth currents.

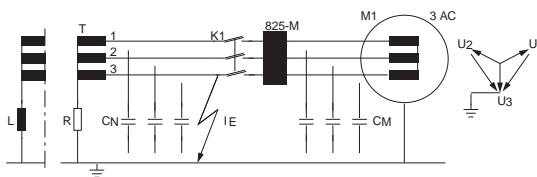

Figure 3.17 Isolated network: Earth (Ground) Fault on the Leads on the Motor Side

The basic unit measures the earth current component through C_M .

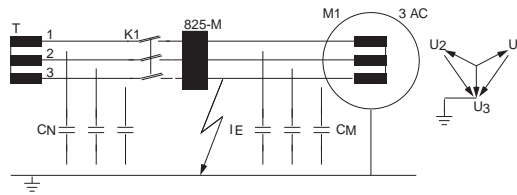

Figure 3.18 Network Earthed through a High Impedance: Earth (Ground) Fault on the Motor Leads

The basic unit measures the vector sum of the earth currents through C_N and the earthing resistance R.

Compensated network: The basic unit measures the vector sum of the earth currents through C_N and the compensating coil L.

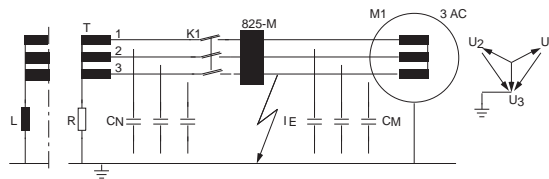

Figure 3.19 Isolated Network: Earth (Ground) Fault in the Motor

The nearer the fault is to the motor star-point, the smaller the fault current.

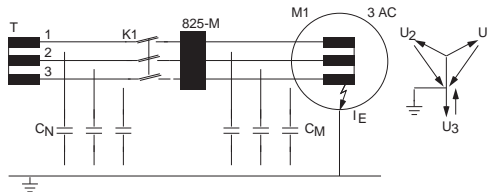
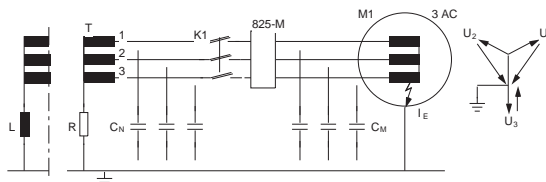

Figure 3.20 Network Earthed through a High Impedance: Earth (Ground) Fault on the Motor

The basic unit measures vector sum of the earth currents through C_N and the earthing resistance R.

Compensated network: The basic unit measures the vector sum of the earth currents through C_N and the compensating coil L.

The nearer the fault is to the motor star-point, the smaller the fault current.



Limiting the Number of Starts per Hour (Start Lockout)

Function

When the set number of starts is reached and the motor is switched off, a new start is prevented. Depending on its setting, either the main relay changes to “Fault”, or the selected auxiliary is activated.

As soon as a new start is permissible, the start lockout is automatically reset.

Figure 3.21 Limiting the Number of Starts per Hour

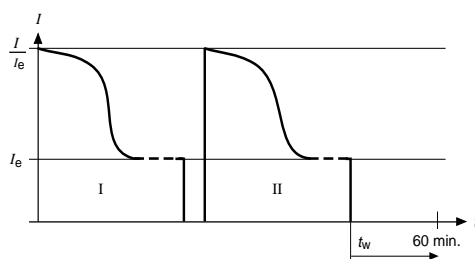

- I* First start
- II* Second start
- t_w The selected relay (MR, or #1...#5) remains in the tripped position until 60 min. have expired. If an additional start is allowed, the number of starts can be increased by one.

Table 3.R Starts per Hour Setting Parameters

Function	
Factory setting	Off
Setting	
Setting range	1...10 starts/hour
Factory setting	2 starts/hour
Setting increments	1
Output Relay ①	
Selection (relays)	MR, AL, #1...#5
Factory setting	MR

- ① If auxiliary relays #2 and #3 are assigned to the communication (refer to page 5-16) they cannot be selected here.

ATTENTION



The motor manufacturer's instructions regarding the permissible number of starts per hour and the minimum waiting time between individual starts must be complied with.

Note: The thermal protection of the motor is independent of this function. Each start depends on the thermal reserve of the motor.

Monitoring the Starting Time

Function

The starting time of the motor is monitored. If starting has not finished by the set time, the installation can be switched off. This monitoring is independent of the thermal state of the motor.

The beginning of a start is recognized by the Smart Motor Manager when the motor current reaches $1.2 I_e$. Starting is deemed to have been completed when the motor current is less than $1.1 I_e$.

Applications

- Installations in which an elevated load or stalling of the drive have to be detected during the starting stage, in order to avoid serious damage. Possible causes: overloaded installation, defective bearings, or transmission elements.

Figure 3.22 Monitoring Starting Time

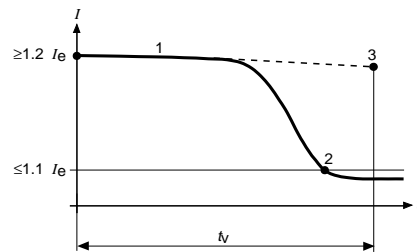

- | | |
|-------|---------------------------------------|
| 1 | Motor starting current $\geq 1.2 I_e$ |
| 2 | Rated conditions |
| t_y | Max. starting time |
| 3 | Tripping if starting lasts too long |

Table 3.S Monitoring Start Time Setting Parameters

Function	
Factory setting	Off
Max. Starting Time ❶	
Setting range	1...240 s ± 0.04 s
Factory setting	10 s ± 0.04 s
Setting increments	1 s
Output Relay ❷	
Selection (relays)	MR, AL, #1...#5
Factory setting	MR

❶ -5...60 °C (23...140 °F)

❷ If auxiliary relays #2 and #3 are assigned to the communication (refer to page 5-16) they cannot be selected here.

Note: With Star-Delta (Wye-Delta) starting, the total starting time (Star and Delta) is monitored. If immediate switch off is demanded in the event of stalling, monitoring must be provided by a zero speed switch (function “stalling during starting”).

Note: If the starting current is below 1.2 FLC, then the “Monitoring the Start Time” function must be activated. After the set max. starting Time has elapsed, the “High Overload/Stall” function will become active.

Applications:

- Slip ring motors
- Soft starters
- Motor protection with “non-fail-safe mode”, after a control voltage failure

Warm Start

Function

The motor windings may be heated for a short time above the permissible temperature limit. This applies particularly to rotor-critical motors. The temperature that is permitted for this short period is approximately 250 °C and is thus appreciably higher than the continuous operating temperature of 100...150 °C. This means that a motor warm from running has a relatively long permissible starting time. This property of the motor can be used with the Smart Motor Manager, which is factory-set for one warm start per hour. The tripping time is then 70% of that from cold. The warm start function is switched off in the factory. As additional protection for the motor, too many warm starts can be prevented by the “limiting the number of starts per hour” function.

Figure 3.23 Current and Temperature Curves for Warm and Cold Motor Starts and the Smart Motor Manager Tripping Limits

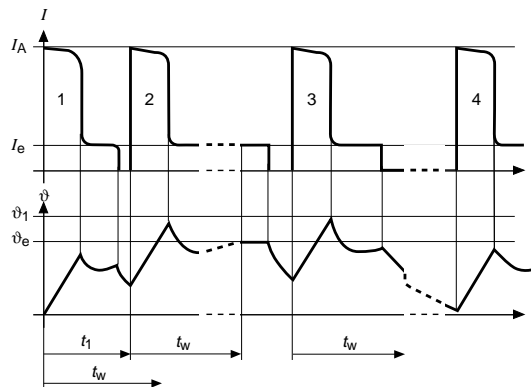

I_A	Starting current	1	First start (cool)
I_e	Rated current	2	First warm start
ϑ_e	Permissible temperature of the motor in continuous operation and normal tripping limit of 825-M for continuous operation	3	Second warm start
		4	Cold start (after the motor has cooled down)
		t_1	Minimum time before first start is possible ($t_1 > 10t_{\vartheta/e}$)
ϑ_1	Motor temperature permissible for a short time and tripping limit of 825-M with modified characteristic for warm start	t_w	Minimum waiting time warm starts (4...60 min.)

ATTENTION



The motor manufacturer's instructions must be complied with, especially regarding the minimum wait between two starts

An attempt to start may be made before the time has elapsed. The Smart Motor Manager will trip during starting if the thermal capacity available is not sufficient.

Applications

- The Warm Start function can be used in any installation that may have to be re-started immediately after a voltage interruption.
- Chemical process and production plants (e.g., mixers, centrifuges, pumps, conveyor systems)
- Mines and tunnels (fresh air fans, water pumps)

Figure 3.24 Example for $t6xI_e = 10$ s and Warm Trip Time = 70%

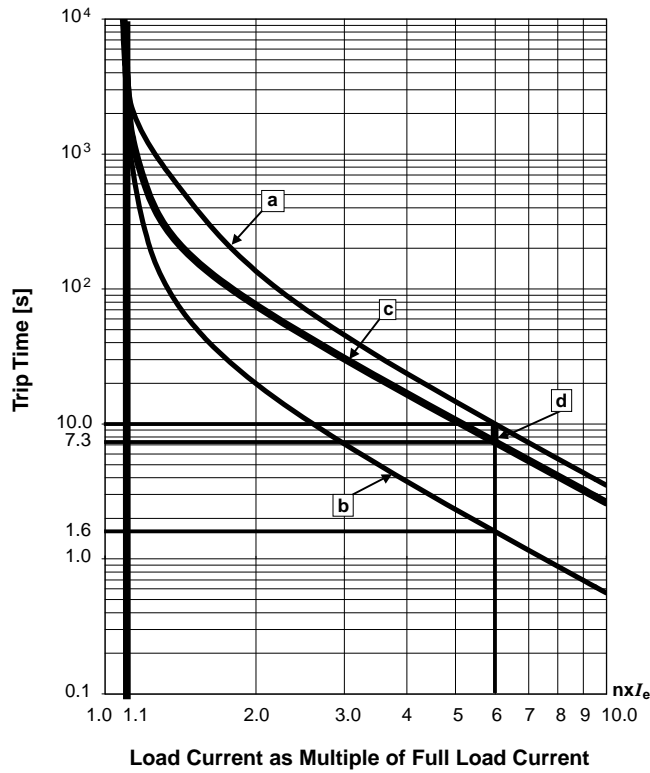

- a) Time/current characteristic from cold when setting the trip time $t6xI_e = 10$ s.
- b) Time/current characteristic after preloading with $1xI_e$ when the trip time from cold $t6xI_e = 10$ s and WARM START function is disabled.
- c) Time/current characteristic after preloading with $1xI_e$ (thermal utilization or winding temperature = 82%) when the trip time from cold $t6xI_e = 10$ s and WARM START function is enabled, setting: WARM TRIP TIME = 70% of the trip time from cold. (The WARM TRIP TIME 7.3 s for $6xI_e$ is higher than $(70\% \times 10) = 7$ s because it depends on the winding and iron temperature which are not at their highest value.)
- d) If the thermal utilization (winding temperature) is higher than 82%, the WARM START function is automatically disabled. If lower than 82% the WARM TRIP TIME depends on the winding and iron temperature and its range is 7.3...10 s.

Table 3.T Warm Start Setting Parameters

Function	
Factory setting	Off
Tripping Time from Warm State as a Percentage of Tripping Time from Cold State	
Setting	
Setting range	50...100%
Factory setting	70%
Setting steps	10%
Minimum Time Between Two Warm Starts	
Setting	
Setting range	4...60 min.
Factory setting	60 min.
Setting steps	1 min.

Emergency Override of Thermal Trip (Emergency Start)

Suggested Procedure

Procedure when PT100 and PTC are not used:

1. Momentarily bridge terminals Y11-Y12 (voltage-free contact). A spring return key switch is recommended.
2. LCD flashes “EMERGENCY START”.
3. If the thermal release has tripped, it can now be reset.
4. If the maximum number of starts per hour has been reached, the counter has one start deducted.
5. Start the motor.
6. As soon as the motor starts, the stator winding memory will be set to zero (copper losses only).

ATTENTION

Do not leave Y11-Y12 bridged, because each start will reset the copper memory



Additional procedure when PT100 and/or PTC are installed:

1. Disable PTC and/or PT100.

SET VALUES

PTC TRIP
OFF

PT100 #1...6 TRIP
OFF

2. Alternatively, the Smart Motor Manager can be set up such that inputs #1 and #2 deactivate the PTC and/or PT100 tripping. (This can be achieved with a separate switch or a separate set of contacts on the key switch, refer to page [3-52](#).)
3. The input should remain activated until the temperatures return to normal.

LED Alarm and Trip Indicator

The LED indicator on the front of the Smart Motor Manager differentiates between two kinds of indication:

- LED flashing, indicates an alarm
- LED continuously lit, indicates a tripped condition

Connection of the Main Relay (MR)

The main output relay can be operated as electrically held or non-fail-safe.

Electrically Held Mode

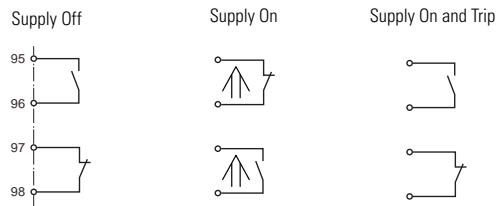

Non-Fail-Safe Mode

Note: Terminal markings should be changed from those used in electrically held mode when switching to this mode.

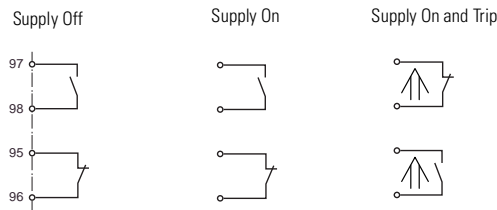

Applications of the Non-Fail-Safe Connection

The non-fail-safe connection is suitable for use in situations where the failure of the control voltage must not interrupt the process:

- Chemical processes
- Kneaders and mixers in which the mass would solidify
- Fresh air fans
- Cooling pumps, etc.

Connection of the Alarm Relay (AL)

In firmware versions before 2.18 the alarm relay was connected in the non-fail-safe mode. Since V2.18 (and later) it can also be connected in the electrically held mode.

Electrically Held Mode

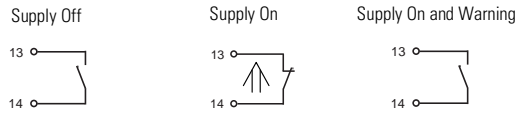

Non-Fail-Safe Mode

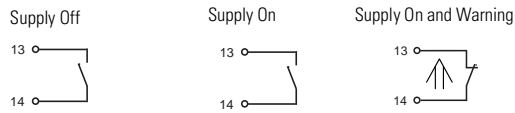

Applications of the Electrically Held Connection

Monitoring the supply voltage as well as operation of the communication option when the main relay is in non-fail-safe mode.

Alarm Relay AL

Aside from the thermal overload, short-circuit, and thermistor PTC protective functions, all alarm and tripping functions may be assigned to the alarm relay (AL).

Table 3.U Alarm Examples

Warning	Factory Setting
Thermal Utilization	75%
Asymmetry	20%
High Overload	$2 I_e$
Underload	75%
All these functions	Off

Reset

When the motor is at standstill, a trip condition can be reset.

Kinds of Reset

- Manual reset — Press the reset button on the Bulletin 825 for at least 200 ms
- Remote reset — Short circuit terminals Y21/Y22
- Automatic reset — In the mode “set values”, set automatic reset for:
 - Thermal trip
 - PTC trip
 - PT100 trip

Reset Conditions

- Thermal — As soon as the temperature rise has dropped to the preset reset threshold.
- PTC detector — As soon as the temperature is below the reset threshold
- PT100 detector — As soon as the temperature is below the tripping threshold.
- Asymmetry/Phase failure — Manual or remote reset possible
- All other trips — Can be reset immediately.

Table 3.V Reset Setting Parameters

Setting range	Manual/Automatic
Factory setting	Manual
Reset Threshold of the Thermal Trip	
Setting range	10...100%
Factory setting	70%
Setting increments	5%

Function of the Cat. No. 825-MST Option Card

Short-Circuit

Heavy phase currents caused by short circuits between phases and from phase to earth are detected by the Cat. No. 825-MST option card. The supply can be interrupted immediately by controlling the power switching device (e.g., circuit-breaker).

Short-circuit protection is always active. Therefore, the response level must be set somewhat higher than the maximum starting current.

Tripping is delayed by 50 ms. This enables the circuit breaker to be actuated rapidly while preventing unnecessary tripping by current peaks. In the event of a short-circuit, the separate output relay #1 trips, regardless of the other protective functions. The output relay #1 actuates a circuit breaker with adequate breaking capacity. To prevent the contactor from opening under short-circuit conditions, relay MR remains blocked at currents $\geq 12 I_e$. If a thermal trip occurred shortly before the short circuit, relay MR assumes the tripped position as soon as the current has dropped to $< 12 I_e$.

Figure 3.25 Interruption of a Short-Circuit

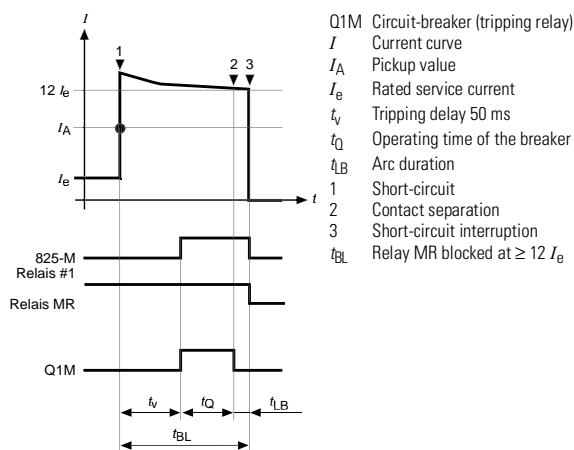

Application

- Medium/high-voltage motors

ATTENTION

The short-circuit protection function must not be used for switching off the contactor.



Table 3.W Short Circuit Setting Parameters

	Trip ❶
Function	
Factory setting	Off
Response Level	
Setting range	4...12 I_e
Factory setting	10 I_e
Setting increments	0.5 I_e
Tripping Delay	
Setting range	20...990 ms
Factory setting	50 ms
Setting increments	10 ms
Output Relay	
Selection (relays)	#1, No output relay
Factory setting	#1

❶ -5...60 °C (23...140 °F)

Earth (Ground) Fault Protection with a Core Balance Current Transformer

This function is integrated into the Cat. No. 825-MST option card. Refer to page 3-28.

Stalling During Start

Function

If the motor stalls during the starting phase, the motor heats up very rapidly reaching the temperature limit of the insulation after the permissible stalling time. Large, low-voltage motors, and especially medium- to high-voltage motors often have short, permissible stalling times, although their starts may be considerably longer. Accordingly, the permissible stalling time must be set higher on the basic unit in these instances. With an external speedometer or zero speed switch, the Smart Motor Manager recognizes that stalling has occurred during starting, and it switches the motor off immediately. Thus, the motor and the driven installation are not exposed to unnecessary or unacceptable stress from stalling.

Applications

- Large low-voltage motors
- Medium- and high-voltage motors
- Conveyor systems
- Mills
- Mixers
- Crushers
- Saws
- Cranes
- Hoists, etc.

Figure 3.26 Stalling During Starting

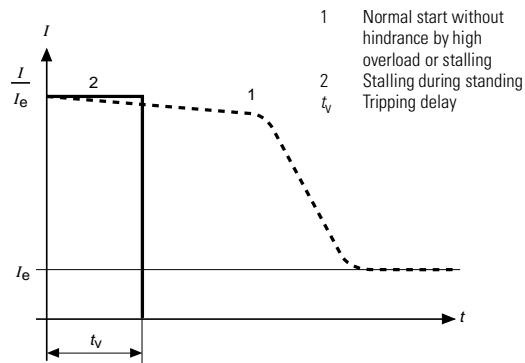

Table 3.X Stalling during Start Setting Parameters

	Function	Trip
Factory setting		Off
Tripping Delay		
Factory setting	The trip time t_{sp} depends on the trip time t_{ov} chosen for the overcurrent as follows: $t_{ov} < 400$ ms, $t_{sp} = 600$ ms.; $t_{ov} \geq 400$ ms, $t_{sp} = t_{ov} + 400$ ms.	
Actuation		
Message from zero speed switch to control input #1		
Motor running	24V AC/DC at control input #1	
Motor standstill	0V AC/DC at control input #1	
Output Relay		
Selection (relays)	Same relay as for function "High Overload and Jam" (settable only there)	

PTC Thermistor Input

Function

The thermistor detectors (PTCs) are embedded in the stator winding of the motor. They monitor the actual temperature of the winding. Influences independent of the motor current, such as ambient temperature, obstructed cooling, etc., are taken into account.

The detectors and their leads are monitored for short-circuit and open circuit.

Applications

As additional protection for:

- Motors above 7.5 kW (10 HP)
- High ambient temperatures, dusty environment
- Varying loads
- Plugging, etc.

Table 3.Y PTC Setting Parameters

Function	
Factory setting	Off
Output Relay ❶	
Selection (relays)	MR, AL, #1...#5
Factory setting	MR

- ❶ If auxiliary relays #2 and #3 are assigned to the communication (refer to page 5-16) they cannot be selected here.

Table 3.Z Sensor Measuring Circuit Specifications

Function						
Factory setting			Off			
Sensor Measuring Circuit						
Max. resistance of the PTC chain when cold			1.5 k Ω			
Max. number of sensors as per IEC 34-11-2			6			
Pickup value at $\delta_A = -5 \dots +60$ °C			3.3 k $\Omega \pm 0.3$ k Ω			
Dropout value at $\delta_A = -5 \dots +60$ °C			1.8 k $\Omega \pm 0.3$ k Ω			
Delay on pickup			800 ms \pm 200 ms			
Pickup value when short-circuit in sensors circuit at $\delta_A = -5 \dots +60$ °C			≤ 15 Ω			
Measuring voltage as per IEC 34-11-2			< 2.5V DC			
Measuring Lead						
Minimum cross-section	[mm ²]	0.5	0.75	1.0	1.5	2.5
	[AWG No.]	20	18	17	16	14
Maximum length	[m]	200	300	400	600	1 000
	[ft]	656	984	1 312	1 968	3 280
Method of installation ❶		up to 100 m (328 ft) twisted, unshielded				

- ❶ Twisted lead: 25 times twisted per m
 Screened lead: Screen connected to T2

Figure 3.27 Characteristic of PTC Sensors as per IEC 34-11-2

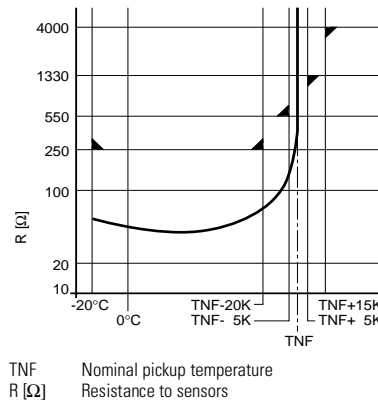

Analog Output

This output supplies a current of 4...20 mA proportional to one of the following selectable actual values:

- Thermal utilization (calculated temperature rise of the motor)
- Motor temperature (max. PT100 temperature)
- Motor current (% I_n)

Specifications

Output	4...20 mA (IEC 381-1) at -5...+60 °C (23...140 °F)
Load	0...300 Ω

Analog Output for Thermal Load or Motor Temperature (PT100 Max.)

This output supplies a current of 4...20 mA either proportional to the calculated temperature rise of the motor or the motor temperature (max. temperature of the operating PT100 Sensors). The thermal load in percentage is also indicated on the LCD of the Smart Motor Manager.

Application

- Local indication for continuous supervision of the load on motor and installation.
- Load control: With the indication of the momentary temperature rise of the machine, the load on the installation can be continuously controlled to the maximum permissible temperature rise of the motor. The result is optimal utilization of the motor with full protection and maximum productivity of the driven installation.
- Automatic load control by a controller or inverter drive (e.g., for charging mills and crushers; the Smart Motor Manager itself is unable to protect inverter-driven motors).

Figure 3.28 Analog Output for Motor Temperature Rise

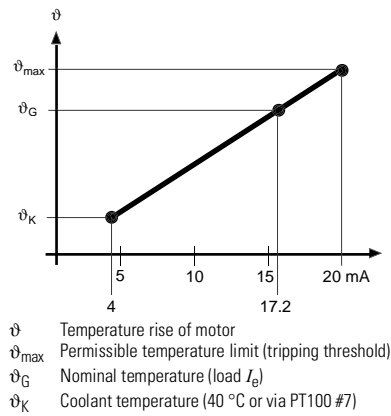

Thermal utilization calculation:

$$\text{Therm utiliz (\%)} = \frac{(\dots \text{mA} - 4 \text{ mA})}{16 \text{ mA}} \cdot 100\%$$

Figure 3.29 Analog Output for Motor Temperature

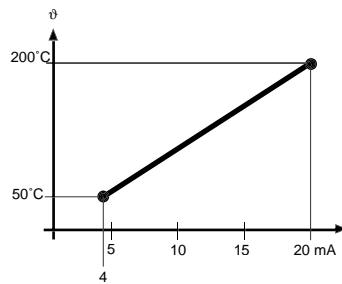

Motor Temperature calculation:

$$\text{Motor temp. (}^\circ\text{C)} = \frac{(\dots\text{mA} - 4\text{ mA})}{16\text{ mA}} \cdot 150\text{ }^\circ\text{C}$$

Analog Output for Motor Current

The output supplies a current of 4...20 mA proportional to the motor current.

Figure 3.30 Analog Output for Motor Current

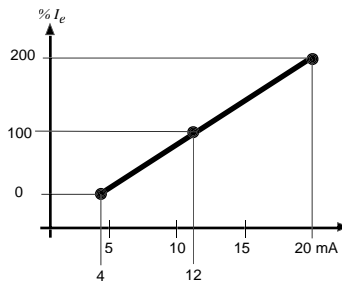

Motor current calculation:

$$\text{Motor current (\% } I_e) = \frac{(\dots\text{mA} - 4\text{ mA})}{16\text{ mA}} \cdot 200\% I_e$$

Control Inputs #1 and #2

With control inputs #1 and #2, the following control and protection functions are available:

- Timer functions
- Disabling of protection functions
- Protection against stalling during starting with an external speedometer (refer to page 3-44)
- Changing over to a second rated current (two-speed motor)

Actuation

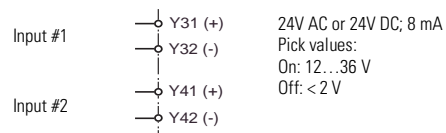

The control inputs are galvanically separated from the electronic circuits by optocouplers. The control inputs are activated by applying 24V AC or DC to Y31/Y32 or Y42/Y41.

For further information refer to [Chapter 9](#).

Timer Functions

The following functions can be programmed:

- On Delay (t_{on}) 0...240 s
- Off Delay (t_{off}) 0...240 s
- On and off delay 0...240 s

Assignment of the Output Relays

- Control input #1 to output relay #2
- Control input #2 to output relay #3

Figure 3.31 Operating Diagram for Timer Functions

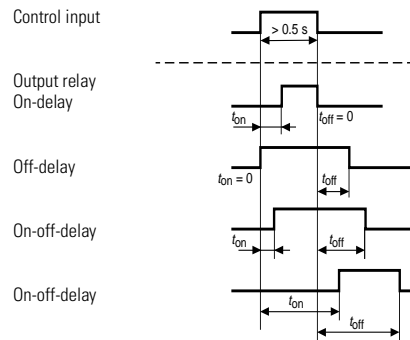

Applications

- Time-graded switching on and off
- Delaying the transfer of alarm and trip messages

Lock-Out of Protection Functions

With control inputs #1 and #2, one or more protective functions can be locked out as desired.

- Asymmetry (phase unbalance)
- High overload/jam
- Earth (ground) fault
- Short-circuit
- Underload
- Limiting the number of starts/hour
- PTC
- PT100

Applications

Lock-out of protection functions

During certain operational phases when the level differs from the normal values, such as:

- during starting: earth fault and short-circuit protection
- at no-load: protection against asymmetry and underload
- during brief overload phases: high overload/jam
- during commissioning and fault location (localizing the source of the trouble)

The selected functions are completely disabled as long as the control input is “on” (24V AC/DC).

- No alarm
- No trip, no reset
- Tripping delays begin to run only after the function is re-enabled.

Switching to a Second Rated Current

In the Smart Motor Manager, a second value can be selected for the rated current I_c . The change to the second rated value is controlled by activating control input #2 with 24V AC/DC.

Make sure the second rated current is compatible with the current range of the Cat. No. 825-MCM current converter module.

Application

- Two-speed motors
- Briefly increased loading of the motor and installation
- Maximum loading when the ambient temperature varies appreciably. Examples:
Exposed water pumps, different conveying capacities during, daytime and at night

Functions of the Cat. No. 825-MLV Option Card

Phase Sequence

Function

If a motor is switched on in the wrong direction of rotation, the installation can be adversely affected. The Smart Motor Manager monitors the phase sequence when voltage is applied, and prevents the motor starting in the wrong direction.

Applications

- Mobile installations (e.g., refrigerated transporters, construction machines)
- Installations that can be displaced as enclosed units (e.g., mobile crushers, conveyor belts, saws)
- If a reversed phase sequence must be expected after a repair.

Table 3.AA Phase Sequence Setting Parameters

Function	
Factory setting	Off
Tripping Delay	
Factory setting	1 s
Output Relay ①	
Selection (relays)	MR, AL, #1...#5
Factory setting	MR

- ① If auxiliary relays #2 and #3 are assigned to the communication (refer to page 5-16) they cannot be selected here.



ATTENTION

The phase sequence of the motor supply can be monitored only at the point of measurement (usually before the contactor). Exchanged leads between this point and the motor cannot be recognized.

Phase Failure (Based on Voltage Measurement)

Function

A phase failure is recognized by measuring the voltages before the switchgear and thus with the motor at standstill. (With phase failure protection where the phase currents are measured, the motor first has to be switched on, although it cannot start with only two phases.)

Table 3.AB Phase Failure Setting Parameters

Function	
Factory setting	Off
Tripping Delay	
Factory setting	2 s
Output Relay ①	
Selection (relays)	MR, AL, #1...#5
Factory setting	MR

- ① If auxiliary relays #2 and #3 are assigned to the communication (refer to page 5-16) they cannot be selected here.

Star-Delta (Wye-Delta) Starting

The Smart Motor Manager issues the command to switch from star to delta (wye to delta) as soon as the starting current has dropped to the rated value and thus the motor has reached its normal speed in star (wye). If starting has not been completed within the normal time for this application [max. star (wye) operation], a change to delta will be made, regardless of the speed attained.

The permissible time for star (wye) operation can be switched on or off as desired. If it is off, the change to delta is made solely with reference to the motor current.

If the motor has to be switched off when the normal starting time in star (wye) is exceeded, the “monitoring starting time” function must also be activated (refer to page 3-34).

Figure 3.32 Diagram of Star-Delta (Wye-Delta) Starting

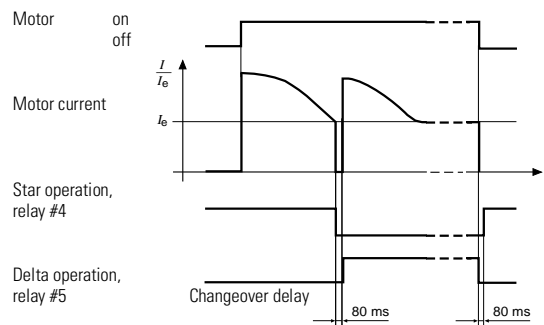

Table 3.AC Star-Delta (Wye-Delta) Starting Setting Parameters

Setting	Star (Wye) Relay	Delta Relay	Max. Star (Wye) Operation
Function			
Factory setting	—	Off	Off
Setting			
Setting range	—	—	1...240 s
Factory setting	Relay #4	Relay #5	10 s
Setting steps	—	—	1 s

Functions of the Cat. No. 825-MMV Option Card

PT100 (100 Ω Platinum) Temperature Sensor (RTD)

The PT100 temperature detectors are often embedded in the stator winding and/or the bearings, especially in large motors. The Smart Motor Manager monitors the actual stator, bearing, and coolant temperature. The resistance from a PT100 temperature detector is dependent on the temperature and has a positive temperature coefficient ($0.4 \Omega/^\circ\text{C}$).

Table 3.AD PT100 Temperature Detector Resistance per IEC 751

Temperature ($^\circ\text{C}$)	Resistance (Ω)
0	100.00
50	119.40
100	138.50
150	157.31
200	175.84

Sensors that are not connected must be switched off. Temperature sensors #1...#6 monitor the actual stator or bearing temperatures.

- The temperature is continuously indicated in $^\circ\text{C}$
- The alarm and tripping temperatures can be set as desired

Applications

- Large low voltage motors
- Medium- and high-voltage motors
- At high ambient temperatures
- When cooling is obstructed.

Table 3.AE PT100 (RTD) Setting Parameters

	Warning	Trip
Function		
Factory setting	Off	Off
Response Level		
Setting range	50...200 °C	50...200 °C
Factory setting	—	50 °C
Setting steps	—	1 °C
Tripping Delay		
Factory setting	< 8 s	< 8 s
Output Relay ①		
Selection (relays)	AL, #1...#3	MR, AL, #1...#3
Factory setting	AL	MR

- ① If auxiliary relays #2 and #3 are assigned to the communication (refer to page 5-16) they cannot be selected here.

ATTENTION

It is essential to set the “Warning” response level to a value less than the “Trip” response level.

PT100 #7 Temperature Sensor (RTD)

The PT100 #7 temperature sensor measures the ambient temperature or the coolant in the motor and indicates it in °C. The Smart Motor Manager takes into account the temperature of the coolant in the thermal image. The motor and the installation can be better used with deviating coolant temperatures.

PT100 PROT
ON

The temperature of the coolant/ambient temperature is indicated as soon as the function is activated and PT100 #7 is connected.

LCD of 825-M:

Tambient...°C

This function must be activated so that the coolant temperature may be taken into account in the thermal image:

Tamb IN TH IMAGE
ON

Ambient temperature in the thermal image is taken into account.

MOTOR INSULATION CLASS
B

Insulation class of winding

Table 3.AF Motor Insulation Class Setting Parameters

Function	
Factory setting	Off
Insulation Class	
Selection	B, E, F
Factory setting	B

Limiting winding temperatures of the three insulations classes: E = 120 °C, B = 130 °C, F = 155°C.

When the ambient temperature is taken into consideration, the insulation class needs to be programmed for correction of the thermal model. Without using PT100 #7 as the ambient temperature input, the thermal model bases the thermal calculation on an ambient temperature of 40°C.

Application

- With large temperature variation (day/night)
- Outdoor installations:
 - Pumps
 - Conveyors
 - Crushers
 - Saws

Assembly and Installation

Assembly

Flush Mounting

To mount the Smart Motor Manager in a front panel, cut a rectangular hole with the following dimensions.

Figure 4.1 Basic Unit Mounted in an Enclosure

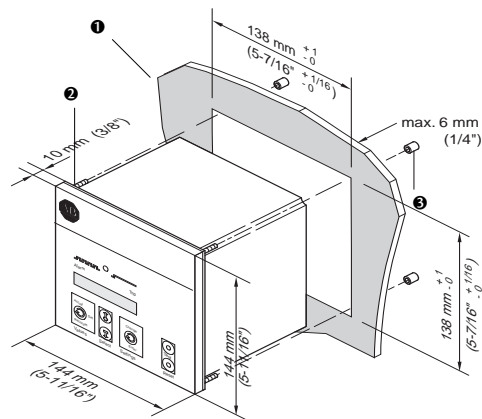

Dimensions in mm (inches)
 Dimensions:
 Panel cutout: 138 x 138 mm
 (-0 mm, +1 mm)
 Mounting depth: min. 140 mm

- ❶ Front panel with cutout
- ❷ Rubber gasket
- ❸ Fixing nuts

Mounting Position

Figure 4.2 Mounting Position

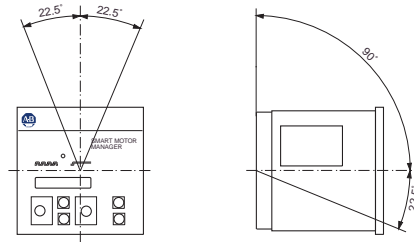

Surface Mounting

Figure 4.3 Basic Unit Mounted into Panel Mounting Frame (Cat. No. 825-FPM)

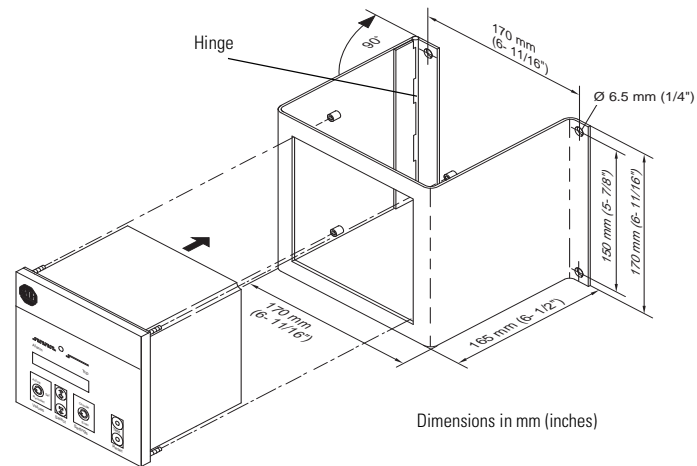

Converter Modules

Figure 4.4 Cat. Nos. 825 MCM2, 825-MCM-20, 825-MCM180

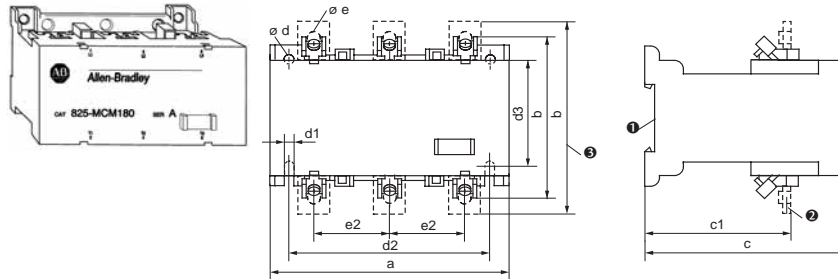

Table 4.A Cat. Nos. 825 MCM2, 825-MCM-20, 825-MCM180

Dimensions in millimeters (inches)

Cat. No. 825-	a	b	c	c1	Ø d	d1	d2	d3	Ø e	Ø e1	e2	b1	b2
MCM2	120 (4-45/64)	85 (3-23/64)	102 (4)	66 (2-39/64)	5.3 (3/16)	5.3 (3/16)	100 (3-7/8)	55 (2-3/16)	2 x 2.5 mm ²	—	38.5 (1-1/2)	—	—
MCM20	120 (4-45/64)	85 (3-23/64)	102 (4)	66 (2-39/64)	5.3 (3/16)	5.3 (3/16)	100 (3-7/8)	55 (2-3/16)	2 x 2.5 mm ²	—	38.5 (1-1/2)	—	—
MCM180	120 (4-45/64)	—	102 (4)	72 (2-13/16)	5.3 (3/16)	5.3 (3/16)	100 (3-7/8)	55 (2-3/16)	M8	M8	38.5 (1-1/2)	75 (2-61/64)	③④ 100/117

- ① Mounted on DIN Rail EN 50 022-35
- ② Bus bar or opening for conductor max. Ø 19 mm
- ③ With Cat. No. 825-MVM
- ④ With Cat. No. 825-MVM2

Figure 4.5 Cat. Nos. 825-MCM630, 825-MCM630N

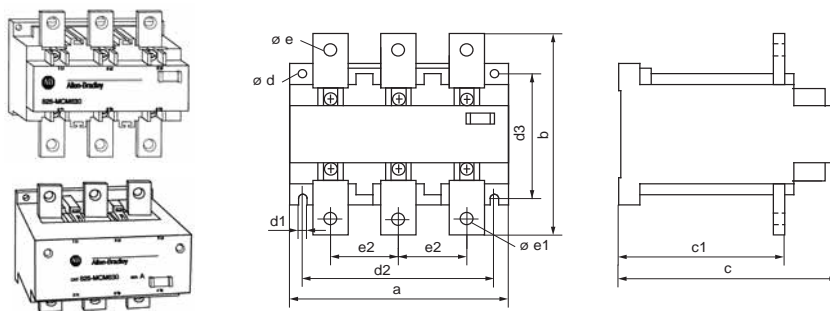

Table 4.B Cat. Nos. 825-MCM630, 825-MCM630N

Dimensions in millimeters (inches)

Cat. No.	a	b	c	c1	Ø d	d1	d2	d3	Ø e1	e2
825-MCM630	155 (6-7/64)	145 (5-11/16)	156 (6-1/8)	118 (4-5/8)	6.3 (1/4)	6.3 (1/4)	135 (5-5/16)	88 (3-7/16)	M10	48 (1-7/8)
825-MCM630N	155 (6-7/64)	145 (5-11/16)	177 (6-31/32)	118 (4-5/8)	6.3 (1/4)	6.3 (1/4)	135 (5-5/16)	88 (3-7/16)	M10	48 (1-7/8)

Thermal Utilization Indicator

Figure 4.6 Cat. No. 825-MTUM Thermal Utilization Indicator

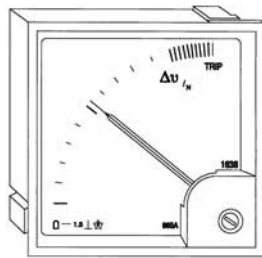

Panel cutout: 91.5 x 91.5 mm (3-39/64" x 3-39/64")
 (-1 mm [-1/16"] + 0.5 mm [+1/32"])

Mounting depth: 55 mm (2-3/16")

Wire size: 2 x 2.5 mm² (14 AWG)

ATTENTION

To retrofit or replace options, the assembly and testing instructions supplied with the option must be followed exactly.



Figure 4.7 Basic Unit Housing with Option Cards

Normally the basic unit will be ordered and shipped with the required option cards.

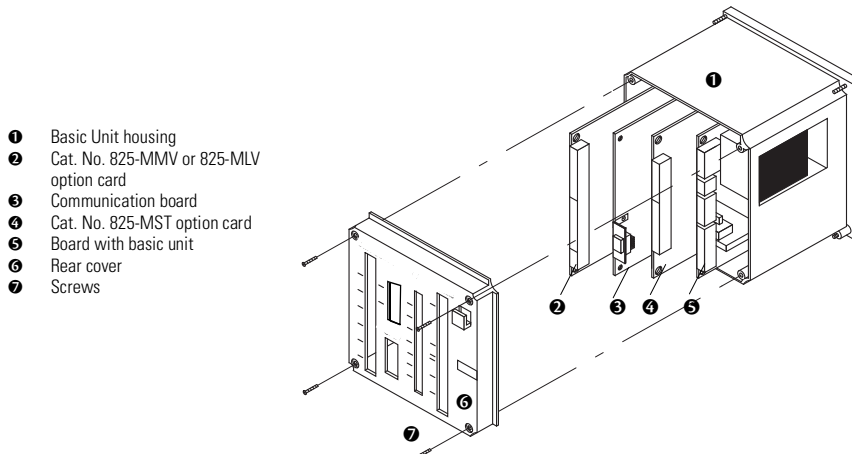

Installation and Wiring

General

The Smart Motor Manager fulfills the stringent requirements imposed by global standards requirements regarding electromagnetic compatibility (EMC). This means that there is no need to observe any special stipulations when wiring the unit.

Nevertheless, control leads should be laid separately from power leads. In the circuit diagrams throughout this section, any special wiring requirements are specifically noted.

The data of the output circuits and control inputs are dealt with in [Chapter 2, Specifications — Basic Unit and Converter Module](#). Throughout this manual, the contacts of the output relays are shown in their normal working position (i.e., the Smart Motor Manager control voltage is switched on, no warning, no trip).

ATTENTION



All assembly and installation work must be performed by qualified personnel, taking local codes into account.

Main Circuits

Basic Unit and Converter Module without Main Current Transformer

Figure 4.8 Basic Unit with Converter Module

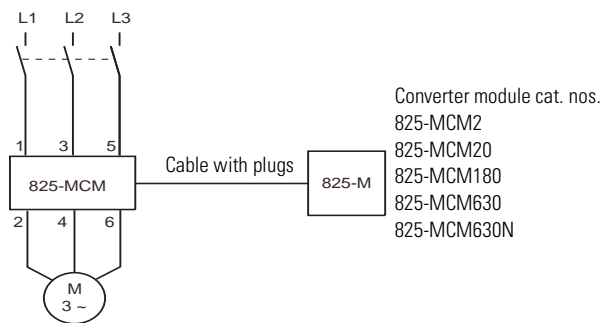

Basic Unit and Converter Module with Main Current Transformer

Figure 4.9 3-Phase Current Evaluation

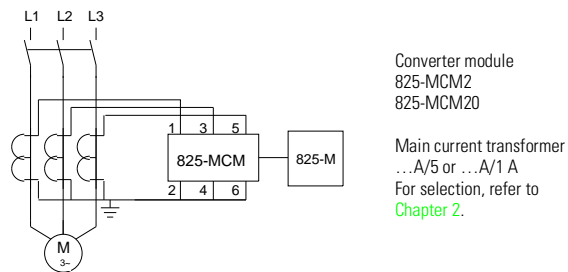

Basic Unit and Converter Module with Main and Core Balance Current Transformer

Figure 4.10 2-Phase Current Evaluation

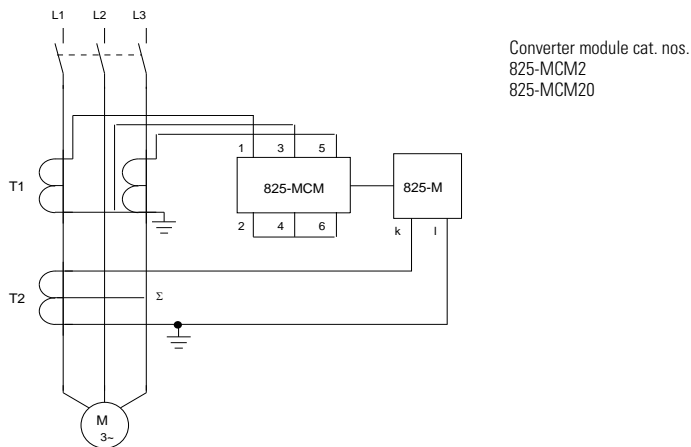

Table 4.C Specifications

Main current transformer (refer to Chapter 2 for selection information)	A/5 A or A/1 A
Core Balance Current Transformer	
Earth-/ground current	5 mA...50 A
Current ratio of core balance current transformer	1...2 000:1
Output from core balance current transformer	0...500 mA

Additional circuit diagrams can be found in [Chapter 9](#).

Control Circuits

Figure 4.11 Smart Motor Manager Basic Unit

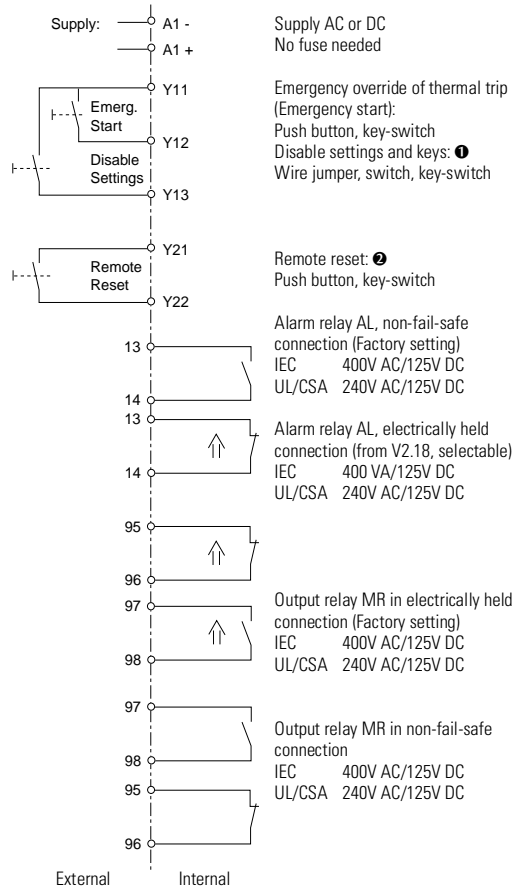

- ❶ Setting via communication is also disabled, as well as Test and Reset
- ❷ The remote reset is always active

Figure 4.12 Cat. No. 825-MST Option Card

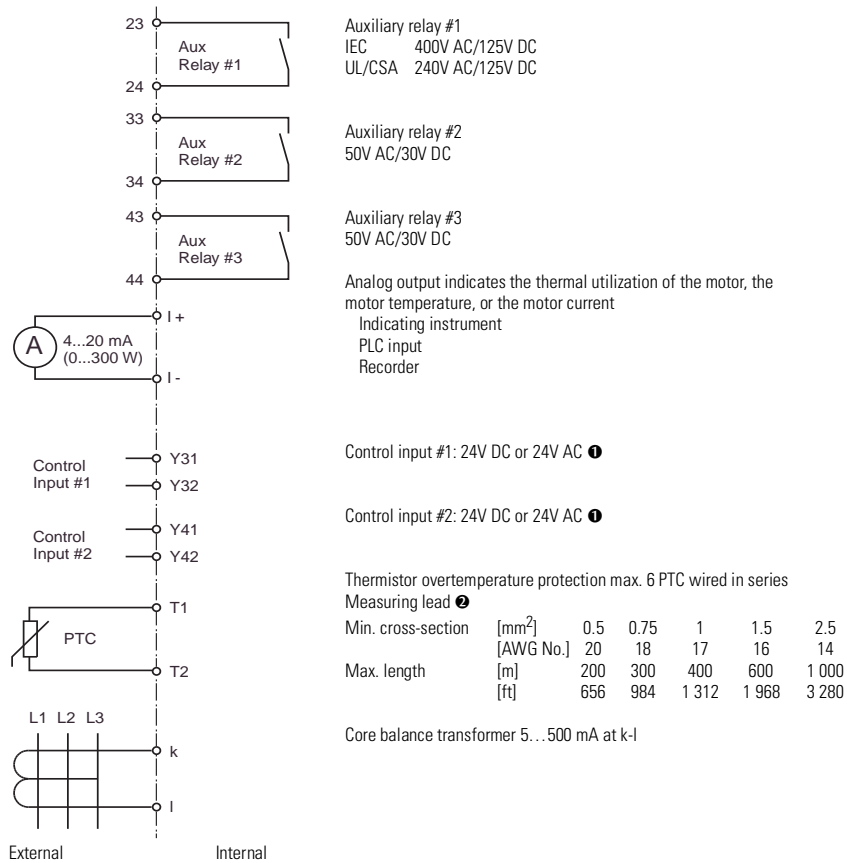

- ① For information regarding methods of actuation, refer to [Chapter 9](#).
- ② Method of installation: up to 100 m (328 ft) twisted, more than 100 m additional unshielded

Figure 4.13 Cat. No. 825-MLV Option Card

ATTENTION

Either the 825-MLV or 825-MMV option card may be inserted in this position.

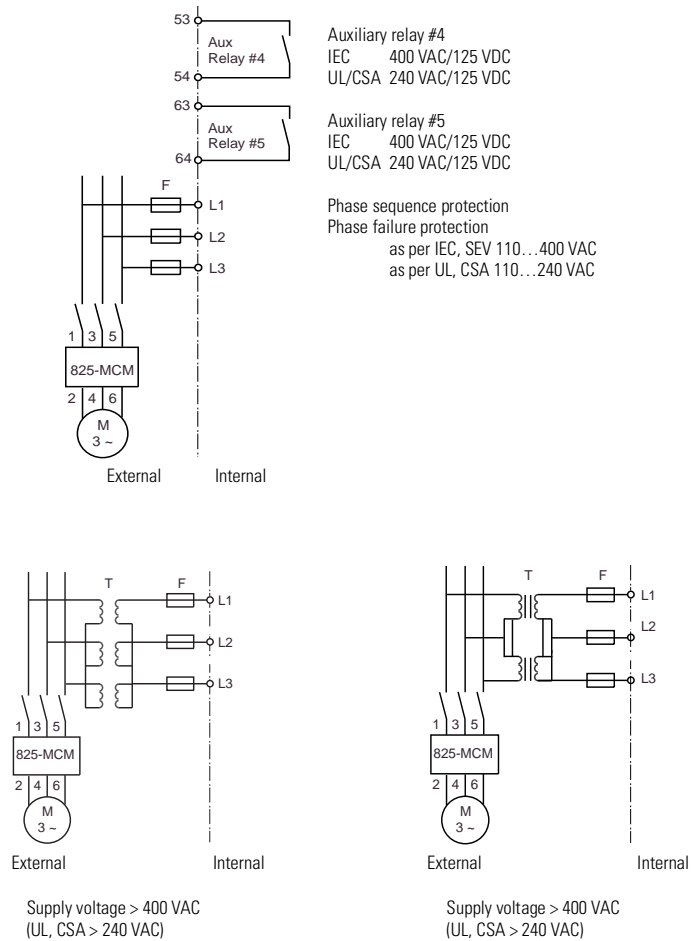
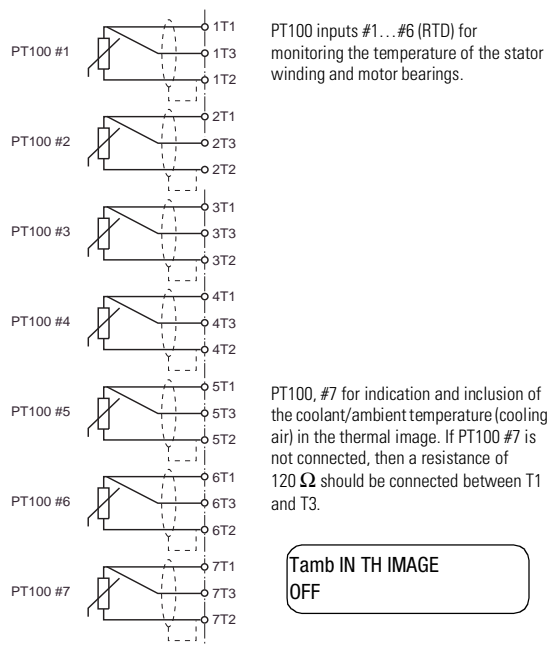

Figure 4.14 Cat. No. 825-MMV Option Card

ATTENTION

Either the 825-MLV or 825-MMV option cards may be inserted in this position.



Method of Installation

- Short links (up to 10 m) laid separate from power cables need no screening.
- Longer leads must be screened/shielded
 - Separately screened: connect screens to individual T2 (e.g., 1T2, 2T2...)
 - Common screening: connect screen to T2, and all T2 together (e.g., 1T2, 2T2...)

Option Communication

ATTENTION

Only one of the following options can be inserted at a time.



Cat. No. 825-MDN for DeviceNet Connection

Refer to Publication 825-UM002A-US-P

For more DeviceNet components refer to Publication B113

Cat. No. 3600-RIO for RI/O Connection

Refer to ProSoft 3600-RIO User Manual

Cat. No. 3600-MBS for Modbus Connection

Refer to ProSoft 3600-MBS User Manual

Setting the Operational Parameters

Menu Overview

All operating parameters can easily be set or altered at any time, using the four operating keys on the front of the unit. This procedure is described in [Chapter 3](#).

ATTENTION



All parameters of option cards can be programmed/set even when the option cards are not installed. Verify product configuration before commissioning.

Main Settings

The main settings have to be individually set for each motor.

Table 5.A Main Settings

Parameter	Setting range	Factory setting
Rated motor current or service current I_e	0.5...2 000 A	20 A
Current ratio of primary current transformer ❶	1...2 000	1
Locked-rotor current	2.5...12 I_e	6 I_e
Locked-rotor time ❷	1...600 s	10 s

- ❶ Accessing this parameter requires that the parameter *Primary CT* be set to "yes".
- ❷ If, instead of the permissible locked-rotor time, the maximum starting time is known, the approximate locked-rotor time is calculated as follows:

$$\text{Locked-rotor time} \approx \frac{\text{Starting time}}{1.4}$$

All other parameters, such as overcurrent, underload, asymmetry, etc., are set in the factory to values that are correct for the majority of applications. These factory-set values can be changed if requirements differ. The same applies to special settings.

Special Settings

These values are factory set to values that are correct for the majority of applications and should only be changed when requirements are outside the parameters allowed for by the factory settings.

Table 5.B Special Settings

Parameter	Setting range	Factory setting
Connection of main relay (MR)	Electrically held/non-fail-safe	Electrically held
Reset of thermal trip	Manual/auto	Manual
Reset at...% thermal utilization	10...100%	50%
Reset PTC trip	Manual/auto	Manual
Cooling constant ratio motor off/on	1...10	2.5
Motor insulation class ❶	B, E, F	B

❶ Motor insulation class needs to and can be set only if PT100 #7 (RTD) is included in the thermal image.

ATTENTION

Do not exceed the permissible values quoted by the motor manufacturer.



5-3 Setting the Operational Parameters

Table 5.C Communication Settings

Parameter	Setting Range	Factory Setting
DeviceNet		
Station number (MAC ID)	0...63	2
Baud rate: 125/250/500 kbaud	0...2	2
Remote I/O		
Station number	0...63	2
Baud rate ①	0...23	4
Baud rate ②	0...118	5
Modbus		
Station number	0...247	2
Baud rate ①	0...182	4
Baud rate ②	0...118	5
PROFIBUS		
Station number, Baud rate 9.6/19.2/73.75/187.5/500 kbaud	1...126 0...4	2 4 (500 kbd)

① Baud Rate for Remote I/O

Calculated according to the following formula:

Value = (8 x baud) + (4 x last_rack) + starting_mod_group

Baud: 0 = 57.6 kbaud, 1 = 115.2 kbaud, 2 = 230.4 kbaud

last_rack: 0 = no, 1 = yes

starting_mod_group: 0 = group 0, 1 = group 2, 2 = group 4,
3 = group 6

The rack_size is fixed to 1/4 rack.

② Baud Rate for DF1

Calculated according to the following formula:

Value = (64 x mode) + (32 x stop_bits) + (8 x parity) + baud

Mode: Data protection: 0 = CRC, 1 = BCC

stop_bits: 0 = 1 stop bit, 1 = 2 stop bit

parity: 0 = none, 1 = odd, 2 = even

baud: 0 = 300 baud, 1 = 600 baud, 2 = 1 200 baud,
3 = 2 400 baud, 4 = 4 800 baud, 5 = 9 600 baud,
6 = 19 200 baud

③ Baud Rate for Modbus

Calculated according to the following formula:

Value = (64 x mode) + (32 x stop_bits) + (8 x parity) + baud

Mode: Protocol: 0 = RTU, 1 = ASCII 7 bit, 2 = ASCII 8 bit

stop_bits: 0 = 1 stop bit, 1 = 2 stop bit

parity: 0 = none, 1 = odd, 2 = even

baud: 0 = 300 baud, 1 = 600 baud, 2 = 1 200 baud,
3 = 2 400 baud, 4 = 4 800 baud, 5 = 9 600 baud,
6 = 19 200 baud

Operating Parameters

Table 5.D Cat. No. 825-M... Operating Parameters

Group	Required Option Card Cat. No.	LCD	Setting Range	Description
Main settings	—	SET VALUES	—	Mode: Set parameters
	—	FULL LOAD CURR 20 A	0.5...2 000	Rated motor current in A
	—	PRIMARY C.T. #1 NO	No/Yes ❶	Use of the primary transformer
	—	PRIM. C.T. RATIO 1	1...2 000	Current ratio of the primary current transformer e.g. 500 A/5 A, setting = 100 800 A/5 A, setting = 160
	—	LOCKED ROT CURR 6 x I _e	2.5...12	Locked rotor and starting current in ...I _e
	—	LOCKED ROT TIME 10 sec	1...600	Maximum permissible locked-rotor time of motor from cold
Thermal overload	—	THERMAL TRIP MAIN RELAY	Main relay/no relay	Thermal trip, motor Choice between main output relay and no relay
	—	THERMAL WARNING OFF	On/Off ❷	Thermal warning (motor temp) On/Off
	—	TH WARNING LEVEL 75 %	50...99	Pickup value for thermal warning temperature rise as percent of thermal utilization
	—	TH WARNING ALARM RELAY	All except main relay	Thermal warning Assignment of output relay

❶ If *Primary CT #1* is set to "no", the programming menu skips to parameter *Locked Rot Curr*.

❷ If *Thermal Warning* is set to "off", the programming menu skips to parameter *Asymmetry Trip*.

Table 5.D Cat. No. 825-M... Operating Parameters (Continued)

Group	Required Option Card Cat. No.	LCD	Setting Range	Description
Asymmetry	—	ASYMMETRY TRIP ON	On/Off ❶	Asymmetry protection (current measuring asymmetry) On/Off
	—	AS TRIP LEVEL 35 %	5...80	Asymmetry trip Tripping level in percent
	—	AS TRIP TIME 2.5 sec	1...25	Asymmetry trip Tripping delay
	—	ASYMMETRY TRIP MAIN RELAY	All relays	Asymmetry trip Assignment of relays
	—	AS WARNING OFF	On/Off ❷	Asymmetry warning On/Off
	—	AS WARNING LEVEL 20 %	5...80	Asymmetry warning Warning level in percent
	—	AS WARNING ALARM RELAY	All except main relay	Asymmetry warning Assignment of output relay
Overcurrent	—	OVERCURR TRIP ON	On/Off	Overcurrent/locked-rotor protection On/Off
	—	OC TRIP LEVEL 2.4 x I _e	1.0...6.0	Overcurrent/locked-rotor Tripping level in ... I _e
	—	OC TRIP TIME 0.5 sec	0.1...5	Overcurrent/locked-rotor Tripping delay
	—	OVERCURRENT TRIP MAIN RELAY	All relays	Overcurrent/locked-rotor Assignment of output relay
	—	OC WARNING OFF	On/Off ❸	Overcurrent/locked-rotor warning On/Off

- ❶ If *Asymmetry Trip* is set to "off", the programming menu skips to parameter *AS Warning*.
- ❷ If *AS Warning* is set to "off", the programming menu skips to parameter *Overcurr Trip*.
- ❸ If *OC Warning* is set to "off", the programming menu skips to parameter *Earth Fault Prot*.

Table 5.D Cat. No. 825-M... Operating Parameters (Continued)

ATTENTION

Ensure that the trip function is reset before it is inactivated.



Group	Required Option Card Cat. No.	LCD	Setting Range	Description
Overcurrent, continued	—	OC WARNING LEVEL 2.0 x I _e	1.0...6.0	Overcurrent/locked-rotor Warning level in... I _e
	—	OC WARNING ALARM RELAY	All except main relay	Overcurrent/locked-rotor warning Assignment of output relay
Earth (ground) fault (Holmgreen/residual)	—	EARTH FAULT PROT ON	On/Off ❶	Earth (ground) fault protection On/Off
	—	EF HOLMG TRIP ON	On/Off ❷	Earth (ground) fault protection (Holmgreen = residual) On/Off
	—	EF H TRIP LEVEL 50 %	10...100	Earth (ground) fault trip (Holmgreen = residual) Tripping level, percent of motor current
	—	EF H TRIP TIME 0.50 sec	0.1...5	Earth (ground) fault trip (Holmgreen = residual) Tripping delay
	—	EF HOLMG TRIP MAIN RELAY	All relays	Earth (ground) fault trip (Holmgreen = residual) Assignment of output relay

❶ If *Earth Fault Prot* is set to "off", the programming menu skips to parameter *Short Circ Trip*.❷ If *EF Holmg Trip* is set to "off", the programming menu skips to parameter *EF Core Trip*.

Table 5.D Cat. No. 825-M... Operating Parameters (Continued)

Group	Required Option Card Cat. No.	LCD	Setting Range	Description
Earth (ground) fault	825-MST	EF CORE TRIP OFF	On/Off ❶	Earth (ground) fault protection (core balance transformer) On/Off
		CORE C.T. RATIO 1	1...2 000	Core balance transformer current ratio
		EF C TRIP LEVEL 1 A	5...999 mA 1.00...50.00 A	Earth (ground) fault trip (core balance transformer) Tripping level
		EF C TRIP TIME 0.50 sec	0.1...5	Earth (ground) fault trip (core balance transformer) Tripping delay
		EF CORE TRIP MAIN RELAY	All relays	Earth (ground) fault warning (core balance transformer) Assignment of output relay
		EF C WARNING OFF	On/Off ❷	Earth (ground) fault warning (core balance transformer) On/Off
		EF C WARN LEVEL 500 mA	5...999 mA 1.00...50.00 A	Earth (ground) fault warning (core balance transformer) Tripping level
		EF C WARNING ALARM RELAY	All except main relay	Earth (ground) fault warning (core balance transformer)
Short circuit	825-MST	SHORT CIRC TRIP OFF	On/Off ❸	Short-circuit protection On/Off (h.v. motors only)
		SC TRIP LEVEL 10.00 x I _e	4.0...12.0	Short-circuit trip Tripping level... I _e
		SC TRIP TIME 50 ms	20...990	Short-circuit trip Tripping delay
		SHORT CIRC TRIP AUX RELAY #1	Relay #1/ no relay	Short-circuit trip, choice between output relay #1 and no relay

- ❶ If *EF Core Trip* is set to "off", the programming menu skips to parameter *EF C Warning*.
- ❷ If *EF C Warning* is set to "off", the programming menu skips to parameter *Short Circ Trip*.
- ❸ If *Short Circ Trip* is set to "off", the programming menu skips to parameter *Underload Trip*.

Table 5.D Cat. No. 825-M... Operating Parameters (Continued)

Group	Required Option Card Cat. No.	LCD	Setting Range	Description
Underload	—	UNDERLOAD TRIP OFF	On/Off ❶	Underload protection On/Off
	—	UL TRIP LEVEL 75 % I _e	25...100	Underload trip Tripping level... % I _e
	—	UL TRIP TIME 10 sec	1...60	Underload trip Tripping delay
	—	UNDERLOAD TRIP MAIN RELAY	All relays	Underload trip Assignment of output relay
	—	UL START-DELAY 0 sec	0...240	Underload trip Start delay
	—	UL WARNING OFF	On/Off ❷	Underload warning On/Off
	—	UL WARNING ALARM RELAY	All except main relay	Underload warning, assignment of output relay (warning level is equal to tripping level, without tripping delay)
Star-Delta (Wye-Delta) starting	825-MLV	STAR DELTA OFF	On/Off ❸	Star-delta starting On/Off
		STAR AUX REL #4	Relay#4	Star-delta starting Assignment of star output relay
		DELTA AUX REL #5	Relay#5	Star-delta starting Assignment of delta output relay
		SET STAR TIME OFF	On/Off ❹	Star-delta starting Max. time on star on/off
		STAR TIME 10 sec	1...240	Star-delta starting Max. time on star

❶ If *Underload Trip* is set to "off", the programming menu skips to parameter *UL Warning*.

❷ If *UL Warning* is set to "off", the programming menu skips to parameter *Star Delta*.

❸ If *Star Delta* is set to "off", the programming menu skips to parameter *Warm Starting*.

❹ If *Set Star Time* is set to "off", the programming menu skips to parameter *Warm Starting*.

Table 5.D Cat. No. 825-M... Operating Parameters (Continued)

Group	Required Option Card Cat. No.	LCD	Setting Range	Description
Warm start	—	WARM STARTING OFF	On/Off ❶	Warm start On/Off
	—	WARM START EACH 60 min	4...60	Warm start possible every ___min.
	—	WARM TRIP TIME 70 %	50...100	Warm start tripping time as a percentage of tripping time from cold
Limiting number of starts per hour	—	START INHIBIT OFF	On/Off ❷	Limiting number of starts/hour On/Off
	—	MAX START/HOUR 2	1...10	Maximum starts/hour
	—	START INHIB TRIP MAIN RELAY	All relays	Maximum number of starts/hour reached Assignment of output relay
Monitoring startup time	—	START CONTROL OFF	On/Off ❸	Monitoring starting time On/Off
	—	START TIME 10 sec	1...240	Maximum starting time
	—	START CONT TRIP MAIN RELAY	All relays	Starting time exceeded Assignment of output relay

❶ If *Warm Starting* is set to "off", the programming menu skips to parameter *Start Inhibit*.

❷ If *Start Inhibit* is set to "off", the programming menu skips to parameter *Start Control*.

❸ If *Start Control* is set to "off", the programming menu skips to parameter *Main Relay*.

Table 5.D Cat. No. 825-M... Operating Parameters (Continued)

Group	Required Option Card Cat. No.	LCD	Setting Range	Description
Special settings	—	MAIN RELAY ELECTR. HELD	Electrically held/non fail-safe	Main output relay in electrically held or non fail-safe connection
	—	ALARM RELAY NON-FAIL-SAFE	Electrically held/non fail-safe	Alarm relay in non-fail-safe or electrically held connection
	—	TH TRIP RESET MANUAL	Manual/auto	Reset of thermal trip Manual/automatic
	—	THE RESET LEVEL 50 %	10...100	Thermal reset at ___% of thermal utilization
	—	COOL-CONST RATIO 2.5	1.0...10.0	Cooling constant ratio between "motor off" and "motor on"
PTC temperature sensors	825-MST	PTC TRIP ON	On/Off ❶	Thermistor protection PTC On/Off
		PTC TRIP MAIN RELAY	All relays	PTC trip Assignment of output relay
		PTC RESET MANUAL	Manual/auto	Reset PTC trip Manual/automatic
Control input #1	825-MST	CONTROL INPUT #1 OFF	On/Off ❷	Control input #1 On/Off
		DELAY AUX REL #2 OFF	On/Off ❸	Timer function of auxiliary relay #2 On/Off
		ON DELAY AUX #2 1 sec	0...240	On-delay of auxiliary relay #2
		OFF DELAY AUX #2 2 sec	0...240	Off-delay of auxiliary relay #2 ❹

❶ If *PTC Trip* is set to "off", the programming menu skips to parameter *Control Input #1*.

❷ If *Control Input #1* is set to "off", the programming menu skips to parameter *Control Input #2*.

❸ If *Delay Aux Rel #2* is set to "off", the programming menu skips to parameter *Speed Switch*.

❹ After *Off Delay Aux #2* is set, the programming menu skips to parameter *Control Input #2*.

Table 5.D Cat. No. 825-M... Operating Parameters (Continued)

Group	Required Option Card Cat. No.	LCD	Setting Range	Description
Control input #1, continued	825-MST	SPEED SWITCH OFF	On/Off ❶	Speed switch/stop indicator (locked-rotor during start) On/Off and/or auxiliary contact of motor contactor "motor switched on" for motors with $I_m < 20\% I_e$.
		SS TRIP TIME 0.9 SEC		Trip time t_{sp} depends on the trip time chosen for the overcurrent t_{ov} as follows: $t_{ov} < 400$ ms, $t_{sp} = 600$ ms $t_{ov} \geq 400$ ms, $t_{sp} = t_{ov} + 400$ ms
		SS TRIP MAIN RELAY		Trip on relay chosen for overcurrent/locked-rotor
		DISABLE FUNCTION OFF	On/Off ❷	Disable protective function On/Off
		ASYMMETRY PROT NOT DISABLED	Not disabled/ disabled	Asymmetry protection Active/locked out
		OVERCURRENT PROT NOT DISABLED	Not disabled/ disabled	Overcurrent/locked-rotor protection Active/locked out
		EARTH FAULT PROT NOT DISABLED	Not disabled/ disabled	Earth-fault protection Active/locked out
		SHORT CIRC PROT NOT DISABLED	Not disabled/ disabled	Short-circuit protection Active/locked out
		UNDERLOAD PROT NOT DISABLED	Not disabled/ disabled	Underload protection Active/locked out
		START INHIBIT NOT DISABLED	Not disabled/ disabled	Limiting starts/hour Active/locked out
		PTC PROT NOT DISABLED	Not disabled/ disabled	PTC protection Active/locked out
		PT100 PROT NOT DISABLED	Not disabled/ disabled	PT100 (RTD) protection Active/locked out

❶ If *Speed Switch* is set to "off", the programming menu skips to parameter *Disable Function*.

❷ If *Disable Function* is set to "off", the programming menu skips to parameter *Control Input #2*.

Table 5.D Cat. No. 825-M... Operating Parameters (Continued)

Group	Required Option Card Cat. No.	LCD	Setting Range	Description
Control input #2	825-MST	CONTROL INPUT #2 OFF	On/Off ❶	Control input #2 On/Off
		DELAY AUX REL #3 OFF	On/Off ❷	Timer function of output relay #3 On/Off
		ON DELAY AUX #3 1 sec	0...240	On-delay of output relay #3
		OFF DELAY AUX #3 2 sec	0...240	Off-delay of output relay #3 ❸
		NEW FLC OFF	On/Off ❹	Setting 2nd rated motor current Off/On
		PRIMARY C.T. #2 NO	No/Yes ❺	Use of primary c.t. for 2nd rated motor current
		PRIMARY C.T. RATIO 1	1... 2 000	Current ratio of primary c.t. e.g. 800 A/5 A, setting = 160
		NEW FLC 20 A	0.50... 2 000	Setting 2nd rated motor current On/Off
		DISABLE FUNCTION OFF	Not disabled/ disabled ❻	Disable protective function On/Off
		ASYMMETRY PROT NOT DISABLED	Not disabled/ disabled	Asymmetry protection Active/locked out
		OVERCURRENT PROT NOT DISABLED	Not disabled/ disabled	Overcurrent/locked-rotor protection Active/locked out
		EARTH FAULT PROT NOT DISABLED	Not disabled/ disabled	Earth-fault protection Active/locked out
SHORT CIRC PROT NOT DISABLED	Not disabled/ disabled	Short-circuit protection Active/locked out		

- ❶ If *Control Input #2* is set to "off", the programming menu skips to parameter *Phase-Rever Trip*.
- ❷ If *Delay Aux Rel #3* is set to "off", the programming menu skips to parameter *New FLC*.
- ❸ After *Off Delay Aux #3* is set, the programming menu skips to parameter *Phase-Rever Trip*.
- ❹ If *New FLC* is set to "off", the programming menu skips to parameter *Disable Function*.
- ❺ If *Primary C.T. #2* is set to "no", the programming menu skips to parameter *New FLC*.
- ❻ If *Disable Function* is set to "off", the programming menu skips to parameter *Phase-Rever Trip*.

Table 5.D Cat. No. 825-M... Operating Parameters (Continued)

Group	Required Option Card Cat. No.	LCD	Setting Range	Description
Control input #2, continued	825-MST	UNDERLOAD PROT NOT DISABLED	Not disabled/ disabled	Underload protection Active/locked out
		START INHIBIT NOT DISABLED	Not disabled/ disabled	Limiting starts/hour Active/locked out
		PTC PROT NOT DISABLED	Not disabled/ disabled	PTC protection Active/locked out
		PT100 PROT NOT DISABLED	Not disabled/ disabled	PT100 (RTD) protection Active/locked out
Phase sequence protection	825-MLV	PHASE-REVER TRIP OFF	On/Off ❶	Phase sequence protection (based on motor supply voltage) On/Off
		PHASE-REVER TRIP MAIN RELAY	All relays	Phase sequence protection Assignment of output relay
Phase failure	825-MLV	PHASE LOSS TRIP OFF	On/Off ❷	Phase failure (based on motor supply voltage) On/Off
		PHASE LOSS TRIP MAIN RELAY	All relays	Phase failure Assignment of output relay
PT 100 (RTD) temperature sensor	825-MMV	PT100 PROT OFF	On/Off ❸	PT100 protection (stator/bearings) On/Off
		PT100 #1 TRIP OFF	On/Off	PT100 #1 protection On/Off
		#1 TRIP TEMP 50 °C	50...200	PT100 #1 Tripping temperature
		PT100 #2 TRIP OFF	On/Off	PT100 #2 protection On/Off
		#2 TRIP TEMP 50 °C	50...200	PT100 #2 Tripping temperature

❶ If *Phase-Rever Trip* is set to "off", the programming menu skips to parameter *Phase Loss Trip*.

❷ If *Phase Loss Trip* is set to "off", the programming menu skips to parameter *PT100 Prot*.

❸ If *PT100 Prot* is set to "off", the programming menu skips to parameter *Output 4...20 mA*.

Table 5.D Cat. No. 825-M... Operating Parameters (Continued)

Group	Required Option Card Cat. No.	LCD	Setting Range	Description
PT 100 (RTD) temperature sensor, continued	825-MMV	PT100 #3 TRIP OFF	On/Off	PT100 #3 protection On/Off
		#3 TRIP TEMP 50 °C	50...200	PT100 #3 Tripping temperature
		PT100 #4 TRIP OFF	On/Off	PT100 #4 protection On/Off
		#4 TRIP TEMP 50 °C	50...200	PT100 #4 Tripping temperature
		PT100 #5 TRIP OFF	On/Off	PT100 #5 protection On/Off
		#5 TRIP TEMP 50 °C	50...200	PT100 #5 Tripping temperature
		PT100 #6 TRIP OFF	On/Off	PT100 #6 protection On/Off
		#6 TRIP TEMP 50 °C	50...200	PT100 #6 Tripping temperature
		PT100 #1-6 TRIP MAIN RELAY	All relays ex 4, 5	PT100 #1...#6 Tripping
		PT100 #1-6 RESET MANUAL	Manual/ auto	PT100 #1...#6, reset PT100 trip Manual/automatic
		PT100 #1 WARNING OFF	On/Off	PT100 #1 warning On/Off
		#1 WARNING TEMP 50 °C	50...200	PT100 #1 Warning temperature
		PT100 #2 WARNING OFF	On/Off	PT100 #2 warning On/Off
		#2 WARNING TEMP 50 °C	50...200	PT100 #2 Warning temperature

Table 5.D Cat. No. 825-M... Operating Parameters (Continued)

Group	Required Option Card Cat. No.	LCD	Setting Range	Description
PT 100 (RTD) temperature sensor, continued	825-MMV	PT100 #3 WARNING OFF	On/Off	PT100 #3 warning On/Off
		#3 WARNING TEMP 50 °C	50...200	PT100 #3 Warning temperature
		PT100 #4 WARNING OFF	On/Off	PT100 #4 warning On/Off
		#4 WARNING TEMP 50 °C	50...200	PT100 #4 Warning temperature
		PT100 #5 WARNING OFF	On/Off	PT100 #5 warning On/Off
		#5 WARNING TEMP 50 °C	50...200	PT100 #5 Warning temperature
		PT100 #6 WARNING OFF	On/Off	PT100 #6 warning On/Off
		#6 WARNING TEMP 50 °C	50...200	PT100 #6 Warning temperature
		#1-6 WARNING OFF	AL, #1...#3	PT100, #1...#6 warning Assignment of output relay
		Tamb IN TH IMAGE OFF	On/Off ❶	PT100 #7, allowance for ambient temperature in thermal simulation
		INSULATION CLASS B	B, E, F	Insulation class of winding ❷
Analog output	825-MST	OUTPUT 4...20 mA THERMAL	Thermal utiliz I Motor PT100 max.	Using the analog output for: thermal utilization, motor current, max. PT100 temperature

- ❶ If *Tamb in Thermal Image* is set to "off", the programming menu skips to parameter *Output 4...20 mA*.
- ❷ Limiting winding temperatures of the three insulations classes: E = 120°C, B = 130°C, F = 155°C. When the ambient temperature is taken into consideration, the insulation class needs to be programmed for correction of the thermal model. Without using PT100 #7 as the ambient temperature input, the thermal model bases the thermal calculation on an ambient temperature of 40°C.

Table 5.D Cat. No. 825-M... Operating Parameters (Continued)

Group	Required Option Card Cat. No.	LCD	Setting Range	Description
Communication setting	—	STATION NUMBER 02	0...63 0...63 1...247 1...126	Basic unit station number (DeviceNet) (R I/O) (MODBUS) (PROFIBUS)
	—	BAUD RATE 04	0...2 0...23 0...182 0...4	Baud rate (DeviceNet) (R I/O) (MODBUS) (PROFIBUS)
Relay control	Comm. option, 825-MST	REL #2-3 VIA COM NO	No/Yes ❶	Control of relays #2 and #3 via communication allowed
Clear recorded values	—	CLEAR REC VALUES NOT CLEAR	Not clear/ all clear	Clear/do not clear all recorded values
Reset settings to factory settings (clear recorded values)	—	FACTORY SETTINGS NOT RESET TO	Not reset to/ All reset to ❷	Reset/not reset to factory settings
	—	ARE YOU SURE? NO	No/Yes	Reset/not reset all parameters to factory settings
	—	FACTORY SETTINGS ALL IS RESET TO	—	Confirmation that all parameters are reset to the factory settings
End of setting parameters	—	END SET VALUES	—	End of setting operating parameters

- ❶ If auxiliary relays #2 and #3 are assigned to the communication (refer to page 5-16) they cannot be selected here.
- ❷ If *Factory Settings* is set to "Not Reset To", the programming menu skips to parameter *End Set Value*.

Commissioning and Operation

Checking the Installation

Careful, correct commissioning of the Bulletin 825 Smart Motor Manager is an important prerequisite for reliable protection of the motor and economic operation of the installation. Follow the procedures in this section to ensure that programming and setup are correct.

ATTENTION

Checking and commissioning must be carried out only by qualified personnel. Disconnect the main switch and isolate the control circuit before commissioning or installing the unit.

-
- Current Converter (Cat. No. 825-MCM)
 - Verify that the device's current range lies within the full load or the service current
 - Primary Current Transformer (if used)
 - The transformer rating must be greater or equal to the full load or the service current.
 - The current ratio must be ___ A/1 A or ___ A/5 A for use with Cat. No. 825-MCM2 or 825-MCM20 current converters, respectively
 - Core Balance Current Transformer
 - Verify that the output current of the core balance current transformer is 5...500 mA for the alarm or trip signal.
 - Basic Unit (Cat. No. 825-M...)
 - Verify that the power supply voltage has been properly selected for the control circuit voltage.
 - Verify that the appropriate option cards have been installed.
 - Verify that the indication meter (if required) is connected.

Checking the Wiring

- Primary current transformer, core balance current transformers
- Converter module
- Basic Unit
- Link between basic unit and converter module
- Inputs, outputs
- Supply
- Communication
- Contacts 95...98 are marked according to “electrically held”/“non-fail-safe” connection required.

Checking the Installation with the Control Voltage Applied

Switching on the Control Voltage

After applying control voltage, the current converter is ready for operation in approximately 3 s.

- LCD shows “ACTUAL VALUE”
- Main relay; contact 95/96 is closed

Checking the Set Parameters

Methods

- With the current converter in *Set Values* mode

Access the parameters (or print them out) and compare them with the set values in the list of settings. The main settings are:

- Rated or service current
- Locked-rotor or starting current
- Permissible locked-rotor time

These three settings must be made individually for each motor. Refer to page 5-4, *Operational Parameters*, for procedure.

Motor Current

- Ensure that the current converter's rated current in amperes is equal to the ampere rating on the nameplate of the motor.
 - Set the current converter rated current based on the service current of the motor, if the installation or motor nameplate current is not known.
1. Set the motor current approximately 10...20% higher than the assumed service current.
 2. With the installation running normally, read the motor current on the LCD.
 3. Set the current converter to the service current reading.

EXAMPLE

Set current:	FULL LOAD CURR 140 A
Measured motor current:	I MOTOR 85 % I _e
$\text{Service current} = \frac{\% (I_e) \times I_e}{100} = \frac{85 \times 140 \text{ A}}{100} = 119 \text{ A}$	
Setting to service current ❶:	FULL LOAD CURR 119 A
The motor current is now ❶:	I MOTOR 100 % I _e

❶ In software versions 3.11 and later, the motor current can be displayed in amperes (A) and be set directly.

Locked Rotor or Starting Current

- Set the locked-rotor or starting current as the multiple of rated current $I_A: I_e$ according to specifications given by the manufacturer.
- If no specifications are available, the starting current can either be measured with the current converter or read from Figure 6.1
- The current converter factory setting is $6 \times I_e$.

LCD:

LOCKED ROT CURR
6.00 x Ie

Figure 6.1 Range of Starting Currents of Standard Motors Expressed as Multiple of the Rated Service Current

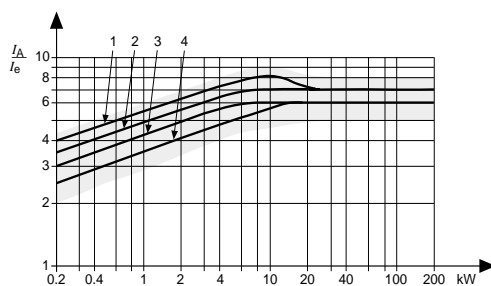

- P_N
- 1 Approximate value for 2-pole motors, speed 3 000 rpm
 - 2 Approximate value for 4-pole motors, speed 1 500 rpm
 - 3 Approximate value for 6-pole motors, speed 1 000 rpm
 - 4 Approximate value for 8-pole motors, speed 750 rpm
- P_N Rated output power in service

Locked Rotor Time

- Normal setting of locked rotor time (i.e., when using standard motors or permissible locked rotor time is known)
- The setting of the locked rotor time must be equal to or less than the value quoted by the manufacturer.
- The current converter factory setting is 10 s. If no application details are available and the starting conditions are normal, leave the setting at 10 s.

LCD:

LOCKED ROT TIME
10 sec

6-5 Commissioning and Operation

- Setting locked rotor time to a minimum level
This procedure enables you to set the locked rotor time to a minimum, so that the motor and installation are better protected.
 - a. Choose a locked rotor time that is less than the probable starting time (e.g., 2 s for thermally rapid underwater motors).
 - b. Start the motor and allow it to cool down after a thermal trip.
 - c. Increase the locked-rotor time until starting succeeds reliably.
- Setting the locked rotor time when the motor starting time is known:

EXAMPLE

Known starting time of the motor is $t_A = 15$ sec.

Locked-rotor time to be set:

approximately $\frac{t_A}{1.4} = \frac{15}{1.4} = 11s$

Setting the locked rotor time with the aid of the indication of thermal utilization

Basic Unit “ACTUAL VALUES” display

LCD:

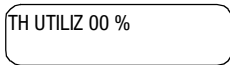

Set the locked rotor time so that the current converter does not trip (< 100%) with the least favorable service load, e.g., at the end of a heavy start. Note that for this procedure, the motor must be of adequate size for the intended application.

Programming, Setup, and Operation

During programming, setup, and operation, the actual operational values can be continuously monitored. To do this, switch the display to “Actual Values” (refer to [Chapter 3](#)).

Starting

LCD	Operation	Description
	Motor start	The motor current, depending on the type of motor, must drop from about 400...800% I_e to the service current of 100% I_e .

Operating

Table 6.A Checking the Actual Values

LCD	Setting Range	Description
ACTUAL VALUES	—	Indication of actual values
I MOTOR...A	0.00...49.99 50...24 000	Motor current in...A
TH UTILIZ...%	0...100	Thermal utilization
I MOTOR...% le	0/20...999	Motor current as a percentage of rated service current (I_{θ})
I 1...% le	0/20...1 200	Motor current I_1 (phase L1), percentage of rated service current (I_{θ})
I 2...% le	0/20...1 200	Motor current I_2 (phase L2), percentage of rated service current (I_{θ})
I 3...% le	0/20...1 200	Motor current I_3 (phase L3), percentage of rated service current (I_{θ})
TRIP IN...sec	1...9 999	Unit will trip in ___s.

Table 6.A Checking the Actual Values (Continued)

LCD	Setting Range	Description
RESET IN...sec	1...9 999	Unit can be reset in ___s
ASYM...%	1...100	Current asymmetry in percent
I earth-H...% I	1...100	Earth (ground) fault current (residual) as percentage of actual service current (I)
I earth-C...mA	5... 999 mA 1.00... 50.00 A	Earth (ground) fault current in mA/A with core balance current transformer
Tambient...°C	0...210	Ambient temperature in °C (PT100, #7)
PT100 #1...°C	0...210	Temperature in °C (PT100, #1)
PT100 #2...°C	0...210	Temperature in °C (PT100, #2)
PT100 #3...°C	0...210	Temperature in °C (PT100, #3)
PT100 #4...°C	0...210	Temperature in °C (PT100, #4)
PT100 #5...°C	0...210	Temperature in °C (PT100, #5)
PT100 #6...°C	0...210	Temperature in °C (PT100, #6)
DevNet : XX : YY : ZZZ	DevNet R I/O MODBUS PROBUS	Display of communication option DeviceNet 825-MDN Remote I/O 3600-RIO Modbus 3600-MBS PROFIBUS 825-MPB
END ACT VALUES	—	End of actual values

Testing and Maintenance

General

The correct functioning of the Smart Motor Manager can be checked by several methods, depending on the requirements:

- With the *Test* button
- With the test condition set
- With a single- or 3-phase current source

A test may be beneficial:

- During commissioning
- Following an interruption in operation
- Following overhauls
- Following reconstruction of the installation

After a test is conducted, the display provides information on the running time of the Smart Motor Manager and the motor, the number of operations performed by the motor, the contactor, etc. From this information, necessary maintenance and installation replacements can be derived.

Checking without Test Equipment

Functional Check with the *Test* Button

With the motor at standstill, the thermal protection, all alarms, trips, and tripping times can be checked with the aid of the *Test* button. Page 3-9 for the specific procedures.

Indication of Recorded Values

All important statistical data can be read on the LCD of the basic unit. Refer to page 3-8 for procedure.

From the recorded values, data can be used to determine:

- Running time of the motor, the Smart Motor Manager, contactor, etc.
- Necessary service jobs
- Operational behavior of motor and installation
- Causes shortly before tripping and the moment of tripping
- Misuse information, such as too many emergency starts, etc.

The table below lists the recorded values accessible from the Smart Motor Manager.

Table 7.A List of Recorded Values

LCD	Description
RECORDED VALUES	Mode: Recorded values
825-M MAIN TIME --- H -- MIN	Total basic unit running time (including interruption of control voltage) in hours, minutes
MOT RUNNING TIME --- H -- MIN	Total motor running time in hours, minutes
SINCE LAST START --- H -- MIN	Time since last start in hours, minutes
SINCE 1 PRV START --- H -- MIN	Time since one start prior to last start in hours, minutes
SINCE 2 PRV START --- H -- MIN	Time since two starts prior to last start in hours, minutes
SINCE 3 PRV START --- H -- MIN	Time since three starts prior to last start in hours, minutes
SINCE 4 PRV START --- H -- MIN	Time since four starts prior to last start in hours, minutes
SINCE LAST TRIP --- H -- MIN	Time since last trip in hours, minutes

Table 7.A List of Recorded Values (Continued)

LCD	Description
SINCE 1 PRV TRIP --- H -- MIN	Time since one trip prior to last trip in hours, minutes
SINCE 2 PRV TRIP --- H -- MIN	Time since two trips prior to last trip in hours, minutes
SINCE 3 PRV TRIP --- H -- MIN	Time since three trips prior to last trip in hours, minutes
SINCE 4 PRV TRIP --- H -- MIN	Time since four trips prior to last trip in hours, minutes
CAUSE LAST TRIP ASYMMETRY TRIP	Cause of last trip, e.g., asymmetry
CAUSE 1 PRV TRIP ASYMMETRY TRIP	Cause of one trip prior to last trip, e.g., asymmetry
CAUSE 2 PRV TRIP OVERCURRENT TRIP	Cause of two trips prior to last trip, e.g., overcurrent
CAUSE 3 PRV TRIP THERMAL TRIP	Cause of three trips prior to last trip, e.g., thermal
CAUSE 4 PRV TRIP PTC TRIP	Cause of four trips prior to last trip, e.g., thermistor
SINCE EMG START --- H -- MIN	Time elapsed since last emergency start in hours, minutes
SINCE POWER OFF --- H -- MIN	Time elapsed since last power failure in hours, minutes
DURATION POW OFF --- H -- MIN	Duration of power failure in hours, minutes
I BEF LAST TRIP --- % IE	Motor current before last trip as a percentage of rated service current (I_e) Short circuit = 999%
AS BEF LAST TRIP --- %	Asymmetry before last trip in percent
EF BEF LAST TRIP --- % I	Earth (ground) fault current before last trip as percentage of rated current or...mA

Table 7.A List of Recorded Values (Continued)

LCD	Description
MAX T BEF L TRIP --- °C	Maximum temperature before last trip in °C (PT100, #1...#6)
TH BEF LAST TRIP --- %	Thermal capacity used before last trip 100% = thermal trip
NUMBER START ---	Total number of motor starts
NUMBER TH TRIP ---	Total number of trips, thermal
NUMBER AS TRIP ---	Total number of trips, asymmetry
NUMBER OC TRIP ---	Total trips overcurrent/locked rotor
NUMBER EF TRIP ---	Total trips, earth (ground) fault
NUMBER SC TRIP ---	Total trips, short-circuit
NUMBER UL TRIP ---	Total trips, underload
NUMBER PTC TRIP ---	Total trips, overtemperature (PTC)
NUMBER PR TRIP ---	Total trips, phase sequence (motor supply)
NUMBER PL TRIP ---	Total trips, phase failure (motor supply)
NUMB PT100 TRIP ---	Total trips, overtemperature (PT100)
TO CLEAR REC VAL GOTO END SET VAL	To clear all recorded values (except running time of basic unit) go to "end set values"
END REC VALUES	End of recorded values

Checking with Test Equipment

A complete check of the Smart Motor Manager's components can be performed with the test unit and a 3-phase current source.

Test Unit

With the test unit, all protective functions set on the Smart Motor Manager can be checked, including the pickup levels and tripping delays.

Test with 3-Phase Current Source

ATTENTION

This test should be performed only by qualified personnel.



Using a 3-phase current source, the main circuit, any primary current transformer, and the current detection module, Cat. No. 825-MCM, can be tested.

Because the functions of the Smart Motor Manager have already been checked with the test unit, it is sufficient to supply a current of $1 \times I_c$ (after approximately 60 min. the thermal utilization reaches 83%). As an alternative, you can measure the 3-phase currents exactly and compare the readings with the values indicated by the LCD on the Smart Motor Manager.

Figure 7.1 Test with a 3-Phase Current Source

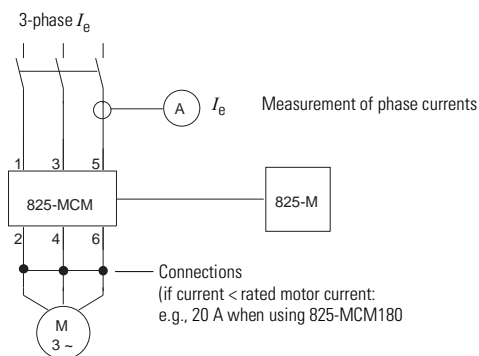

Test with Single-Phase Current Source

ATTENTION

This test should be performed only by qualified personnel.



The test with a 3-phase current source described on page 7-5 can also be performed with a single-phase source. To do this, the earth (ground) fault protection by the Holmgreen method must be switched off.

Figure 7.2 Test with a Single-Phase Current Source

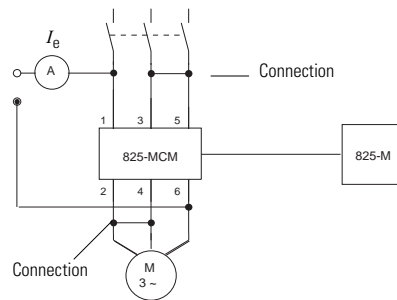

IMPORTANT

The test current may not flow through the core balance current transformer.

Error Diagnosis and Troubleshooting

Alarm, Warning

If an impending defect is detected early enough, motor damage can be minimized. This leads to:

- Lower repair costs
- Less downtime (increased productivity)

Alarm thresholds can be set for:

- Thermal utilization of the motor
- Overcurrent
- Asymmetry
- Underload
- Earth (ground) fault with core balance transformer
- Stator and bearing temperature with PT100

When the alarm threshold is reached, the LED flashes, the LCD indicates the type of alarm, and the selected output relay picks up.

Procedure when Alarm/Warning Picks Up

EXAMPLE

Asymmetry

When an asymmetry condition occurs and the related threshold is reached, the following responses occur:

- LED flashes
- LCD:

AS WARNING

- The assigned output relay picks up

Cause of the warning may be:

- Unbalanced mains
- Defective motor winding
- Defective contacts

Actions

If the installation can be shut down without loss of production or without affecting safety:

- Switch off the installation
- Search for the fault and repair it

If it is important to keep the operation running:

- Continuously monitor the level of *ACTUAL VALUES ASYM...%*
- If the alarm level continues to rise, measures should be taken so that the installation can be shut down quickly.
- If the alarm level remains steady in the region of the set alarm threshold, it is permissible to wait until the next planned interruption in operation to locate and repair the fault.

ATTENTION

While the alarm is on (red LED flashing), the alarm function cannot be disabled (refer to page 8-8).



Trip

EXAMPLE

Asymmetry

Faults in the motor or the installation can develop and lead to the set threshold being rapidly exceeded. When this occurs and the related threshold is reached, the following responses occur:

- LED lights
- LCD:

ASYMMETRY TRIP

- The assigned output relay picks up

Actions

Determine the trip cause and correct the problem before re-starting the motor installation.

ATTENTION

While the trip is on (red LED on), the protection function cannot be disabled (refer to page 8-8).

**Fault Codes****Table 8.A Possible Causes and Actions**

LCD	Designation	Possible Causes	Actions
	No indication	No supply voltage	Ensure power supply is on. Check the supply.
		Wrong supply module in basic unit	Insert correct supply module. If the voltage applied to the supply module was too high, it and the functions of the unit must be tested.
		Basic unit defective	If no fault is found or if in doubt, send the unit back to the factory for repair.
		Thermal trip of supply module <ul style="list-style-type: none"> • Supply voltage too high • Ambient temp. too high • Current consumption too high • Supply module failed 	Switch off control supply. Restore normal conditions and let the unit cool down for approx. 30 min. Send the unit back to the factory for repair.
	V2.17 and later: No indication, red LED on	Watch Dog Microprocessor failure	Send the basic unit back to the factory for repair.
DEFECT #1	Real time clock fault	RTC defective	Send the basic unit back to the factory for repair.
DEFECT #2	μP fault (RAM)	Microprocessor RAM defective	Send the basic unit back to the factory for repair.
825-MCM NOT CON	Open circuit basic unit to converter module	Cable from basic unit to converter module not connected or broken	Check connections. Test cable (open/short-circuit). Replace cable if necessary.

Table 8.A Possible Causes and Actions (Continued)

LCD	Designation	Possible Causes	Actions
825-MCM ERROR	Converter module cannot be correctly recognized	Link between basic unit and converter module defective	Check link between basic unit and converter module and replace if necessary. Switch supply off and on again
		Fault in basic unit	If the fault cannot be remedied, send the unit back to the factory for repair.
IE OUT OF RANGE	Rated current and setting do not agree	Converter module rated current does not agree with basic unit setting	Check setting "FULL LOAD CURR" and converter module.
		Wrong converter module	Install the correct converter module
		Wrong setting	Press "Values" until "SET Values" on LCD, correct "FULL LOAD CURR" (within about 5 s)
ERROR ACT VALUES	Error in actual values	Data could not be saved when supply last interrupted	Press Reset. Check power supply. If the fault repeatedly occurs, send the unit back to the factory for repair.
ERROR REC VALUES	—	Hardware fault	Send the basic unit back to the factory for repair.
THERMAL WARNING	Thermal warning	Overloaded	Reduce load.
		Transported material jammed	Switch off installation, remedy trouble.
THERMAL TRIP	Thermal trip	Mechanical damage, bearings, etc.	Repair the damage.
		Settings of rated current or tripping time too low	Raise "FULL LOAD CURR"/"LOCKED ROT TIME" to permissible motor values.
		Interrupted start: motor inadequately cooled	Wait until motor has cooled down. (LCD: TH UTIL...% appr. 20%)
		More than one warm start/hour	If permissible, increase number of warm starts/h.
		Ambient temperature too high (Function PT100, #7 ON)	If possible, reduce load.
		Very high third harmonic (e.g., star-delta connection)	Raise I_e setting accordingly.
		Cooling constant ratio has been changed	Check and reset to correct setting (factory setting 2.5).

Table 8.A Possible Causes and Actions (Continued)

LCD	Designation	Possible Causes	Actions
ERROR SET VALUES	—	Setting of locked rotor current and/or locked rotor time are outside the permissible range	Press "Values" until "SET VALUES" on LCD. Set "LOCKED ROT CURR" to $6 \times I_e$. Set "LOCKED ROT TIME" to 10 s. Set "LOCKED ROT CURR" and "LOCKED ROT TIME" correctly within permissible range (refer to Chapter. 3).
AS WARNING	Asymmetry warning	Mains unbalanced	If asymmetry inadmissibly high, clarify cause with electric company. If asymmetry has values usual for the area, raise threshold in the basic unit.
ASYMMETRY TRIP	Asymmetry trip	Blown fuse <ul style="list-style-type: none"> • Short-circuit/Earth (ground) fault • Failure during starting 	<ul style="list-style-type: none"> • Repair the trouble, replace the fuse. • Redimension fuse (note short-circuit coordination).
		Motors idling (e.g., pumps)	Raise threshold in basic unit to permissible level.
		Poor contacts (terminals, contactor, breaker, etc.)	Repair trouble.
		Phase lead broken (motor lead, link between basic unit and converter module)	Replace or repair cable.
		Asymmetrical motor winding	If asymmetry is acceptable, raise threshold in basic unit; otherwise repair motor.
		Main current transformer error <ul style="list-style-type: none"> • Metering class current transformer instead of protection current transformer • Wrong current range • Current transformer rating too low • Incorrect current transformer wiring 	<ul style="list-style-type: none"> • Insert the correct current transformer. • Replace the current transformer. • Replace the current transformer. • Check and correct wiring.
OC WARNING	Overcurrent warning	Overload	Reduce load or raise pickup threshold.
		Transported material jammed	Switch off installation, remedy cause.
		Pickup threshold set too low	Raise pickup threshold.
OVERCURRENT TRIP	Overcurrent trip	Mechanical damage to bearings and transmission system	Repair the damage.
		Stalling during start (causes as for jamming when running)	Switch off installation, remedy cause.

Table 8.A Possible Causes and Actions (Continued)

LCD	Designation	Possible Causes	Actions
EF HOLMG TRIP	Earth (ground) fault (Holmgreen/residual) trip	Earth (ground) fault motor winding or cable Trip when running: <ul style="list-style-type: none"> • Primary current transformer wrongly wired • Primary current transformer saturated • High proportion of third harmonic in star-delta 	Repair damage. <ul style="list-style-type: none"> • Correct wiring. • Raise pickup threshold. • Raise pickup threshold to 50% or more.
EF C WARNING	Earth (ground) fault warning with core balance transformer	Trip during start: Primary and core balance transformer wired incorrectly	Correct the wiring (core balance transformer may only surround the three motor leads).
EF CORE TRIP	Earth (ground) fault trip with core balance transformer	Long motor cable Earth (ground) fault in motor winding or cable due to: <ul style="list-style-type: none"> • Moisture • Dirt • Mechanical damage 	Raise pickup threshold. Eliminate cause.
SHORT CIRC PROT	Short-circuit trip	Short-circuit or earth (ground) fault in motor winding or cable Trip when motor is switched on, due to inrush current Pickup threshold is $< I_A$	Repair damage. Increase trip delay to > 0.1 s. Set pickup threshold to $> I_A$.
UL WARNING	Underload warning	Underwater pump running dry Faulty fan blades	Eliminate cause, lower pickup threshold if necessary or increase trip delay. If tripping takes place too soon after starting, increase the start delay.
UNDERLOAD TRIP	Underload trip	Torn conveyor belt Broken transmission elements Pumping against a closed valve Current setting I_0 too high	Eliminate cause. Set correct value.
START INHIB TRIP	Max. number of starts/h reached	Maximum number of starts has been exceeded.	Wait until another start is permissible. Release will be automatic. If another start is permissible, increase number of start/hour by "1" and start again.
START CONT TRIP	Start in max. starting time not possible	Overloaded Transport material jammed Viscous material	Reduce load or raise max. starting time to permissible value. Eliminate cause. Raise max. starting time to permissible value.

Table 8.A Possible Causes and Actions (Continued)

LCD	Designation	Possible Causes	Actions
PTC TRIP	PTC trip	PTC or PTC leads short-circuited or broken	Check leads, remove fault. PTC: Motor for repair. If not possible, switch off PTC monitoring "PTC PROT/OFF".
		Stator winding overheated by: <ul style="list-style-type: none"> • Overload • Too many starts/hour • Too many warm starts/hour • Obstructed cooling • High ambient temperature 	Wait until motor has cooled down sufficiently for a reset. <ul style="list-style-type: none"> • Search for cause and eliminate. • Reduce starts/hour. • Reduce number of warm starts/hour. • Clean motor and cooling air intake. • Protect against heat; reduce load or switch off installation.
PHASE REVER TRIP	Phase sequence protection (motor supply)	Wrong phase sequence of supply to converter module	Connect phase leads in correct sequence.
PHASE LOSS TRIP	Phase failure trip (based on motor supply)	Faulty fuse: Short-circuit/earth (ground) fault	Remedy damage, replace the fuse.
		Failure during start	Redimension fuse (noting short-circuit coordination).
		Broken lead	Check cables and terminal connections.
PT100 #...WARNING	PT100 #1...#6 (RTD) temperature warning	Stator winding overheated by: <ul style="list-style-type: none"> • Overload • Too many starts/hour • Too many warm starts/hour • Obstructed cooling 	Wait until motor has cooled down sufficiently to permit reset. <ul style="list-style-type: none"> • Search for cause and remedy. • Reduce start/hour • Reduce warm starts/hour • Clean motor and cooling air intake.
PT100 #...TRIP	PT100 #1...#6 (RTD) temperature trip	<ul style="list-style-type: none"> • High ambient temperature 	<ul style="list-style-type: none"> • Protect against heat. Reduce load or shut down the installation, and wait until motor has cooled down sufficiently for a restart.
PT100 SHORT CIRC	PT100 (RTD) has been short- or open-circuited.	Failure in PT100 (RTD) circuit	Check cables, terminal connection and PT100 (RTD) sensor
PT100 NO CONNECT	This message may appear together with a PT100 #1...#6 (RTD) TRIP		

Procedure if "ALARM" does not Reset

Indication

- LCD: Does not display the type of the alarm (LCD active)
- Red LED: Flashing

Cause for this Condition

If the affected alarm function is switched "OFF" before the alarm has disappeared or the motor has been switched off, then the alarm stays on whether the motor is switched on or off.

How to Get Rid of Alarm

- Go to *SET VALUES* mode.
- Switch on all alarm functions (e.g., "THERMAL WARNING" "ON").
- As soon as the affected alarm function is switched on again, then the alarm condition will disappear.
- Switch alarm function off if not required

Procedure if "TRIP" cannot be Reset

There are two reasons why a trip can not be reset if the motor is not running.

Thermal Trip

Indication

- LCD: "THERMAL TRIP"
- Red LED: On

How to Reset

The motor must have cooled down to the pre-set level, before the reset is possible:

"TH RESET LEVEL" setting range 10...100%, factory setting 50%.

Other Trips

Indication

- LCD: Does not display the type of the trip (LCD active)
- Red LED: ON

Cause for this Condition:

If the tripped protection function has been switched “OFF”, before the trip has been reset, then the trip can not be reset the normal way.

How to Reset

- Go to *RECORDED VALUES* mode
- Go to “CAUSE LAST TRIP” e.g., “ASYMMETRY TRIP”
- Go to *SET VALUES* mode
- Go to tripped Protection Function e.g., “ASYMMETRY TRIP”
- Switch Protection Function on e.g., “ASYMMETRY TRIP” “ON”
- Reset Trip: Red LED goes off
- Switch Protection Function off, if not required

Applications/Wiring

Bulletin 825 Smart Motor Manager with Contactors

ATTENTION

Strictly observe the installation instructions and the specifications for the contactors, auxiliary relays, etc.



Main Circuit

Figure 9.1 Basic Unit and Converter Module

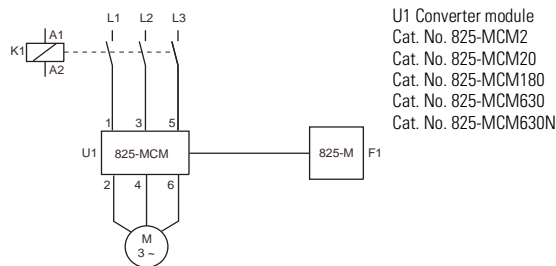

Control Circuit

Figure 9.2 Control by Momentary Contact

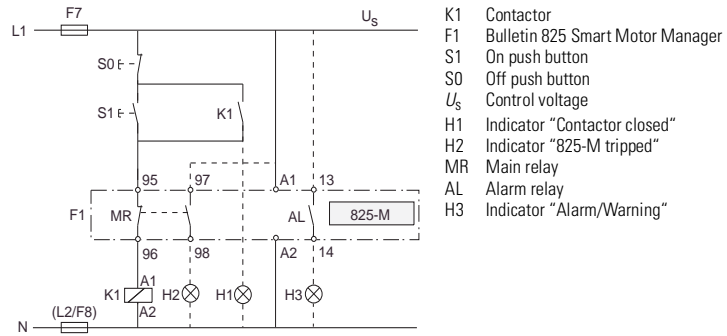

ATTENTION



The mounting/wiring directions and the specifications of the contactor being used must be considered.

Star-Delta Starter with Bulletin 825 Smart Motor Manager

Main Circuit

Figure 9.3 Basic Unit and Converter Module

Basic Unit settings:

- FULL LOAD CURR $FLC \times 0.5774 [A]$
- LOCKED ROT CURR $I_{BL\Delta} (... \times I_e)$
- LOCKED ROT TIME $t_{BL\Delta} (...sec.)$
- START TIME $> t_{startY} (...sec.)$

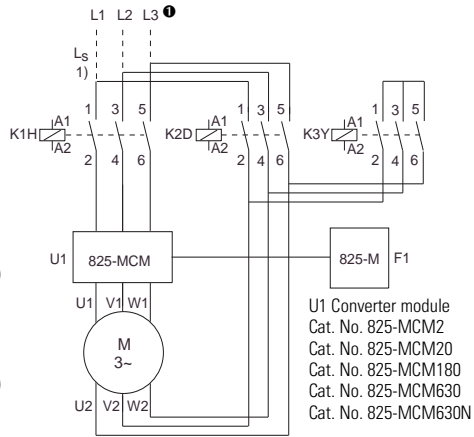

① Core balance installation position

Control Circuit

Figure 9.4 Control by Momentary Contact

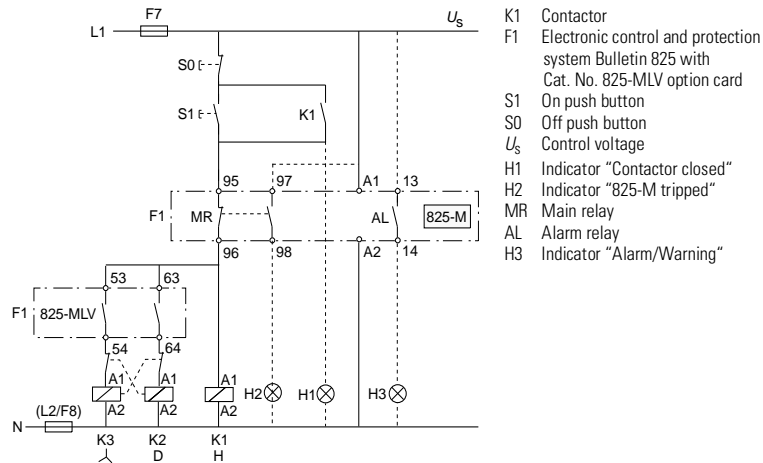

- K1 Contactor
- F1 Electronic control and protection system Bulletin 825 with Cat. No. 825-MLV option card
- S1 On push button
- S0 Off push button
- U_s Control voltage
- H1 Indicator "Contactor closed"
- H2 Indicator "825-M tripped"
- MR Main relay
- AL Alarm relay
- H3 Indicator "Alarm/Warning"

Short-Circuit Protection of Medium/High-Voltage Motors

Main Circuit (with Cat. No. 825-MST Option Card)

3-Phase Current Evaluation

Figure 9.5 Basic Unit for Short-Circuit Protection

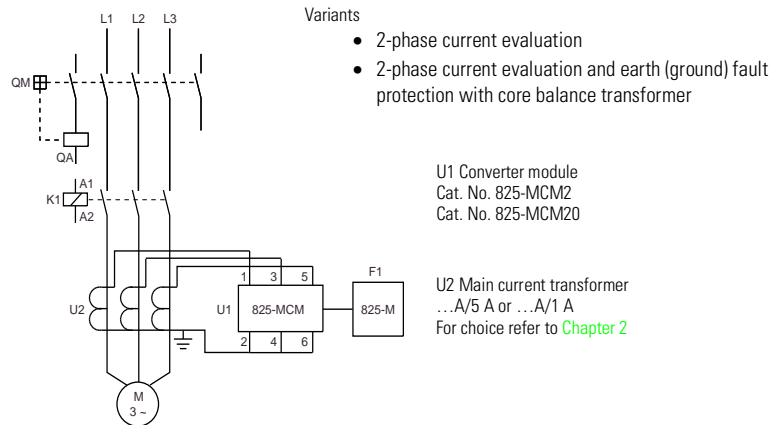

Control Circuit

Figure 9.6 Control by Momentary Contact

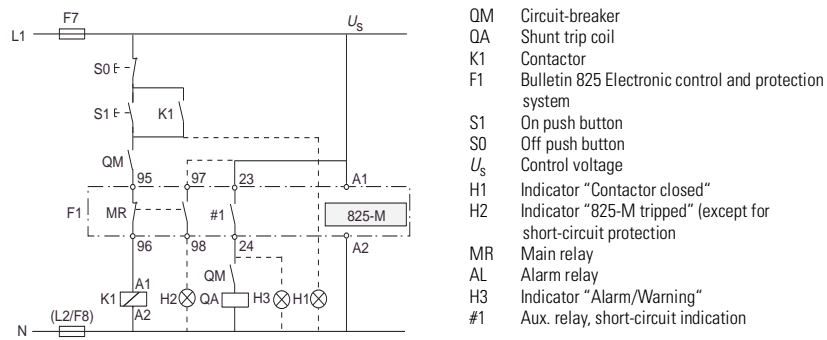

Two-Speed Motors

The following ranges are possible for speeds I and II:

Speed I-II	Converter Module
0.5...2.5 A	with 825-MCM2
2.5...20 A	with 825-MCM20
20...180 A	with 825-MCM180
160...630 A	with 825-MCM630 or 825-MCM630N

Main Circuit

Figure 9.7 Two-Speed Application Utilizing One 825-MCM*

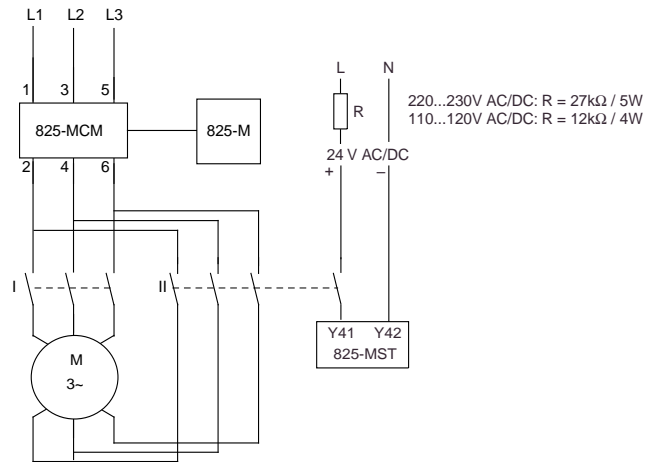

For setting the second current (speed II), refer to [Chapter 5](#), “Control input #2”.

Two-Speed Motor: $0.5 \text{ A} < \text{Speed I} < 20 \text{ A} < \text{Speed II} < 180 \text{ A}$

Main Circuit

Figure 9.8 Two-Speed Application Utilizing 825-MCM180

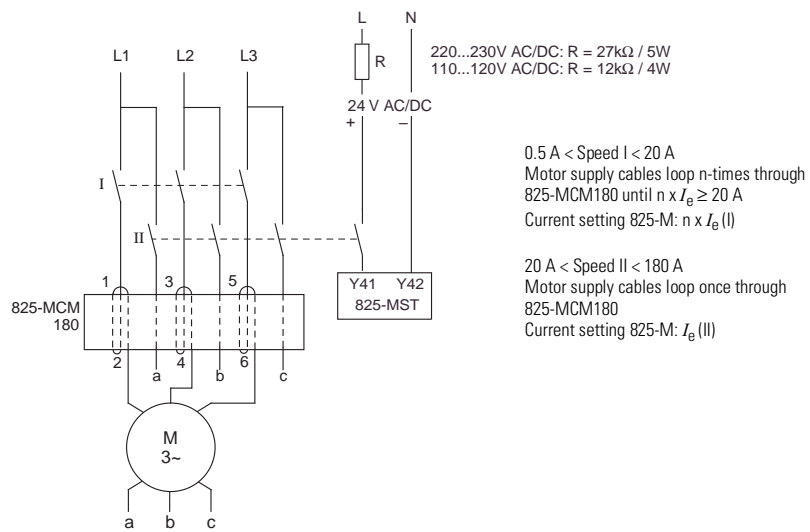

For setting the second rated current (speed II), refer to [Chapter 5](#), “Control input #2”.

Two-Speed Motors with Primary Current Transformer

When a primary current transformer is used, two-speed motors of any rating can be protected.

Primary Circuit

Figure 9.9 Two-Speed Application Utilizing Primary Current Transformer

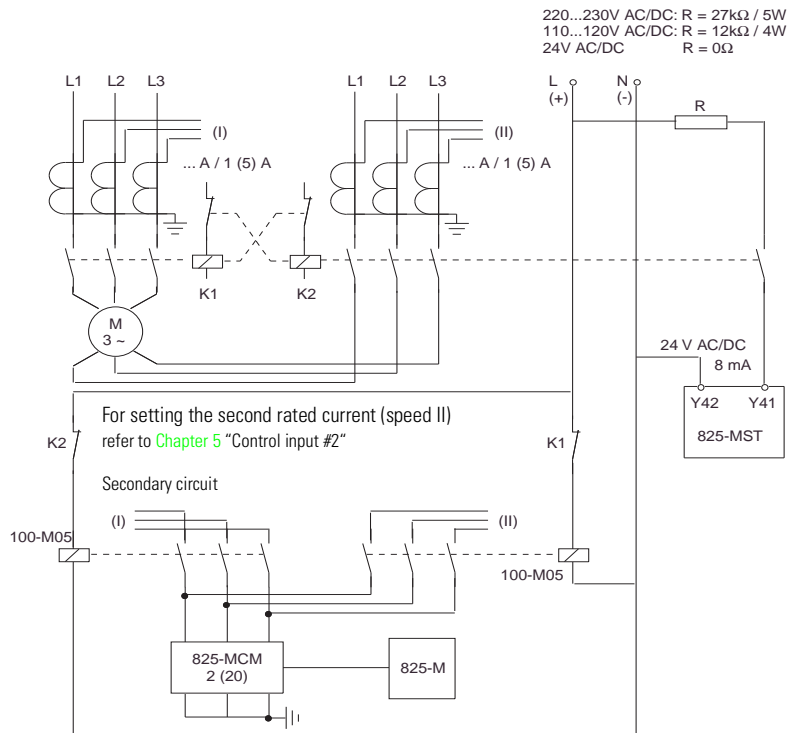

Separately Ventilated Motors

Because they are cooled constantly, separately ventilated motors exhibit the same thermal behavior when stationary as when running. Consequently, the cooling ratio must be set to 1.

LCD:

COOL-CONST RATIO
1.00

For setting the cooling ratio, refer to [Chapter 5](#).

Basic Unit and Converter Module with Primary Current Transformer and Core Balance Current Transformer

Main Circuit

Figure 9.10 Typical Application Utilizing Primary Current Transformers and Core Balance Current Transformer

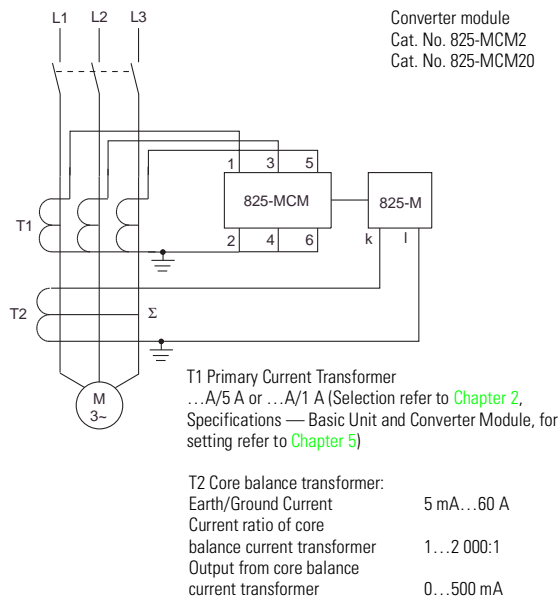

Basic Unit and Converter Module with Core Balance Current Transformer

Main Circuit

Figure 9.11 Typical Application Utilizing Core Balance Current Transformer

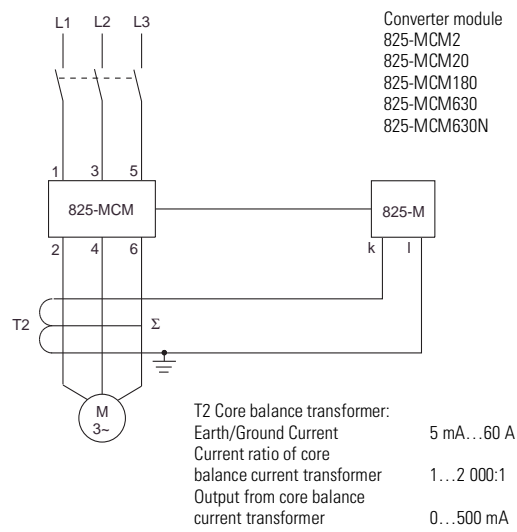

Motors with Low Idling Current (< 20% I_e)

Main Circuit

Figure 9.12 Application with Low Idling Current

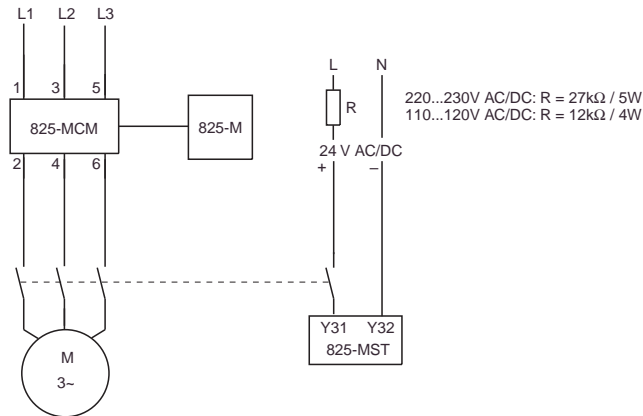

Settings	Display
CONTROL INPUT #1 ON	MOTOR < 20 % IE
SPEED SWITCH ON	<ul style="list-style-type: none"> Motor switched on Motor current < 20% I_e

If motors have an operational idling current of less than 20% I_e , then the information “motor switched on” must be fed with an auxiliary contact of the contactor into control input #1.

Connecting the PT100 Temperature Sensors Using the 2/3/4-Conductor Technique

The Bulletin 825-MMV Option Card has been designed for the 3-conductor technique. Given the diameter of the conductor, it is also possible to connect the PT100 temperature sensors by using the 2/4-conductor technique.

Figure 9.13 2/3/4 Conductor Technique for PT100 Wiring

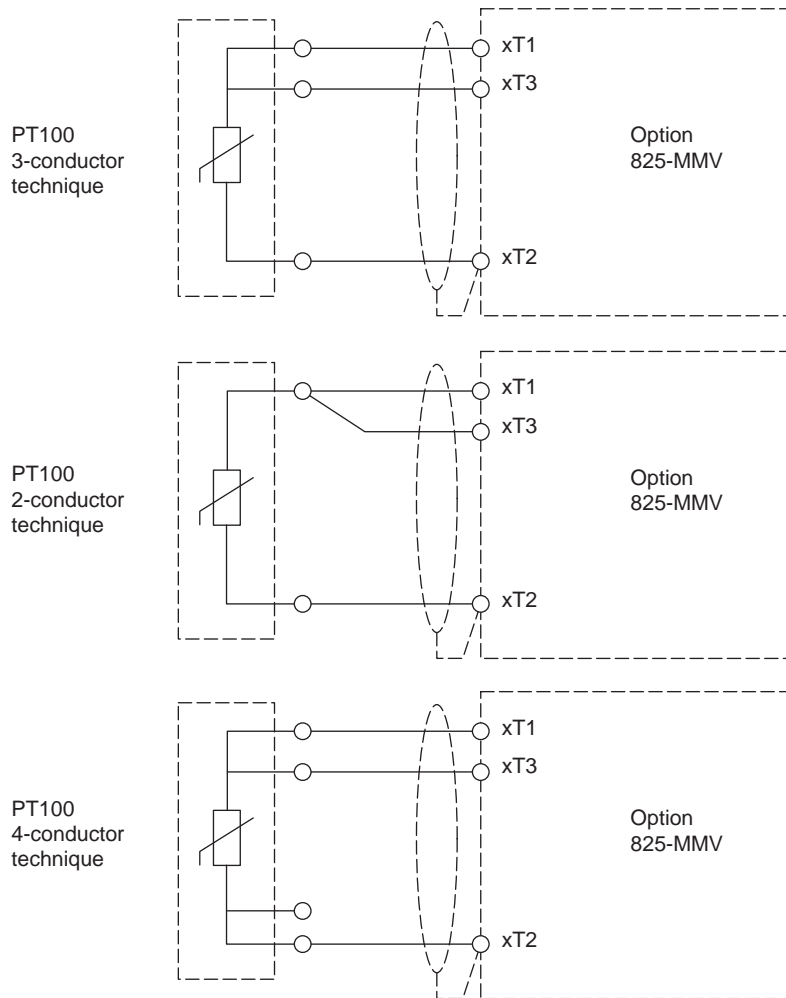

Basic Unit and Converter Module with Primary Current Transformer, 2-Phase Current Evaluation

Figure 9.14 Typical Application Utilizing 2-Phase Current Evaluation with Primary Current Transformers

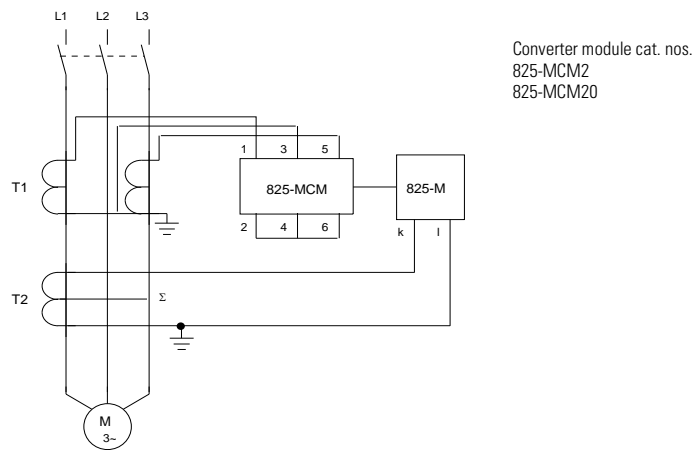

Time/Current Characteristic of Bulletin 825 Smart Motor Manager

Figure 9.15 Trip Characteristics

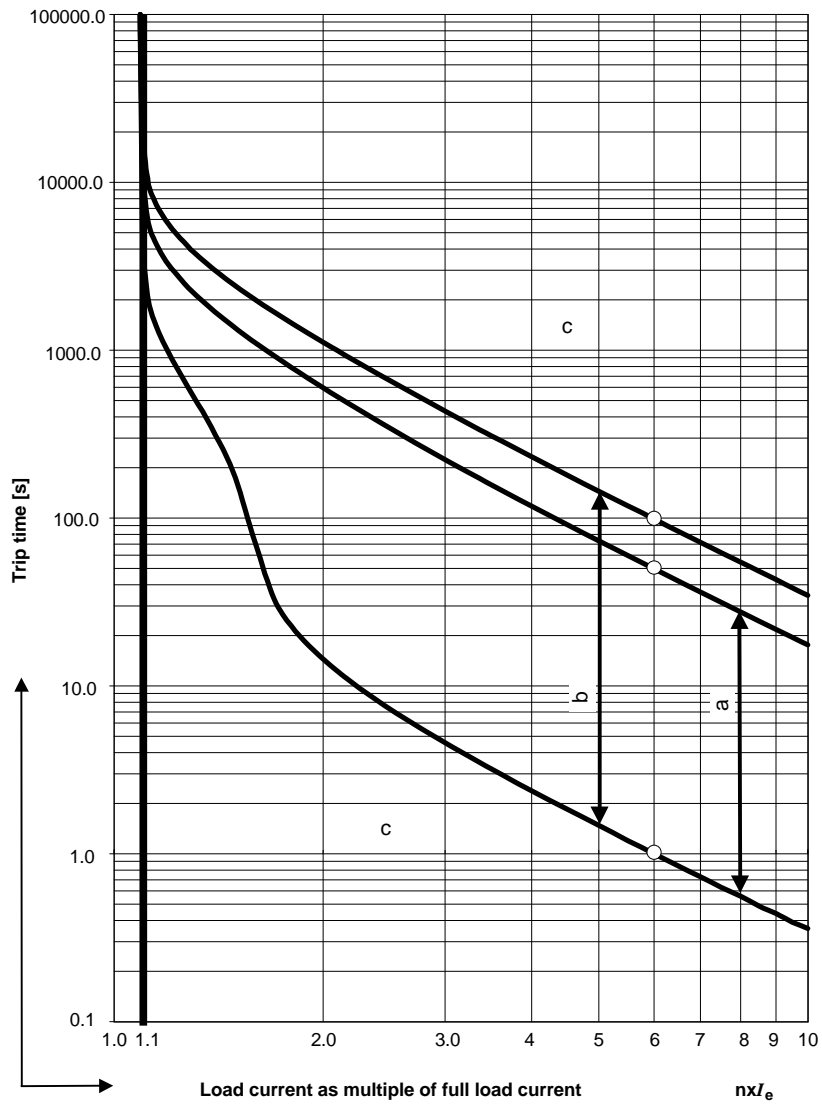

a: Setting range for UL/CSA applications

b: Setting range for IEC applications

c: The setting of I_A/t_{IA} must be outside the range "c" (e.g., when $I_A = 6 \times I_e$, t_{IA} must be ≤ 100 s and ≥ 1 s).

References

- A. Rotary Crusher Application Profile (Publication 0825-1.3EN)
- B. Waste Water Application Profile (Publication 0825-1.4EN)
- C. Multifunctional Motor Management (Publication 825-BR001B-EN-P)
- D. Smart Motor Manager Relay Selection Guide (Publication 825-CA001A-EN-P)
- E. Smart Motor Manager Hot Topics (Publication 0825-9.0)
- F. Smart Motor Manager User Manual (Publication 0825-5.0)
- G. DeviceNet™ Communication Card User Manual (Publication 0825-5.4)

Notes:

Notes:

www.rockwellautomation.com

Power, Control and Information Solutions Headquarters

Americas: Rockwell Automation, 1201 South Second Street, Milwaukee, WI 53204-2496 USA, Tel: (1) 414.382.2000, Fax: (1) 414.382.4444
Europe/Middle East/Africa: Rockwell Automation, Vorstlaan/Boulevard du Souverain 36, 1170 Brussels, Belgium, Tel: (32) 2 663 0600, Fax: (32) 2 663 0640
Asia Pacific: Rockwell Automation, Level 14, Core F, Cyberport 3, 100 Cyberport Road, Hong Kong, Tel: (852) 2887 4788, Fax: (852) 2508 1846

Publication 825-UM001B-EN-P January 2001

Supersedes Publication 825-5.0EN dated June 1998

© 2001 Rockwell International Corporation. Printed in the U.S.A.

Software Version 3.15

PN 40055-158-01(B)

Supersedes PN 40055-158-01(A)