

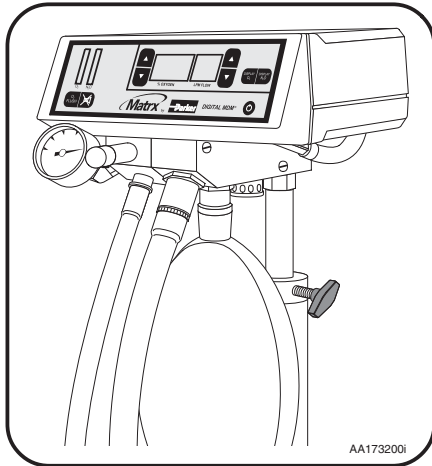

Parker Hannifin Corporation
Porter Instrument Division
245 Township Line Road
Hatfield, PA 19440
Office 215 723 4000
Fax 215 723 5106



Digital MDM Operations Manual



This product complies with the Medical Device Directive (93 / 42 / EEC).
A "Declaration of Conformity" in accordance with the directive has been made and is on file.



European Communities should contact the Authorized Representative listed below regarding any Medical Device Directive (MDD) inquiries.

Contact Name: Parker Hannifin Ltd Instrumentation Products Division
Mailing Address: Riverside Road, Pottington Business Park
Barnstaple, EX 31 1NP, England
Phone: +44 (0) 1271-313131 Fax: +44 (0) 1271-373636

The Quality System for Porter Instrument is certified to ISO 13485. The scope of our registration is:
"The design, manufacture, distribution and servicing of Nitrous Oxide – Oxygen Sedation Flowmeters, Gas Scavenging Systems, Gas Distribution Systems and Office Communication Systems for use by a physician, dentist or licensed healthcare Profession."

Check our website: www.porterinstrument.com for additional information.
To register your product: www.porterinstrument.com/resources-dental choose Warranty tab.
To download a User's Manual: www.porterinstrument.com/resources-dental choose Manuals tab

IMPORTANT:

READ MANUAL COMPLETELY Before Operating This Device

Basic delivery technique is described. Also, this manual contains instructions on periodically required checks to be performed by the user. These checks are necessary to insure the proper performance of this device and its safety features. Retain this manual for future reference.



WARNINGS AND PRECAUTIONS

These warnings and precautions are to help you to understand how to safely operate the MXR Flowmeter. A WARNING alerts you to a possible hazard to people. A CAUTION alerts you to the possibility of equipment damage.

WARNING: Do not use this device for the administration of general anesthesia or as a part of, or in conjunction with, a general anesthesia administration system.

WARNING: Workers are exposed to N₂O during administration of N₂O/O₂ conscious sedation analgesia. NIOSH has recommended that exposures should be minimized. Contact NIOSH (1-800-35-NIOSH) to receive NIOSH Publications on *Control of Nitrous Oxide in Dental Operatories*. Exposure can be minimized by effective controls. National Institute for Occupational Safety and Health (NIOSH) publications state that controls, including System Maintenance, Ventilation and Work Practices can effectively reduce N₂O concentrations in patient procedures. Your flowmeter accessory Porter scavenger system is an important part of the system of controls.

WARNING: Porter Instrument equipment utilizes the **cross+protection** system. The flexible hose and connectors that connect to the flowmeter are diameter indexed; 3/8" O.D. for Nitrous Oxide and 1/2" for Oxygen. The **cross+protection** system is designed to prevent misconnection of Oxygen and Nitrous Oxide piping. **DO NOT ATTEMPT TO CHANGE THE DIAMETERS OR CONNECTORS OF THE FLOWMETER!** Tampering with the **cross+protection** system constitutes acceptance of liability by the installer. For your own protection, as well as that of the Doctor and the patients, use 3/8" O.D. tubing for all Nitrous Oxide lines and 1/2" O.D. tubing for all Oxygen lines.

To assure safe operation and conformation to local fire codes, all Porter Instrument flowmeter systems are designed to be used with sedation delivery systems mounted inside walls and they meet or exceed the

guidelines established by the National Fire Protection Association for Nonflammable Medical Gas Systems, NFPA 99. Copies of NFPA 99 or portions thereof may be obtained by writing to: National Fire Protection Association, Batterymarch Park, Quincy, MA 02269-9904; or call 1-800-344-3555

WARNING: New or modified installations - **properly connected gas pipelines are absolutely essential to patient safety.** The authorized distributor or contractor should provide written documentation that all gas pipelines are connected properly and that the system has been pressure tested prior to use. While this is a good business practice, it is important that the user verify by their own test, independent of the authorized distributor or contractor, that all gas pipelines are connected correctly prior to using the system. **The ultimate responsibility of assuring that lines are not crossed rests with the user.**





WARNING: During any power outage, remember to turn OFF the flowmeter and manually turn OFF the tank valves. With centralized, electrically powered gas systems, if gas was flowing when the power went out and the flowmeter is left ON, gas will be flowing when the power is restored.

CAUTION: This device is for use by or on the order of a physician, dentist or licensed healthcare professional.

CAUTION: Always use clean, dry medical grade gases. Introduction of moisture or other contaminants into this device may result in defective operation.

CAUTION: Do not attempt to repair, alter or calibrate this device. Unauthorized repair, alteration or misuse of this device is likely to adversely affect the performance and will void the warranty.

CAUTION: Never oil or grease any part of this system (minimize fire or explosion potential).

Symbol	Description
	MEDICAL EQUIPMENT WITH RESPECT TO ELECTRIC SHOCK, FIRE AND MECHANICAL HAZARDS IN ACCORDANCE WITH UL 2601-1, AND CAN/CSA C22.2 NO. 601.1
	Alternating Current
	Earth (ground)
	Attention, consult the accompanying documents
	Type B Equipment

WARNINGS and PRECAUTIONS

ELECTRICAL CONNECTIONS

Do not use an electrical cord with nicks, cuts, or other damage. Do not use the unit with an extension cord as it will be subject to electromagnetic interference (EMI).



BAG TEE REQUIREMENTS

A bag tee containing an air inlet valve is required for use with this unit. The bag tee is factory mounted on the unit or provided separately for remote mounting. Matrx by Parker Scavenging Nasal Inhalers provide the patient connection.

FACILITY PIPING

The user **MUST** perform tests independent of the dealer or contractor to verify that all pipelines are connected correctly. If you are unfamiliar with piping systems, order Matrx manual 10311700. The user has the ultimate responsibility for properly connected pipelines essential to patient safety.

DIAMETER INDEXED SAFETY SYSTEM

Gas connections in the DIGITAL MDM mixer are mechanically indexed using the Diameter Indexed Safety System (DISS). This feature helps to prevent the crossing of pipelines. Under no circumstances should these connections be altered.

DISCONNECT POWER

There are no user-serviceable parts inside this unit. A shock hazard exists if power is not disconnected prior to any internal servicing or maintenance. Always disconnect the power source before inspection or repair.



ALARM TEST

The user should test the alarm system for proper operation prior to each clinical use.

INTENDED USE: FLOWMETER FOR ANALGESIA DELIVERY SYSTEM

This device is intended for patient use by an attending physician, dentist or licensed professional properly trained in its use. Porter Instrument recommends the user be thoroughly familiar with the use of Nitrous Oxide - Oxygen Conscious Sedation for patient analgesia and be properly trained in its administration prior to using this product. For training requirements on the administration of Nitrous Oxide - Oxygen Conscious Sedation, contact the appropriate regulatory authority in your country, state, or province. Training is recommended to provide a practical, hands-on capability and an understanding of the behavioral aspects of Nitrous Oxide Sedation and will complement the safety features of this device. The devices permit the operator to adjust the percent of oxygen through a range of 100% to 30% (and thereby control the ratio of oxygen to nitrous oxide). The operator can also control the total volume of mixed gas up to 9.9 liters per minute.

Use Scavenging

Monitor for N₂O in the patient treatment area to insure that controls are effective in achieving low levels of PPM (parts per million) exposure. Contact your Porter dealer for details on monitors and testing.

Gas Supply Connection

After installation of the flowmeter, connect the nitrous oxide and oxide supply lines to the Diameter Indexed Safety System (DISS) fittings located on the back of the flowmeter unit. It is important that the regulators for both gases be set to give pressures in the range of 53 PSIG \pm 2 PSIG. Confirm the absence of leaks at pressure connections on the unit. Bubbles will appear at leaking locations when a soap / water solution is used. This procedure is recommended each time a cylinder is changed. Refer to FM-916 Mobile "E" Tank Stand Installation and Instructions for connecting gas supply to the flowmeter and tank installation to mobile stand.

User Responsibility

This product should not be repaired other than in accordance with written instructions provided by Matrx by Parker. The user of this product shall have the sole responsibility for any malfunction which results from improper use, faulty maintenance, improper repair, damage, or alteration by anyone other than Matrx by Parker. It is the user's responsibility to ensure that the correct gas, at the correct pressure, is supplied to the fittings at the rear of the unit.

Machine Diagnostics

The DIGITAL MDM mixer performs self checks at start up and during operation. If any errors are detected, the unit displays EE on the %O₂ display and an error code on the FLOW display. If an error code appears, remove the unit from patient service and call the Matrx by Parker Technical Service Department at 1-888-723-4001. To aid in the diagnostics of the unit, make note of the final error code displayed.

Description of Unit: The DIGITAL MDM® mixer is shown in Figure 1. The device permits the operator to adjust the percent of oxygen through a range of 100% to 30% (and thereby control the ratio of oxygen to nitrous oxide). The operator can also control the total volume of mixed gas up to 9.9 liters per minute.

Mixture Control: The DIGITAL MDM mixer precisely mixes oxygen and nitrous oxide from local cylinders or pipeline gas systems, and delivers the electronically controlled mixture to the bag tee outlet.

Built-In Safety: A series of alarms (see Safety Alarm System page 5) alert the user to any problem condition within the DIGITAL MDM mixer unit or in the gas supply.

Displays and Indicators: In the following, the location numbers refer to Figure 1.

Flow Display: The LPM FLOW display (4) normally displays the total gas flow rate. It also displays the individual nitrous oxide or oxygen flow rates when either the N₂O or O₂ flow display controls (6) are pressed. The gas flow being displayed is indicated in the flow indicator (5) by O₂, TOTAL or N₂O.

% OXYGEN Display: The % OXYGEN display (3) indicates the oxygen concentration set point in the total flow.

Gas Flow Indicators: Gas flow is indicated by bar graph LEDs (1). A green bar graph represents O₂ while blue represents the N₂O flow. The number of lit bars gives a graphical indication of the flow level of a particular gas.

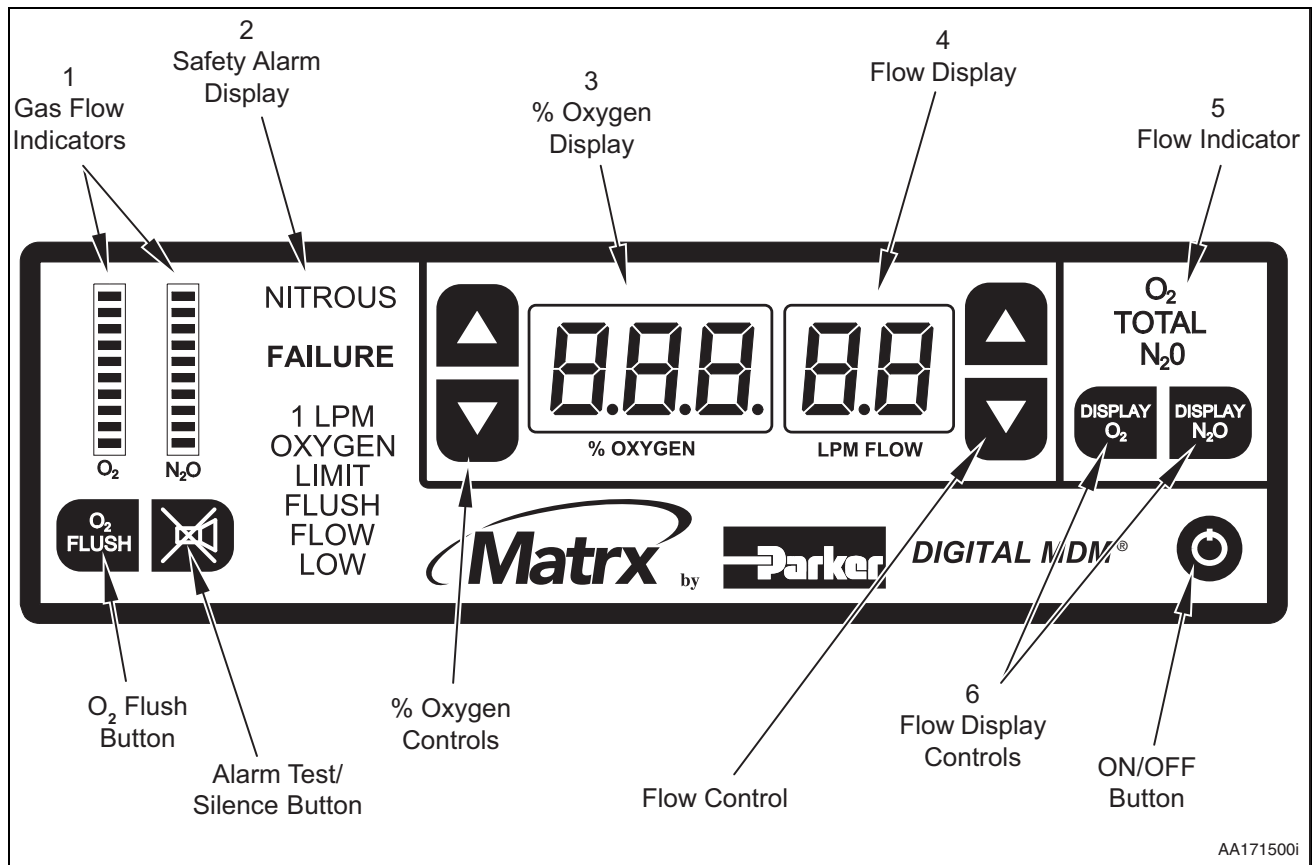

Figure 1. Matrix DIGITAL MDM® Mixer Front Panel (figure shows all LEDs illuminated)

Safety Alarm System

There are four alarm conditions on the DIGITAL MDM® mixer. They appear in the safety alarm display (see Figure 1, item 2) only when conditions warrant. Otherwise, they are not visible. The alarm conditions are:

OXYGEN FAILURE: This alarm indicates that the set oxygen (O₂) flow cannot be delivered. Check the oxygen supply. During an OXYGEN FAILURE alarm, the nitrous oxide delivery is automatically shut off. The LPM FLOW and % OXYGEN displays are off.

NITROUS FAILURE: This alarm indicates that the set nitrous oxide (N₂O) flow cannot be delivered. Check the nitrous oxide supply. During a NITROUS FAILURE alarm, the LPM FLOW display indicates oxygen flow and the % OXYGEN display is off.

Both the OXYGEN FAILURE and NITROUS FAILURE are self-canceling alarms. When the gas is restored, the unit returns to the flow rate and mixture ratio which were in effect before the alarm condition.

1 LPM OXYGEN LIMIT: This message is displayed when the oxygen flow rate reaches a value of 1 LPM (liter per minute); the unit will not allow the oxygen flow rate to go below this value. If the user attempts to lower the % OXYGEN while this message is displayed, the unit compensates by increasing the total flow rate.

FLUSH FLOW LOW: This message indicates that the oxygen flush flow rate is less than 10 LPM. Check the oxygen supply pressure.

CAUTION: Operate key pad with finger pressure only. Do not use hard or sharp objects. Failure to do so may result in DAMAGE to front panel.

Key Pad Controls

On/Off Key: The ON/OFF key controls the operation of the unit. Momentarily depressing the ON/OFF key changes power state from OFF to ON or ON to OFF.

Note: If the power to the unit is interrupted and then restored, either by disconnecting / reconnecting the power cord or by local power failure, the unit will display OFF. The operator must press the ON/OFF key to restart the unit. The unit will then display default values of 100% oxygen at 5 LPM.

CAUTION: After turning the device off, or when the unit is not in use, all oxygen and nitrous oxide supply cylinder valves must be closed.

Flow Control: The LPM FLOW key pad [▲ or ▼] controls the total flow rate delivered by the unit. Pressing the appropriate key momentarily increases or decreases the total flow rate by 0.1 LPM. By pressing and holding a key, the total flow rate indication changes slowly for the first two steps, then changes at a faster rate for the remainder of the time the key is held. An audible signal indicates that a limit has been reached.

%O₂ Control: The % OXYGEN key pad [▲ or ▼] controls the percentage of oxygen delivered by the unit. Press the appropriate key momentarily to increase or decrease the oxygen percentage one step (1% or 5%). Pressing and holding the key changes the oxygen percentage slowly for the first two steps, then faster for the remainder of the time the key is held. This varies the ratio of oxygen to nitrous oxide. An audible signal indicates that a limit has been reached.

Setting % OXYGEN Step Amount (1% or 5%): The DIGITAL MDM® mixer is shipped from the factory programmed to change 1% for each press of the % OXYGEN key pad [▲ or ▼]. The amount can be changed from 1% to 5% by using the DISPLAY N₂O and DISPLAY O₂ keys and the following procedure:

1. Press and hold the DISPLAY N₂O key.
2. While pressing the DISPLAY N₂O key, press the DISPLAY O₂ key until the audible alarm sounds.
3. Release both keys.

The audible signal indicates the change has occurred and is programmed in memory. The unit will remain in the new mode until this sequence is repeated. Unplugging or turning the unit off will not affect the programmed mode.

Flow Display Control: The key pad DISPLAY O₂ or DISPLAY N₂O select the gas flow rate displayed on the flow display. Press and hold the DISPLAY N₂O key to display the nitrous oxide component of the total flow. Press and hold the DISPLAY O₂ key to display the oxygen component of the total flow. If neither key is held, the LPM FLOW display indicates the total gas flow.

Oxygen Flush Key: Pushing the O₂ FLUSH key delivers 100% oxygen directly to the mixed gas outlet at the rear of the unit. This outlet is connected to the patient through the breathing tube connector (see Figure 2). While the key is pushed, 100% oxygen is delivered continuously at an approximate flow rate of 20 LPM. Releasing the key returns the unit to the flow rate and mixture ratio which were in effect prior to the flush.

Alarm Test/Silence Key: The alarm test / silence key serves two functions. When pressed, all the display, indicators and the audible alarm turns ON. This key also silences the audible alarm when a NITROUS FAILURE condition exists. The audible alarm will be silent for about five minutes and then resume, unless the failure condition has been corrected.

Machine Diagnostics

The DIGITAL MDM® mixer performs self checks at start up and during operation. If any errors are detected, the unit displays EE on the % OXYGEN display and an error code on the LPM FLOW display. If an error code appears, remove the unit from patient service and call the Matrx by Parker Technical Service Department at 1-888-723-4001.

To aid in the diagnostics of the unit, make note of the final error code displayed.

General Installation

Refer to FM-916 Mobile “E” Tank Stand Installation and Instructions for connecting gas supply to the flowmeter and tank installation to mobile stand.

If the optional Scavenger Control Valve was purchased separately, align it with the 2 holes on the base of the mixer. Secure with the (2) #10-32 screws. Following the instructions provided with the scavenging system, connect the Scavenger Control Valve to the vacuum system.

Installation of Rubber Goods

The assembly procedure for the DIGITAL MDM® mixer follows (see Figure 2):

1. Slide the breathing bag opening over the outside diameter of the bag mount.
2. Slide the 15mm fresh gas connector from the scavenger into the breathing tube connector.
3. If an accessory, such as the Scavenger Control Valve is used, connect it following the instructions supplied with it.

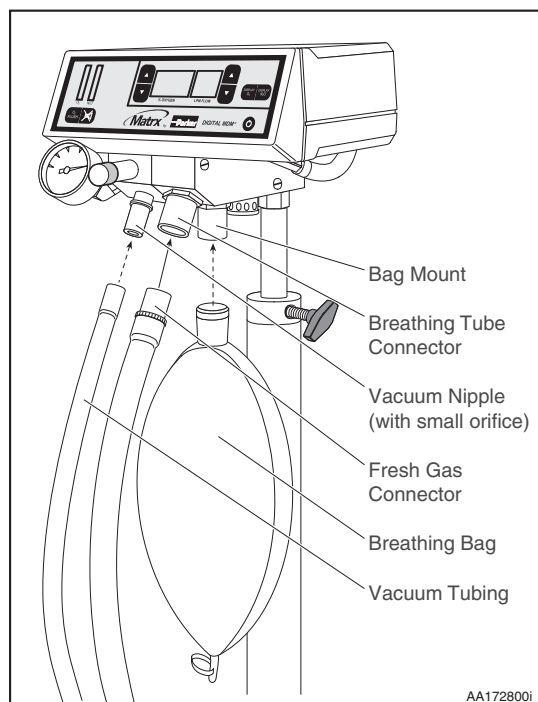

Figure 2 Installation of Rubber Goods.

Installation of Power Cord

Insert the power cord into the input connector on the rear of the unit (see Figure 3).

Connection of Oxygen – Nitrous Oxide

For safety reasons, gas connections are color-coded and mechanically indexed using the Diameter Indexed Safety System (DISS) to prevent accidental cross connection. DISS female hexagon fittings are standard for both hoses.

1. Connect the DISS female hexagon fitting of the nitrous oxide hose to the male DISS, N₂O INLET, fitting on the back of the mixer head (see Figure 3). Hand-tighten and then finish tightening with a 7/8” inch open end wrench (approximately 1/8 turn). *Do not over-tighten.*
2. Connect the DISS female hexagon fitting of the oxygen hose to the male DISS, O₂ INLET, fitting on the rear of the unit (see Figure 3). Hand-tighten and then finish tightening with a 11/16” inch open end wrench (approximately 1/8 turn). *Do not over-tighten.*

Hoses

Hoses are manufactured for connection to the gas source in various configurations:

- Quick Connect fittings are designed for rapid “no tool” connections with corresponding male / female fittings or outlet stations. Refer to the individual manufacturer’s instructions for specific connection procedure.
- DISS to DISS hoses are designed primarily for portable systems. The gas source (male) DISS fittings are located on the regulators on the cylinder mount block provided with the portable units. Connect the DIGITAL MDM® mixer to the cylinder mount block using the appropriate nitrous oxide hose and the oxygen hose.

Demand Valve Resuscitator

An optional Demand Valve Resuscitator for emergency oxygen resuscitation is available from Matrx (PN 91505085) and connects directly to the O₂ outlet (Figure 3) on the rear of the unit.

Figure 3. Connection to the back of unit

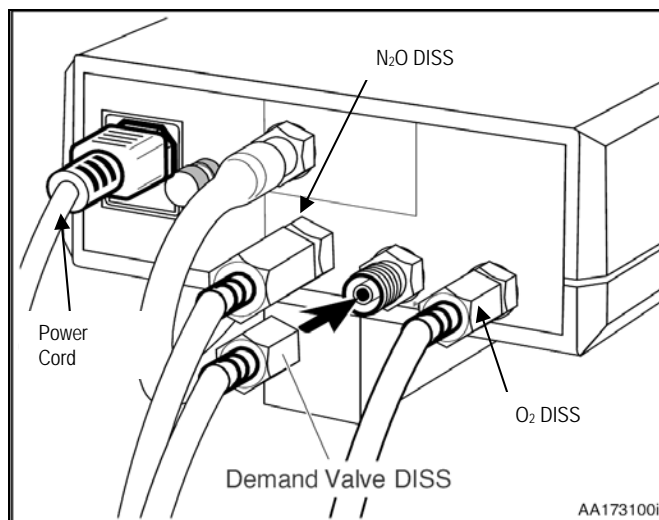

Preparation for Use

CAUTION: Before using the DIGITAL MDM® mixer, check the operation of the unit by performing the following tests.

Performance Checks: These preliminary tests must be conducted to ensure that your analgesia mixer is performing correctly. If the unit fails any one of the following performance checks, the unit must be returned for service.

Machine Turn-On Test:

Press the ON/OFF key, as shown in Figure 1. After the device goes through an initialization routine, the % OXYGEN and LPM FLOW displays should indicate 100% and 5 LPM.

Alarm Indicator / Lamp Test:

Press the alarm test / silence key, as shown in Figure 1, and observe that all the alarm readouts illuminate. The % OXYGEN and LPM FLOW displays should show 8.8.8. and 8.8 respectively. The alarm readouts should illuminate with the numerical displays. 10 bars on each gas should illuminate. The audible alarm should also sound.

Oxygen Failure Test:

Set the LPM FLOW display to 9.9 LPM. Set the % OXYGEN display to 50%. Turn off the oxygen gas supply to the unit. When the gas runs out, check for each of the following:

- the OXYGEN FAILURE alarm illuminates
- the audible alarm sounds
- the flow indicators are off
- the LPM FLOW and % OXYGEN displays are off

Turn on the oxygen gas supply, and the unit should return to normal operation. (The alarm may continue to chime for up to 20 seconds after restoration of gas pressure.)

Nitrous Failure Test:

Set the LPM FLOW display to 9.9 LPM. Set the % OXYGEN display to 30%. Turn off the nitrous oxide gas supply to the unit. When the gas runs out, make sure each of the following occurs:

- the NITROUS FAILURE alarm illuminates
- the audible alarm sounds
- the LPM FLOW display indicates the oxygen flow being delivered
- the % OXYGEN display is OFF
- the N₂O gas flow indicator is OFF
- the O₂ gas flow indicator shows at least 3 bars
-

Turn on the nitrous oxide gas supply. The unit should return to normal operation. (The alarm may continue to chime for up to 20 seconds after restoration of gas pressure.)

Indicated Flow Delivery Test:

Set the % OXYGEN display to 100%. Press the [▼] flow key and hold, as shown in Figure 1. The flow rate should decrease to 1.0 LPM. An audible alarm sounds at the lower limit while the key is held. Press the [▲] flow key and hold. The flow rate should increase to 9.9 LPM. An audible alarm will sound at the upper limit as long as the key is held.

Indicated Percentage (%) Delivery Test:

Set the LPM FLOW display to 9.9 LPM. Press and hold the [▼] % OXYGEN key. The % OXYGEN display should decrease to 30%. The audible alarm sounds at the lower limit while the key is held. Press and hold the [▲] % OXYGEN key, as shown in Figure 1. The % OXYGEN display should increase to 100%. An audible alarm sounds at the upper limit while the key is held.

Basic Delivery Technique:

Practice titration. Titration is a method of administering a substance by adding definitive amounts of a drug until an endpoint is reached. For nitrous oxide / oxygen (N₂O) / O₂) sedation, N₂O is given in incremental doses until a patient has reached a comfortable relaxed state of sedation. The ability to titrate N₂O is a significant advantage because it limits the amount of drug to that which is required by the patient. If titration is done properly, the patient does not receive any more of the drug than is necessary. The amount of N₂O required by a patient on any given day or time varies.

For information on titration, a most valuable resource for the practitioner is the Handbook of Nitrous Oxide and Oxygen Sedation, written by Clark and Brunswick and published by Mosby (www.mosby.com). This text is a concise and contemporary guide for nitrous oxide / oxygen administration.

Maintenance

The DIGITAL MDM® mixer is a precision analgesia mixing unit. As with any medical instrument, it requires periodic inspection and maintenance. The following routine maintenance procedures should be performed to ensure system integrity and trouble-free service.

-Inspect mixer, hoses, and connections daily for damage, wear, and leaks.

-Perform functional tests prior to each use. These tests are described in Performance Checks,

-While cleaning the outside of the unit, observe caution so that liquid does not get inside. Matrix by Parker recommends using a damp (wrung toward dry) cloth moistened with a mild soap or a plastic-safe cleaner. Do not spray directly on the case. A hard surface disinfectant may be applied in the same manner. **CAUTION: DO NOT submerge the unit—use a damp cloth.**



WARNING: Before cleaning the unit, disconnect the DIGITAL MDM mixer's power cord from the electrical power supply.

Fuse Replacement-International, 220-240V

1. To replace a blown fuse, turn the unit OFF, disconnect power to the unit by unplugging the power cord from the wall, and then remove the power cord from the input connector on the rear of the unit.
2. Open the fuse compartment, as shown in Figure 4.
3. Remove each blown fuse from its clip and replace it with a 5mm x 20mm cartridge fuse, rated 2.5 amp, 250 volt, slo-blo (time delay), part number 63882537. Two fuses are required for the unit to operate.

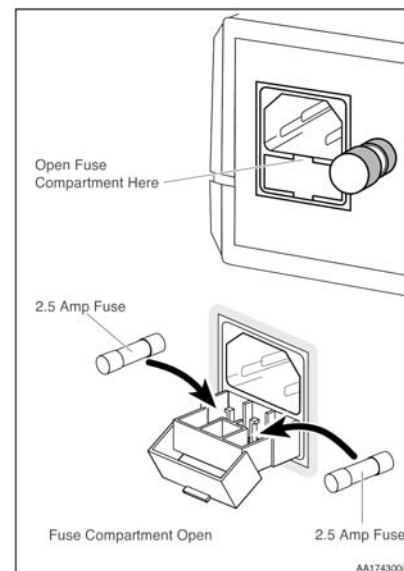

Figure 4 International Fuse Replacement

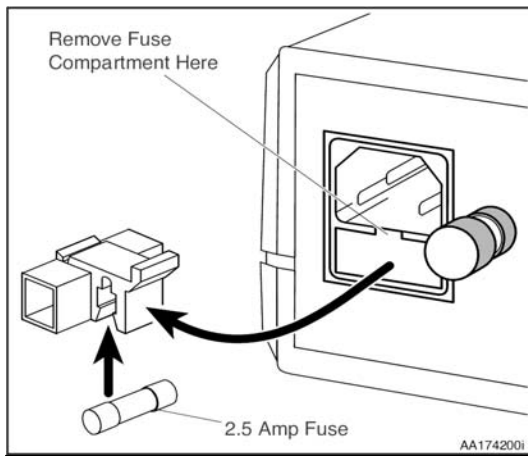

Figure 5 Domestic Fuse Replacement

Fuse Replacement- Domestic 115–120 V

1. To replace a blown fuse, turn the unit off, disconnect power to the unit by unplugging the power cord from the wall, and then remove the power cord from the input connector on the rear of the unit.
2. Remove the fuse compartment, as shown in Figure 5.
3. Remove the blown fuse from its clip and replace with a 5mm x 20mm cartridge fuse, rated 2.5 amp, 250 volt, slo-blo (time delay), part number 63882537.

Specifications

Physical

Dimensions: 8" W x 5.5" H x 10" D
Weight: 6 lbs.

Fittings

Fresh Gas Outlet: 15mm ID x 22mm OD
Nitrous Oxide Inlet: Male DISS CGA 1040
Oxygen Inlet: Male DISS CGA 1240

Environmental

Storage Temperature: -10°F to 120°F
(-17°C to 48°C) (Allow to stabilize to room temperature before operating.)
Operating Temperature: 72°F nominal (22°C)
Humidity: Ambient, non-condensing

Gas Supply

Oxygen Inlet

Pressure Requirements: 50 to 55 psi
Flow Requirements: 30 LPM minimum flow

Note: A minimum oxygen flow of 120 LPM is required when using the optional Demand Valve Resuscitator.

Performance and Accuracy (Controlled Variable 50 – 55 PSIG Sources)

Oxygen Flowrate from 1.0 to 9.9 ±0.5 LPM
Nitrous Oxide Flowrate from 1.0 to 7.0 LPM ±0.5 LPM
Nitrous Oxide Flowrate from 0.1 to 1.0 LPM +0.5 / -0.9 LPM
Percent O₂: ±5 % points @ N₂O > 1.0 LPM
Percent O₂: +20 / -10 % points @ N₂O < 1.0 LPM
Pure Oxygen Flush: 20 LPM Nominal at 50 PSIG Input

Nitrous Oxide Inlet

Pressure Requirements: 50 to 55 psi
Flow Requirements: 10 LPM minimum flow

Gas Delivery

Oxygen Flush: 10 to 30 LPM (20 LPM nominal @ 50 psi input)
Minimum Nitrous Oxide Concentration: 00%
Maximum Nitrous Oxide Concentration: 70%
Minimum Oxygen Concentration: 30%
Maximum Oxygen Concentration: 100%
Flow Range @ 100% Oxygen: 1.0 to 9.9 LPM
Flow Range @ Any % Mixture: up to 9.9 LPM†
(†Low end flow limited by 1.0 LPM oxygen limit)

Electrical (Domestic 115–120 V)

Input Voltage Supply: 115 VAC nominal
Input Line Frequency: 60Hz
Circuit Protection: 2.5 amp time delay fuse (Matrix PN 63882537)

Electrical (International 220–240 V)

Input Line Frequency: 50–60Hz
Circuit Protection: two, 2.5 amp time delay fuses (Matrix PN 63882537)

Check out our website www.porterinstrument.com for the following topics.

Flowmeter Mounting Options, Flowmeter Accessories, Product Warranty and Registration And Downloading User Manuals