

# Thou Shalt Communicate!

## Wi-Fi/Bluetooth/USB shield for Platino and Arduino

By Clemens Valens  
(Elektor UK/INT Editorial)

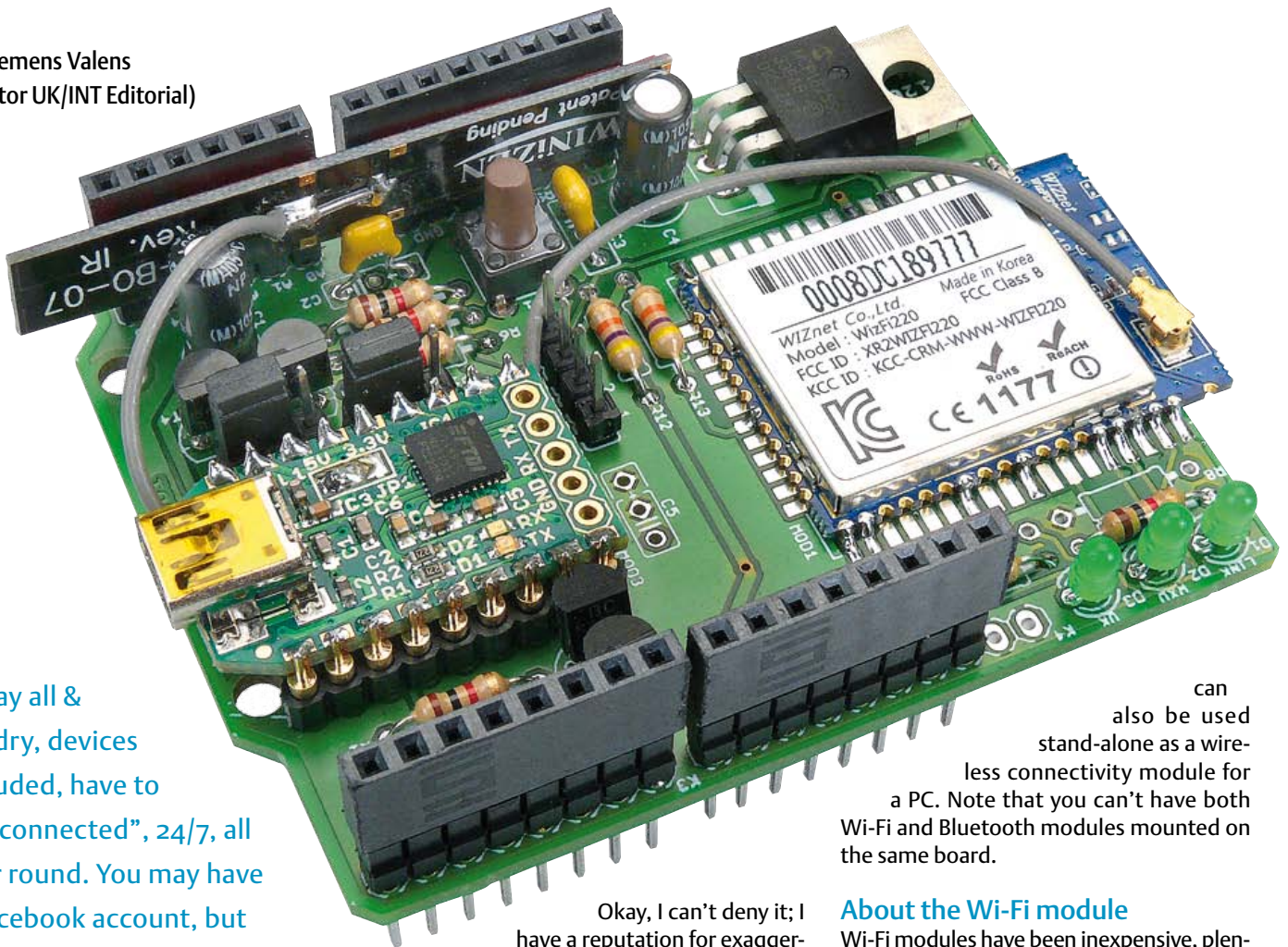

Today all & sundry, devices included, have to be “connected”, 24/7, all year round. You may have a Facebook account, but what about your oscilloscope? Does your multimeter tweet enough? Is your soldering iron linked in? You may be a non-communicative nerd but your bench power supply may be craving for social interaction. With the add-on board described in this article you can hook up anything to everything, with or without wires.

Okay, I can’t deny it; I have a reputation for exaggerating. Connecting anything to, errm, everything is probably a bit over the top. On the other hand, the board I’m about to present in this article is quite versatile. It can be equipped with a Wi-Fi module allowing you to connect an electronic device to the Internet; or with a serial Bluetooth module it offers wireless connectivity to other serial Bluetooth capable devices, and a serial-to-USB bridge enables old-skool wired serial connectivity.

The board can be used as an add-on board for microcontroller systems with Arduino-style extension connectors (Figure 1), like Elektor’s own Platino [1] (Figure 2), but it

can also be used stand-alone as a wireless connectivity module for a PC. Note that you can’t have both Wi-Fi and Bluetooth modules mounted on the same board.

### About the Wi-Fi module

Wi-Fi modules have been inexpensive, plentiful and easy to find these past few years. The problem with many of them however is their manufacturer who refuses to tell you how to use the module unless you agree to transfer a substantial amount of money to the manufacturer’s bank account in exchange for a few thousand modules or a customised software library for your host hardware. Luckily the Korean embedded Internet liberators from WIZnet have decided to be less secretive about their products, and sell Wi-Fi modules you can actually use. I managed to get my hands on two of their WizFi220 modules, and this article is the result.

The WizFi2x0 modules (there is also a WizFi210 module) operates with standard 802.11 b/g/n access points at speeds up to 11 Mbit/s (802.11b), and they support WEP, WPA, WPA2-PSK and Enterprise security standards (802.11i). The modules have some really cool possibilities. One of them is the Wi-Fi serial port that's remarkably easy to use. Another nice feature is its limited access point (AP) capability that allows direct connection to smartphones and tablets like Android-based devices and Apple gadgets.

The WizFi220 module measures 32 x 23.5 x 3 mm, has an on-board chip antenna and a Hirose U.FL connector for an external antenna. The module's compatible little brother, the WizFi210, consumes less power, but cannot provide as much output power and hence has "less range". 49 connection pads provide enough soldering points to fix the module on a PCB in such a way that it will not easily come off. Most of these pads are probably not useful for unassuming users like us, being pitched at high-volume customers. For the others a simple two-wire serial connection is available to transmit and receive data and to configure the module.

As is often the case with such wireless modules, the WizFi2x0 can be controlled over a serial link using AT modem commands (or Hayes commands). Such commands consist of human-readable strings a few characters long and starting with 'AT'. The module powers on in Command mode so you can configure it. Once the setup is complete the module can be switched into Data mode with the O(nline) command ("ATO"). To get it out of Data mode back to Command mode three consecutive '+' characters have to be send ("+++").

## Design considerations

Some of the configuration commands, like setting the baud rate of its serial port, are more or less one-time only, and the module remembers these settings. Since the AT commands are human-readable it may therefore be practical for the initial setup, but also for experimenting, to be able to communicate with the module using a PC

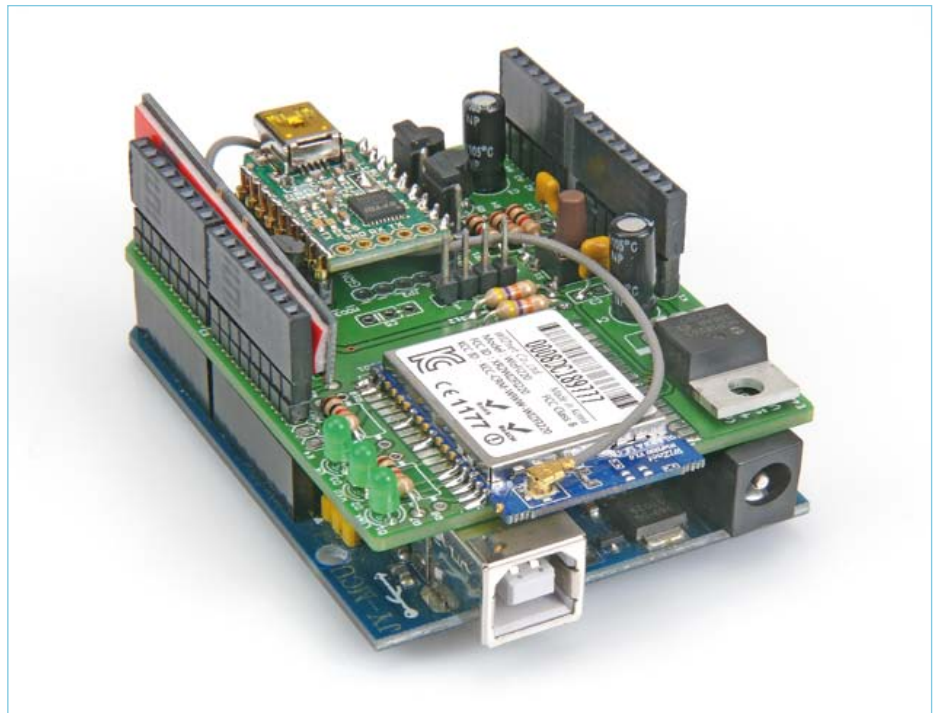

Figure 1. Fully built up Wi-Fi shield on top of an Arduino Uno. Note the absence of R8 and R10.

and a serial terminal program. That's why I decided to throw in a serial-to-USB converter. Since many Elektor readers may already have a so-called FTDI serial USB cable [2], I wanted to be able to use it with this module. On the other hand, having such a converter directly on the board would also be useful, especially if the host

system does not have a USB serial port, like Platino. In the September 2011 edition we presented BOB [3], a very convenient USB/serial bridge module, and I thought it was a good idea to add it to my design too. Now if I could add some clever wiring it should be possible to connect the USB converter to either the Wi-Fi module, the



Figure 2. Fully built-up Wi-Fi shield on top of Platino, also equipped with a 20x4 alphanumeric LCD.

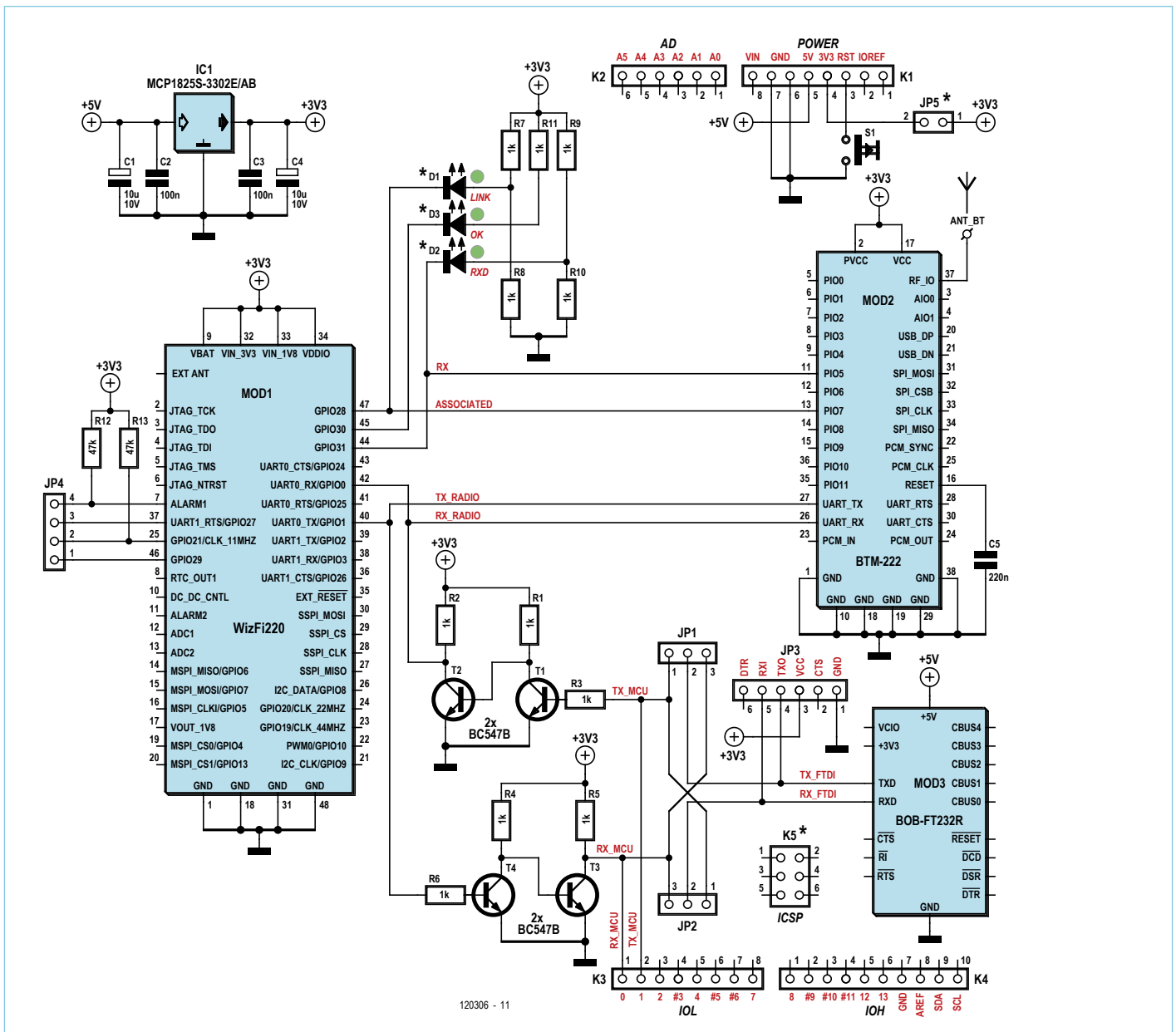

Figure 3. Complete circuit diagram of the Wi-Fi/Bluetooth/USB shield. Refer to the text to find out which parts you need for each configuration.

host system or even disconnect it. Flexibility started creeping into the design. The Wi-Fi module has to be powered from a 3.3 V rail and it is not 5 V tolerant. The main objective is to connect the Wi-Fi module's serial port to a microcontroller. Such a system may run from 3.3 V, but if it is Arduino or Platino, then the microcontroller runs from 5 V. Level converters on the serial port would therefore be necessary. The FTDI serial USB cable comes in two flavours, 5 V and 3.3 V, and with level converters both types would be usable. The BOB was not an issue because it can handle both levels. Although the host system may have a 3.3 V

rail, like Arduino, I thought it wise to add a voltage regulator to the system because the WizFi220 can consume up to 250 mA in active mode. As an example, the LP2985-33 voltage regulator on an Arduino Uno board is specified for 150 mA, which is clearly not enough. Platino does not have a 3.3 V rail so this shield could provide it too. A jumper should allow connection of the 3.3 V as produced by the shield to the host system. In this section you can replace all instances of "Wi-Fi" by "Bluetooth" without having to change anything else and still have a coherent text. Indeed, many Bluetooth modules are very similar to the WizFi module: they

can be controlled with AT commands over a serial link; they run from 3.3 V; they have similar dimensions and similar requirements. It is therefore not very difficult to add Bluetooth capabilities to the system, all you have to do is wire a usable Bluetooth module in parallel with the Wi-Fi module and that is what I did. I chose the Rayson BTM220 module because I am at ease with it [4] and it is very cheap. We have used it several times in Elektor too. [5][6]

This completes the reasoning that determined my design. Let's now have a closer look at the circuit diagram (Figure 3). If you

## COMPONENT LIST

### Resistors

R1–R11 = 1kΩ 5% 0.25W  
 R12, R13 = 47kΩ 5% 0.25W

### Capacitors

C2, C3 = 100nF 50V, 5mm pitch  
 C5 = 220nF 50V, 5mm pitch  
 C1, C4 = 10μF 35V, 2.5mm pitch

### Semiconductors

D1, D2, D3 = LED, green, 3mm diam.  
 T1–T4 = BC547C, TO-92 case  
 IC1 = MCP1825S-3302E/AB, 3.3 V voltage regulator, TO-220 case

### Miscellaneous

JP1 = 6-pin pinheader, 0.1" pitch, straight  
 JP2 = 4-pin pinheader, 0.1" pitch, straight  
 JP3, JP4 = 3-pin pinheader, 0.1" pitch, straight, w. 2 jumpers

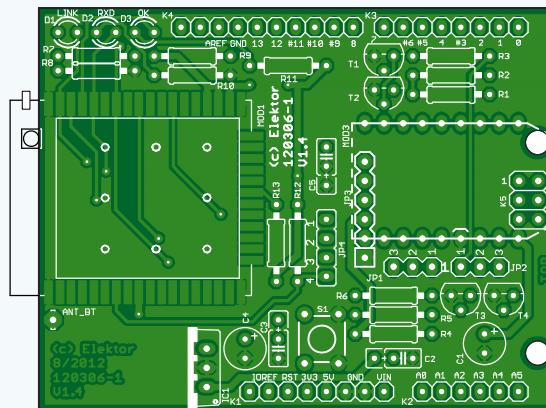

K2 = 6-pin stackable header, 0.1" pitch, vertical  
 K5 = 6-pin (2x3) stackable header, 0.1" pitch, vertical  
 S1 = pushbutton, SPNO, through-hole, 6x6mm  
 Mod3 = BOB-FT232R USB-to-Serial Bridge, Elektor Shop # 110553-91, or USB-to-Serial cable, Elektor Shop # 080213-71 (5 V) or # 080213-71 (3.3 V)  
 Mod2 = Rayson BTM22x Bluetooth module  
 Mod1 = WIZnet WizFi2x0 Wi-Fi module  
 PCB # 120306-1 [1]

have grasped my prose up to here, then the schematic will have only a few surprises.

### Putting it all together

On the left side of figure 3 we have the Wi-Fi module; on the right side we see the Bluetooth module. As you can see they share the serial RX and TX lines, meaning that you should not mount both. It is either Wi-Fi or Bluetooth, never both. The modules also share two LEDs (D1 and D2); D3 is only used by the Wi-Fi module. A surprise here may be R8 and R10. Maybe I could have drawn a better schematic, but I didn't, so I have to explain this in writing. It is actually very simple. The Wi-Fi module sinks the current for the LEDs whereas the Bluetooth sources the current. As a result the LEDs have to be mounted the other way around as drawn if you use the Bluetooth module. In that case you should mount R8 and R10 and **not mount** R7 and R9 (mounting R11 and D3 is useless unless you connect the LED to a free I/O pin on one of the connec-

tors). For the Wi-Fi module the position of the LEDs is drawn correctly and you should **not mount** R8 and R10 (although nothing breaks or blows if you do), only R7 and R9 are needed now.

The WizFi module has some pins with special functions that you may want to use. Since I didn't use them I wired them to a separate connector JP4. To enable you all to stack many shields on top of each other I decided not to wire these signals to the Arduino extension connectors K1 to K4. If you need them you can wire them yourself. Pin 25 (GPIO 21) allows you to restore the module's factory defaults. Pulsing it Low twice will restore the module to Limited Access Point mode, three pulses will restore it to Ad-hoc mode. Pin 46 (GPIO 29) provides a hardware way of switching between Command (High) and Data mode (Low). Pin 37 (GPIO 27) is needed when you want to upgrade the firmware of the module (probably never). To do so

you have to pull it High. Finally, a low level on pin 7 (Alarm1) will wake up the module from deep sleep mode.

The level converters (R1-3, T1-2 and R4-6, T3-4) are straightforward and have been used before in Elektor. Transistors T1 and T4 do the level conversion, but invert the signal at the same time. T2 and T3 correct this. The resistor values are not critical. I chose to use as many 1 kΩ resistors as possible. The RX and TX lines connect to JP1 and JP2. These 3-pin jumpers may be a bit difficult to understand at first sight, but when you follow the lines you should be able to figure them out. With a jumper on JP1's pins 1 and 2 the USB serial converter TX pin is connected to the Wi-Fi (or Bluetooth) module's RX input. A jumper on JP2's pins 2 and 3 connects the USB serial converter RX pin to the Wi-Fi (or Bluetooth) module's TX output. This is the Configure-Module-With-PC mode. In these positions the USB serial converter cannot talk to the host MCU system and it may be better to disconnect

## Elektor Projects & Products

- Platino, a versatile board for AVR microcontroller circuits (October 2011); PCB # 100892-1 from Elektor Shop
- BOB-FT232R USB-to-Serial Bridge (September 2011); module, Elektor Shop # 110553-91
- USB-to-TTL Serial Cable (June 2008); cable, Elektor Shop # 080213-71 (5 V) or # 080213-71 (3.3 V)

## Listing 1.

Example of setting up the WizFi2x0 module as a serial server using AT commands. The commands are in **boldface**, the module's responses are in *italic*. Comments appear in brackets (). See the WizFi2x0 user manual for more commands.

```

AT (wake up)
[OK]
AT+NSTAT=? (what is your status?)
MAC=00:08:dc:18:97:76
WSTATE=NOT CONNECTED MODE=NONE
BSSID=00:00:00:00:00:00 SSID="" CHANNEL=NONE SECURITY=NONE RSSI=0
IP addr=0.0.0.0 SubNet=0.0.0.0 Gateway=0.0.0.0 DNS1=0.0.0.0 DNS2=0.0.0.0
RxCount=0 TxCount=0
[OK]
AT+WPAPSK=germaine,"Philippe Noirette" (set SSID & pass phrase)
Computing PSK from SSID and PassPhrase...

[OK]
AT+NDHCP=1 (request IP number from DHCP server)
[OK]
AT+WAUTO=0,germaine (automatically connect to germaine)
[OK]
AT+NAUTO=1,1,,8011 (setup for auto connect: server, TCP, port 8011)
[OK]
ATA (start auto connect)
   IP SubNet Gateway
   192.168.2.7: 255.255.255.0: 192.168.2.1
[OK]

```

(now you can connect (telnet) to the module over Wi-Fi)

the board from the host system. The board will be powered from the USB port.

If you put a jumper on JP1's pins 2 and 3 and on JP2's pins 1 and 2 the USB serial converter can be used to talk to the host system. In this case you should not mount the wireless module (or the level converters) as this kind of communication may disturb it. This is the USB-Shield mode.

Not installing any jumpers will put the board in Wireless mode and the USB serial converter has no use. However, you could leave it on and wire it to other pins on the extension connectors. This is for instance useful in an Arduino-with-software-UART configuration or in a host system with more than one UART.

Finally some remarks on details. The Reset button is mainly intended for Platino which doesn't have one. It is also useful when the Arduino reset button becomes inaccessible

because of the shield mounted on top of it. This depends on the Arduino board and its revision.

K5 is not connected. I only put it on the board to provide access to its signals if the host is Arduino.

### Turning practical

To turn a circuit diagram into a real shield or extension board a printed circuit board (PCB) is needed. I designed one and you can download the Eagle CAD files from the web page that accompanies this article [7]. The PCB is the size of an Arduino Uno except that it is a rectangle without the funny-shaped short side of an Arduino Uno. All the components are through-hole types; only the Wi-Fi and Bluetooth modules have surface mount footprints. JP5 and the Bluetooth module are located on the solder side of the board; the other components should go on the component side. Note that if you use non-stackable

connectors for K1 to K4 you should mount them on the solder side if you want to stick the board on an Arduino or Platino.

JP1 and JP2 are positioned in such a way that the jumpers should always be in the same position, i.e. both to the left, both to the right or both absent. Actually, you could leave a jumper on JP2 in case you wanted to listen in on the MCU wireless module communications. This can be useful for debugging purposes.

JP3 has a few contacts in common with the BOB serial-to-USB bridge, the idea being that you use either a BOB or an FTDI cable, not both.

For full 3.3 V systems the level converters and voltage regulator can be left off. In this case you have to place two bypasses (wire bridges) from R3-JP1 to R2-T2 and from R6-MOD1 to R5-T3. Resistors R3 & R2 and R5 & R6 are positioned in such a way that the wire bridges are very easy to install and



Figure 4. The three main configurations next to each other. The Bluetooth module is not visible (middle board) because it is mounted on the other side of the PCB. Note that this is an early revision of the PCB that has the same shape as an Arduino Uno board. The final PCB is rectangular.

span only minimum distance. You will also have to short JP5 on the solder side of the board.

As mentioned before, the orientation of the LEDs depends on the wireless module. The component print on the PCB corresponds to the Wi-Fi module. If you mount a Bluetooth module you should mount the LEDs D1 and D2 ‘the wrong way around’. Also, only mount R7 or R8 and R9 or R10.

The 3.3 V voltage regulator can be installed lying on his back or standing up.

Three main configurations are possible (Figure 4), but you may have a need for other variants:

- **Wi-Fi shield** — no need for the BOB if you own an FTDI cable, although you can always install one. JP3 is available for connecting the FTDI cable. Mount all LEDs as indicated on the PCB and do not mount R8 nor R10. Level converters will be needed and the 3.3 V voltage regulator probably too, depending on your host system.
- **Bluetooth shield** — similar as the Wi-Fi shield except for the LEDs. D3 has no function and you should not mount R7 and R9 but mount R8 and R10 instead. As an antenna you can use a piece of (insulated) wire of 31 mm long.
- **Serial-to-USB bridge shield** — just the BOB without level converters. Do not

forget to put a drop of solder on JP1 of the BOB to configure it for 5 V or 3.3 V operation. Add 3.3 V voltage regulator and reset push button to taste. The LEDs can be useful too, but you will have to wire them to a connector pin. You should short pins 2 and 3 of JP1 and pins 1 and 2 of JP2 with a jumper or a wire bridge.

## Testing

In case of the Wi-Fi or Bluetooth configurations connect the board to a USB port on the PC using an FTDI serial converter cable or the BOB serial-to-USB bridge. Figure out which COM port was created by the operating system (OS) of your PC (make sure you have the appropriate drivers for your OS installed. If you haven’t you can get them, including the necessary documentation, at [www.ftdichip.com](http://www.ftdichip.com)) and start a serial terminal program. The WizFi220 module has a default baud rate of 115 200 bits/s, for the BTM220 module this value is 19 200. Both modules use 8 bits, no parity and no hardware flow control. In the terminal type ‘AT’ followed by the Enter key. If you set up everything the right way the module should respond with ‘[OK]’ or ‘OK’. If this test succeeds you’re in business. Refer to Listing 1 for a working Wi-Fi example (don’t forget to adapt the SSID and pass phrase to your network). For a BOB serial-to-USB bridge configuration the steps are more or less the same except that there is no point in punching in AT commands in the terminal unless your

host system responds to these. It is up to you to provide a host that can communicate over a serial link.

*Thanks go out to Joachim Wulbeck of WIZnet Europe GmbH ([www.wiznet.eu](http://www.wiznet.eu)) for providing the WizFi220 modules and the Wi-Fi antennas.*  
(120306-1)

## Internet Links and References

- [1] **Platino:** [www.elektor.com/100892](http://www.elektor.com/100892)
- [2] **USB-to-TTL serial cable:** [www.elektor.com/080213](http://www.elektor.com/080213)
- [3] **BOB serial-to-USB bridge:** [www.elektor.com/110553](http://www.elektor.com/110553)
- [4] **Experiments with Rayson Bluetooth modules:** <http://elektorembded.blogspot.com/2010/08/rayson-btm222-btm112-bluetooth-modules.html>
- [5] **Bluetooth with the ATM18:** [www.elektor.com/080948](http://www.elektor.com/080948)
- [6] **Bluetooth for OBD-2:** [www.elektor.com/090918](http://www.elektor.com/090918)
- [7] **Wi-Fi shield:** [www.elektor.com/120306](http://www.elektor.com/120306)
- [8] **Wi-Fi shield on Elektor Projects:** <http://www.elektor-projects.com/project/wi-fi-bluetooth-usb-shield-for-arduino-platino.12252.html>