

# USER MANUAL

IMPORTANT: Keep all packaging for future reference



## RAIDER MOTORIZED BOAT

Model No. FL95002

### WARNING

THIS IS NOT A LIFESAVING DEVICE

#### CAUTION

##### ELECTRICALLY OPERATED PRODUCT

Not recommended for children under 8 years of age. As with all electrical products, precautions should be observed during handling and used to reduce the risk of electric shock.

#### WARNING

Read the User Manual carefully before using this product. • This is not a lifesaving device. • DO NOT leave children unattended while in use. • Always wear a coast guard approved personal floatation device. • Use in a pool or in calm water and close to shore. • DO NOT use in open waters, high winds, rapid current, dangerous tides, in waves, wakes or in bad weather conditions as it may not allow you to come back to shore. • NEVER stick body parts, clothing or other objects in the vicinity of the propeller. • DO NOT wear loose or flowing clothing or equipment that could be drawn into the Propeller. • Particular care should be exercised when using this product near any body with long hair. Users with long hair should tie it up or wear a swimming cap when using this product. • Always charge battery to its fullest before using this product. Ensure sufficient battery charge remains for return to shore. • ALWAYS inspect the swimming area to ensure it is free of hazards or obstacles such as boats and swimmers before using this product. • Be aware of appropriate water levels, tidal changes, dangerous currents, weather changes and strong offshore winds. Always scout unfamiliar water. • DO NOT use alcohol or mind-altering drugs prior to using this product. • DO NOT operate this product out of the water to avoid damage. • ALWAYS keep this product out of direct sunlight when not in use. HEAT KILLS BATTERIES. • Children under 8 years old should NEVER operate this product. • DO NOT ride over swimmers or other objects. • DO NOT use at night or in low light situations. • This product is to be operated only when fully assembled in accordance with the instructions. • NEVER leave in or near water when not in use. • NEVER tow from any vehicle • Adults should inflate the chambers in numbered sequence. • NEVER allow diving into this product • Not for use of more than 2 people, not exceeding 200lbs/90kgs. • DO NOT turn up side down of this product while in use. • Please disassemble, properly pack into the box/carrybag and store in in-house area while not in use. • DO NOT store in garage, outside open area or outdoor during the Fall/Winter season. • Filled with cold air only. • DO NOT over inflate or use high pressure pump to inflate. • Inflate the small chambers slowly.

Distributed by **Stallion sport LTD.**  
Block F, 6/F, Wah Hing Industrial Mansions  
36 Tai Yau Street, San Po Kong, Kowloon, Hong Kong

Toll Free: 1-877-2650996  
service@stallionsport.com  
www.stallionsport.com

**Stallion**  
Product

FLUID® and the LIQUID DRIP logo are trademarks of Stallion Sport or its affiliates, used under licence to Stallion (asia) Ltd.

FLP95002

### Parts Diagram

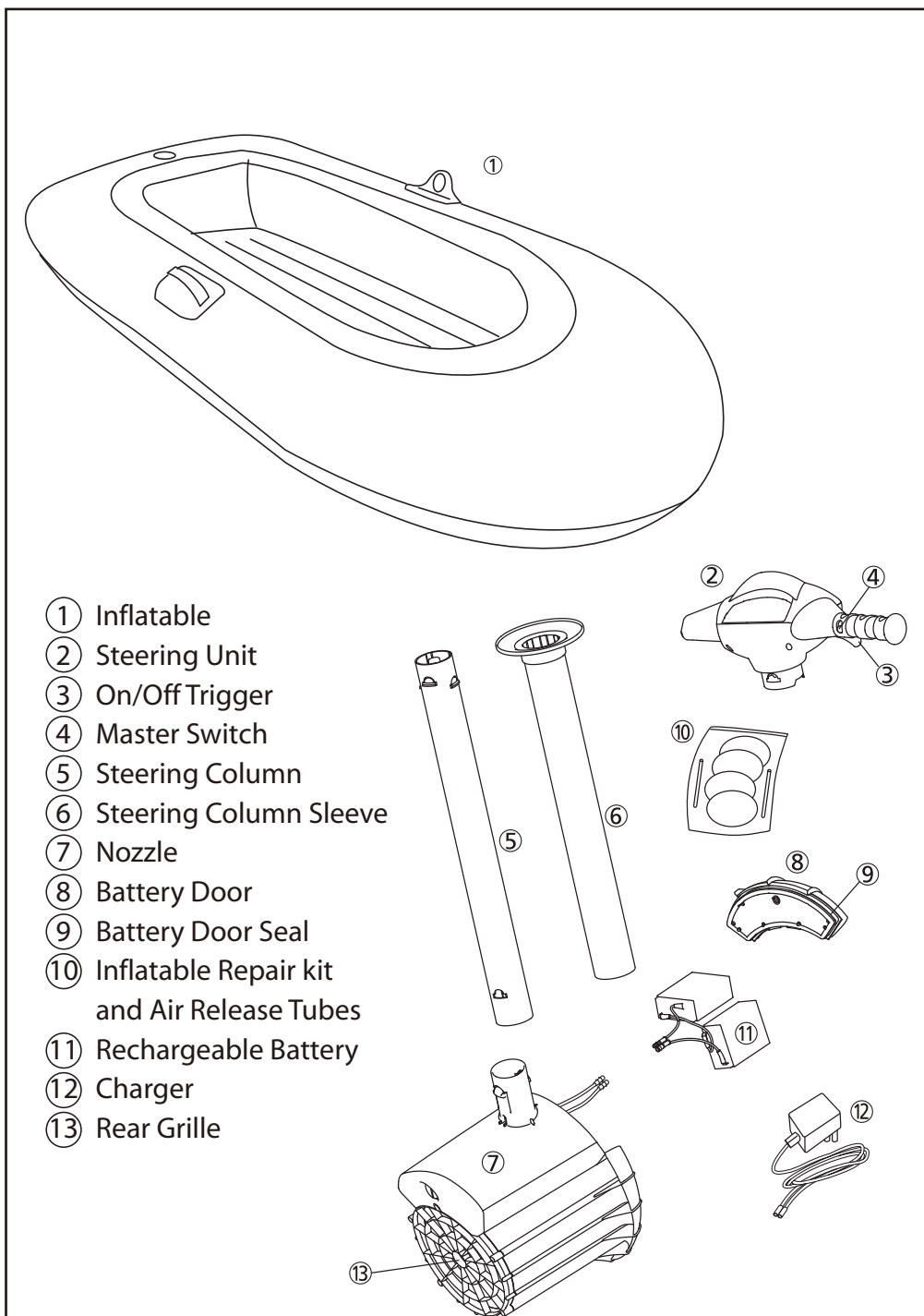

### Getting Started

When you use the MOTORIZED BOAT for the first time, the Inflatable needs to be assembled and the battery needs to be charged. Follow the instructions in "Battery Use", for charging and connection.

To assemble the MOTORIZED BOAT follow these instructions.

- Slide the Steering Sleeve into the hole in the Inflatable from the top. (See Fig. 1)
- Use a pump (not included) to blow up the inflatable in the sequence shown (See Fig. 2). ① inside floor channel A, ② inside floor channel B, ③ inside front wall ④ outside top at the back of the boat. Close the valve for each chamber once inflated.

NOTE: Recommended inflated pressure is 0.2 psi.

- 3A. Connect the Steering Column to the Nozzle (See Fig. 3). You will hear a "Click" sound once it has been correctly connected.
- 3B. Slide the Steering Column / Nozzle from the bottom of the inflatable through the Steering Sleeve. You will hear a "Click" sound once it has completely passed through the Steering Sleeve (See Fig. 4).

TIP: If the Steering Column Sleeve is stuck, pour some water to lubricate and then push it down.

- Attached the Steering Unit to the Steering Column. You will hear a 'Click' sound once it has been correctly connected (See Fig. 5).
- Make sure the Nozzle and the Steering unit are correctly aligned. (See Fig. 5)

### TO USE THE MOTORIZED BOAT FOLLOW THESE INSTRUCTIONS

- Charge the battery before use - refer to "Battery Use" for instructions.
- Place the MOTORIZED BOAT in the water.
- When ready to set off, turn the Master Switch to the ON position (See Fig. 6).
- Pull the trigger to start, turn the steering unit to maneuver and release the trigger to stop. (See Fig. 6)

**WARNING: Please disassemble, properly pack into the box / carrybag and store in in-house area while not in use. DO NOT storage in garage, outside open area or outdoor during the Fall/winter season.**

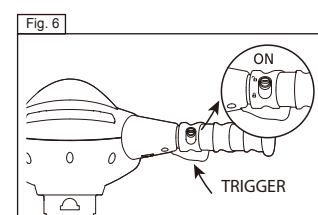
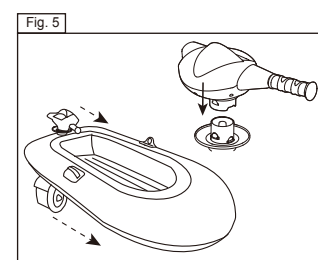
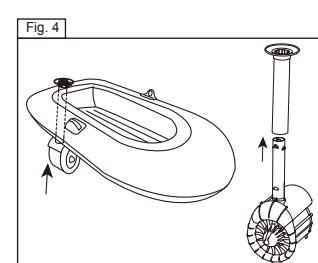
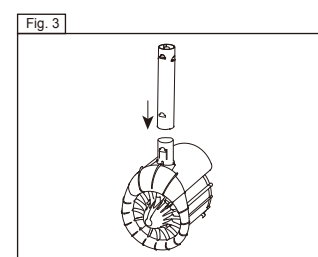
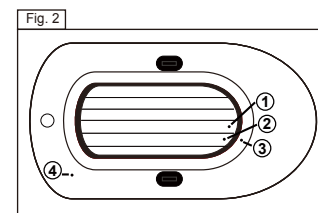
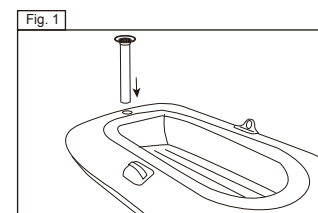

### CARE INSTRUCTIONS

**ALWAYS WASH ALL COMPONENTS IN CLEAN FRESH WATER AFTER USE**

Disassemble and wash all of the components in fresh water after use to avoid corrosion and unnecessary wear and tear.

**ALWAYS DRY ALL COMPONENTS BEFORE STORING**  
**ALWAYS RECHARGE THE BATTERY WITHIN 24 HOURS OF USE**

**ALWAYS RECHARGE THE BATTERY EVERY 3 MONTHS AND AFTER USE**

### ATTENTION

**Ensure every valve on the inflatable is completely sealed after inflation.**

**Inspect all valves every 2 hours after inflation**  
**Always inspect the pressure of the inflatable when in use.**

#### Battery Use

### CHARGING THE PROPELLER BATTERY

For battery charging follow these instructions.

- Always ensure that the Master Switch is OFF (See Fig. 7).
- Always ensure that the unit is out of the water and placed in a dry area.
- Unscrew the Battery Door using a coin or similar to remove. (See Fig. 8).
- Allow two minutes for any gasses to dissipate.
- Take out the battery from the Battery Compartment.
- Connect the Battery to the Charger. (See Fig. 9)
- Plug the Charger into mains, and turns on the supply.
- Charging will take 6-10 hours for a fully discharged battery. when the battery is charging the LED on the charger turns RED. When the battery is charged the LED turns GREEN.
- Unplug the Charger from the mains.
- Unplug the battery from the charger.
- Connect the battery and install it, making sure to insert it the right way around (See Fig. 10, A), and all wires are moved clear of the screw area (See Fig. 10, B).
- Make sure the seal and sealing surfaces are clean and lubricated before replacing the Battery Door (See Fig. 11). Use silicon grease to lubricate the seal - this can be purchased from your local hardware store.
- Replace the Battery Door and turn the Battery Door Screw making sure it is tightened completely. (See Fig. 12).

### REPLACING A FLAT BATTERY

To replace a flat battery with a fully charged battery, follow these instructions.

- Follow the steps 1 to 5 above.

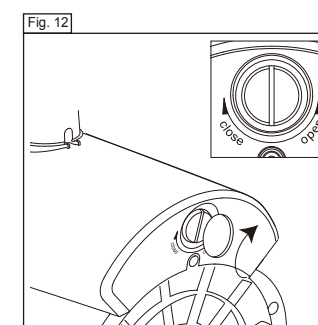
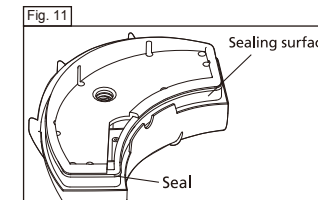
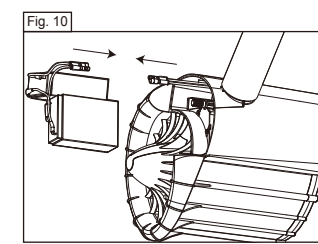
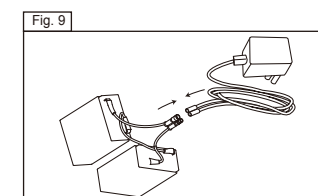
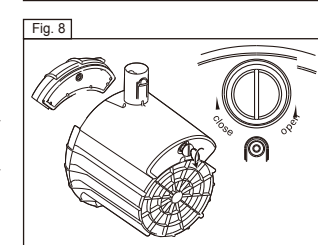
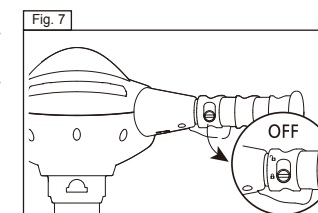

- Remove the flat battery.
- Install and connect the charged battery.
- Follow steps 12 to 13 above.

#### Battery and Charger Care

- The battery should be recharged as soon as possible after use.
- If this product is not used for extended periods, the battery should be removed from the unit and charged overnight, every three months.
- Only use the charger supplied with this product.
- Never place the battery in a sealed container when charging.
- Never short-circuit the battery or battery cable.
- Never place/store the battery near a radiator/fire, etc.
- To store the battery, remove it from the Battery Compartment and keep in a place that is dry and cool with the rest of the unit in the original box.
- Rechargeable batteries are to be removed from the Battery Compartment before being charged.
- Rechargeable batteries are only be charged under adult supervision.
- The battery charger should be required examined by an adult for potential hazard, such as damage to the cable or cord, plug, enclosure or other parts, and that, in the event of damage, the charger must not be used until that damage has been properly removed.
- Remove the battery from the battery compartment immediately after use.
- Dirt and sand can damage the seals in the battery compartment. Always ensure that the seals are cleaned and lubricated before closing and sealing the cover.

#### REPAIRING THE INFLATABLE

A repair kit is included in case the inflatable is accidentally punctured, to repair:

- Locate the puncture - this can be done by inflating the inflatable and looking for air bubbles.
- Deflate the inflatable and make sure it is completely dry.
- Clean punctured area and dry the area.
- Using inflatable repair kit apply glue around punctured area.
- Use repair PVC sheet, cut so it is 5mm bigger around the punctured area.
- Stick the repair sheet on top of the punctured area.
- Let it dry for 2 hours.
- Inflate the inflatable and check there is no air leakage before use.

#### WARNING

**Lead acid battery generates explosive gasses. Use, recharge and store in a well ventilated area.**

#### BATTERY LIFE-CYCLE

THIS BATTERY TYPE IS DESIGNED TO BE RECHARGED UP TO 200 TIMES OR 2 YEARS AFTER PURCHASE, WHICHEVER COMES FIRST.

#### IMPORTANT

**ALWAYS RECHARGE THE BATTERY WITHIN 24 HOURS OF USE**  
**ALWAYS RECHARGE THE BATTERY EVERY 3 MONTHS AND AFTER USE**  
**DISPOSE OF THE BATTERY ACCORDING TO MUNICIPAL LAWS AND REGULATION**