

**DIESEL ENGINE
CONTROL UNIT**

DCU 205

- USER'S MANUAL -

AUTO-MASKIN A/s

N-2000 Lillestrøm, Norway

Tel: (+47) 64 84 52 00

Fax: (+47) 64 84 52 12

office@auto-maskin.no

TABLE OF CONTENTS

1. INTRODUCTION TO THE DCU 205	4
1.1. TYPE APPROVAL CERTIFICATES	4
2. TECHNICAL SPECIFICATION	5
2.1. IN GENERAL	5
2.2. FUSES.....	5
2.3. FRONT PANEL LAYOUT	6
3. BEFORE OPERATION	7
3.1. CONTROL INDICATOR	7
4. OPERATING THE CONTROL UNIT	8
4.1. START BUTTON	8
4.2. STOP BUTTON.....	8
4.3. STANDBY BUTTON.....	8
4.4. MANUAL BUTTON	9
4.5. RESET BUTTON.....	9
4.6. SIREN-OFF BUTTON.....	9
4.7. LAMP TEST BUTTON	9
4.8. HOUR COUNTER.....	9
5. ALARM CENTRE	10
5.1. IN GENERAL	10
5.2. NOT USED ALARMS	11
6. SHUTDOWN CENTRE.....	12
6.1. IN GENERAL	12
6.2. EMERGENCY AND HARBOUR GENERATOR SETS.....	13
6.3. OVERSPEED ADJUSTMENT.....	13
7. ADJUSTMENTS AND TIMER SETTINGS	14
7.1. FRONT PANEL TEXT LABELS.....	14
8. REMOTE CONTROL.....	15
8.1. MANUAL START AND STOP	15
8.2. AUTOMATIC START, DELAYED STOP	15
9. TROUBLE SHOOTING.....	16
10. WIRE CONNECTIONS TABLE	17
11. SCHEMATIC DIAGRAM.....	19

Document revisions

Date	Revision
January 1998	Release automatic resettable fuses
March 1997	Release v. 1.1
August 1996	Release v1.0
May 1996	Prototype
March 1996	Created

Approved by:

- *Det norske Veritas (DnV), certificate no. A-6246.*
- *Lloyd's Register of Shipping, certificate no. 96/00095.*



DnV logo

Lloyd's logo

Copyright © Auto-Maskin A/S, 1994 - 2001

Information given in this specification may change without prior notice.

This document should not be copied without permission from Auto-Maskin A/S.

Description:

Revision: august, 2001

User's Manual order no.: 05012

INTRODUCTION TO THE DCU 205

The Diesel Control Unit type **DCU 205**, is a unit for control and monitoring of marine diesel engines used as generator sets, main propulsion engines or pumping stations.

The unit covers functions such as manual start and stop, automatic start and stop, shutdowns and alarms for the diesel engine. Furthermore, it has built-in functions that make it easy to interface the unit to other control units onboard the ship.

DCU 205 is made up of two separate parts, mainly an alarm unit and a control unit. The alarm unit must be powered from the ships alarm centre, and the control unit from the start battery. The alarm unit will operate independently of the control unit.

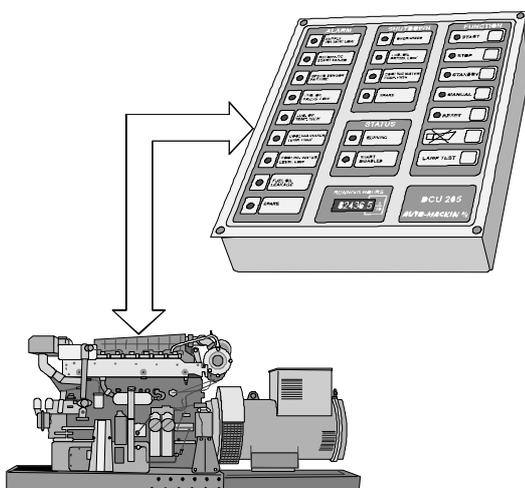

The front panel contains separate indication for alarms and shutdown functions, as well as buttons for start, stop, manual, standby, reset, siren off and lamp test. All *inputs* are electrically isolated with optocouplers, and the *relay outputs* can withstand 2 ampère load.

The unit is built for console mounting and requires little cabinet depth. It is delivered with a separate wire terminal unit which should be mounted in the cabinet. The cable between these units has snap-on connectors, which ensure quick and easy mounting and servicing.

The unit can be placed wherever suitable, or where it feels most natural to control and monitor the diesel engine. It can be fitted in the ship's control console or delivered in a steel enclosure for bulkhead mounting. The unit is robust and has a high degree of dust and water protection, and thus can be placed in the engine room.

Type approval certificates

The DCU 205 diesel control unit is CE-marked and type approved by the following classification bodies:

- *Det norske Veritas* (DnV), certificate no. A-6246.
- *Lloyd's Register of Shipping*, certificate no. 96/00095.

To obtain a copy of the certificates for your documentation, please contact your distributor, or *Auto-Maskin* directly.

TECHNICAL SPECIFICATION

In general

Supply	Voltage	Current consumption
To control unit, from startbattery	20-30VDC	Ca. 100mA
To alarm unit, from alarmcentre battery	20-30VDC	Ca. 50 mA
Output relay contact load	Max. 125V, 2A	
Operating ambient temperature	0 - 70°C	

DCU 205 unit

Cut-out dimensions	188 x 167mm (HxW)
Overall dimensions	204 x 182mm (HxW)
Centre distance, mounting holes	193 x 172mm (HxW)
Total depth	67mm
Holding screws	M3 - countersunk
Total weight	900 g
Front cabinet protection	IP55

Wire terminal card

Overall dimensions	40 x 211 x 83 mm (HxWxD)
Cable length (standard)	1.5 meters

Steel enclosure version

Overall dimensions	300 x 300 x 140mm (HxWxD)
Total weight (DCU 205 and enclosure)	4300 g
Degree of protection	IP44

Fuses

A total of 3 automatic resettable fuses are built into the unit. If the fuse breaks, it will reset itself in about 20 seconds.

Fuse	Purpose
F1, Circuit fuse	Protects the functions in the shutdown unit.
F2, Alarm fuse	Protects the functions in the alarm unit.
F4, Output fuse	Protects the start- and stop signal outputs to the diesel engine.

Table 0-Feil! Bryterargument er ikke angitt., The built-in automatic fuses

The fuses are of type Raychem Polyswitch ®, RXE040.

Front panel layout

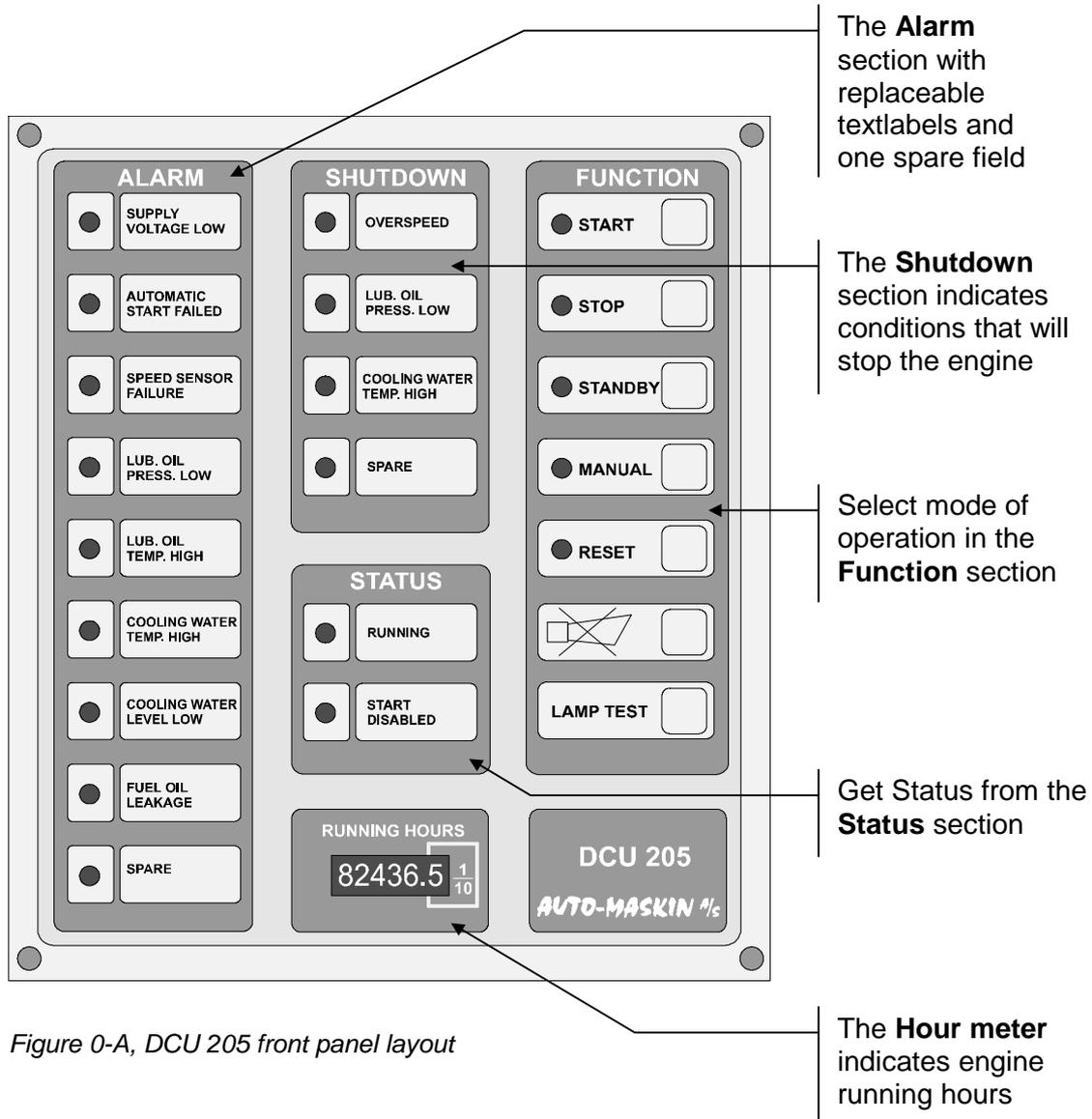

Figure 0-A, DCU 205 front panel layout

The frontpanel is divided into the four sections Alarm, Shutdown, Function and Status.

BEFORE OPERATION

Before switching on the Control Unit's 24VDC voltage supply, the following should be verified:

1. The switch for selecting the speed sensor type *must* be set to the right position according to the table below. The switch is located on the back panel.

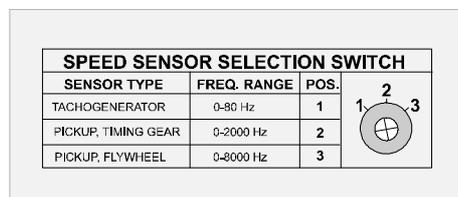

Speed sensor type	Frequency range	Switch position
Tachogenerator	0-80 Hz	1
Pick-up at the timing gear	0-2 kHz	2
Pick-up at the flywheel	0-8 kHz	3

Table 0-Feill! **Bokmerke er ikke definert.**, Selection of speed sensor type

2. Alarms not in use must be set in the OVERRIDE position. This is accomplished using DIP switch nos. 1-6, located on the back panel of the Control Unit. For further instructions, please see chapter 0.
3. Shutdown functions not in use should not be connected.
4. Verify all connections.
5. Check that the voltage supply is correct, positive 24VDC on terminal 1 and 39, negative on terminal 2 and 40. See chapter 0 and 0.
6. Make the necessary flywheel adjustments as noted under chapter 0.

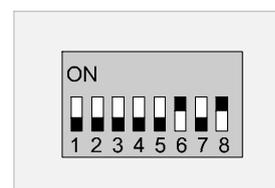

Control Indicator

Verify with the *Control Indicator* on the back panel, that a red and green lamp is flashing.

This indicates that the Alarm and Shutdown parts of the unit are activated and operating.

A constant light indicates malfunction.

One flashing and one black light normally indicates that power is applied to only one unit.



Flashing lights indicates the unit is operating:

*Red: Alarm unit
Green: Shutdown unit*

OPERATING THE CONTROL UNIT

The DCU 205 Control Unit is controlled using the seven pressure-sensitive push buttons on the front panel. For remote operation see chapter 0. The functions of these push buttons are discussed underneath.

Start button

For manual starting of the engine. The start solenoid is activated as long as the button is pressed, but is disabled when the RUNNING signal comes on. The RUNNING signal indicates that the engine has reached ignition speed.

The lamp in the start button area lights up when the button is pressed, when a remote start signal is given, or when the Control Unit receives an AUTOMATIC START signal in the STANDBY mode.

Stop button

The engine will stop immediately when voltage is applied to the stop solenoid connected to terminal no. 9. A brief press on the button is enough to activate the stop solenoid, which is then activated for approx. 50 seconds. The voltage on terminal no. 10, used for run solenoids or as feed voltage for electronic regulators, disappears at the same time.

The lamp in the STOP button will light during the stop holding time (the time terminal 9 has voltage), or if the engine has a DELAYED STOP command in STANDBY mode.

Standby button

Standby START

STANDBY is a situation where the Control Unit will try to start the engine three times if an external start signal, AUTOMATIC START, e.g. in the form of a blackout signal, is applied to terminals no. 21-22. The signal must be applied during the entire start sequence, approx. 45 sec., and may then be removed.

The lamp in the START button will remain on as long as the AUTOMATIC START signal is present. If the signal is removed, the start sequence will be aborted.

Each start attempt lasts 7 seconds followed by a 7-second pause (50% duty cycle). In addition, there is a 2-second delay before the first start. These delays are not adjustable.

If three start attempts have elapsed without a successful start of the diesel engine, the AUTOMATIC START FAILED alarm will be activated and the RESET lamp will come on to indicate that no further starts can be made until the operator has pressed the RESET button.

Standby STOP

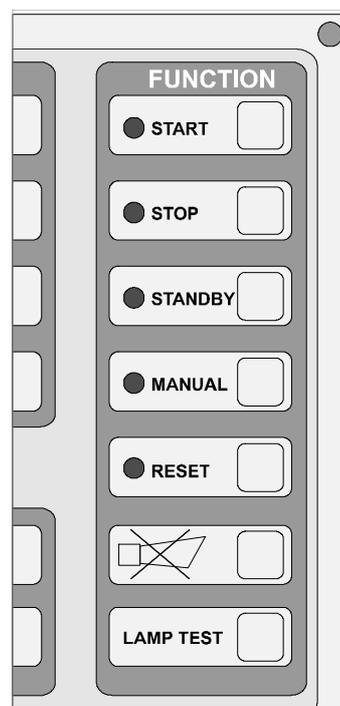

The engine may be given a delayed stop by applying the DELAYED STOP signal to terminals no. 21-23. The engine will then run the pre-set DELAYED STOP time, before the generator circuit breaker disconnect signal is given to terminals 35-36. The engine will then run at idle for a pre-set cooling time before finally stopping.

The STOP lamp will remain on as long as the DELAYED STOP signal is present, to indicate that the engine is in the stop cycle and about to stop.

If AUTOMATIC START and DELAYED STOP are applied simultaneously, priority is given to AUTOMATIC START.

A relay contact will be closed on Control Unit wire terminals no. 33-34 when the Unit is on STANDBY and START DISABLED lamp does NOT light up. These terminals can be used as an indication that the engine is ready for operation.

Manual button

This button is used to get the system out of STANDBY and into MANUAL. Once this is done, the lamp in the MANUAL area will light up and the automatic start and delayed stop inputs will be blocked.

Reset button

The RESET button is used to reset all alarms and shutdown functions. In addition, the STOP solenoid holding time will be reset. Alarms with flashing lamps will stop blinking but remain lit to indicate that the alarm has been reset but is still present. If the alarm switch is in normal position before RESET is pressed, the alarm light will turn off. The common alarm relay will return to normal position.

Siren-off button

The internal siren is activated by any alarm or shutdown. The siren is pulsing if caused by a shutdown situation and continuously if caused by an alarm.

The siren is turned off using the SIREN OFF button. This however, does not have any influence on the alarm conditions or relay outputs.

Lamp test button

Pressing this button will light all the lamps and activate the siren in the DCU 205.

Hour counter

The LCD counter shows the engine's total running hours, and runs when the RUNNING lamp is on.

This is indicated by the blinking hour glass symbol. When the engine is stopped the hour glass lamp remains visible but does not blink.

The meter has 1/10 of an hour resolution. It counts up to 99,999.9 hours and can only be reset by the supplier.



ALARM CENTRE

In general

The Control Unit has a total of 9 alarms. Three of these alarms are internally generated by the Control Unit, and the remaining 6 alarms are based on normally closed contacts from the controlled system, i.e., an open contact will set off an alarm. The three internal alarms are:

- Supply voltage low
- Automatic start failed, and
- Speed sensor failure

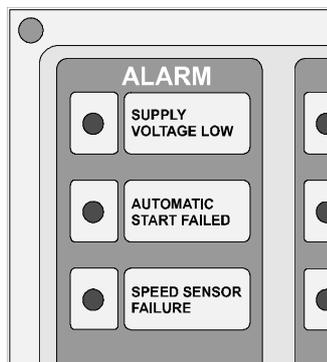

An activated alarm is indicated by its flashing lamp on the front panel. At the same time, the alarm will start the siren and activate the common alarm output relay.

The siren can be silenced by pressing the *Siren Off* button (marked with a symbol) located on the front panel.

The alarms are reset by pressing the RESET button. The common alarm relay will return to normal and the flashing lamp will stop flashing but remain lit. This indicates that the alarm has been acknowledged but is still present. The light turns off when the alarm actually disappears.

Supply voltage low

Alarm is given if the supply voltage drops below 23.5V. Interlocked in 60 sec. and while starting.

Failed automatic start

After 3 failed start attempts AUTOMATIC START FAILED and COMMON ALARM will appear.

Speed sensor failure

If the alarm is activated while the engine is running, it is either a broken wire connection or the signal might be too weak. Signal strength can be measured between wire terminals 3 and 4, and should be at least 2.0VAC.

If the actual alarm has disappeared before it has been acknowledged (reset), the flashing lamp and the common alarm will remain on until the RESET button has been pressed. All alarm inputs are delayed by 1.5 seconds.

The LUB. OIL PRESS. LOW and the extra SPARE alarm inputs are interlocked for 15 seconds after the engine has started, thus these alarms will not be triggered while the engine is stopped.

If the alarm is activated when the engine is at standstill, there is a problem with the oil pressure switch (shutdown switch) connected to terminal 5, since it is this signal that

interlocks the alarm. At the same time, this situation will activate the RUNNING signal and SPEED SENSOR FAIL.

Not used alarms

Alarms that are not in use *must* be overridden by switching the DIP switches located on the Control Unit's back panel to the **Override** position.

Otherwise, these inputs will give an alarm.

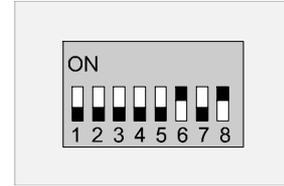

DIP switch no.	Wire terminal	Alarm	Up = Override Down = Normal
1	12	LUB. OIL PRESS. LOW	
2	13	LUB. OIL TEMP. HIGH	
3	14	COOLING WATER TEMP. HIGH	
4	15	COOLING WATER LEVEL LOW	
5	16	FUEL OIL LEAKAGE	
6	17	SPARE	

Table 0-Feil! Bokmerke er ikke definert., Overriding alarms that are not in use

Please take a moment to mark here which alarms (if any) should be overridden in this particular system.

SHUTDOWN CENTRE

In general

The Control Unit recognises up to 4 conditions that will activate engine shutdown. They are:

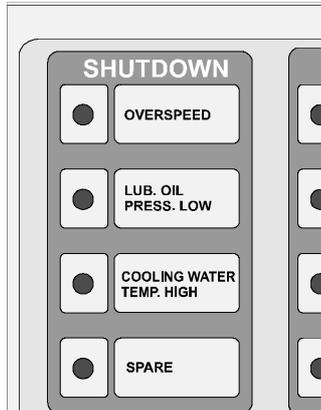

- Overspeed
- Lub. oil press. low NO
- Cooling water temp. high NO
- Spare NO

The Overspeed alarm is based upon the speed sensor frequency. The other three are normally open (NO) contact inputs.

The LUB. OIL PRESS LOW and SPARE alarms are excluded for 15 seconds after the engine has started, and are excluded if the engine is stopped.

An activated shutdown will flash its corresponding alarm lamp and start the siren. The siren can be silenced by pressing the Siren Off button located on the front panel, without resetting the alarm.

The shutdown sequence is as follows:

- The SHUTDOWN alarm output is activated.
- The Emergency Stop system output (wire terminal 11) is activated (OVERSPEED only).
- The stop solenoid is activated by applying voltage to terminal 9, and the engine stops. (The solenoid is activated for approximately 50 seconds).
- The run solenoid or electronic regulator on terminal 10 is deactivated.
- The STOP lamp located in the units FUNCTION area remain on as long as the stop solenoid is activated, or run solenoid is deactivated.
- The START DISABLED lamp activates.

Any Shutdown is reset by pressing the RESET button.

Emergency and harbour generator sets

When the generator set is used as a combined emergency and harbour generator set, it can be necessary to disable all shutdown functions, except overspeed, when used for emergency power.

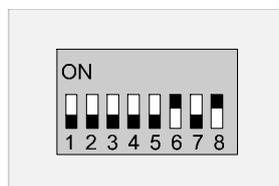

This function is enabled or disabled using DIP switch no. 7, located on the unit's back panel.

When the Control Unit is set in the STANDBY position and DIP switch no. 7 is in the OVERRIDE (ON) position, all the shutdown functions are disabled except for overspeed. If

the Control Unit is set in MANUAL, all the shutdown functions are enabled, regardless of the position of DIP switch no. 7.

The following table illustrates the situation.

Selected Function	DIP switch no. 7	Shutdown Functions
STANDBY	OFF	Enabled
STANDBY	ON	Disabled
MANUAL	Don't care	Enabled

Table 0-Feil! **Bokmerke er ikke definert.**, Disabling the Shutdown Functions in Standby mode

When shutdown function DISABLED is selected, the three lamps LUB. OIL LOW, COOLING WATER TEMP. HIGH and SPARE will flash simultaneously every 3 seconds, to indicate and remind of this particular selection.

Overspeed adjustment

The Control Unit activates alarm and shutdown when it detects engine overspeed. Here is how to adjust the overspeed setting to 15% above nominal speed.

1. Set DIP switch no. 8 to the OVERRIDE position.
2. Turn the OVERSPEED SETPOINT potentiometer a few revolutions clockwise.
3. For generator sets, run the engine at nominal speed. For main propulsion engines, run the engine at maximum speed
4. Now, slowly adjust the potentiometer anticlockwise, until the engine stops and the OVERSPEED lamp begins to blink.
5. Important!!! Turn DIP switch no. 8 back to the NORMAL position.

The overspeed set point has now been raised 15% above nominal or maximum speed.

ADJUSTMENTS AND TIMER SETTINGS

The table below shows the predefined time delays and the adjustable functions.

All adjustments are done on the back panel, see figure.

Use a fine screwdriver and a delicate hand when adjusting.

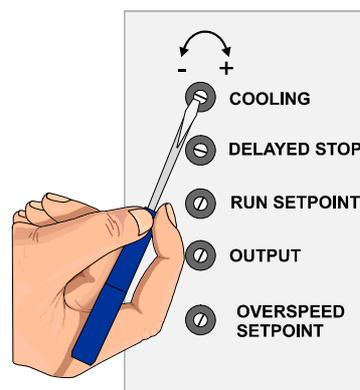

Function	Min.	Max.	Default value	Comment
Delayed automatic start	-	-	2 sec.	Not adjustable
Start and pause intervals during automatic start	-	-	7 sec.	Not adjustable
RUN signal	200	600	400 rev./min.	Adjustable from back panel
Overspeed (rev./min.)	1000	3000	15% above nominal speed	Adjustable from back panel. See chapter 0, Overspeed adjustment.
Stop solenoid, holding time	-	-	50 sec.	Not adjustable
Delay before disconnecting generator breaker	5	180	30 sec.	Adjustable from back panel
Cooling time	5	180	30 sec.	Adjustable from back panel
0 - 20 mA output for external rev. counter	2200	3000	20mA @ 2500 rev./min.	Adjustable from back panel
Monitoring delay	-	-	15 sec.	Not adjustable
Alarms delay	-	-	1.5 sec.	Not adjustable
Shutdown delay	-	-	1.5 sec.	Not adjustable

Table 0-Feil! **Bokmerke er ikke definert.**, Table of predefined time delays and adjustable functions.

Frontpanel text labels

The DCU 205 Control Unit is delivered with the most commonly used wording for alarms and shutdowns. However, there will be situations where other texts may be necessary.

New labels can be inserted by sliding the labels into place from the backside of the frontpanel.

REMOTE CONTROL

The Control Unit has wire terminals for two remote start and stop alternatives.

- Manual start and stop
- Automatic start and delayed stop

Manual start and stop

The Unit has terminals for remote start and stop. They work in the same way as the local push buttons.

Remote Start is connected to terminals no. 18-19. Remote Stop is connected to terminals no. 18-20.

Remember, a brief press on the stop button is enough to stop the engine.

Automatic start, delayed stop

When the Control Unit is set in the STANDBY mode, an internal start/stop program can be activated by means of external signals. Closed contact between terminals no. 21-22 activates start, and closed contact between terminals no. 21 and 23 activates stop.

For a more in-depth description of the above, see section 0, Standby, on page 8.

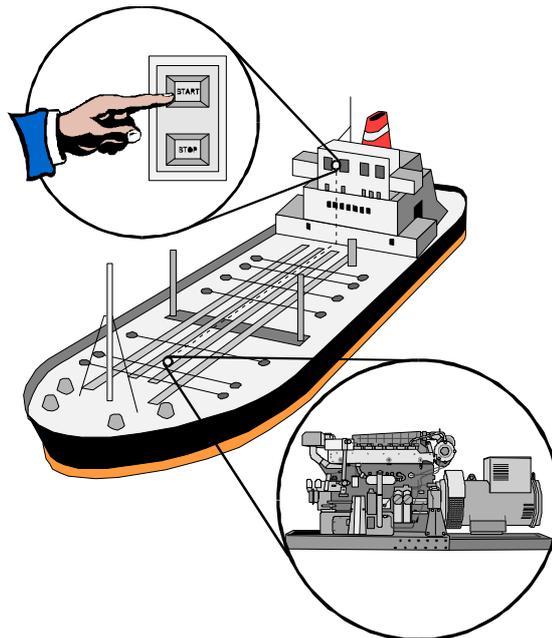

TROUBLE SHOOTING

Symptom	Possible cause	Action
1. The engine does not start manually.	<ol style="list-style-type: none"> Low battery capacity. Blown fuse. START DISABLED indication. RUNNING indication. 	<ol style="list-style-type: none"> Charge the battery, replace if defective. Wait approx. 20 seconds. RESET alarms. Check oil pressure switch and its connections, terminal no. 5.
2. The engine does not start automatically.	<ol style="list-style-type: none"> Low battery capacity. Control Unit not in STANDBY mode. Missing AUTOMATIC START signal. 	<ol style="list-style-type: none"> Charge the battery, replace if defective. Set the Unit in STANDBY mode. Check connections to terminals 21-22, or the signal source.
3. The RUNNING lamp is lit when the engine is stopped and the SPEED SENSOR FAILURE alarm is activated.	<ol style="list-style-type: none"> Lost connection between oil pressure shutdown switch connected to terminal 5. 	<ol style="list-style-type: none"> Check the oil pressure switch and its connections. There should be connection between terminals 2 (negative) and 5 on a stopped engine.
4. The SPEED SENSOR FAILURE alarm comes on while the engine is running.	<ol style="list-style-type: none"> Lost connection to terminal 3 and/or 4. Signal too weak. 	<ol style="list-style-type: none"> Check relevant cables. The signal must be at least 2.0VAC. Adjust or change tachogenerator.
5. The common alarm relay is activated without any indication on the control panel.	<ol style="list-style-type: none"> Blown fuse. Control Unit fault. 	<ol style="list-style-type: none"> Wait approx. 20 seconds. Check that the lamp marked CONTROL on the back panel of the unit is flashing. Turn power off and on again. If the lamp does not flash, contact distributor.
6. Simultaneous alarm for SUPPLY VOLTAGE LOW, SPEED SENSOR FAILURE and AUTOMATIC START FAILED.	<ol style="list-style-type: none"> The CIRCUIT fuse is blown. DCU 205 malfunction. 	<ol style="list-style-type: none"> Wait approx. 20 seconds. Contact distributor.

Table 0-Feil! Bokmerke er ikke definert., Trouble shooting table

Further, please verify the following:-

- Verify that the Control Unit has the correct voltage and polarity.
- Make sure the battery is connected in such a way that the Control Unit is sourced from the battery, *not* the battery charger only.

WIRE CONNECTIONS TABLE

This is a description of all wire connections to the DCU 205 unit. Maximum output relay contact load is 125V, 2A.

Terminal no.	In/Out	Comments
1, 2	In	24VDC mains, supplied from engine start battery. Also supplies the shutdown unit in the DCU 205. Positive on terminal 1, negative (0V) on terminal 2.
3, 4	In	From engine speed sensor. Use shielded cable and shield to battery negative (0V, terminal 2), not to ground. Signal strength must be 2-12VAC (pk-pk).
5, 6, 7	In	Shutdown inputs. 0V in gives shutdown after 1.5 seconds. Input 5 and 7 are interlocked 15 seconds after detected RUN signal.
8	Out	24VDC output for operating auxiliary start-motor relay. Protected with a 2 amp. fuse.
9	Out	24VDC output for operating auxiliary stop-solenoid relay. Protected with a 2 amp. fuse.
10	Out	24VDC output for operating auxiliary run-solenoid or electronic regulator relay. Voltage remains until a STOP command is given. Protected with a 2 amp. fuse.
11	Out	24VDC output for operating auxiliary emergency stop relay. Not activated during normal STOP. Protected with a 2 amp. fuse.
12, 13, 14, 15, 16, 17	In	Alarm inputs. If 0V is removed, alarm is given. Input 12 and 17 are interlocked 15 seconds after detected RUN signal.
18, 19	In	Remote START button.
18, 20	In	Remote STOP button.
21, 22	In	Input for automatic start when in STANDBY mode, e.g. blackout signal from main switchboard.
21, 23	In	Input for delayed stop, e.g. signal from load-dependent start/stop equipment.
24, 25, 26	Out	Voltage free change over contact for <i>Common alarm</i> . 24-25 is NC, 25-26 is NO. Relay deactivates in case of <i>Common alarm</i> .
27, 28, 29	Out	Voltage free change over contact indicating engine running. 27-28 is NC, 28-29 is NO. Relay activates when engine running.
30, 31, 32	Out	Voltage free change over contact indicating engine disabled. 30-31 is NC, 31-32 is NO. Relay activates if <i>Shutdown</i> is detected.
33, 34	Out	Voltage free contact (NO). If START DISABLED is not given, this indicates DCU 205 unit in STANDBY.
35, 36	Out	Voltage free contact (NO) for generator circuit disconnect. Closes at STOP or when stop delay time has elapsed during a delayed stop.
37, 38	Out	0-20mA output as a function of engine speed. Positive on 37, negative on 38. Use potmeter at the backpanel to calibrate. Use any correctly scaled 0-20mA meter.
39, 40	In	24VDC supply for the DCU 205 alarm section. Supply taken from the alarm centre battery. Positive on terminal 39, negative on terminal 40.

Table 0-Feil! Bokmerke er ikke definert., DCU 205 wiring connections

The terminal blocks are 2.5mm². All connections can be made using 0.5mm² cable, except to terminal 1-2 and 39-40 (power supply) where 1.5mm² should be used.

The diesel engine's terminal box **must** include auxiliary relays for start and stop, see drawing no. 1205-1, page 19.

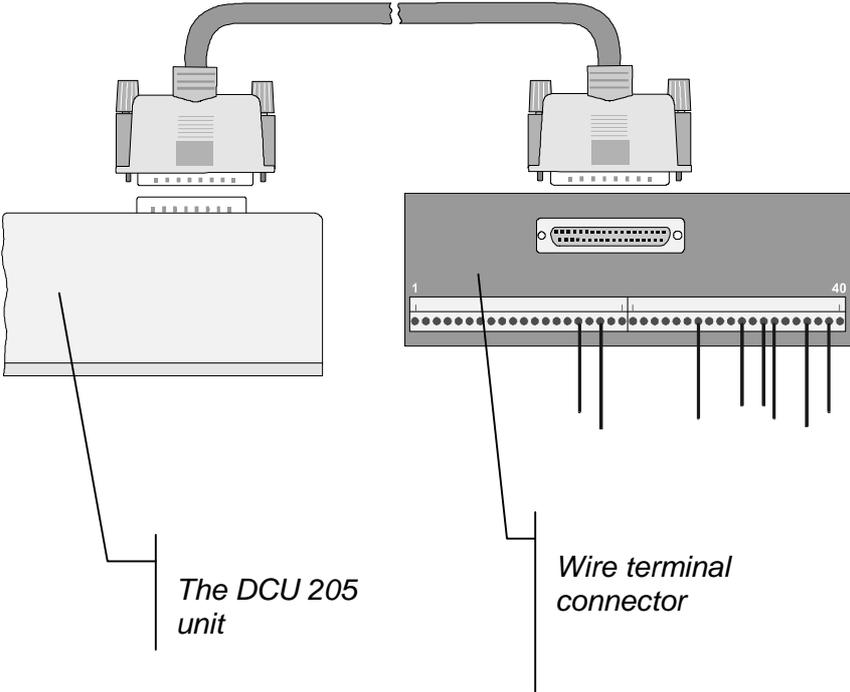

SCHEMATIC DIAGRAM

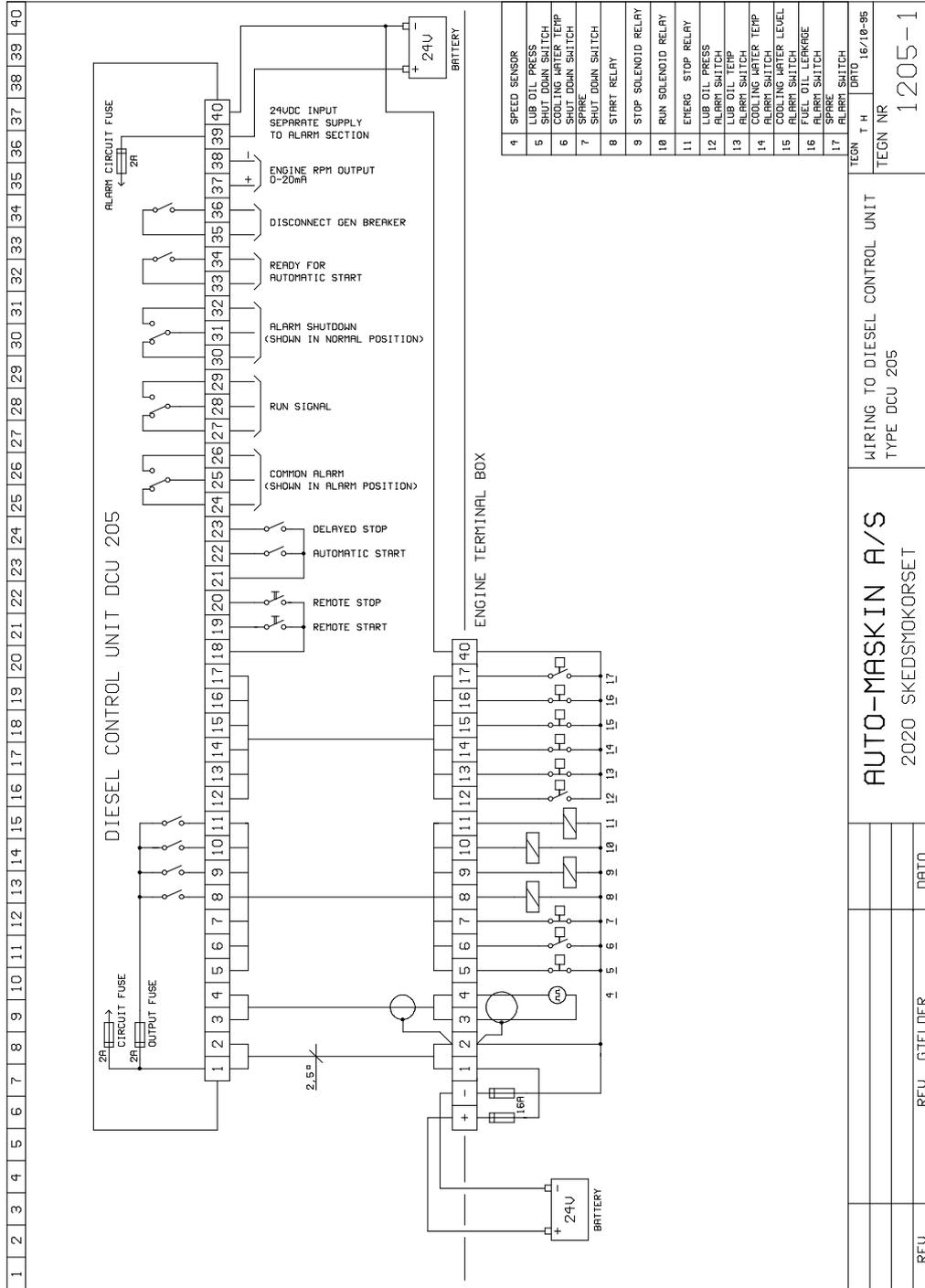

Figure 0-Feil! Bokmerke er ikke definert., DCU 205 wire connection diagram