

Ordering Replacement Parts

To order replacement parts, simply call our Customer Service Department toll-free at 1-800-999-3756, Monday through Friday, 6 a.m. until 6 p.m. Mountain Time (excluding holidays). To help us assist you, please be prepared to give the following information when calling:

1. The MODEL NUMBER of the product (WEBE13872).
2. The NAME of the product (WEIDER® 138 Weight Bench).
3. The SERIAL NUMBER of the product (see the front cover of this manual).
4. The KEY NUMBER and DESCRIPTION of the desired part(s) (see page 14 of this manual).

WEIDER®

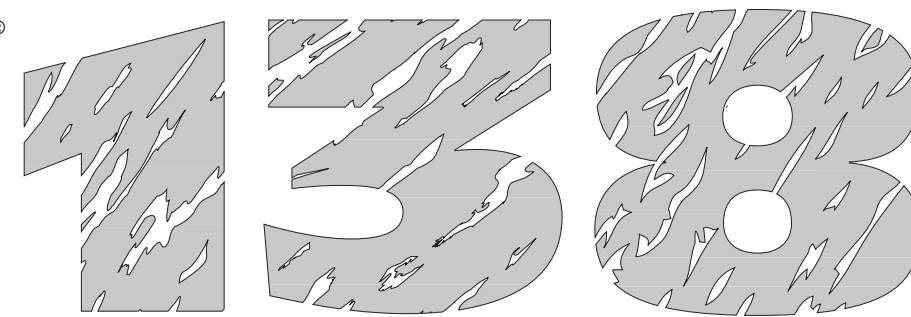

Model No. WEBE13872

Serial No. _____

Write the serial number in the space above for future reference.

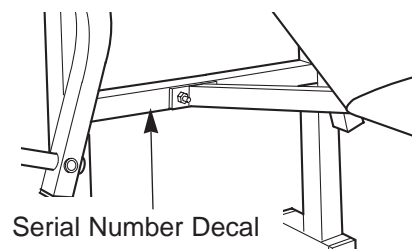

QUESTIONS?

As a manufacturer, we are committed to providing complete customer satisfaction. If you have questions, or find that there are missing or damaged parts, we will guarantee you complete satisfaction through direct assistance from our factory.

TO AVOID UNNECESSARY DELAYS, PLEASE CALL DIRECT TO OUR TOLL-FREE CUSTOMER HOT LINE. The trained technicians on our customer hot line will provide immediate assistance, free of charge to you.

CUSTOMER HOT LINE:
1-800-999-3756
Mon.–Fri., 6 a.m.–6 p.m. MST

VISIT OUR WEBSITE AT:
www.weiderfitness.com

CAUTION

Read all precautions and instructions in this manual before using this equipment. Save this manual for future reference.



USER'S MANUAL

Table of Contents

LIMITED WARRANTY	2
IMPORTANT PRECAUTIONS	3
BEFORE YOU BEGIN	4
PART IDENTIFICATION CHART	5
ASSEMBLY	6
ADJUSTING THE WEIGHT BENCH	10
EXERCISE GUIDELINES	11
MUSCLE CHART	12
PART LIST	14
EXPLODED DRAWING	15
ORDERING REPLACEMENT PARTSBack Cover

Limited Warranty

ICON Health & Fitness, Inc. (ICON), warrants this product to be free from defects in workmanship and material, under normal use and service conditions, for a period of ninety (90) days from the date of purchase. This warranty extends only to the original purchaser. ICON's obligation under this warranty is limited to replacing or repairing, at ICON's option, the product at one of its authorized service centers. All products for which warranty claim is made must be received by ICON at one of its authorized service centers with all freight and other transportation charges prepaid, accompanied by sufficient proof of purchase. All returns must be pre-authorized by ICON. This warranty does not extend to any product or damage to a product caused by or attributable to freight damage, abuse, misuse, improper or abnormal usage or repairs not provided by an ICON authorized service center, products used for commercial or rental purposes, or products used as store display models. No other warranty beyond that specifically set forth above is authorized by ICON.

ICON is not responsible or liable for indirect, special or consequential damages arising out of or in connection with the use or performance of the product or damages with respect to any economic loss, loss of property, loss of revenues or profits, loss of enjoyment or use, costs of removal, installation or other consequential damages of whatsoever nature. Some states do not allow the exclusion or limitation of incidental or consequential damages. Accordingly, the above limitation may not apply to you.

The warranty extended hereunder is in lieu of any and all other warranties and any implied warranties of merchantability or fitness for a particular purpose is limited in its scope and duration to the terms set forth herein. Some states do not allow limitations on how long an implied warranty lasts. Accordingly, the above limitation may not apply to you.

This warranty gives you specific legal rights. You may also have other rights which vary from state to state.

ICON HEALTH & FITNESS, INC., 1500 S. 1000 W., LOGAN, UT 84321-9813

WEIDER is a registered trademark of ICON Health & Fitness, Inc.

Exploded Drawing - Model No. WEBE13872

R0699A

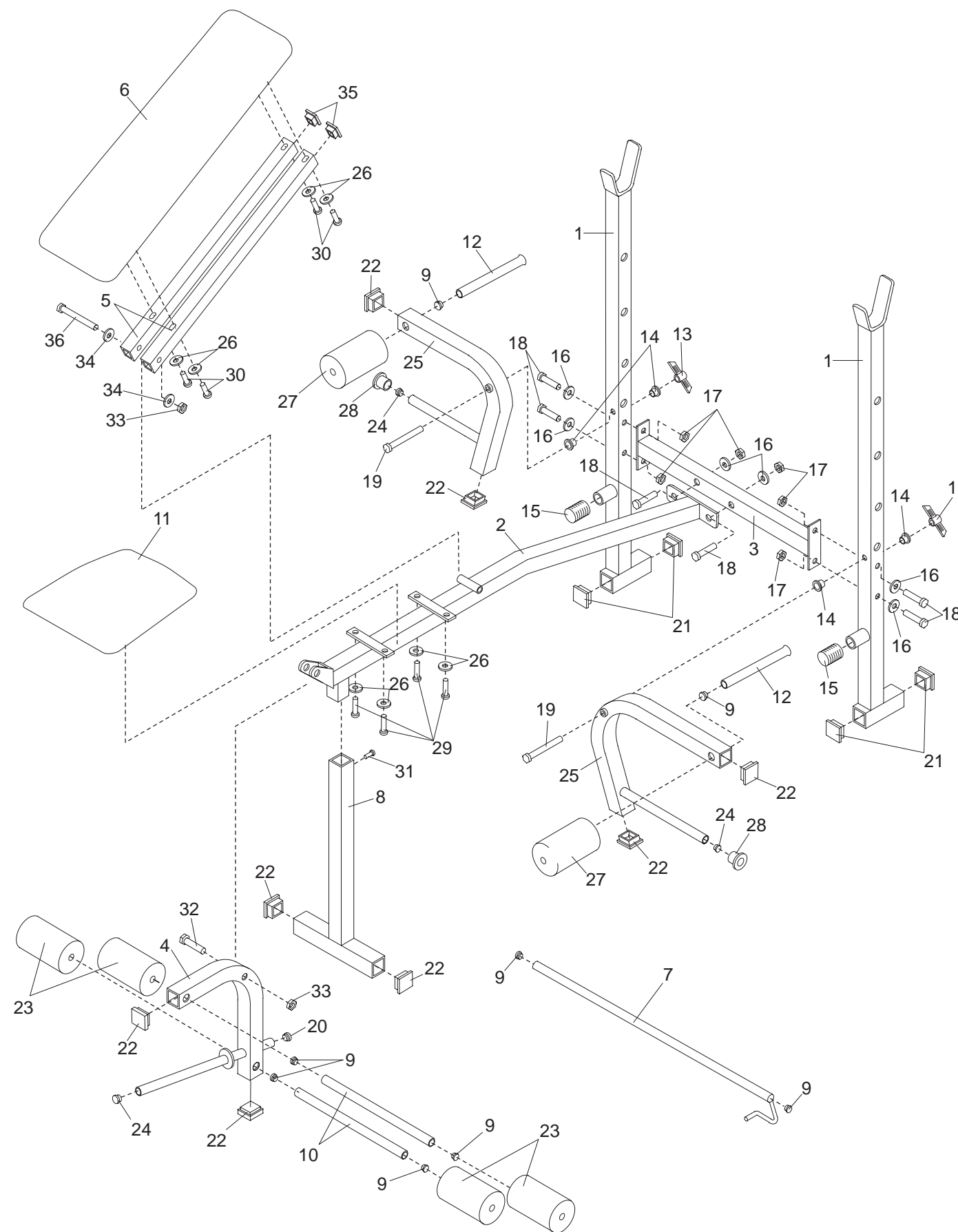

Part List - Model No. WEBE13872

R0699A

Key No.	Qty.	Description	Key No.	Qty.	Description
1	2	Upright	20	1	1" Angled Round Cap
2	1	Frame	21	4	38mm Square Inner Cap
3	1	Crossbar	22	8	30mm Square Inner Cap
4	1	Leg Lever	23	4	Long Foam Pad
5	2	Backrest Tube	24	3	1" Round Inner Cap
6	1	Backrest	25	2	Fly Arm
7	1	Support Rod	26	8	M6 Washer
8	1	Front Leg	27	2	Short Foam Pad
9	8	3/4" Round Inner Cap	28	2	Weight Stop
10	2	Long Pad Tube	29	4	M6 x 16mm Screw
11	1	Seat	30	4	M6 x 38mm Screw
12	2	Short Pad Tube	31	1	M10 x 19mm Bolt
13	2	Butterfly Knob	32	1	M10 x 58mm Bolt
14	4	Plastic Bushing	33	2	M10 Nylon Locknut
15	2	Fly Arm Stop	34	2	M10 Washer
16	6	M8 Washer	35	2	1" Square Inner Cap
17	6	M8 Nylon Locknut	36	1	M10 x 135mm Bolt
18	6	M8 x 57mm Bolt	#	1	User's Manual
19	2	M10 x 114mm Bolt	#	1	Exercise Poster

"#" Indicates a non-illustrated part. Specifications are subject to change without notice. See the back cover for information on ordering replacement parts.

Important Precautions

WARNING: To reduce the risk of serious injury, read the following important precautions before using the weight bench.

1. Read all instructions in this manual before using the weight bench.
2. Use the weight bench only as described in this manual.
3. It is the responsibility of the owner to ensure that all users of the weight bench are adequately informed of all precautions.
4. Use the weight bench only on a level surface. Cover the floor beneath the weight bench for protection.
5. Inspect and tighten all parts regularly; replace any worn parts immediately.
6. Keep children under the age of 12 and pets away from the weight bench at all times.
7. Always make sure there is an equal amount of weight (not included) on each side of your barbell (not included) when you are using it.
8. Do not use a barbell (not included) longer than five feet with the weight bench.
9. When you are using the leg lever, place a barbell (not included) with the same amount of weight on the weight rests to balance the bench.
10. Always wear athletic shoes for foot protection while exercising.
11. Keep hands and feet away from moving parts.
12. The weight bench is designed to support a maximum of 360 pounds, including the user, a barbell, and weights. Do not place more than 110 pounds, including a barbell and weights, on the weight rests; do not place more than 30 pounds on each fly arm; do not place more than 50 pounds on the leg lever.
13. When using the backrest in an inclined position, make sure that the support rod is inserted completely through the uprights, and that the support rod is turned to the locked position.
14. If you feel pain or dizziness at any time while exercising, stop immediately and begin cooling down.
15. The weight bench is intended for home use only. Do not use the weight bench in any commercial, rental or institutional setting.
16. **WARNING DECAL PLACEMENT:** The decal shown below has been placed on the weight bench. If the decal is missing, or if it is not legible, please call our Customer Service Department toll-free at 1-800-999-3756, Monday through Friday, 6 a.m. until 6 p.m. Mountain Time, to order a free replacement decal. Apply the replacement decal to the location shown.

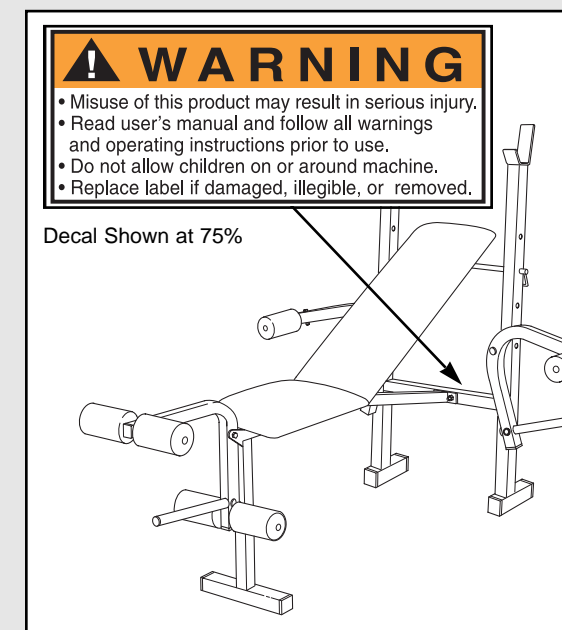

WARNING: Before beginning this or any exercise program, consult your physician. This is especially important for persons over the age of 35 or persons with pre-existing health problems. Read all instructions before using. ICON assumes no responsibility for personal injury or property damage sustained by or through the use of this product.

Before You Begin

Thank you for selecting the WEIDER® 138 Weight Bench. The versatile WEIDER® 138 Weight Bench is designed to be used with your own weight set (not included) to develop every major muscle group of the body. Whether your goal is a shapely figure, dramatic muscle size and strength, or a healthier cardiovascular system, the WEIDER® 138 Weight Bench will help you to achieve the specific results you want.

For your benefit, read this manual carefully before using the WEIDER® 138 Weight Bench. If you have additional questions, please call our Customer Service

Department toll-free at 1-800-999-3756, Monday through Friday, 6 a.m. until 6 p.m. Mountain Time (excluding holidays). To help us assist you, please note the product model number and serial number before calling. The model number is WEBE13872. The serial number can be found on a decal attached to the WEIDER® 138 Weight Bench (see the front cover of this manual).

Before reading further, please look at the drawing below and familiarize yourself with the parts that are labeled.

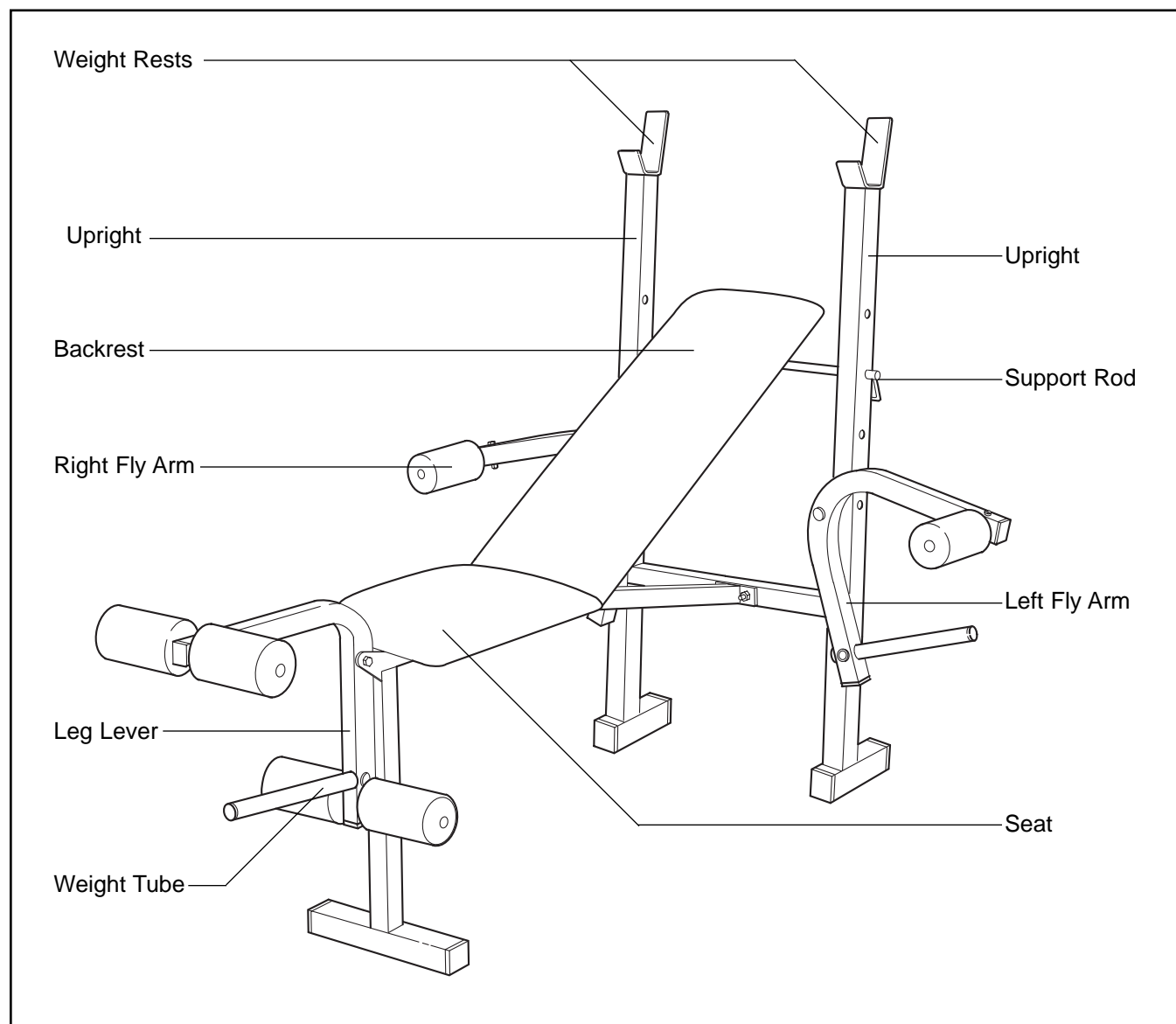

MONDAY	EXERCISE	WEIGHT	SETS	REPS
Date: / /				

TUESDAY AEROBIC EXERCISE

Date: / /

WEDNESDAY	EXERCISE	WEIGHT	SETS	REPS
Date: / /				

THURSDAY AEROBIC EXERCISE

Date: / /

FRIDAY	EXERCISE	WEIGHT	SETS	REPS
Date: / /				

Make photocopies of this page for scheduling and recording your workouts.

for 3 minutes after each set if you are doing a muscle building workout, 1 minute after each set if you are doing a toning workout, and 30 seconds after each set if you are doing a weight loss workout. Plan to spend the first couple of weeks familiarizing yourself with the equipment and learning the proper form for each exercise.

COOLING DOWN

End each workout with 5 to 10 minutes of stretching. Include stretches for both your arms and legs. Move slowly as you stretch—do not bounce. Ease into each stretch gradually and go only as far as you can without strain. Stretching at the end of each workout is very effective for increasing flexibility.

STAYING MOTIVATED

For motivation, keep a record of each workout. The chart on page 13 of this manual can be photocopied and used to schedule and record your workouts. List the date, exercises performed, weight, and numbers of sets and repetitions completed. Record your weight and key body measurements at the end of every month.

Remember, the key to achieving the greatest results is to make exercise a regular and enjoyable part of your everyday life.

Muscle Chart

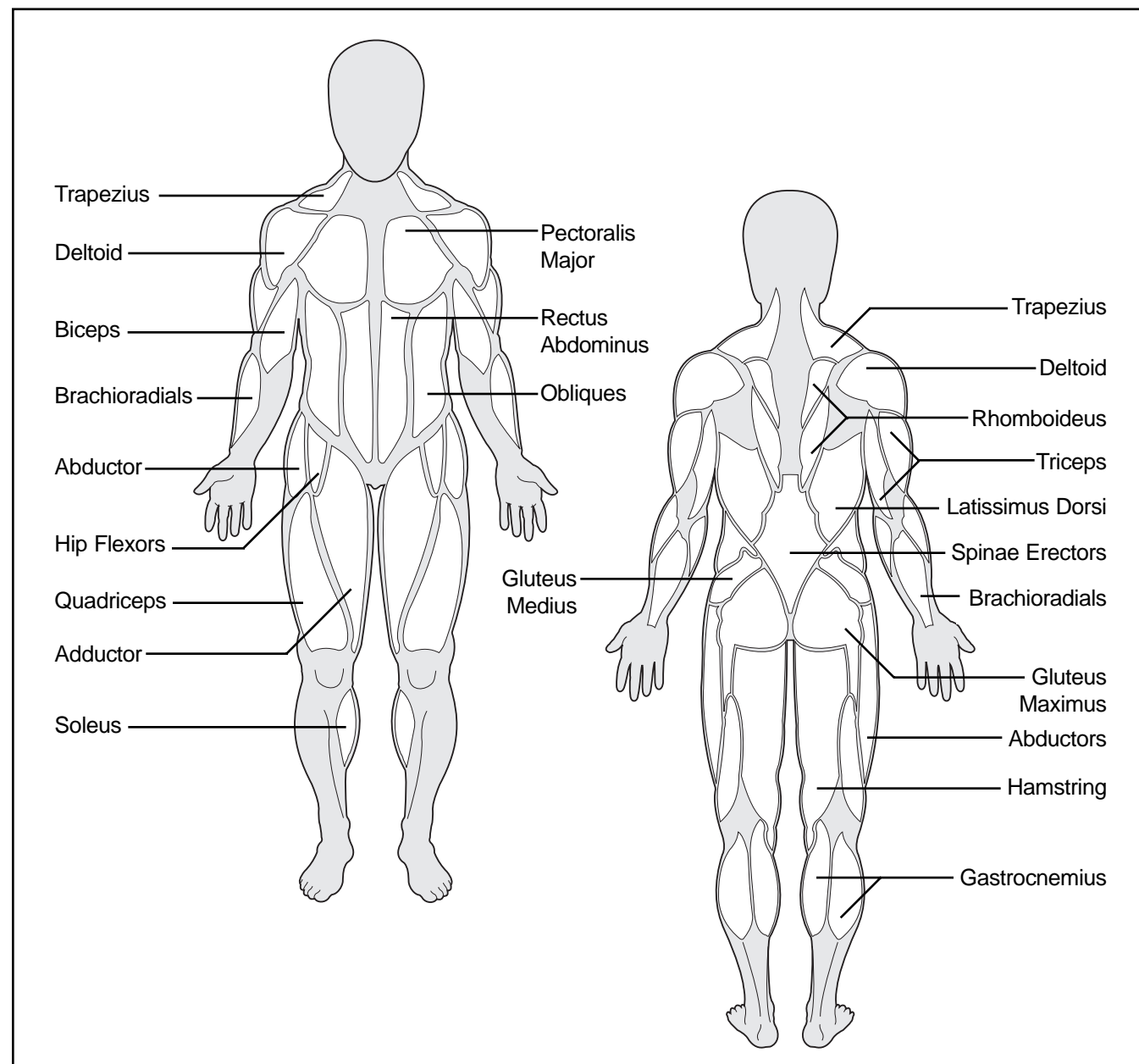

Part Identification Chart - Model No. WEBE13872

R0699A

This chart is provided to help you identify the small parts used in assembly. The number in parenthesis below each part refers to the key number of the part. The second number refers to the quantity needed for assembly. **Important: Some parts may have been pre-assembled for shipping purposes. If you cannot find a part in the parts bags, check to see if it has been pre-assembled.**

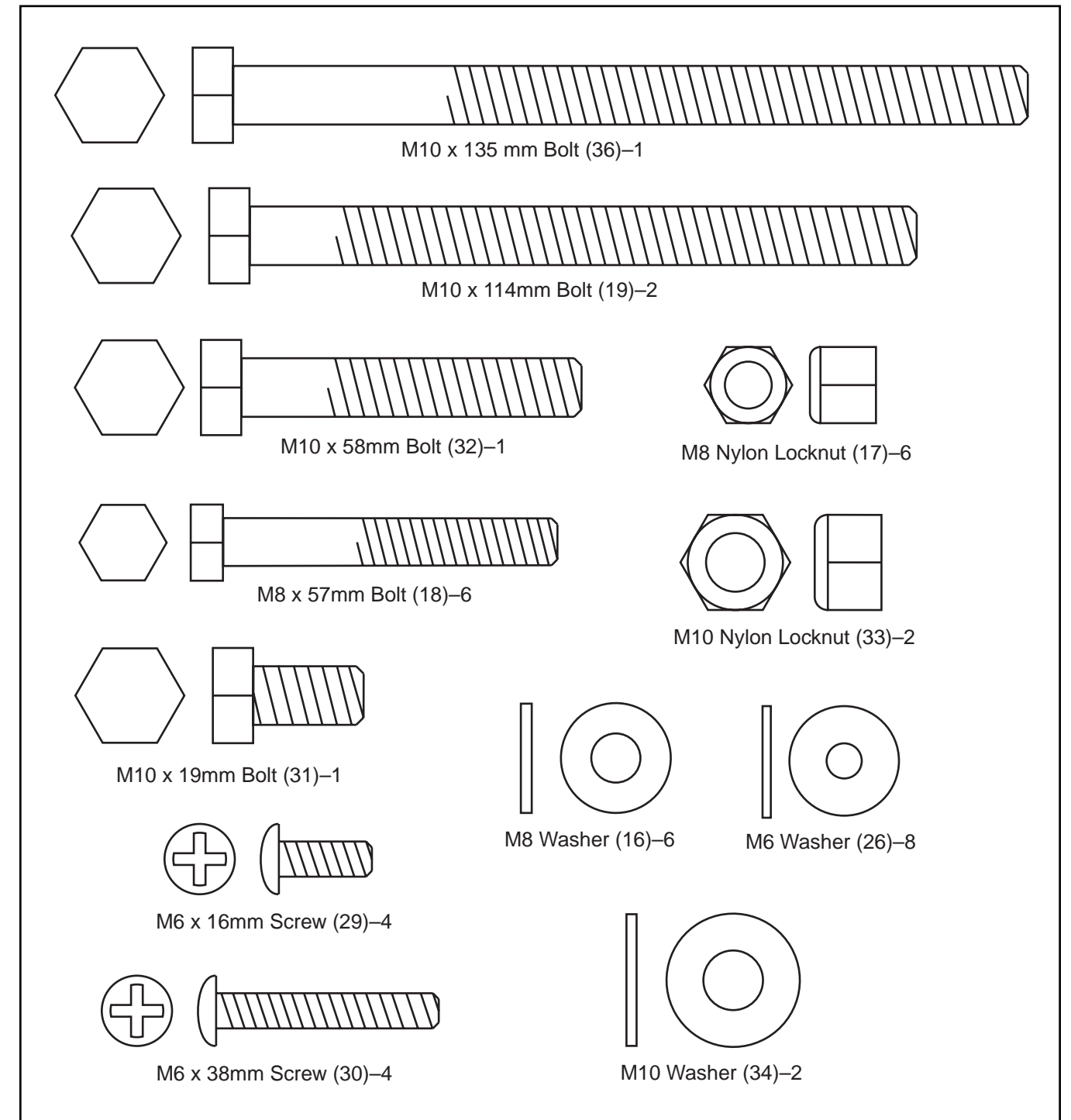



Assembly

Before beginning assembly, carefully read the following information and instructions:

- Place all parts of the weight bench in a cleared area and remove the packing materials; do not dispose of the packing materials until assembly is completed.
- Read each assembly step before you begin.
- For help identifying the small parts used in assembly, **use the PART IDENTIFICATION CHART on the previous page.** Note: Some small parts may have been pre-attached for shipping purposes. If a part is not in the parts bag, check to see if it has been pre-attached.
- Tighten all parts as you assemble them, unless instructed to do otherwise.

- As you assemble the weight bench, make sure that all parts are oriented as shown in the drawings.

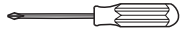
THE FOLLOWING TOOLS (NOT INCLUDED) ARE REQUIRED FOR ASSEMBLY:

- **Two (2) adjustable wrenches** 
- **One (1) phillips screwdriver** 
- **One (1) rubber mallet** 
- **Lubricant, such as grease or petroleum jelly, and soapy water will also be needed**

Assembly will be more convenient if you have the following tools: A socket set, a set of open-end or closed-end wrenches or a set of ratchet wrenches.

- 1. Before assembling this product, make sure you have read and understand the information in the box above.**

Tap two 38mm Square Inner Caps (21) into the open ends of the stabilizers on each Upright (1).

Attach the Crossbar (3) to the two Uprights (1) with four M8 x 57mm Bolts (18), four M8 Washers (16) and four M8 Nylon Locknuts (17). **Make sure the Crossbar (3) and both Uprights (1) are oriented as shown. The decal on the Crossbar must be facing up and the long bracket on the weight rests must be on the side shown here.**

- 2. Tap two 30mm Square Inner Caps (22) into the open ends of the stabilizer on the Front Leg (8).**

Attach the Front Leg (8) to the Frame (2) with the M10 x 19mm Bolt (31).

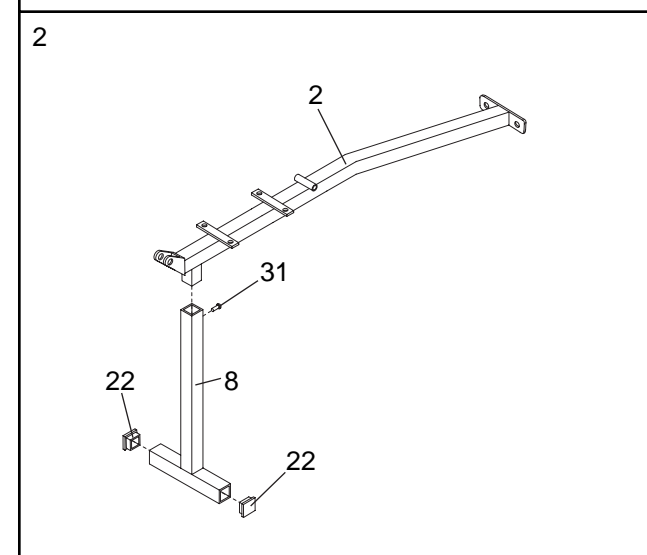
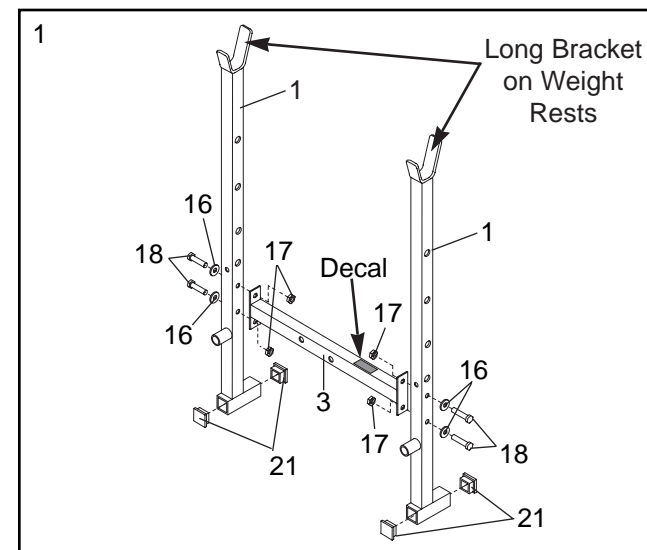

Exercise Guidelines

THE FOUR BASIC TYPES OF WORKOUTS

• Muscle Building

In order to increase the size and strength of your muscles, you must push your muscles to a high percentage of their capacity. You must also progressively increase the intensity of your exercise so that your muscles will continually adapt and grow. Each individual exercise can be tailored to the proper intensity level by changing the amount of weight used, or the number of repetitions or sets performed. (A "repetition" is one complete cycle of an exercise, such as one sit-up. A "set" is a series of repetitions performed consecutively.)

The proper amount of weight for each exercise depends upon the individual user. It is up to you to gauge your limits. Select the amount of weight that you think is right for you. Begin with 3 sets of 8 repetitions for each exercise that you perform. Rest for 3 minutes after each set. When you can complete 3 sets of 12 repetitions without difficulty, increase the amount of weight.

• Toning

To tone your muscles, you must push your muscles to a moderate percentage of their capacity. Select a moderate amount of weight and increase the number of repetitions in each set. Complete as many sets of 15 to 20 repetitions as possible without discomfort. Rest for 1 minute after each set. Work your muscles by completing more sets rather than by using high amounts of weight.

• Weight Loss

To lose weight, use a low amount of weight and increase the number of repetitions in each set. Exercise for 20 to 30 minutes, resting for a maximum of 30 seconds between sets.

• Cross Training

In the pursuit of a complete and well-balanced fitness program, many have found that cross training is the answer. We recommend that on Monday, Wednesday and Friday, you plan weight training workouts. On Tuesday and Thursday, plan 20 to 30 minutes of aerobic exercise, such as cycling, running or swimming. Rest from both weight training and aerobic exercise for at least one full day each week to give your body time to regenerate. By combining weight training with aerobic exercise, you can reshape and strengthen your body, plus develop a stronger heart and lungs.

PERSONALIZING YOUR EXERCISE PROGRAM

We have not specified an exact length of time for each workout, or a specific number of repetitions or sets for each exercise. It is very important to avoid overdoing it during the first few months of your exercise program, and to progress at your own pace. If you experience pain or dizziness at any time while exercising, stop immediately and begin to cool down. Find out what is wrong before continuing. Remember that adequate rest and a proper diet are also important.

WARMING UP

Begin each workout with 5 to 10 minutes of light stretching and exercise to warm up. Warming up prepares your body for exercise by increasing circulation, raising your body temperature and delivering more oxygen to your muscles.

WORKING OUT

Each workout should include 6 to 10 different exercises. Select exercises for every major muscle group, with emphasis on the areas that you want to develop the most. To give balance and variety to your workouts, vary the exercises from workout to workout.

Schedule your workouts for the time of day when your energy level is the highest. Each workout should be followed by at least one day of rest. Once you find the schedule that is right for you, stick with it.

EXERCISE FORM

In order to obtain the greatest benefits from exercising, it is essential to maintain proper form.

Maintaining proper form means moving through the full range of motion for each exercise, and moving only the appropriate parts of the body. Exercising in an uncontrolled manner will leave you feeling exhausted. On the exercise poster accompanying this manual, you will find photographs showing the correct form for several exercises. A description of each exercise is also provided, along with a list of the muscles affected. Refer to the muscle chart on page 12 to find the locations of the muscles.

The repetitions in each set should be performed smoothly and without pausing. The exertion stage of each repetition should last about half as long as the return stage. Proper breathing is important. Exhale during the exertion stage of each repetition and inhale during the return stroke; never hold your breath. Rest

Adjusting the Weight Bench

The weight bench is designed to be used with your own weight set (not included). The steps below explain how the weight bench can be adjusted. See EXERCISE GUIDELINES on page 11 for important exercise information and refer to the accompanying exercise poster to see the correct form for each exercise. Refer also to the exercise information accompanying your weight set (not included) for additional exercises.

Inspect and tighten all parts each time you use the weight bench. Replace any worn parts immediately. The weight bench can be cleaned with a damp cloth and a mild, non-abrasive detergent. Do not use solvents.

ADJUSTING THE BACKREST

The Backrest (6) can be used in a level position, three inclined positions or a declined position. To use the Backrest in a **declined position**, remove the Support Rod (7) and lay the Backrest on the Frame (2).

To use the Backrest (6) in an **inclined position**, first lift the Backrest. Insert the Support Rod (7) through one of the three upper sets of holes in the Uprights (1). Rotate the Support Rod to the locked position, so the locking pin is wrapped around the Upright. Lay the Backrest on the Support Rod.

To use the Backrest (6) in a **level position**, insert the Support Rod (7) through the lowest set of holes in the Uprights (1). Rotate the Support Rod to the locked position, so the locking pin is wrapped around the Upright. Lay the Backrest on the Support Rod.

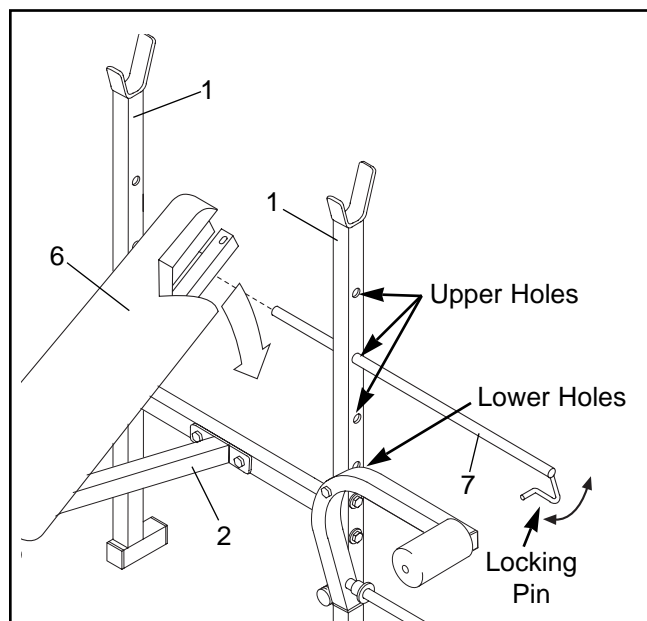

ATTACHING WEIGHTS

To use the Leg Lever (4), slide the desired weights (not included) onto the weight tube. **WARNING: Do not place more than 50 pounds on the Leg Lever.**

CAUTION: When you are using the leg lever, place a barbell (not included) with the same amount of weight on the weight rests to balance the bench.

To use the Fly Arms (25), make sure there is a Weight Stop (28) on each weight tube. Next, slide the desired weights (not included) onto the weight tubes. **WARNING: Do not place more than 30 pounds on each Arm.**

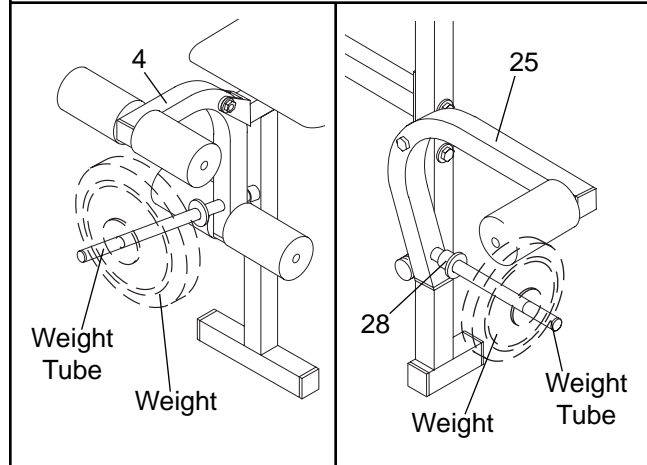

REMOVING AND ATTACHING THE FLY ARMS

Some exercises are easier to perform if the Fly Arms (25) are removed from the weight bench. To remove the Fly Arms, remove the Butterfly Knob (13) and the M10 x 114mm Bolt (19) from each Fly Arm and Upright (1). Place the Fly Arms in a safe place.

To re-attach the Fly Arms (25), align the holes in the Fly Arms with the holes in the Uprights (1). Insert the M10 x 114mm Bolts (19) through the Fly Arms and Uprights. Tighten the Butterfly Knobs (13) onto the Bolts.

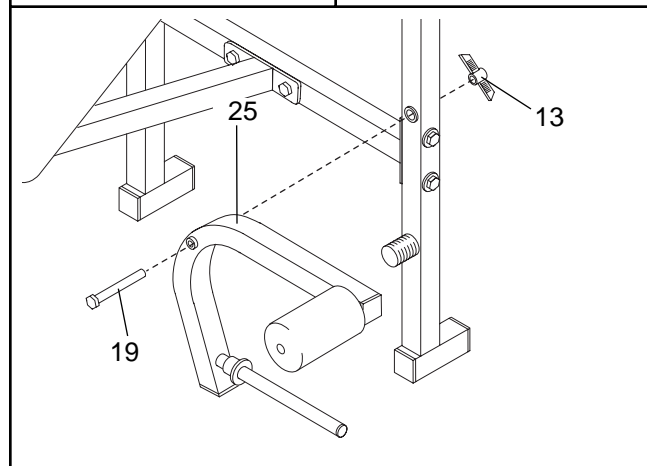

3. Make sure the Uprights (1) are oriented as shown. The long bracket on the weight rests must be on the side indicated. Attach the Frame (2) to the Crossbar (3) with two M8 x 57mm Bolts (18), two M8 Washers (16) and two M8 Nylon Locknuts (17).

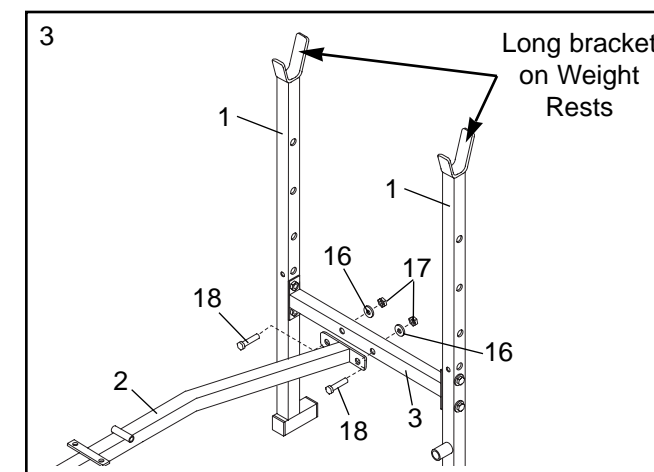

4. Tap a 30mm Square Inner Cap (22) into each open end of the Leg Lever (4).

Tap a 1" Round Inner Cap (24) into the indicated end of the weight tube. Tap the 1" Angled Round Cap (20) onto the other end of the weight tube.

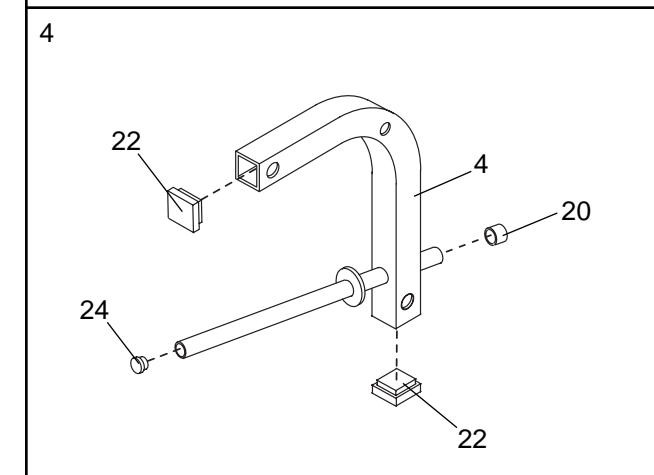

5. Lubricate the M10 x 58mm Bolt (32). Attach the Leg Lever (4) to the bracket on the Frame (2) with the Bolt and the M10 Nylon Locknut (33).

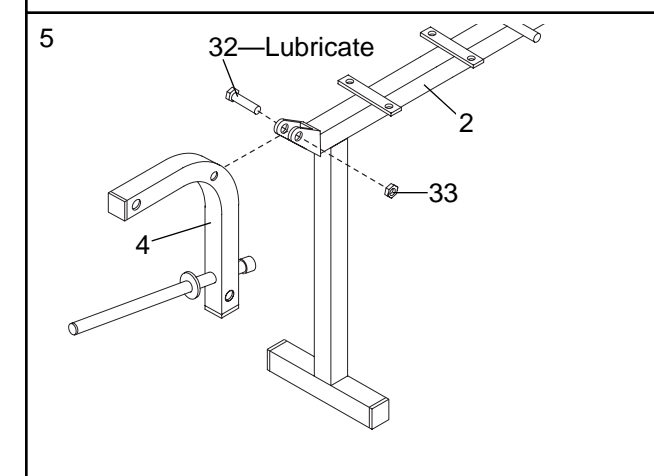

6. Tap two 3/4" Round Inner Caps (9) into each Long Pad Tube (10). Insert the Pad Tubes through the holes in the Leg Lever (4). Slide two Long Foam Pads (23) onto each Pad Tube.

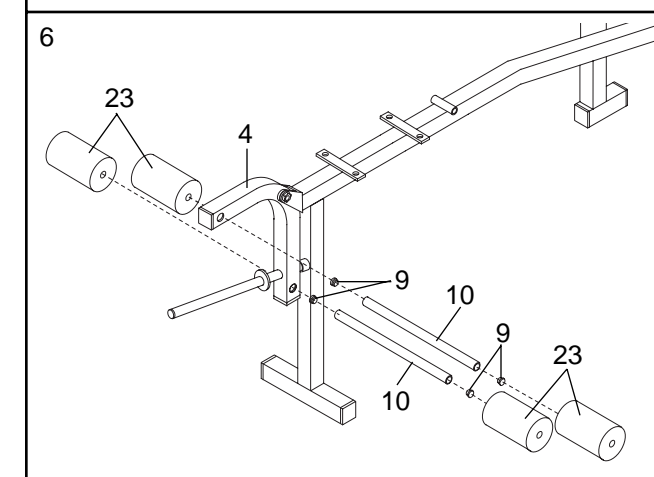

7. Tap a 1" Square Inner Cap (35) into the indicated ends of the two Backrest Tubes (5).

Attach each Backrest Tube (5) to the Backrest (6) with two M6 x 38mm Screws (30) and two M6 Washers (26). **Note: Do not tighten the Screws fully.**

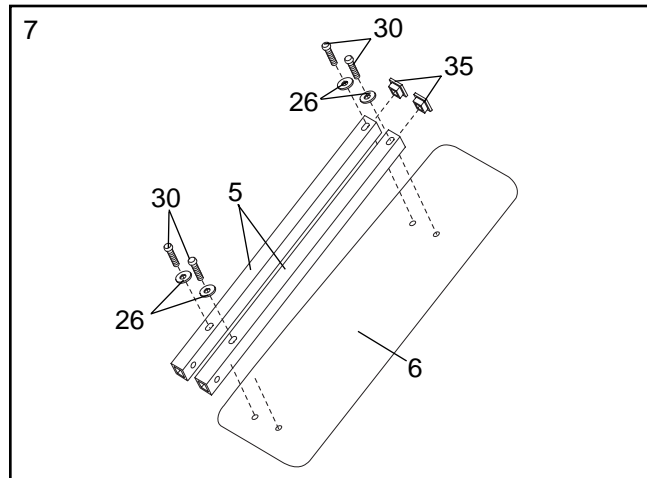

8. Tap a 3/4" Round Inner Cap (9) into each end of the Support Rod (7). Insert the Support Rod through one of the three upper sets of holes in the Uprights (1). Rotate the Support Rod to the locked position, with the locking pin wrapped around the Upright.

Lubricate the M10 x 135mm Bolt (36). Attach the Backrest Tubes (5) to the welded tube on the Frame (2) with the Bolt, two M10 Washers (34) and an M10 Nylon Locknut (33) **Fully tighten all four M6 x 38mm Screws (30) used in step 7.**

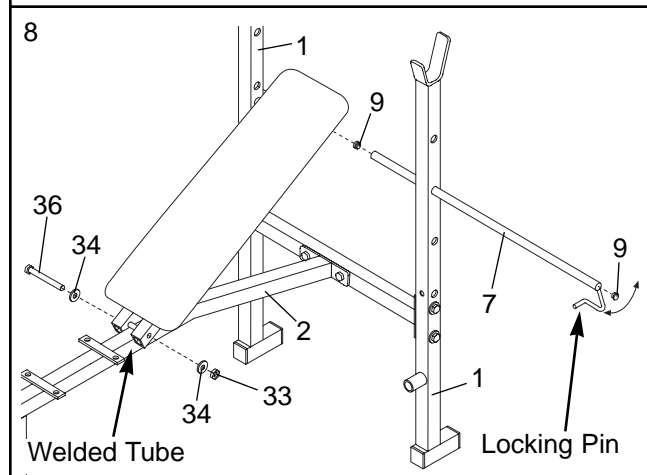

9. Attach the Seat (11) to the brackets on the Frame (2) with four M6 x 16mm Screws (29) and four M6 Washers (26).

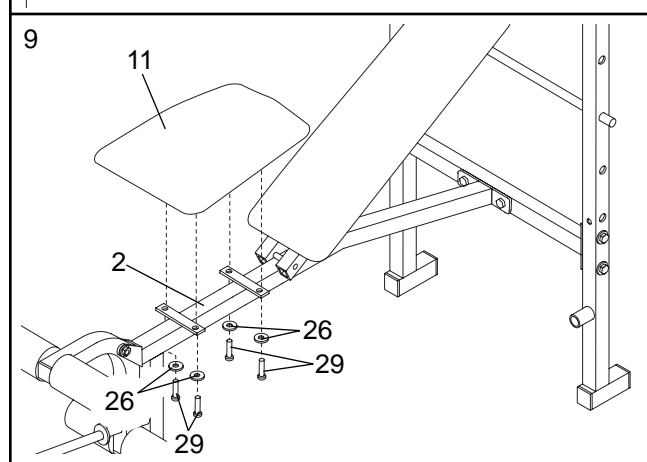

10. Tap a Fly Arm Stop (15) onto the welded tube on each Upright (1).

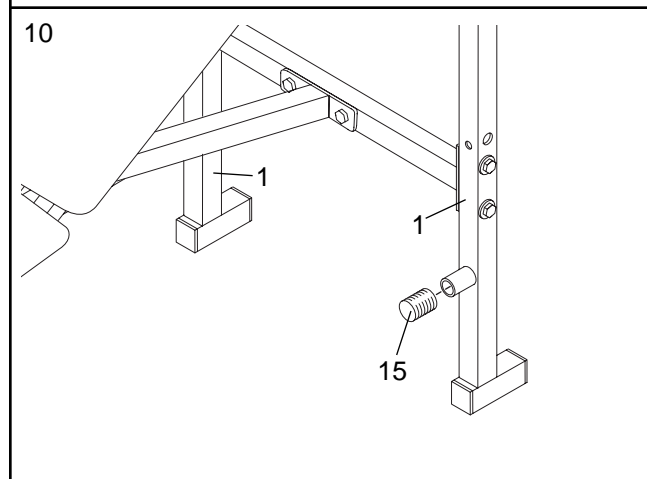

11. Tap two 30mm Square Inner Caps (22) into each open end of the left Fly Arm (25). Push a 1" Round Inner Cap (24) into the end of the weight tube. Slide a Weight Stop (28) onto the weight tube.

Assemble the right Fly Arm (not shown) in the same manner.

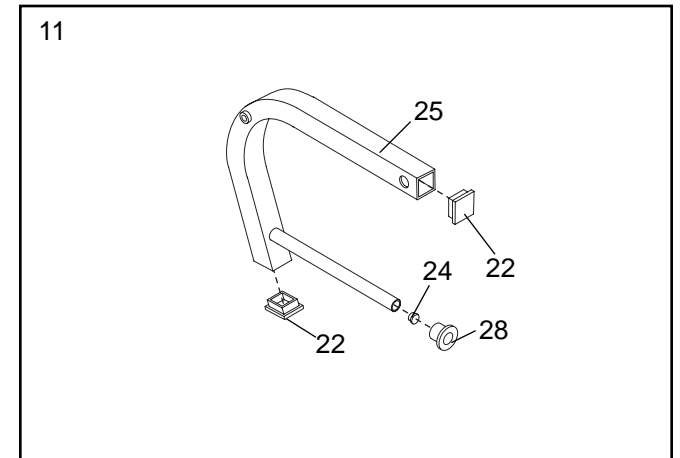

12. Press two Plastic Bushings (14) into the indicated holes in the left Upright (1). Attach the left Fly Arm (25) to the Upright using an M10 x 114mm Bolt (19) and a Butterfly Knob (13). Make sure the Fly Arm is on the outside of the Fly Arm Stop (15).

Attach the right Fly Arm (not shown) to the right Upright (not shown) in the same manner.

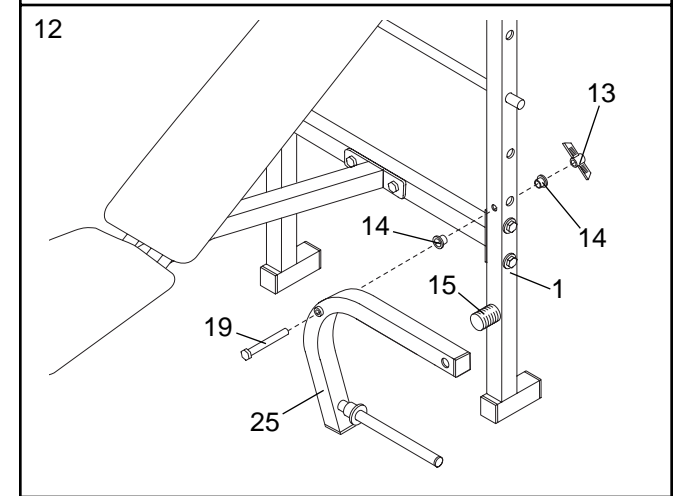

13. Push a 3/4" Round Inner Cap (9) into the end of a Short Pad Tube (12). Slide the Short Pad Tube through the indicated hole in the left Fly Arm (25), as shown. Push a Short Foam Pad (27) onto the Pad Tube.

Repeat this step for the right Fly Arm (not shown).

14. **Make sure all parts are properly tightened before you use the weight bench. The use of all remaining parts will be explained in Adjusting the Weight Bench starting on the next page.**

