

# **AutoMax Processor Module**

M/N 57C430A

M/N 57C431

M/N 57C435

---

Instruction Manual J-3650-6

---

**RELIANCE  
ELECTRIC** 

The information in this user's manual is subject to change without notice.

**WARNING**

**ONLY QUALIFIED PERSONNEL FAMILIAR WITH THE CONSTRUCTION AND OPERATION OF THE CONTROLLED EQUIPMENT SHOULD INSTALL, ADJUST, OPERATE, OR SERVICE THIS EQUIPMENT. READ AND UNDERSTAND THIS MANUAL AND OTHER MANUALS APPLICABLE TO YOUR INSTALLATION. FAILURE TO OBSERVE THIS PRECAUTION COULD RESULT IN BODILY INJURY.**

**WARNING**

**INSERTING OR REMOVING THIS MODULE OR ITS CONNECTING CABLES MAY RESULT IN UNEXPECTED MACHINE MOTION. POWER TO THE MACHINE SHOULD BE TURNED OFF BEFORE INSERTING OR REMOVING THE MODULE OR ITS CONNECTING CABLES. FAILURE TO OBSERVE THESE PRECAUTIONS COULD RESULT IN BODILY INJURY.**

**CAUTION:** This module contains static-sensitive components. Careless handling can cause severe damage. Do not touch the connectors on the back of the module. When not in use, the module should be stored in an anti-static bag. The plastic cover should not be removed. Failure to observe this precaution could result in damage to or destruction of equipment.

Motorola™ 68010 and 68020 are trademarks of Motorola, Inc.

A-B™ is a trademark of Allen-Bradley Corporation.

IBM™ is a trademark of International Business Machines, Inc.

Modbus™ is a trademark of Gould, Inc.

Multibus™ is a trademark of Intel Corporation.

Reliance® and AutoMax® are registered trademarks of Reliance Electric Company or its subsidiaries.

# Table of Contents

<b>1.0</b>	<b>Introduction</b>	<b>1-1</b>
1.1	Additional Information	1-2
1.2	Related Hardware and Software	1-2
1.3	Compatibility with Earlier Versions	1-3
<b>2.0</b>	<b>Mechanical/Electrical Description</b>	<b>2-1</b>
2.1	Mechanical Description	2-1
2.2	Electrical Description	2-3
<b>3.0</b>	<b>Installation</b>	<b>3-1</b>
3.1	Wiring	3-1
3.2	Initial Installation	3-1
3.3	Module Replacement	3-3
3.4	On-Board Battery Replacement	3-4
3.5	Processor Module Diagnostics	3-5
3.5.1	Power-Up Diagnostics	3-5
3.5.2	Run-Time Diagnostics	3-5
<b>4.0</b>	<b>Programming</b>	<b>4-1</b>
4.1	Loading the Operating System	4-1
4.2	Accessing Processor Ports	4-3
4.3	Programmable Tick Rate	4-4
4.4	Restrictions	4-5
4.4.1	Number of Processors in a Rack	4-5
4.4.2	Rack Slot Restrictions	4-5
4.4.3	Use with the DCS5000 M/N 57C407 Processor Module or the 57C430 Processor Module	4-5
4.4.4	Ethernet Commands	4-5
<b>5.0</b>	<b>Diagnostics and Troubleshooting</b>	<b>5-1</b>
5.1	The “OK” LED Is Off	5-1
5.2	The “BAT. OK” LED Is Off	5-2
5.3	BUS ERROR	5-3
5.4	Common Memory Module Diagnostic Failure	5-6
5.5	Incorrect Data	5-7

# Appendices

<b>Appendix A</b>	
Technical Specifications .....	A-1
<b>Appendix B</b>	
Module Block Diagram .....	B-1
<b>Appendix C</b>	
Connecting the AutoMax Processor to the Personal Computer . . . .	C-1
<b>Appendix D</b>	
Diagnostic LED Error Codes .....	D-1
<b>Appendix E</b>	
Run Time LED Error Codes .....	E-1
<b>Appendix F</b>	
Using Modems with AutoMax Systems .....	F-1

# List of Figures

Figure 2.1 - Processor Module Faceplate .....	2-2
Figure 2.2 - Typical RS-232C Circuit .....	2-3
Figure 3.1 - Rack Slot Numbers .....	3-2
Figure 4.1 - Specifying the SETUP Parameter in an OPEN Statement ...	4-4



# 1.0 INTRODUCTION

The products described in this instruction manual are manufactured by Reliance Electric Industrial Company. The Automax Processor module plugs into the backplane of an AutoMax rack and executes application programs which in turn control other AutoMax modules in the system. The M/N 57C430A and 57C431 Processor modules are based on the Motorola 68010 16-bit microprocessor. The M/N 57C435 Processor module is based on the Motorola 68020 32-bit microprocessor. All three Processors are programmed using three high-level application languages: BASIC, Control Block and Ladder Logic.

The Processor modules have the following memory/speed configurations:

<b>Model</b>	<b>CPU Speed</b>	<b>Memory</b>
M/N 57C430A AutoMax 6010 Processor module	8 mHz	256K Parity RAM
M/N 57C431 AutoMax 6011 Processor module	8 mHz	512K Parity RAM
M/N 57C435 AutoMax 7010 Processor module	25 mHz	512K Parity RAM

Up to four AutoMax Processor modules can be used in a rack (M/N 57C331, M/N 57C332 or M/N 57C334) to increase the processing capability and the total memory available for application tasks. M/N 57C430A, 57C431, and 57C435 Processors can be used in the same rack. M/N 57C430A Processors make 135K-150K available for application programs depending on which operating system is loaded onto the Processor. M/N 57C431 and 57C435 Processors make 300K available for application programs, regardless of which operating system is loaded onto the Processor. Multiple Processors in a rack require the use of the Common Memory module (M/N 57C413 or M/N 57C423) for bus arbitration and sharing of system-wide information. The Common Memory module can also be used with a single Processor module to make available an additional 128K bytes of memory for common, i.e., system-wide, variables.

An on-board lithium battery and a super-capacitor protect the Processor module from power failures. Should the system lose power, the on-board battery of the M/N 57C430A or 57C431 Processor can maintain the contents of RAM for a minimum of 42 days. The onboard battery of the M/N 57C435 Processor can maintain the contents of RAM for a minimum of 186 days.

The remainder of this manual describes the functions and specifications of the module. It also includes a detailed overview of installation and servicing procedures.

The thick black bar shown at the right-hand margin of this page will be used throughout this instruction manual to signify new or revised text or figures.

## 1.1 Additional Information

You should be familiar with the following related publications to use the AutoMax Processor correctly:

- J-3616-1 Kermit Communications Software Instruction Manual
- J-3618 Norton Editor Instruction Manual
- J-3636 Common Memory Module Instruction Manual
- J-3649 AutoMax Configuration Task Manual
- J-3675 AutoMax Enhanced Basic Language Instruction Manual
- J-3676 AutoMax Control Block Language Instruction Manual
- J-3677 AutoMax Ladder Logic Language Instruction Manual
- J2-3093 AutoMax Enhanced Ladder Editor
- J2-3094 AutoMax Enhanced Ladder Language Reference
- Your ReSource AutoMax Executive Software Loading Instructions
- Your ReSource AutoMax Programming Executive Instruction Manual
- IEEE 518 Guide for The Installation of Electrical Equipment to Minimize Electrical Noise Inputs to Controllers
- Your personal computer and DOS operating system manual(s).
- Other instruction manuals applicable to your hardware configuration

## 1.2 Related Hardware and Software

M/N 57C430A contains one 256K AutoMax Processor module.  
M/N 57C431 contains one 512K AutoMax Processor module.  
M/N 57C435 contains one 512K AutoMax Processor module. The Processor module is used with the following hardware and software, which can be purchased separately:

1. IBM-compatible personal computer running DOS V3.1 or later.
2. ReSource AutoMax Programming Executive software (various model numbers).
3. M/N 61C127 RS-232C ReSource Interface Cable. This cable is used to connect the personal computer to the Processor module. If you wish, you may also build your own cable using the pin description found in Appendix C.
4. M/N 57C413B, 57C423 Common Memory module. This module is used when there is more than one Processor in the rack.
5. RS-232C cable used for communicating with other devices through the Processor ports in the rack not reserved for connection to the personal computer. If you intend to use these ports, you will need to build your own cable using the pin description found in Appendix C.
6. M/N 57C331, 57C332 or 57C334 AutoMax Panel-Mount Rack.
7. M/N 57C491, M/N 57C493, or M/N 57C494 AutoMax Power Supply Module.



8. M/N 57C385 AutoMax Replacement Battery. Note that the Processor module comes equipped with one (1) battery.
9. M/N 57C404A Network Communications module. This module is used to connect racks together as a network and supports communication with all racks on the network that contain 57C404A modules through a single Processor module. M/N 57C404 can be used to connect racks on a network; however, you cannot communicate over the network to the racks that contain M/N 57C404 Network modules. You must instead connect directly to the Processors in these racks.

## 1.3 Compatibility with Earlier Versions

AutoMax Processor module M/N 57C430A, M/N 57C431, and M/N 57C435 are not compatible with Version 1.0 of the AutoMax Programming Executive software (M/N 57C304-57C307).

Processor module M/N 57C430A and M/N 57C431 require Version 2.0 or later of the AutoMax Programming Executive software. M/N 57C435 requires Version 3.1 or later of the AutoMax Programming Executive software. M/N 57C430 cannot co-exist in the same rack with M/N 57C430A, 57C431, or 57C435.

<b>AutoMax Programming Executive Software</b>	<b>Compatible Processor Module</b>
Version 1.0	
M/N 57C304, 57C305	M/N 57C430
M/N 57C306, 57C307 (updates)	M/N 57C430
Version 2.0	
M/N 57C390, 57C391	M/N 57C430A
M/N 57C392, 57C393 (updates)	M/N 57C430A
Version 2.1D	
M/N 57C391	M/N 57C430A
	M/N 57C431
	M/N 57C435
M/N 57C393 (update)	M/N 57C430A
	M/N 57C431
	M/N 57C435
Version 3.0	
M/N 57C395	M/N 57C430A
M/N 57C397 (update)	M/N 57C430A
Version 3.1	
M/N 57C395	M/N 57C430A
	M/N 57C431
	M/N 57C435
M/N 57C397 (update)	M/N 57C430A
	M/N 57C431
	M/N 57C435
Version 3.3 and later*	
M/N 57C395	M/N 57C430A
	M/N 57C431
	M/N 57C435
M/N 57C397 (update)	M/N 57C430A
	M/N 57C431

\*Note that if you are using the AutoMax Programming Executive for drive control applications, the Universal Drive Controller module (B/M 57552) is supported only in Version 3.3 and later of the Programming Executive software.



## 2.0 MECHANICAL/ELECTRICAL DESCRIPTION

The following is a description of the faceplate LEDs, field termination connectors, and electrical characteristics of the field connections.

### 2.1 Mechanical Description

The Processor module is a printed circuit board assembly that plugs into the backplane of the DCS 5000/AutoMax rack. It consists of the printed circuit board, a faceplate, and a protective enclosure. The faceplate contains tabs at the top and bottom to simplify removing the module from the rack. On the back of the module are two edge connectors that connect to the system backplane. Module dimensions are listed in Appendix A.

The faceplate of the Processor module contains two independently-isolated 25-pin "D" shell connectors for RS-232C serial I/O links. The upper port (labeled "PROGRAMMER/PORT B") of the leftmost Processor in the rack is reserved for connection to the personal computer only. The personal computer can communicate with all Processors in the rack through this connection.

All remaining Processor module ports (both those labeled "PROGRAMMER/PORT B" and "PORT A") are available for use by application tasks running on the respective Processors. Refer to figure 2.1 for the Processor module faceplate and Appendix C for a pin description.

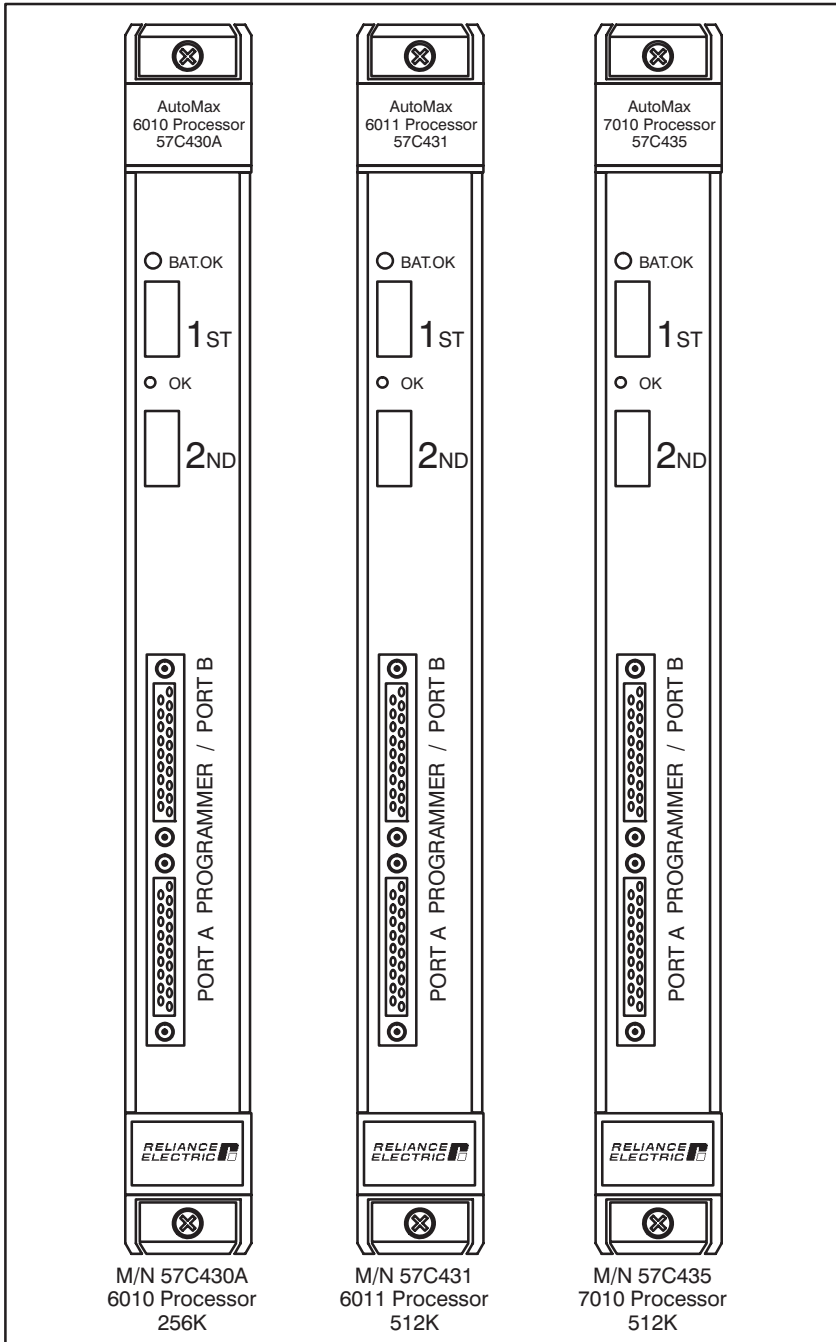

Figure 2.1 - Processor Module Faceplate

The faceplate contains two green status lights and two seven-segment LEDs used for diagnostic purposes. The upper status light, labeled "BAT. OK", indicates whether the on-board battery is providing sufficient voltage to retain the contents of RAM (ON) or should be replaced (OFF). See 3.4 for directions on replacing the battery and Appendix A for battery specifications. The lower status light, labeled "OK", indicates whether the board is operational (ON) or should be replaced (OFF).

Five pre-assigned variables are available for use in all application tasks to test the status of the on-board battery. These common boolean variables will have the value 1 if the battery is functional and 0 if the battery is not functional. The variables are named according to the Processor whose battery is being tested. BATTERYSTATUS0@ is used for the Processor in slot 0. BATTERYSTATUS1@ is used for the Processor in slot 1, etc. up to slot 4.

See 3.5.1 and 3.5.2 for more information about the two seven-segment LEDs on the Processor.

## 2.2 Electrical Description

The Processor module contains a local watchdog timer which must be reset within a specified interval or the Processor will shut down and all I/O modules will be reset (initialized to 0, FALSE, or OFF). Byte parity is supported for all backplane address and data lines.

The super-capacitor on the Processor module can be charged to more than 90% of its rated capacity in approximately 15 minutes and is typically capable of retaining the contents of RAM memory for approximately 10 hours should the "BAT. OK" light go out and power is removed from the Processor.

The Processor serial ports support full modem control. RS-232C signals have 450V isolation to logic common. Refer to figure 2.1 for a typical circuit diagram.

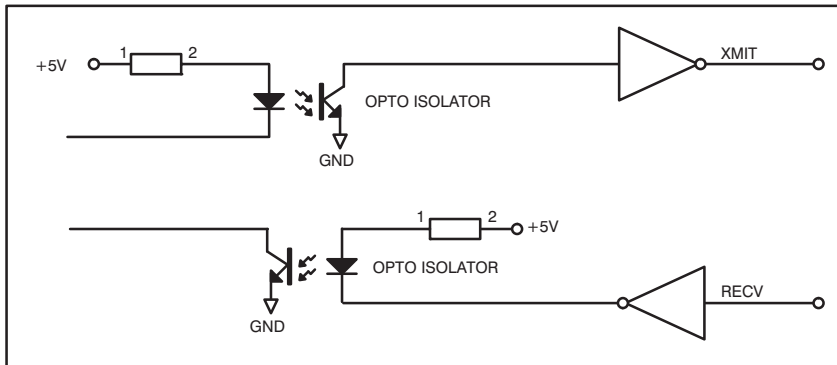

Figure 2.2 - Typical RS-232C Circuit

Refer to 4.2 for more information on the characteristics of the Processor ports available to the user through application tasks.



## 3.0 INSTALLATION

This section describes how to install and replace the Processor module and the on-board battery. M/N 57C430A and M/N 57C431 can be installed in the same rack.

### DANGER

**THE USER IS RESPONSIBLE FOR CONFORMING WITH THE NATIONAL ELECTRICAL CODE AND ALL OTHER APPLICABLE LOCAL CODES. WIRING PRACTICES, GROUNDING, DISCONNECTS, AND OVER-CURRENT PROTECTION ARE OF PARTICULAR IMPORTANCE. FAILURE TO OBSERVE THIS PRECAUTION CAN RESULT IN SERIOUS BODILY INJURY OR LOSS OF LIFE.**

### 3.1 Wiring

To reduce the possibility of electrical noise interfering with the proper operation of the control system, exercise care when installing the wiring from the system to the external devices. For detailed recommendations refer to IEEE 518.

### 3.2 Initial Installation

Use the following procedure to install the module:

- Step 1. Turn off power to the system.
- Step 2. If one or both of the RS-232C ports on the Processor are to be used by application tasks for serial communication with devices other than the personal computer, use shielded RS-232 cables. Cable connectors must be equipped with EMI/RFI-shielded cable clamps attached to the cable shield. The cable shield must be grounded at one end. The cable length must be in accordance with the RS-232 specification. Be sure to label the connector so that it can be easily reconnected later should it ever need to be removed. A pin description can be found in Appendix C.
- Step 3. Take the module out of its shipping container. Take it out of the anti-static bag, being careful not to touch the connectors on the back of the module.
- Step 4. Activate the on-board battery. When viewing the Processor module from the front, you can access the battery through the opening in the right wall portion of the Processor's protective enclosure. Activate the battery by taking it out of its holder and removing the tape that covers it. Replace the battery in its holder. Make certain that the battery is facing in the proper direction, i.e., the end marked "+" on the battery is facing the end marked "+" on the battery holder.

Note that the battery will begin to charge the super-capacitor as soon as the battery is replaced in its holder. For maximum battery life, you should not remove

the tape from the battery unless you intend to turn power on to the module immediately.

If you are in a programming “check-out” mode during which power may be left off for extended periods of time, you may wish to leave the tape on the battery and use the super-capacitor for backup instead. The super-capacitor will typically provide 10 hours of backup. Using the super-capacitor for this purpose will extend the life of the battery.

- Step 5. Insert the module into the desired slot in the rack. In a single Processor configuration, you can insert the Processor in any slot 0–4. If the rack will contain multiple Processors, they can only be placed in slots 1–4. In this configuration, slot 0 is reserved for the Common Memory module. Refer to figure 3.1.

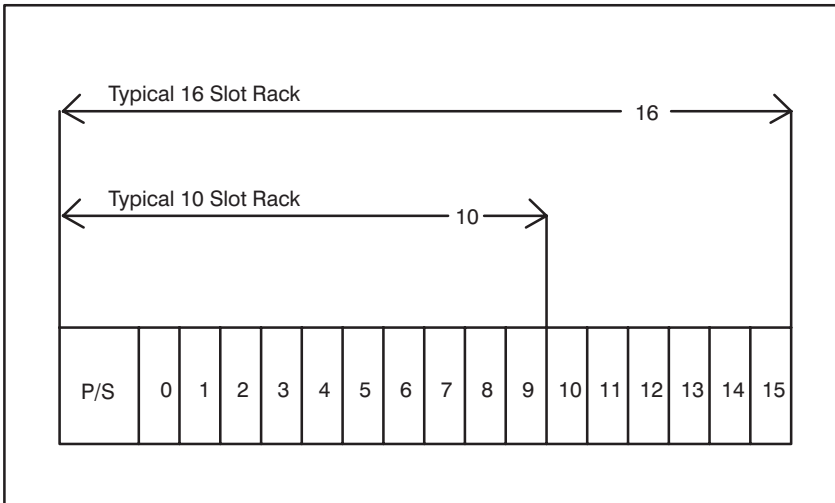

Figure 3.1 - Rack Slot Numbers

- Step 6. Using a screwdriver, attach cable M/N 61C127 (or your own cable, built according to directions in Appendix C), to the port labeled “PROGRAMMER/PORT B” on the leftmost Processor. Attach the cable from step #2 above to ports being used to communicate with other devices.
- Step 7. Turn on power to the system. The module will automatically execute its power-up diagnostics. See 3.5.1 for more information. When diagnostics are complete, the seven-segment LEDs on the faceplate of the leftmost Processor module will display “LO”, reading top to bottom. Code “LO” means that the operating system needs to be loaded onto the Processors in the rack. See 4.1 for instructions on loading the operating system. The LEDs on all other Processor modules in the rack should be blank. The green “OK” light on all Processors should be lit. The “BAT. OK” light on all Processors should also be lit if the tape was removed from the batteries.
- Step 8. Load the operating system using the directions in 4.1.



### 3.3 Module Replacement

When you replace the Processor module in a single-Processor rack, you will need to re-load the operating system and all application tasks unless the new Processor already has the operating system loaded on it and the contents of RAM are valid. In this case, you will need to load the application tasks only.

In a multiple-Processor rack, if your replacement Processor does not already have an operating system and valid RAM, you will have to re-load the operating system and all application tasks to all Processors in the rack. If the new Processor has an operating system, you need only load the application tasks that you want to run on that particular Processor.

Use the following procedure to replace a Processor module:

- Step 1. Turn off power to the system. All power to the rack, as well as all power to the wiring leading to the module, should be off.
- Step 2. Use a screwdriver to loosen the screws holding the RS-232C connectors to the Processor. Detach the connectors from the module.
- Step 3. Loosen the screws that hold the module in the rack. Remove the module from the slot in the rack.
- Step 4. Place the module in the anti-static bag it came in, being careful not to touch the connectors on the back of the module. Place the module and the anti-static bag in the cardboard shipping container.
- Step 5. Take the new module out of the anti-static bag, being careful not to touch the connectors on the back of the module.
- Step 6. Activate the battery by taking it out of its holder and removing the tape that covers it. Replace the battery in its holder. Make certain that the battery is facing in the proper direction, i.e., the end marked "+" on the battery is facing the end marked "+" on the battery holder.
- Step 7. Insert the module into the correct slot in the rack. Use a screwdriver to secure the module into the slot.
- Step 8. Attach the RS-232C cable connector(s) to the mating half on the module. Make certain that the connector is the proper one for this module. Use a screwdriver to secure the connector to the module.
- Step 9. Turn on power to the system. The module will automatically execute its power-up diagnostics. At the completion of its diagnostics, the seven segment LEDs on the faceplate should display "LO" if this is the only Processor module in the rack or the leftmost Processor in a multi-Processor configuration and there is no operating system on the Processor. The LEDs on all other Processor modules should be blank. The green "OK" light should be lit, and the "BAT. OK" should be lit if the tape was removed from the battery.
- Step 10. Load the operating system using the directions in 4.1.

## 3.4 On-Board Battery Replacement

### WARNING

**THE BATTERY USED WITH THIS DEVICE MAY PRESENT A HAZARD IF MISTREATED. DO NOT RECHARGE, DISASSEMBLE, HEAT ABOVE 100°C (212°F), INCINERATE, OR SWALLOW. REPLACE BATTERY WITH RELIANCE ELECTRIC M/N 57C385 ONLY. DISPOSE OF USED BATTERY PROMPTLY. FAILURE TO OBSERVE THIS PRECAUTION COULD RESULT IN BODILY INJURY.**

See section 5.2 for a list of the possible reasons that the “BAT. OK” light on the Processor faceplate can shut off. If you need to replace the battery, the super-capacitor will provide a typical 10 hours of back-up power between the time the “BAT. OK” light goes off and power is removed from the rack, and the time you insert and activate the new battery. If you replace the battery within this time limit, you will not need to re-load the operating system and application tasks. Complete battery specifications can be found in Appendix A.

Use the following procedure to replace the battery on the Processor module.

- Step 1. Turn off power to the system. All power to the rack, as well as all power to the wiring leading to the module, should be off.
- Step 2. Use a screwdriver to loosen the screws holding the connectors to the module. Remove the connectors from the module.
- Step 3. Loosen the screws that hold the module in the rack. Remove the module from the slot in the rack, being careful not to touch the connectors on the back of the module.
- Step 4. Take the old battery out of the holder. Remove the tape from the new battery and insert it in the holder. Make certain that the battery is facing the proper direction.
- Step 5. Re-insert the module into the correct slot in the rack. Use a screwdriver to secure the module into the slot.
- Step 6. Re-attach the connector(s) to the mating half on the module. Make certain that the connector is the proper one for this module. Use a screwdriver to secure the connector to the module.
- Step 7. Turn on power to the rack. The module will automatically execute its power-up diagnostics. The green “OK” light should be lit, and the “BAT. OK” should be lit. If this Processor or any Processor in the rack displays code “LO”, you will need to re-load the operating system. See 4.1 for more information.

## 3.5 Processor Module Diagnostics

This section describes the Processor module power-up and run-time diagnostics.

### 3.5.1 Power-Up Diagnostics

When you first turn on power to the Processor module or cycle power, it will run diagnostics on the Eprom and RAM memory, memory management unit, watchdog timer, parity, interrupts, and SIO.

If more than one Processor is located in the rack, the leftmost Processor will also run diagnostics on the Common Memory module. While running diagnostics, which take approximately 5–15 seconds, the Processor modules in the rack will display the code “dd”. When a module has completed its diagnostics, the LED on the faceplate labeled “OK” will be turned on.

Should a malfunction be detected, all Processors in the rack will be shut down and the status code indicating which diagnostic failed will remain on the LED display of the Processor at fault. See Appendix D for a list of power-up diagnostic error codes.

After diagnostics are complete, the Processor begins periodically resetting its watchdog to indicate that it is functioning correctly. In a multiple Processor configuration, all of the Processors in the rack will begin resetting the system watchdog located on the Common Memory module in addition to resetting their own watchdogs. The Processor module will reset its own watchdog regardless of whether the operating system is loaded or not.

Should any watchdog be allowed to expire at any time after power-up diagnostics are complete, all Processors in the rack will be shut down. If application tasks are currently running in the rack, they will be stopped. The green LED labeled “OK” on the faceplate of the module at fault will be turned off. This Processor will assert a signal on the backplane to reset (set 0, FALSE, or OFF) all local and remote I/O modules.

### 3.5.2 Run-Time Diagnostics

During run-time, i.e., while executing application tasks, the Processor continuously performs real-time checking of byte parity on the RAM. The memory management unit (MMU) checks for errors such as writing to locations that are read-only. Should any malfunction be detected, an error code will be displayed on the LEDs and the Processors in the rack will be either stopped or completely shut down, depending upon the severity of the error. See Appendix E for a list of run-time error codes.

Serious hardware malfunctions, however, can result in application tasks that are currently running being stopped, the “OK” indicator being turned off, and the Processor being shut down. Once a Processor module has shut down, it will not execute any instructions or respond to commands from the personal computer until it is reset by cycling power.



## 4.0 PROGRAMMING

For information about programming, see the AutoMax language instruction manuals and the AutoMax Executive instruction manual referenced in 1.1.

The remainder of this section describes how to load the operating system, or runbase, onto the Processor(s) in the rack and how to access the available Processor ports through application tasks. Note that you cannot load a Version 1.0 runbase on a 57C430A or M/N 57C431 Processor module. You must load the runbase from the Version 2.0 or Version 3.0 Programming Executive software. The M/N 57C435 Processor requires the runbase from the Version 3.1 or later Programming Executive software. You will not be able to load the operating system using an earlier version of the Programming Executive software.

### 4.1 Loading the Operating System

Before you can go on-line to any rack in the system, the operating system, or runbase, for the AutoMax Processor module(s) must be loaded to the local rack from the personal computer on which you have installed the AutoMax Executive software. The operating system, which oversees the operation of the CPU and the execution of application tasks, is provided in three versions: 6010/6011 - Standard, 6010/6011 - Ethernet, and 7010 - Standard. The 6010/6011 - Standard or 6010/6011 - Ethernet operating system can be used with M/N 57C430A or M/N 57C431 Processors. In order to use the Ethernet functions that allow communication over Ethernet using the TCP/IP protocol, an Ethernet Network Interface module (M/N 47C440) must be installed in the rack and the Ethernet operating system must be used. The Ethernet operating system is also required if any of the following functions are used in BASIC tasks: READVAR%, WRITEVAR%, FINDVAR!, and CONVERT%. The 7010 - Standard operating system, which supports all of the Ethernet functions, must be used with the M/N 57C435 Processor.

When you load the operating system to the Processor modules in the rack, you will be prompted for which operating system you want to load for the M/N 57C430A and M/N 57C431 Processors. The 7010 - Standard operating system will be loaded onto all M/N 57C435 Processors. Note that if you have loaded the 6010/6011 - Standard operating system and then you use the Ethernet functions in an application task, the Processor will display error code 4A on its LEDs when you try to put the task into run.

The 6010/6011 - Ethernet operating system will occupy approximately 121K or RAM, leaving 135K available for application tasks on the M/N 57C430A Processor. The 6010/6011 - Standard operating system will occupy approximately 106K or RAM, leaving 150K available for application tasks on the M/N 57C430A Processor. The M/N 57C431 Processor makes 300K available for application tasks, regardless of which operating system is used. The M/N 57C435 Processor also makes 300K available for application tasks.

The operating system(s) will be loaded at the maximum baud rate available for the Processors being used. If you are using 6010/6011 and 7010 Processors in the same rack, make sure the left-most Processor is a 7010 (M/N 57C435) Processor. This will allow the operating systems to be loaded at 19200 baud. If the leftmost

Processor in the rack is a M/N 57C430A or M/N 57C431, the operating system(s) will be loaded at 9600 baud. At 9600 baud, it will require approximately two minutes to load each operating system to Processors in the rack. Although they are similar, the operating systems for the 6010/6011 and 7010 Processor are different. If there are 6010/6011 and 7010 Processors mixed in the same rack, loading the operating systems will take approximately twice as long as it would if there were only one type of Processor in the rack.

Follow the directions below to load the operating system(s) for all Processor modules in the local rack at one time. You can then load the operating system(s) to all racks on all networks in the system.

**Note: If you load an operating system into a Processor(s) that already contains one, the new operating system will write over the existing operating system, and any tasks in the Processor(s) will be deleted.**

1. If you have not already done so, turn on the personal computer and run the AutoMax Executive by typing  
AUTOMAX2  
or  
AUTOMAX3
2. Turn on power to the rack. You will note that the leftmost Processor module in the rack displays the letters "L" and "O" (reading top to bottom). This code prompts you to Load the Operating system. Because Processor modules have on-board battery backup, you will need to re-load the operating system only when enhancements become available, when you change the password for the rack using the PWOS.EXE utility or when a Processor module in the rack is replaced.
3. If you have not already done so, connect the personal computer to the leftmost processor in the rack, following the directions in 4.4.
4. Enter a <CR> at the initial screen. If you are using AutoMax Version 2, select F10 for "Load Operating System". If you are using AutoMax Version 3, select "Load Operating System" from the Commands menu. Note that you will see the message "Local OS invalid - Direct connection only" before you load the operating system for the first time. The AutoMax Executive software will load the operating system onto all Processor modules in the local rack at the normal baud rate. The AutoMax Executive will display on the screen the portion (%) of the operating system that has been loaded.
5. When installation begins, the code "L" "O" will disappear from the two seven-segment LEDs on the leftmost Processor module. The LEDs should be blank. If any error codes appear on the LEDs of the leftmost Processor, the loading was not successful. Repeat step 4 above.
6. You can now load the operating system to other racks in the system connected to the local rack (the rack to which your personal computer is connected) through 57C404A Network

Communication modules. For any network containing 57C404 Network Communication modules, you must connect directly to each rack on the network to load the operating system (see steps 1-5 above).

All Processors in all racks on a network containing only 57C404A modules can be accessed and loaded through the single connection at the local rack. Note that you do not need to establish a network connection through the ON-LINE menu to load an operating system over a network. The loading procedure is always performed through Load Operating System on the Commands menu.

To load the operating system over a network(s) connected to the local rack through 57C404A Network Communication modules, select "Load Operating System" from the Commands menu again. Select "N" to load the operating system over the network(s). Then select "A" to load the standard operating system or "E" to load the Ethernet operating system. At this point, you have three choices:

- enter "A" to load the operating system to all drops on all networks that do not already have an operating system. When the procedure is complete, the system will print the drop numbers that have not been loaded to the screen.
- enter "O" to load the operating system to all drops on all networks, regardless of whether the Processors in those drops already have an operating system. This option will write over all operating systems that exist in all Processors on all networks. It will also require that you re-load any tasks that exist on those Processors. Note that this option requires the password to be entered.
- enter the slot number of the Network module representing the network you want to load over. If you select this option, you will also be able to choose to load the operating system to one drop, all drops on this network where there is no operating system, or to load the operating system to all drops on this network regardless of whether there is an existing operating system. This third option will require that you re-load any tasks that exist on the Processors whose operating systems were over-written. If you choose the third option, the system will print the drop numbers that have not been loaded to the screen. The password is required to over-write any existing operating system.  
Enter your choice and <CR>.

## 4.2 Accessing Processor Ports

All Processor ports in the rack except the port "PROGRAMMER/PORT B" in the leftmost Processor are available to the user. A port can be accessed using the OPEN statement (OPEN PORTA or OPEN PORTB) in BASIC tasks running on the specific Processor on which the port is located. Refer to J-3675 for more information on the OPEN statement.

Refer to figure 4.1 for information about the OPEN statement SETUP parameter for the AutoMax Processor. Defaults are indicated by (D).

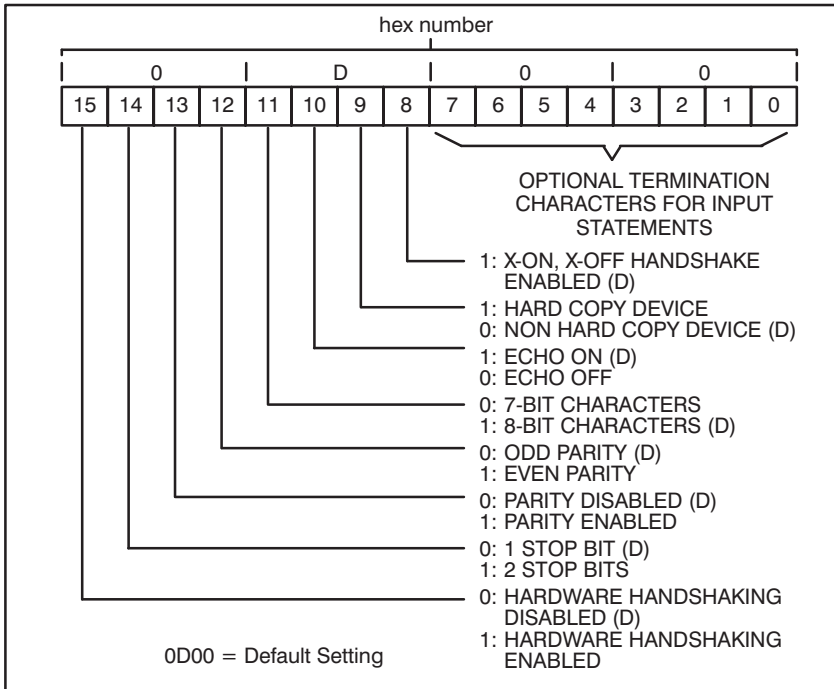

Figure 4.1 - Specifying the SETUP Parameter in an OPEN Statement

### 4.3 Programmable Tick Rate

Control Block, BASIC, and PC tasks can be executed at a fixed scan rate. The scan rate for a Control Block task is set using the SCAN\_LOOP function; the scan rate for a BASIC task is set using the START EVERY statement; the scan rate for a PC task is set in the editor. (In addition, a BASIC task can be delayed by using the DELAY statement.) All of these scan rates can be specified in terms of ticks.

The “programmable tick rate” allows you to change the definition of the tick. By changing the tick, the time base for tasks is changed. This change allows you to run a task at a scan rate other than the default of 5.5 msec. It also allows you to execute application tasks at more easily understood scan times (5.0 msec or 10.0 msec.).

The tick rate is set using the Rack Configurator in the AutoMax Programming Executive Version 3.1 or later. It is not available when using previous versions of the Programming Executive. The tick rate can be set when a Processor module is added or modified. The programmable tick rate can be set in increments of 0.5 msec. between 0.5 msec and 10.0 msec. For compatibility, the default tick rate is 5.5 msec. The tick rate is defined separately for each Processor in a rack.

The tick rate is transferred when the configuration object code is transferred to the Processor. The tick rate is set on the Processor immediately when the configuration is loaded.



A Control Block task containing the CML block must not be present when a tick rate of other than 5.5 msec. is used. If a Control Block task with the CML block is installed and the tick rate is not 5.5 msec., the task installation will fail.

A tick rate below 2.0 msec is not recommended for 6010/6011 Processors due to system overhead. A Control Block task containing with at most 15 average blocks (an average block has a 70  $\mu$ sec execution time) can run with a 2.0 msec. tick rate; a task with 30 blocks can run at 3.0 msec.

## **4.4 Restrictions**

This section describes limitations and restrictions on the use of this module.

### **4.4.1 Number of Processors in a Rack**

A maximum of four Processor modules may be plugged into the rack. M/N 57C430A, M/N 57C431, and M/N 57C435 can be used in the same rack.

### **4.4.2 Rack Slot Restrictions**

A Processor module can occupy any slot from 0-4 in the 6, 10 or 16-slot AutoMax rack. If the rack will contain multiple Processors, slot 0 must contain a Common Memory module and slots 1-4 can contain Processors.

### **4.4.3 Use with the DCS5000 M/N 57C407 Processor Module or the 57C430 Processor Module**

A M/N 57C430A, M/N 57C431, or M/N 57C435 Processor module cannot be used in a rack that also contains a M/N 57C407 Processor module or a 57C430 Processor module.

A rack can contain either 1) DCS5000 Processors only, or 2) M/N 57C430A, 57C431, and 57C435 Processors only. You can, however, connect the racks together over a network.

### **4.4.4 Ethernet Commands**

All tasks using Ethernet commands must be run on the left-most Processor in the rack.



# 5.0 DIAGNOSTICS AND TROUBLESHOOTING

This section explains how to troubleshoot the Processor module and field connections. If the problem cannot be corrected by following the instructions below, the module is not user-serviceable.

## WARNING

**WHEN WRITING TO OUTPUTS, BE CAREFUL TO INSURE THAT NO UNEXPECTED MACHINE MOTION WILL RESULT. FAILURE TO OBSERVE THIS PRECAUTION COULD RESULT IN BODILY INJURY OR DAMAGE TO EQUIPMENT.**

### 5.1 The “OK” LED Is Off

Problem: The “OK” LED on the Processor module faceplate is off. The possible causes of this problem are the following: the Processor has failed its powerup diagnostics, the watchdog timer has been allowed to expire, or the power supply is malfunctioning. If the power supply is functioning correctly, i.e., providing sufficient power to the rack, the Processor module must be replaced. Use the following procedure to isolate a problem with the power supply:

## DANGER

**THE CONNECTOR ON THE FACEPLATE OF THE POWER SUPPLY IS AT LINE VOLTAGE WHEN AC POWER IS APPLIED. DISCONNECT ALL POWER FROM THE POWER SUPPLY BEFORE HANDLING THE WIRING. FAILURE TO OBSERVE THIS PRECAUTION COULD RESULT IN SEVERE BODILY INJURY OR LOSS OF LIFE.**

- Step 1. Verify that the power supply is receiving 115V AC power. If the power is on, the “POWER ON” LED on the power supply faceplate should be lit, indicating the presence of 115V AC power. If the LED is not lit, check the wiring to the faceplate terminals marked “120VAC L1” and “L2”.
- Step 2. Verify that there has been no short circuit.
  - A. If you are using Power Supply M/N 57C491:
    - If the power is on, the “P/S READY” LED on the power supply faceplate should be on. If the LED is off, use the following procedure to isolate the problem.
    - a) Turn off power to the Rack and all connections. Wait until the LEDs on the faceplate of the Power Supply have gone out. Use a screwdriver to loosen the screws holding the Power Supply module in the Rack. Slide the module out about one inch to ensure that the backplane connections have been broken. Do not take the module out of the Rack.

- b) Turn on power to the Rack. If the P/S FAULT LED turns on, the problem lies in the Rack backplane. Go on to step 2c.  
If the P/S READY LED does not light, the Power Supply module is malfunctioning and needs to be replaced.
- c) Turn off power again. Wait until all LEDs on the faceplate of the Power Supply module have gone out. Use a screwdriver to disconnect the terminal strip from the Power Supply module. Do not remove the wires from the terminal strip.
- d) Remove the module from the Rack and verify that card edge connectors are clean and that the connectors on the backplane are in good condition.
- e) Re-insert the Power Supply module. Use a screwdriver to re-connect the terminal strip to the Power Supply module. Turn on power to the Rack. If the problem is not corrected, replace the Rack.

B. If you are using Power Supply M/N 57C493:

The FAULT LED on the Power Supply module should always be off when input power is on, the Power Supply output voltage is within proper limits, and the watchdog alarm coming from the backplane is not active. If the Power Supply FAULT LED is on, use the following procedure to isolate the problem.

- a) Turn off power to the rack and all connections.
- b) Replace the Processor module whose OK LED was off.
- c) Turn on power to the rack. If the Power Supply FAULT LED turns on, the problem is with the Power Supply.

Step 3. Verify that the power supply output is sufficient to power all of the modules in the rack.

Check the total power requirements for the modules in the rack against the power supply output.

## 5.2 The “BAT. OK” LED Is Off

Problem: The “BAT. OK” LED on the Processor module faceplate is off. The possible causes of this problem are the following:

- the tape covering the battery has not been removed
- the battery is not facing in the proper direction
- the battery is missing
- the battery is malfunctioning
- the power supply is malfunctioning

To correct the problem, first turn off power to the rack. Refer to steps 1-3 in section 3.4 for instructions on taking the Processor module out of the rack to inspect the battery. If the tape is still covering the battery, remove it. If the battery is missing or not facing in the proper direction, insert the battery with the “+” end facing the “+” marking

on the battery holder. If none of the above actions correct the problem, replace the battery.

### 5.3 BUS ERROR

Problem: Codes “31” or “50” through “58” appear on the Processor module’s LEDs. These codes signify that a bus error occurred when the system attempted to access an I/O module. The possible causes of this error are the following: a missing module, a module in the wrong slot, or a malfunctioning module. It is also possible that the user has attempted to write to the wrong registers on a module through an application task. Use the following procedure to isolate a bus error:

Step 1. Determine where the bus error occurred.

Connect the personal computer to the rack and run the ReSource AutoMax Programming Executive. Display the error log for the Processor that indicates the error. The error log should indicate the address that caused the bus error or a line number in a BASIC or Control Block application task. The address will be displayed in hexadecimal notation. To decode the address, follow the directions below.

- a. To determine the slot number where the bus error occurred, convert the hex address into a bit pattern and decode in decimal notation as follows:

Most Significant 16 Bits

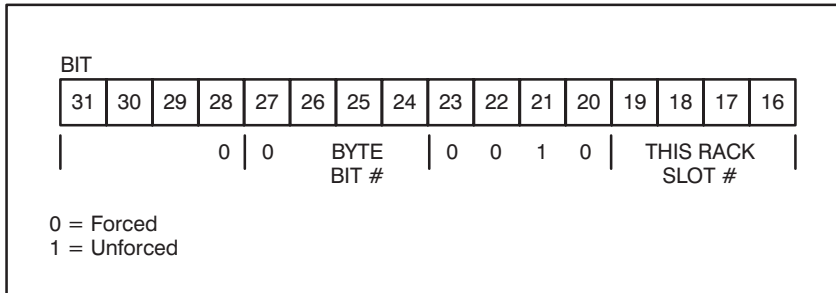

- b. To determine the register in the slot where the bus error occurred, take the slot number you decode in "THIS RACK SLOT #" and decode the least significant 16 bits according to the type of module found in the slot:

Any Local I/O Module\*  
Least Significant 16 Bits

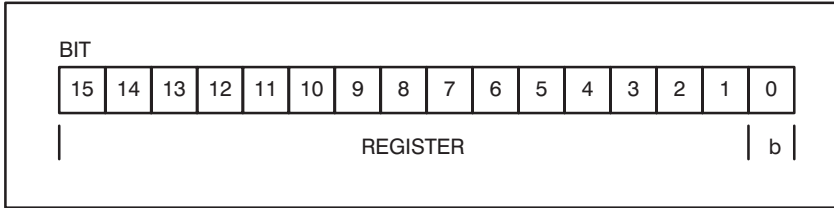

A Remote I/O Module (M/N 57C416)  
Least Significant 16 Bits

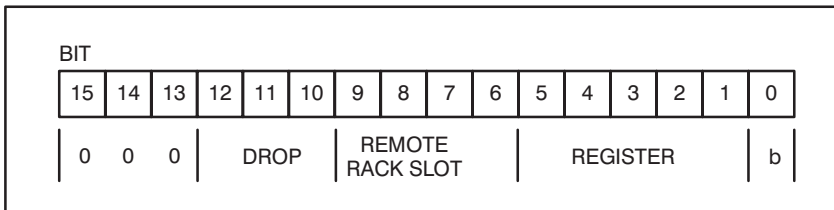

A Network Communications Module (M/N 57C404)  
Least Significant 16 Bits

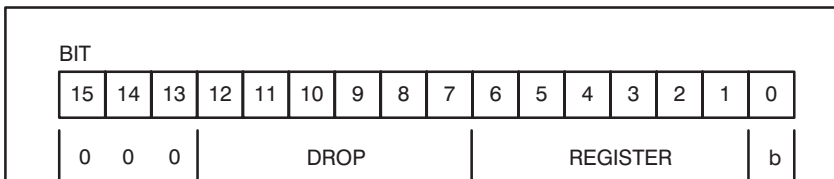

The bit number being accessed may be determined from word  
 $\text{bit \#} = \text{BYTE BIT \#} + (8 * b)$   
 If BYTE BIT # and  $8 * b = 0$ , address may have been accessed  
 as a word (integer) or bit 0 of byte 0.

- \* The hexadecimal number represents the Multibus address of the error. Therefore, the standard Reliance register number for any type of module can be decoded from this figure and the figure in part a. For more specific information, e.g., drop number, use the applicable figures that follow.

A Modbus Interface Module (M/N 57C414)  
Least Significant 16 Bits

BIT

15	14	13	12	11	10	9	8	7	6	5	4	3	2	1	0
----	----	----	----	----	----	---	---	---	---	---	---	---	---	---	---

| R | b |

where R is a local register address, which may be used with the I/O monitor.  
Determine the Modbus register number from the following table:

R (Decimal)	Modbus Register (Decimal)
64 – 319	$[(R - 64) * 16] + \text{BYTE BIT \#} + 8 * b + 1$
320 – 575	$[(R - 320) * 16] + \text{BYTE BIT \#} + 8 * b + 10001$
576 – 1599	$(R - 576) + 30001$
1600 – 2623	$(R - 1600) + 40001$

An Allen-Bradley Interface Module (M/N 57C418)  
Least Significant 16 Bits

BIT

15	14	13	12	11	10	9	8	7	6	5	4	3	2	1	0
----	----	----	----	----	----	---	---	---	---	---	---	---	---	---	---

| R | b |

where R is a local register address, which may be used with the I/O monitor.  
Determine the A-B register number from the following table:

R (Decimal)	A-B File	A-B Register (Decimal)
64 – 319	B0	R – 64
320 – 575	B1	R – 320
576 – 1599	N0	R – 576
1600 – 2623	N1	R – 1600

An AutoMate Interface Module (M/N 57C417)  
Least Significant 16 Bits

BIT

15	14	13	12	11	10	9	8	7	6	5	4	3	2	1	0
----	----	----	----	----	----	---	---	---	---	---	---	---	---	---	---

| R | b |

where R is a local register address, which may be used with the I/O monitor.  
Determine the AutoMate register number from the following table:

R (Decimal)	AutoMate Register (Octal)
64 – 319	0000.00 – 0377.17
320 – 575	0400.00 – 0777.17
576 – 1599	2000 – 3777
1600 – 2623	4000 – 5777

- c. When you have determined the slot and register address at which the bus error occurred, go on to the steps below. If “THIS RACK SLOT #” referred to a Remote I/O or Network module, make certain you are working with the card in the remote or network drop when you go on to the remaining steps in this section.
- Step 2. Verify that there is a module in the slot and that the I/O definitions in the configuration are correct for the module. Refer to figure 3.2. Verify that the register numbers defined in the configuration are valid for the module.  
  
For remote I/O installations, also verify that the master slot and remote drop number are defined correctly.
  - Step 3. Verify that the module can be accessed.  
  
Use the I/O Monitor function in the ReSource AutoMax Programming Executive to display the registers on the module. If the personal computer is able to monitor the registers, the problem lies in the application software (refer to step 4). If you cannot monitor the registers, the problem is in the hardware (refer to step 5).
  - Step 4. Verify that the user application software is correct.  
  
If a BASIC task caused the bus error, the error log will contain the statement number in the task where the error occurred. If a Control Block or Ladder Logic task caused the error, you will need to search the task for any instances where you wrote to an input.
  - Step 5. Verify that the hardware is working correctly.  
  
Verify the hardware functionality by systematically swapping out the module in question, the Processor module(s) or slave Remote I/O module, and the backplane. After each swap, if the problem is not corrected, replace the original item before swapping out the next item.

## 5.4 Common Memory Module Diagnostic Failure

**Problem:** The green LED on a Common Memory module located in slot 0 is off, and a Processor module in the rack displays codes 4.0. through 4.6. These error codes mean that the Common Memory module has failed one of its power-up diagnostics.

Systematically swap out the Common Memory module and the Processor module(s). After each swap, if the problem is not corrected, replace the original item before going on to the next item. If the problem persists, take all of the modules except the Common Memory module and one Processor module out of the rack. If the problem is now corrected, another module in the rack is causing the problem. Replace the remaining modules one at a time until the problem reappears. If none of these tests reveals the problem, try replacing the backplane.



## 5.5 Incorrect Data

**Problem:** The data used by application tasks is either always off, always on, or different than expected. The possible causes of this are the following: a module in the wrong slot, a programming error, or a malfunctioning module.

- Step 1. Verify that all inputs to the rack are wired to the correct devices.  
  
Confirm that all connections at the terminal strip are tight. Connect a voltmeter to the proper points on the terminal strip and toggle each device. Verify that the device is generating the correct voltage or current, depending upon the module you are testing. If the voltage or current is incorrect, there is a problem with the external device, its power supply, or the wiring to the terminal strip.  
  
Check the cable for continuity between the faceplate connector and the terminal strip.
- Step 2. Verify that the input circuit on each input module is working correctly.  
  
Toggle the input devices to verify that the LED associated with each is also toggling. If it is not toggling, either the LED or the input module itself is malfunctioning.
- Step 3. Verify that each module can be accessed.  
  
Connect the personal computer to the rack and run the ReSource AutoMax Programming Executive.  
  
Stop all programs that may be running.  
  
Use the I/O Monitor function to display the individual I/O points or registers on the module, whichever is appropriate. If the points can be monitored, the problem lies in the application software (refer to steps 4 and 5). If the points cannot be monitored, the problem lies in the software (go on to step 6).
- Step 4. For all modules in the rack, verify that the configuration references the correct slot and register locations. For remote I/O installations, also verify that the master slot and drop number are referenced correctly.
- Step 5. Verify that the application programs running in the rack are correct.  
  
Check to see that the application programs that reference the symbolic names associated with the hardware in the rack have declared those names COMMON.
- Step 6. Verify that the hardware is working correctly.  
  
To test local I/O, systematically swap out the module in question and the Processor module(s). If the problem persists, take all of the modules except the module in question and one Processor out of the rack. If the problem is now corrected, one of the other modules in the rack is causing the problem. Reconnect the other modules one at a time until the problem reappears. If none of these tests reveals the problem, replace the backplane.  
  
To test the remote I/O system, first verify that the remote I/O system is communicating with the drop that contains the module being tested. Next, by systematically

swapping out modules, determine whether the module being tested is the only module that is not working correctly. If more than one module is not working correctly, the problem most likely lies in the remote I/O system. Refer to the instruction manual for the M/N 57C416 Remote I/O Communications module for more information. If the problem does not lie in the remote I/O system, it probably involves the remote rack.

To test the remote rack, systematically swap out the module being tested and the slave Remote I/O module. If the problem persists, take all of the modules except the slave Remote I/O module and the module being tested out of the rack. If the problem is now corrected, one of the other modules in the rack is malfunctioning. Re-connect the other modules one at a time until the problem reappears. If the problem appears to be neither in the remote I/O system nor in the remote rack replace the backplane.

# Appendix A

## Technical Specifications

### M/N 57C430A

#### Ambient Conditions

- Storage temperature:  $-40^{\circ}\text{C}$  -  $85^{\circ}\text{C}$
- Operating temperature:  $0^{\circ}\text{C}$  -  $60^{\circ}\text{C}$
- Humidity: 5-90% non-condensing

#### Maximum Module Power Dissipation

- 15 Watts average

#### Dimensions

- Height: 11.75 inches
- Width: 1.25 inches
- Depth: 7.37 inches

#### System Power Requirements

- 5 Volts: 3000 mA average
- +12 Volts: 100 mA average
- -12 Volts: 100 mA average

#### Battery Specifications

- Type: Lithium
- Size: AA
- Voltage: 3.6 Volts
- Amp. Hrs.: 2.0

#### Memory Retention

- Minimum hold-up with battery: 42 days
- Typical hold-up with battery: 333 days
- Minimum hold-up without battery: 10 minutes
- Typical hold-up without battery: 10 hours
- Maximum charge-up time: 15 minutes

#### Serial Port Specifications

- Type: RS-232C
- Electrical Isolation: 450 Volts
- Voltage:  $\pm 12$  Volts
- Maximum current per channel:  $\pm 30$  mA

# Appendix A (Continued)

## Technical Specifications M/N 57C431

### Ambient Conditions

- Storage temperature:  $-40^{\circ}\text{C}$  -  $85^{\circ}\text{C}$
- Operating temperature:  $0^{\circ}\text{C}$  -  $60^{\circ}\text{C}$
- Humidity: 5-90% non-condensing

### Maximum Module Power Dissipation

- 15 Watts average

### Dimensions

- Height: 11.75 inches
- Width: 1.25 inches
- Depth: 7.37 inches

### System Power Requirements

- 5 Volts: 3000 mA average
- +12 Volts: 100 mA average
- -12 Volts: 100 mA average

### Battery Specifications

- Type: Lithium
- Size: AA
- Voltage: 3.6 Volts
- Amp. Hrs.: 2.0

### Memory Retention

- Minimum hold-up with battery: 42 days
- Typical hold-up with battery: 333 days
- Minimum hold-up without battery: 10 minutes
- Typical hold-up without battery: 10 hours
- Maximum charge-up time: 15 minutes

### Serial Port Specifications

- Type: RS-232C
- Electrical Isolation: 450 Volts
- Voltage:  $\pm 12$  Volts
- Maximum current per channel:  $\pm 30$  mA

# Appendix A (Continued)

## Technical Specifications M/N 57C435

### Ambient Conditions

- Storage temperature:  $-40^{\circ}\text{C}$  -  $85^{\circ}\text{C}$
- Operating temperature:  $0^{\circ}\text{C}$  -  $60^{\circ}\text{C}$
- Humidity: 5-90% non-condensing

### Maximum Module Power Dissipation

- 15 Watts average

### Dimensions

- Height: 11.75 inches
- Width: 1.25 inches
- Depth: 7.37 inches

### System Power Requirements

- 5 Volts: 3000 mA average
- +12 Volts: 100 mA average
- -12 Volts: 100 mA average

### Battery Specifications

- Type: Lithium
- Size: AA
- Voltage: 3.6 Volts
- Amp. Hrs.: 2.0

### Memory Retention

- Minimum hold-up with battery: 186 days
- Typical hold-up with battery: 8.2 years
- Minimum hold-up without battery: 10 minutes
- Typical hold-up without battery: 10 hours
- Maximum charge-up time: 15 minutes

### Serial Port Specifications

- Type: RS-232C
- Electrical Isolation: 450 Volts
- Voltage:  $\pm 12$  Volts
- Maximum current per channel:  $\pm 30$  mA



# Appendix B

## Module Block Diagram Processor Module (57C430A)

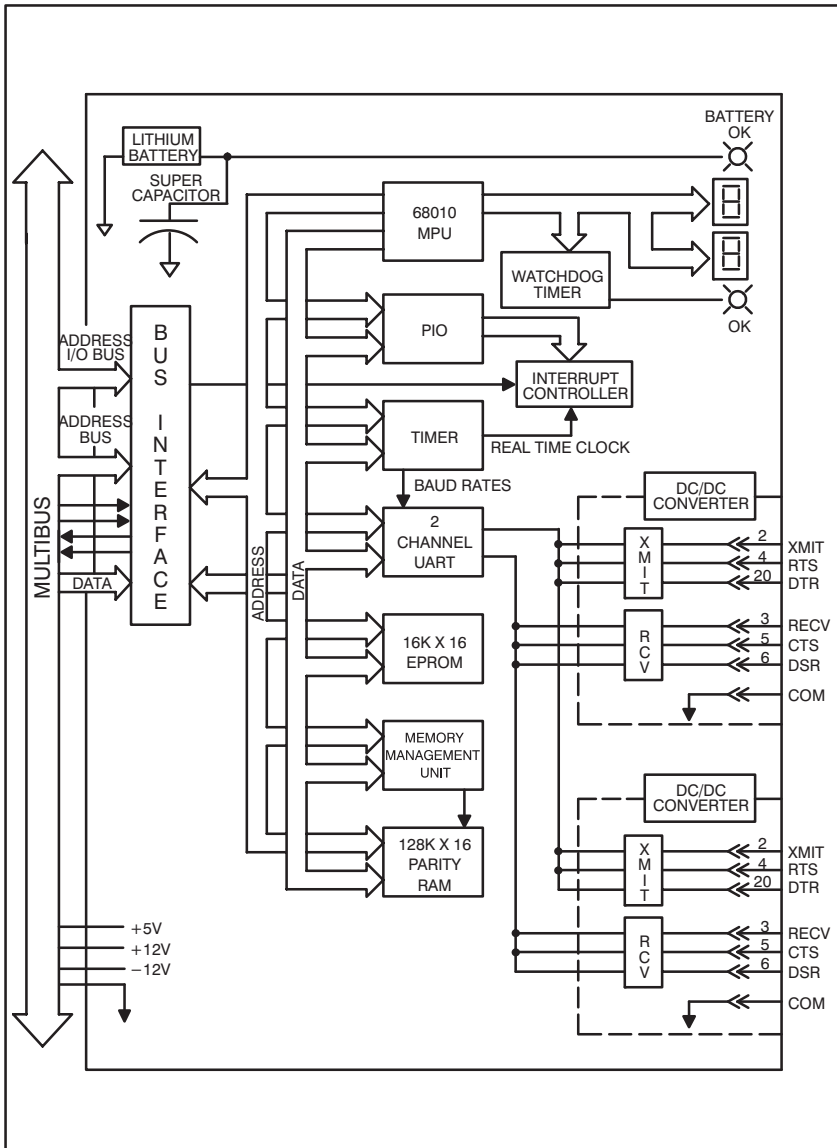

# Appendix B (Continued)

## Module Block Diagram Processor Module (57C431)

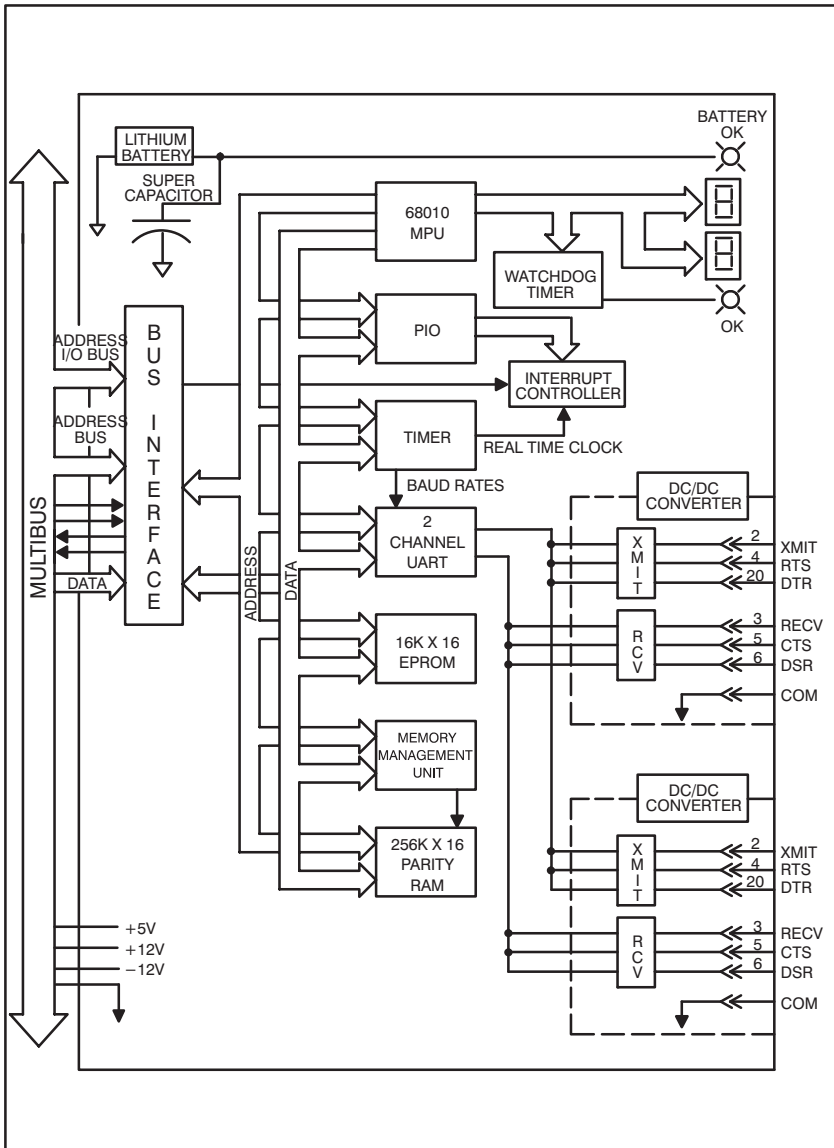



# Appendix B (Continued)

## Module Block Diagram Processor Module (57C435)

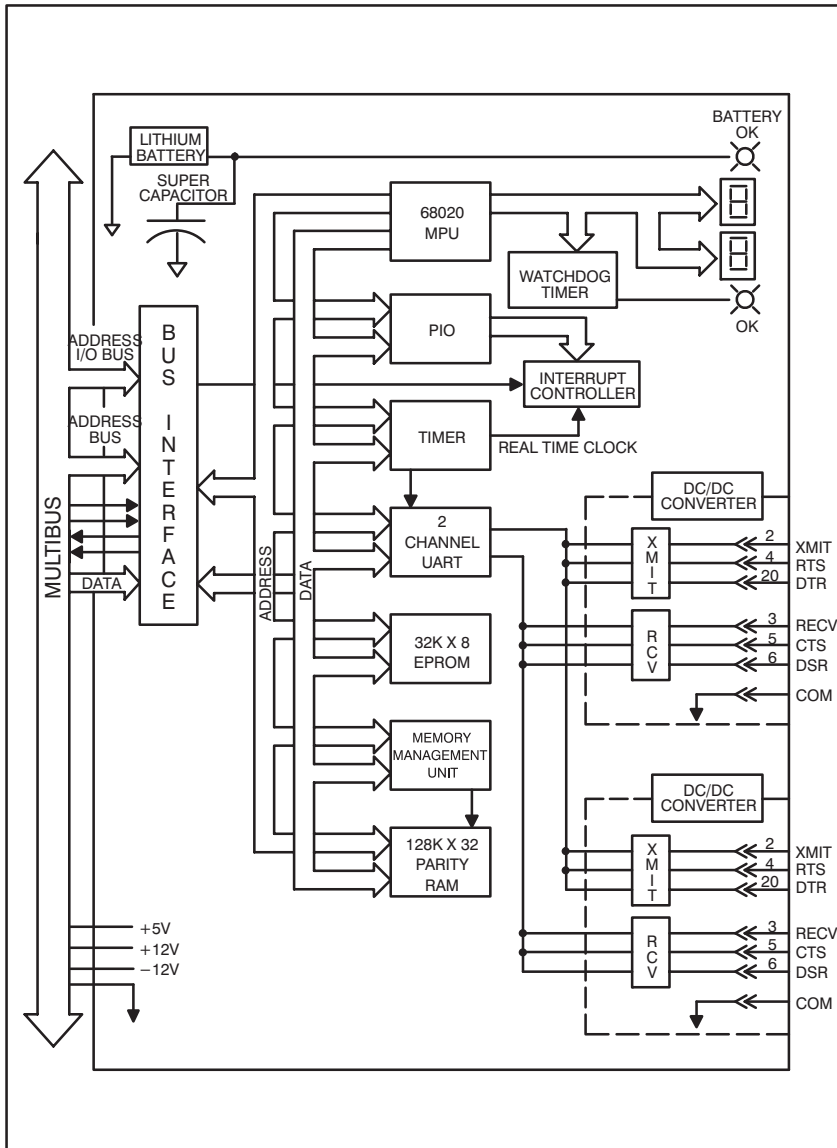



# Appendix C

## Connecting the AutoMax Processor to the Personal Computer

If it is necessary to prepare a cable to connect a personal computer to the AutoMax Processor, follow the steps below. See the PC3000 User Manual (J2-3096) for more information about connecting the PC3000 processor to the personal computer.

### WARNING

**THE FOLLOWING INSTRUCTIONS ARE INTENDED ONLY TO ALLOW FABRICATION OF PROPER CONNECTIONS BETWEEN RELIANCE EQUIPMENT AND USER-PROVIDED PROGRAMMING DEVICES. THE USER MUST READ AND UNDERSTAND ALL APPLICABLE INSTRUCTION MANUALS PRIOR TO OPERATING THE EQUIPMENT. FAILURE TO OBSERVE THIS PRECAUTION COULD RESULT IN BODILY INJURY.**

1. Determine whether your programming terminal contains a 9- or 25-pin male connector.
2. Cut a suitable length (not to exceed 10 feet) of 22-gauge, multi-conductor cable.
3. Follow the connector manufacturer's instructions and make cable connections using figure 1 or 2, whichever is applicable.
4. Check for grounds, shorts, and continuity using an Ohm meter.

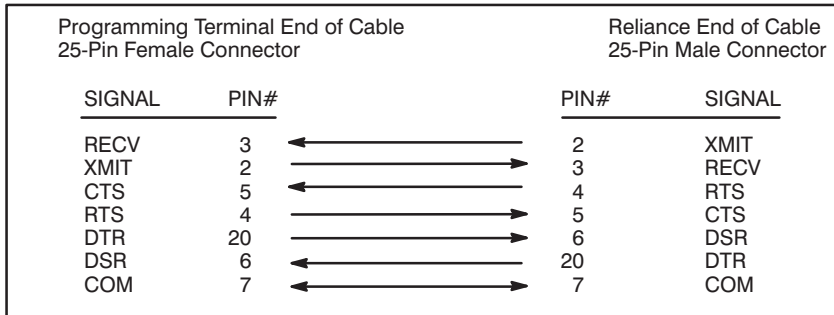

Figure 1

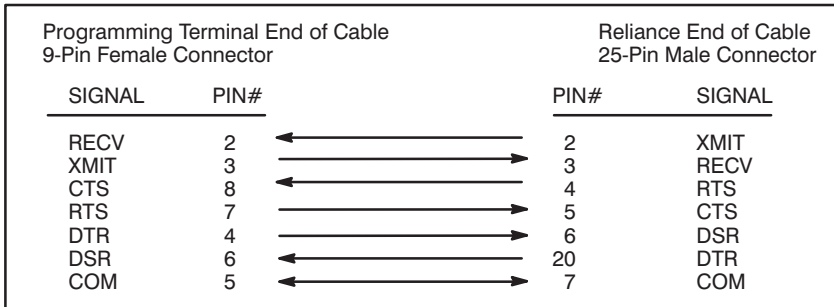

Figure 2

## User Serial Ports

All AutoMax Processor module ports except for the port labeled "PROGRAMMER/PORT B" on the leftmost Processor in the rack are available to the user to connect to an external device which will be controlled by application tasks running on the Processor. Refer to the Enhanced BASIC Language Instruction Manual (J-3675) for more information. Note that with AutoMax Processor modules, you can use the statements OPEN PORTA or OPEN PORTB.

Note: if you do not enable bit 15 (hardware handshaking) in the SETUP parameter of the OPEN statement, only pins 2, 3, and 7 of the port you OPEN will be meaningful.

Pin#	I/O	Function
2	O	This signal contains transmitted data.
3	I	This signal contains received data
4	O	Transmit status. This signal is true whenever the transmitter is sending characters. It is used to "bracket" a character transmission. It can be used to enable/disable any type of external equipment, such as a tri-state transmit modem, which requires an enable signal to output characters. Refer to the OPEN statement in the Enhanced BASIC Language manual (J-3675) for details concerning the operation of the modem enable signal (RTS pin on connector).
5	I	This signal enables the transmitter. It must be true for the transmitter to send a character. This signal is typically used for hardware flow control. It is meaningful only if hardware handshaking has been enabled.
6	I	This signal enables the receiver. It must be true in order for the receiver to accept characters. If the signal becomes false while a message is being received, any characters being received will be deleted and an error will be reported to the application software. This signal is meaningful only if hardware handshaking has been enabled.
7		Signal ground.
10	O	This signal is an isolated +12 Volt which can be used as an enable or equipment ready indicator. The signal is always on whenever power is applied to the Processor.
20	O	This signal indicates receiver status. The signal is true whenever the receiver can accept characters, i.e., when the receive buffer is not full. When the receive buffer fills to within a specified limit (53 characters), the signal is turned off. The signal can be used to disable another transmitter. It is meaningful only when hardware handshaking has been enabled.

See the following page for examples.

# Appendix C

## (Continued)

The following figures describe typical user port pin configurations.

### Modem Transmit Enable with No Flow Control

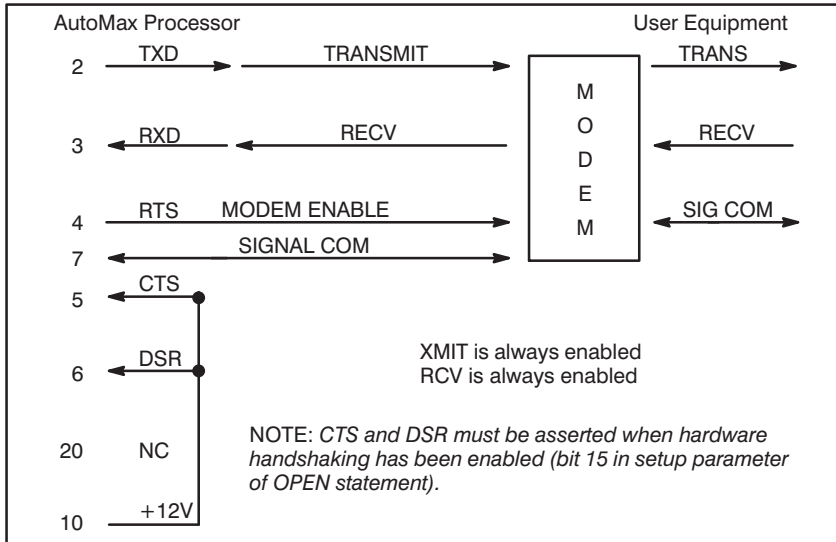

### Cable Break Detect

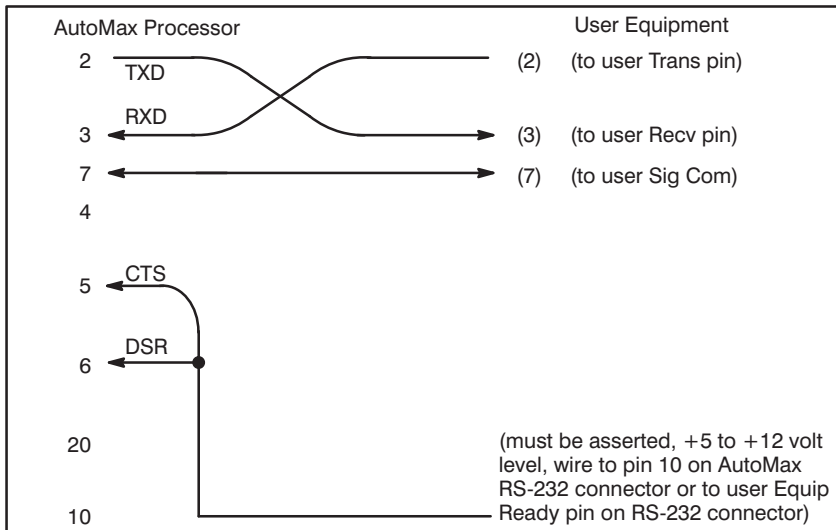

# Appendix C

(Continued)

## One-Directional Flow Control (Hardware Handshaking)

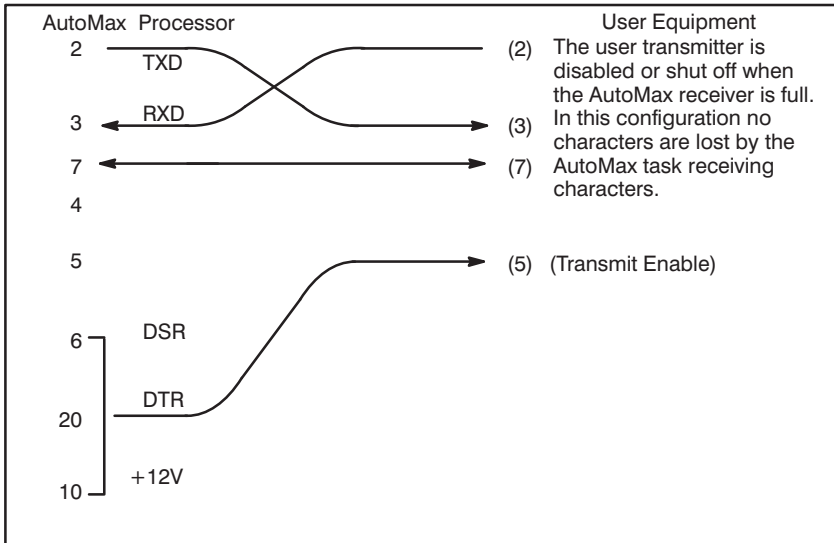

## Bi-Directional Flow Control (Hardware Handshaking)

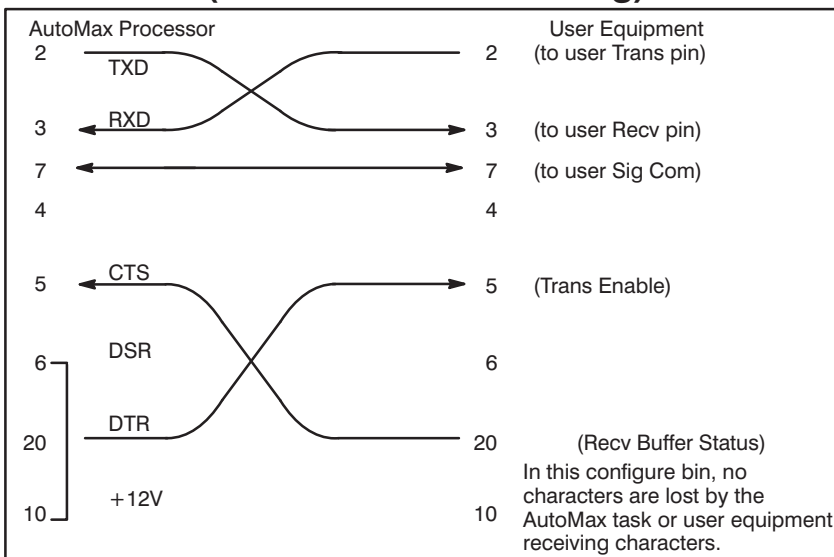

# Appendix D

## Diagnostic LED Error Codes

### Processor Overload

00 CPU overload

Corrective action: move one or more application tasks to other Processor modules in the racks, or make scan times longer.

### Power-Up Diagnostics

The following error codes are displayed while the Processor module performs power-up diagnostics.

0.0. EPROM failed  
0.1.- 0.3. Bad CPU  
0.4. Internal bus error test failure  
0.5. Parity test failure  
0.6. External bus error test failure  
0.7. Processor in the wrong slot  
1.0. - 1.6. RAM failure  
2.0. I/O protection failure  
2.1. PIO failed  
2.2. PC accelerator failed  
2.3. 8253 timer/counter failed  
2.4. SIO failure  
2.5. Communications interrupt failed  
2.6. SIO interrupt failed  
2.7. 8253 counter timer interrupt failed  
2.8. Local watchdog failed  
3.0. Bad backplane  
3.1. Multibus parity test failure  
4.0. - 4.5. Common memory RAM failure  
4.6. Common memory system watchdog failure  
5.0 Processors with incompatible EPROMs in the rack

Corrective action: replace the Processor (M/N 57C430A, 57C431, or 57C435), or replace the Common Memory module (M/N 57C413) if error codes 4.0.- 4.6. remain on.

### Run Time Errors

02 Task or configuration checksum failure

Corrective action: clear the error.

### Runbase Booting

The following status/error codes are displayed while you load the runbase, or operating system, onto the Processor module(s) using the AutoMax programming software. All of the following codes except 6.5. apply to the top port of the Processor module, labeled "Programmer/Port B".

5.1 Incompatible runbase downloaded  
6.0. Unexpected interrupt on upper port of processor  
6.1. Parity error  
6.2. Receiver overrun  
6.3. Framing error

- 6.4. Serial port fatal error
- 6.5. Illegal interrupt on lower port of processor
- 6.6. Transmit interrupt error
- 6.7. Runbase integrity lost
- 6.8. Bad runbase checksum
- 6.9. Transmit buffer error
- 7.0. Multi-processor runbase download in progress
- 7.1. Disconnect time-out during download
- 7.2. Spurious interrupt received

Corrective action: 6.3. may be caused by attempting AutoMax ON-LINE PROGRAMMING functions before the runbase is loaded onto the Processor module(s) in the rack. In this case, exit the ON-LINE PROGRAMMING menu and download the runbase. 7.0 is a status message only. For all other error codes, cycle power and try to load the runbase again.

## **Loading the Runbase over the Network**

- 8.0. Bad message length specified for network message
- 8.1. Bad destination drop
- 8.2. Transmitting drop inactive
- 8.3. Destination port unallocated
- 8.4. Destination port busy
- 8.5. Did not receive expected response
- 8.6. Spurious network interrupt received
- 8.7. Network message is being transmitted

Corrective action: 8.0. and 8.1. are caused by a failed Processor in the leftmost slot. For 8.2., check the coax cable; then try replacing the network module. For 8.3. - 8.5., check the destination Network module, then the leftmost Processor in the destination rack. For 8.6. and 8.7., cycle power and try to load the runbase again.

## **Miscellaneous Process Errors**

- 8.8. Processor failure

Corrective action: replace Processor module.



# Appendix E

## Run Time LED Error Codes

### WARNING

ONLY QUALIFIED PERSONNEL FAMILIAR WITH THE CONSTRUCTION AND OPERATION OF THE CONTROLLED EQUIPMENT SHOULD INSTALL, ADJUST, OPERATE, OR SERVICE THIS EQUIPMENT. READ AND UNDERSTAND THIS MANUAL AND OTHER MANUALS APPLICABLE TO YOUR INSTALLATION. FAILURE TO OBSERVE THIS PRECAUTION COULD RESULT IN BODILY INJURY.

### WARNING

INSERTING OR REMOVING THIS MODULE OR ITS CONNECTING CABLES MAY RESULT IN UNEXPECTED MACHINE MOTION. POWER TO THE MACHINE SHOULD BE TURNED OFF BEFORE INSERTING OR REMOVING THE MODULE OR ITS CONNECTING CABLES. FAILURE TO OBSERVE THESE PRECAUTIONS COULD RESULT IN BODILY INJURY.

### STOP ALL Error Codes

The following hardware and software error codes cause all tasks running in the rack to stop.

- 10 Event count underflow
  - too many WAITs (max. 32768)
  - not enough SETs (BASIC tasks)
- 11 Event count overflow
  - too many SETs (max. 32767)
  - not enough WAITs (BASIC tasks)
- 12 Hardware event time-out
  - interrupt time exceeded programmed time-out limit in a Control Block task
- 13 Runbase boot error
  - a check on the runbase failed
- 14 Processor overlap limit exceeded
  - ran out of processing capacity (time)
- 15 External watchdog time-out detected
  - another processor in the same rack stopped
- 17 Address error detected
  - caused by a read/write to an invalid address
- 18 Spurious interrupt or hardware failure
- 19 Power failure detected
- 1A Watchdog on this Processor failed
- 1b Hardware event count limit exceeded
  - too many interrupts set without being acknowledged
  - program too long
  - collective scans too fast
- 1C Illegal instruction detected
  - runbase software fault
  - bad Processor module
  - bad EPROMs

1d	Privilege violation detected
	- runbase software fault
	- bad Processor module
1E	Un-implemented instruction detected
	- runbase software fault
	- bad Processor module
1F	Illegal interrupt detected
	- runbase software fault
	- bad Processor module
30	Problem in application software
31	Bus error
	- attempt to access invalid address
32	Define channel error
	- problem in application software
33	Define scan error
	- hardware fault
34	Memory integrity lost
	- hardware fault
35	DC drive CML block initialization error
36	Communication between drive processor and I/O controller lost
	- hardware fault
37	DC drive I/O controller run-time board error
	- hardware fault
38	UDC module generated a STOP ALL
39	UDC module interrupt allocation failed
3A	Processor OS incompatible with UDC OS

Corrective action: correct the problem in application software. Try to reset by cycling power and re-loading configuration and application tasks. Replace the Processor module. For error code 31, see J-3650; for error code 37, see J-3669. For error code 17: If you define bits in a register that is also defined as a register, neither the bits nor the register can be forced. For error code 38, examine the error logs for all UDC tasks in the rack. Also, error code 38 can be caused by enabling CCLK on more than one module in the rack. Verify that CCLK is enabled on only one module. For error code 39, cycle power to the rack and re-load the configuration and application tasks.

## BASIC STOP ALL Error Codes

The following error codes are caused by problems in BASIC tasks and cause all tasks to stop.

40	Too many RETURNS from GOSUBs (or RETURN without GOSUB)
41	Illegal jump into a FOR loop
42	NEXT statement does not match current FOR
43	Invalid START EVERY statement
44	Invalid EVENT statement
45	STOP statement executed in application software (causes a STOP ALL/CLEAR)
46	SET or WAIT attempted with no event definition
47	Task stack overflow
48	GOSUBs not balanced at END statement
49	Insufficient space for channel buffer
4A	Attempted to execute undefined opcode
4B	Attempted to execute non-executable opcode
4C	Attempted to execute illegal opcode
4D	RESTORE to non-DATA statement line number
4E	Attempted to take square root of a negative number
4F	Attempted to RESUME without being in an ON ERROR handler

Corrective action: correct the problem in application software. Error code 47 can be caused by performing a PUT on a closed port. Error code 4A can be caused by attempting to use Ethernet functions with the standard operating system loaded. To use Ethernet functions, you must load the Ethernet operating system.

## Multibus and Processor Bus STOP ALL Error Codes

50	Onboard parity error
51-54	Onboard bus error or access violation
55	Multibus parity error during read access
56-58	Multibus access violation or bus error
60	Network interrupt allocation failed
61	Network receiving queue overflow
62	Network transmit queue underflow

Corrective action: reset by cycling power and re-loading configuration and application tasks. If the small green LED labeled "OK" on the Processor module faceplate is off, replace the Processor module. Correct any incorrect accesses in application software. Systematically swap out hardware modules. For error codes 55-58, if none of the above correct the problem, try replacing the backplane.

## Drive-Related Error Codes

The following error codes indicate a power circuit or external drive system fault. After correcting the problem, reset the Processor module to clear the error code.

80	Instantaneous overcurrent fault - armature current exceeded IOC_THRESH value in CML task
81	Line sync loss fault
82	Tach loss fault - 40% armature voltage with less than 5% tach feedback
83	Overspeed/overvoltage fault - CML task OSV_FDBK exceeded OSV_THRESH number
84	Hardware overspeed fault - drive analog module potentiometer setting exceeded by input voltage
85	External IET fault - external fault input triggered
86	Phase rotation fault - incorrect phasing
87	Shorted SCR detected in power module

Corrective action: troubleshoot power circuit and external drive system.

## Configuration Error Codes

The following error codes usually indicate a discrepancy between the actual hardware configuration and the I/O definitions in the configuration for the rack.

E0	TASK specified in configuration uninstalled, at wrong priority, of wrong type, on wrong Processor module; wrong spelling of TASK
E1	Invalid configuration, configuration not successfully downloaded.
E2	I/O referenced in configuration is missing.
E3	I/O referenced in configuration is missing. Invalid configuration, configuration not successfully downloaded.
E4	Error building task, insufficient memory in Processor Module. Invalid configuration, configuration not successfully downloaded.

E5	Error building task, insufficient memory in Processor Module. Invalid configuration, configuration not successfully downloaded.
E6	I/O referenced in configurations is missing. Error building task, insufficient memory in Processor Module.
E7	Invalid configuration, configuration not successfully downloaded. I/O referenced in configuration is missing. Invalid configuration, configuration not successfully downloaded.
E8	Error installing application task, common symbol could not be resolved, insufficient memory in Processor Module.
E9	Error installing application task, common symbol could not be resolved, insufficient memory in Processor Module. Invalid configuration, configuration not successfully downloaded.
EA	Error installing application task, common symbol could not be resolved, insufficient memory in Processor Module. I/O referenced in configuration is missing.
Eb	Error installing application task, common symbol could not be resolved, insufficient memory in Processor Module. I/O referenced in configuration is missing. Invalid configuration, configuration not successfully downloaded.
EC	Error building task; and error installing application task, common symbol could not be resolved, insufficient memory in Processor Module.
Ed	Error building task; and error installing application task, common symbol could not be resolved, insufficient memory in Processor Module. Invalid configuration not successfully downloaded.
EE	Error building task; and error installing application task, common symbol could not be resolved, insufficient memory in Processor Module. I/O referenced in configuration is missing.
EF	Common variable forced by another Processor Module.

Corrective action: verify that the configuration correctly describes the physical configuration of the system and the tasks installed on the Processor module(s). Reset by cycling power and re-loading the configuration and application tasks. For error code EF, un-force the variable and do a STOP ALL from the AutoMax ON LINE PROGRAMMING menu.

## Fatal Errors

The following error codes usually indicate that the runbase is not functioning correctly. If any of these error codes appears, the configuration task and all application tasks are deleted from the Processor module.

F0-F9	Fatal error
FA-FF	Fatal error

Corrective action: cycle power. Re-load the configuration task and all application tasks. Replace the Processor module.

## Informational Messages

The following codes signify a particular condition, not necessarily an error.

dd	This Processor module has successfully completed power-up diagnostics and is waiting for other Processor modules to complete their diagnostics
----	--

- L0 The runbase needs to be loaded onto the rack
- b0 Rack configuration is being validated
- d0 Application task installation in progress
- d1 Waiting on synchronizing event (in a rack with multiple processors)
- d2 Waiting on mutual exclusion lock (in a rack with multiple processors)

Corrective action for b0 and d0 that do not change or disappear: re-load configuration file and application tasks.



# Appendix F

## Using Modems with AutoMax Systems

This section describes how to connect a local personal computer to a remote rack through modems. The term "local" is used to denote the location of the personal computer from which you will communicate through modems. The term "remote" is used to denote the location of the rack with which you will communicate through modems.

Note that this section describes how to connect modems to the "PROGRAMMER/PORT B" port, not the ports in the rack available to the user. See Appendix C for connections to user ports.

The instructions below assume the use of Hayes modems or Hayes compatible modems. Refer to J-3684 or J-3750 for information on connecting and disconnecting the personal computer and the Processor.

### Installing the Modem at the Remote End

The instructions below assume that the remote rack already contains a runbase, or operating system.

1. If you have not already done so, connect a personal computer to the "PROGRAMMER/PORT B" port on the left-most Processor module in the rack.
2. Run the AutoMax Programming Executive.
3. Select the On-Line Programming menu.
4. Select the Connect menu.
5. Select Baud Rate.
6. Using the up and down arrow keys, choose the baud rate that matches the baud rate of the modem you will be using.
7. Press <CR> to select the baud rate.
8. Disconnect the cable between the Processor and the personal computer.
9. Set the modem to auto-answer mode.
10. Connect the modem to the telephone line and to the same Processor port used for the personal computer. The cable between the DB-25 connectors on the modem and the Processor uses straight wiring for pins 2, 3, and 7.

### Accessing a Rack by Modem

1. Edit the file BAUDRATE.INI in the AMX2 subdirectory (for Version 2.0 systems) or AMX3 for Version 3.0 systems on the local personal computer.
2. Assign "NORM" to the modem baud rate. For a 1200 baud modem, you would select NORM=1200. The modem attached to the local personal computer must be at the same baud rate as the modem on the remote connection.
3. Attach a modem to the personal computer port COM1 or COM2. Attach the modem to a phone line.
4. If you have not already done so, run the AutoMax Executive.
5. Select Communication Interface (F6) (AutoMax V2.X) or select Kermit from the command menu (AutoMax V3.X)

6. At the prompt "Kermit-ASD>", enter the following:  
SET PORT COM1 <CR>  
SET SPEED ##### <CR> (where ##### is the modem baud rate)  
C <CR>
7. Dial the phone number of the remote rack's modem by entering one of the following commands:  
AT DT ###-#### (tone-capable phone line; where ###-#### is the remote rack modem's phone number) or  
AT DP ###=#### (pulse-dial only line; where ###-#### is the remote rack modem's phone number)
8. When the remote modem answers and the connection has been completed, return to the AutoMax menu by typing the "Ctrl" and "]" keys at the same time.
9. Enter C.
10. Enter Q <CR>.
11. Select On-Line Programming. This completes the connection between the local personal computer and the remote rack.









**[www.rockwellautomation.com](http://www.rockwellautomation.com)**

---

**Power, Control and Information Solutions Headquarters**

Americas: Rockwell Automation, 1201 South Second Street, Milwaukee, WI 53204-2496 USA, Tel: (1) 414.382.2000, Fax: (1) 414.382.4444

Europe/Middle East/Africa: Rockwell Automation NV, Pegasus Park, De Kleetlaan 12a, 1831 Diegem, Belgium, Tel: (32) 2 663 0600, Fax: (32) 2 663 0640

Asia Pacific: Rockwell Automation, Level 14, Core F, Cyberport 3, 100 Cyberport Road, Hong Kong, Tel: (852) 2887 4788, Fax: (852) 2508 1846