

APPLICATION

This thermostat provides energy saving heating/cooling control for a Mastertrol® Mark II or a Minizone control panel in a zoning system. See Table 1 for model details.

This thermostat is powered direct from transformer, requiring two wires to system transformer.

Heat and cool anticipation is fixed; no adjustment is necessary. Cycle rates are adjustable for heating.

The current rating is 1.6 A maximum at 24 Vac.

Intelligent Recovery™/Conventional Recovery selection screw is included on back of thermostat.

TABLE 1—THERMOSTAT MODEL.

THERMOSTAT	STAGES		SWITCHING		APPLICATION
	HEAT	COOL	SYSTEM	FAN	
T8601C	1	1	HEAT-OFF-COOL	ON-AUTO	Zone 1; conventional heat-cool. Use T8602D, T8603D or T87F for other zones.

INSTALLATION

WHEN INSTALLING THIS PRODUCT...

1. Read these instructions carefully. Failure to follow them could damage the product or cause a hazardous condition.

2. Check the ratings given in the instructions and on the product to make sure the product is suitable for your application.

3. Installer must be a trained, experienced service technician.

4. Allow thermostat to warm to room temperature before operating.

5. After installation is complete, check out product operation as provided in these instructions.

they are flush to the wall surface. Thread wires through the center opening of the wallplate. Then, mount the wallplate using two screws provided. Gently tighten screws, level top surface of wallplate, then securely tighten screws.

CAUTION

1. Disconnect power supply to prevent electrical shock or equipment damage.
2. Push excess wire back into the hole, and plug hole with nonhardening caulk, putty or insulation to prevent drafts from affecting thermostat operation.

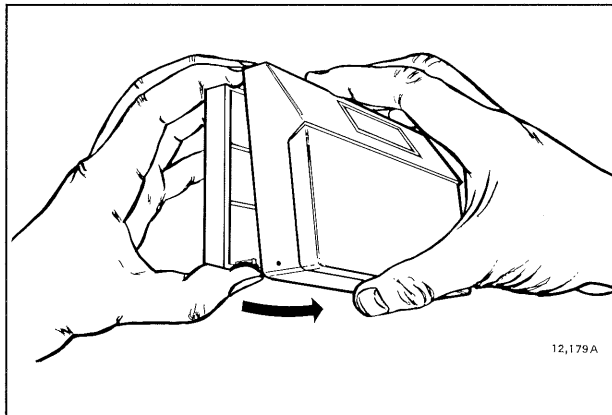

Fig. 1—Removing thermostat from wallplate.

LOCATION

Install thermostat and wallplate about 5 ft. [1.5 m] above the floor in an area with good air circulation at room temperature.

Do not install the thermostat where it may be affected by—

- drafts or dead spots behind doors, in corners, or under cabinets.
- hot or cold air from ducts.
- radiant heat from sun or appliances.
- concealed pipes and chimneys.
- unheated (uncooled) areas behind the thermostat, such as an outside wall.

Run cable to a hole at the selected wall location, and pull about 3 in. [76 mm] of wire through the opening. Color-coded, 18 gauge thermostat cable with at least one conductor for each wiring terminal is recommended.

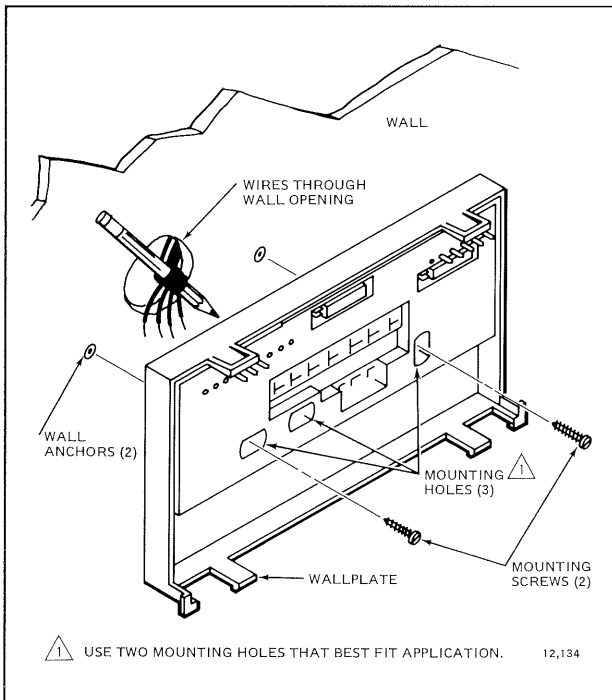

Fig. 2—Mounting wallplate on wall.

MOUNTING WALLPLATE

Remove thermostat from wallplate (Fig. 1).

The wallplate does not require leveling for operation, but for appearance only. The wallplate mounts directly onto the wall with the screws included in the package. Use the wallplate as a template, and with a pencil, mark two mounting screw positions that fit application using two of the three mounting holes in the wallplate (Fig. 2). Use 3/16 in. bit to drill holes for anchors. Gently tap anchors into holes until

WIRING

All wiring must comply with local electrical codes and ordinances.

Disconnect power before wiring to prevent electrical shock or equipment damage.

The shape of the terminal barrier permits insertion of straight or conventional wraparound wiring connections. Either method is acceptable.

Refer to Fig. 4 for typical wiring diagram.

NOTE: Restrict all wiring to ribbed area surrounding terminals (Fig. 3) to assure thermostat/wallplate contact.

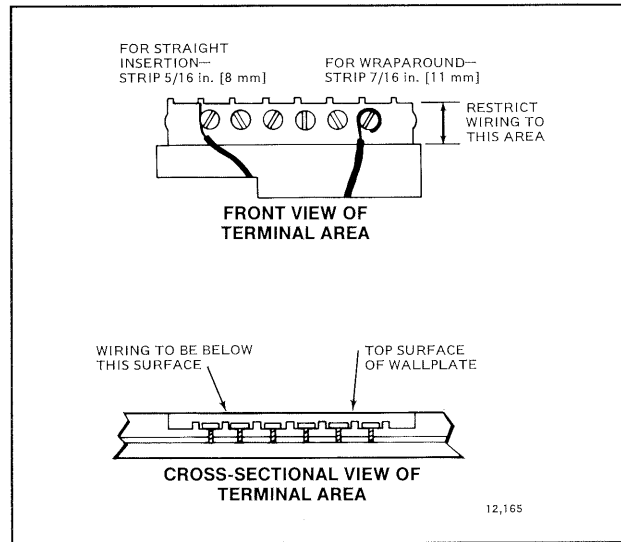

Fig. 3—Restrict wiring to ribbed area surrounding terminals.

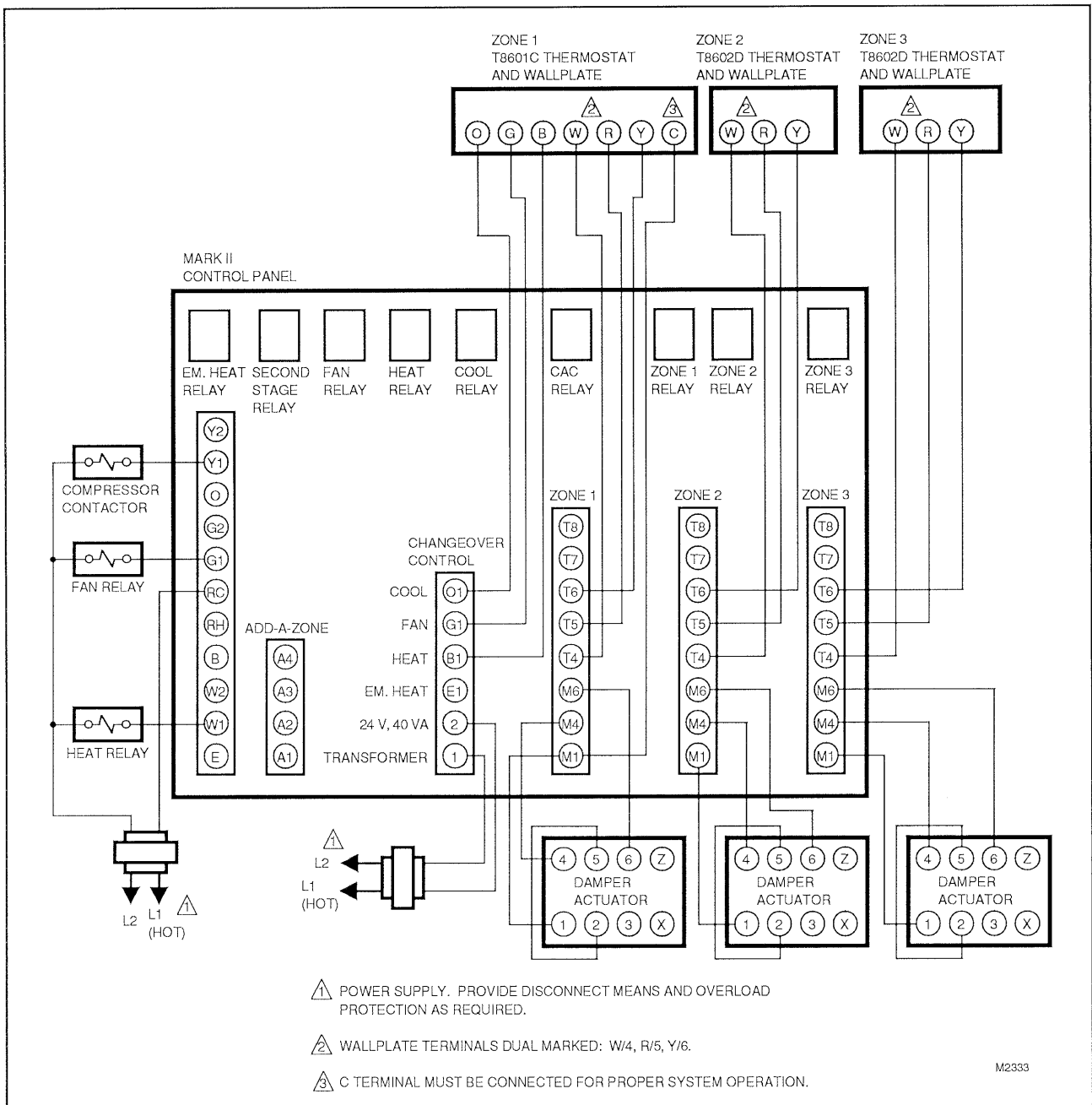

Fig. 4—Typical wiring diagram for T8601C, T8602D zoned heating/cooling system.

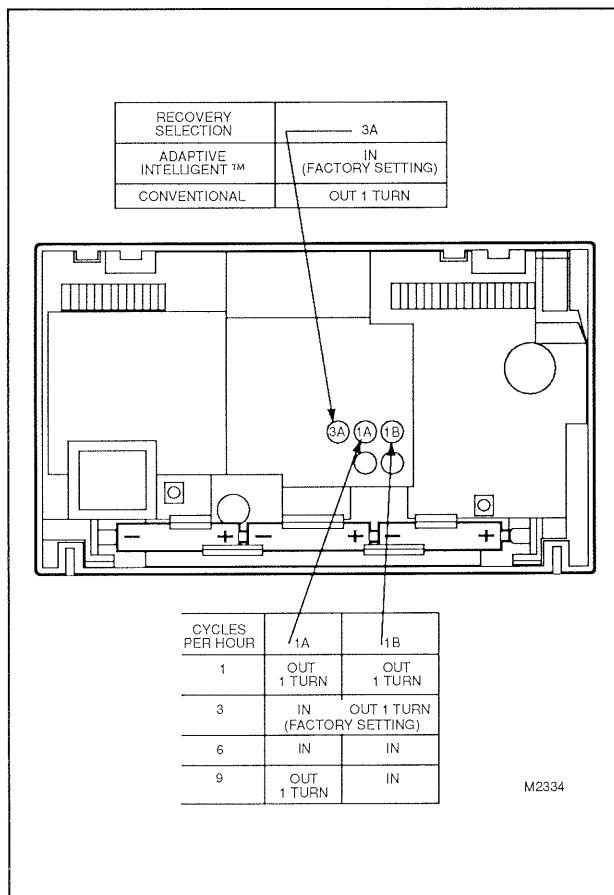

Fig. 5—Cycle rate and energy savings mode adjustment.

CYCLE RATE ADJUSTMENT

NOTE: MOST APPLICATIONS WILL NOT REQUIRE A CHANGE IN CYCLE RATE.

The room air temperature will vary slightly from the comfort temperature setting with the cycling of the furnace or air conditioner. The equipment cycles off and on as room temperature approaches the set point.

The cycle rate of this thermostat is set for heating at three cycles per hour and for cooling at three cycles per hour as shipped from the factory. The cooling cycle rate can not be adjusted. The heating cycle rate can be adjusted by turning one or both cycle rate adjustment screws located on the back of the thermostat. See Fig. 5. The screws should only be backed out about one turn, or be turned in until tight.

ADAPTIVE INTELLIGENT RECOVERY™/CONVENTIONAL RECOVERY CONVERSION

The thermostat is factory-set for Adaptive Intelligent Recovery™, but may be converted to conventional recovery using screw 3A on the back on the thermostat as indicated in Fig. 5.

With Adaptive Intelligent Recovery™, the room will reach the comfort temperature at the exact time programmed into the thermostat. Because the control temperature changes gradually, the equipment will turn on and off several times to reach the comfort temperature slowly and on time. There will be no wasting of energy associated with rapid temperature changes and temperature overshoot.

With conventional recovery, the start time should be programmed to be earlier than the desired comfort time. In this mode, the start time indicates when the heating or cooling equipment comes on to start recovery. The equipment will stay on until the comfort temperature is reached.

INSTALLING BATTERIES

Three AAA alkaline batteries are provided as backup to prevent program loss in case of power outage. Batteries are included with thermostat. Install batteries in back of thermostat as shown in Fig. 6.

Without battery backup, the program will remain about 30 seconds in event of power loss.

IMPORTANT

- When batteries are first installed, the display will flash -AC until the thermostat is powered from the system wiring.
- If AC power is lost during operation, the display will show -AC instead of temperature.

MOUNTING THE THERMOSTAT

Hang the thermostat on the tabs at the top of the base (Fig. 7a). Swing down and press on lower edge until thermostat snaps in place (Fig. 7b). Open cover, and tighten the captive mounting screws (Fig. 7c).

When 24 V system power is present, the room temperature will be displayed.

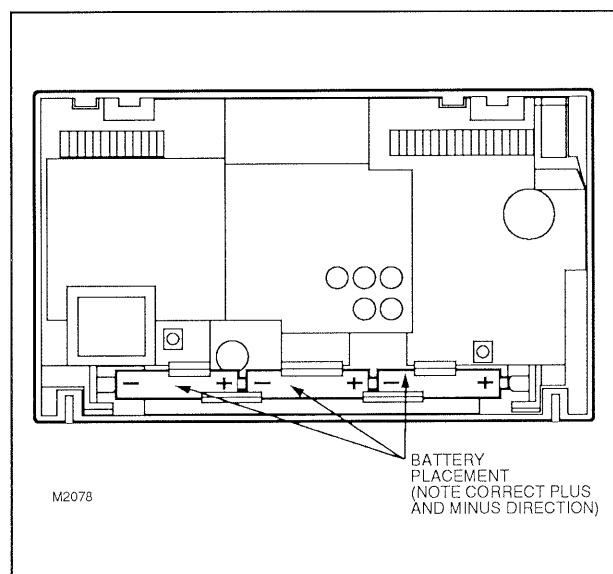

Fig. 6—Battery placement.

SETTING DAY AND TIME

Set present day and time as follows:

Press .

Press TIME  or  to set the current time.

Press .

Press  to set the current day. Each press of the

DAY KEY advances the display one day.

NOTE: When 24 V is first applied to power unit, display will flash 1:00 PM and 32° for a minute or less, followed by 1:00 and the room temperature flashing.

If the display will not come on:

- check mounting of thermostat to wallplate. If loose or misaligned, remove thermostat and reinstall on the wallplate, making sure it is firmly attached.
- check to see that heat or cool system power is on.
- check voltage between R and C; should be 24 to 30 Vac. Display will show -AC if no 24-30 Vac.

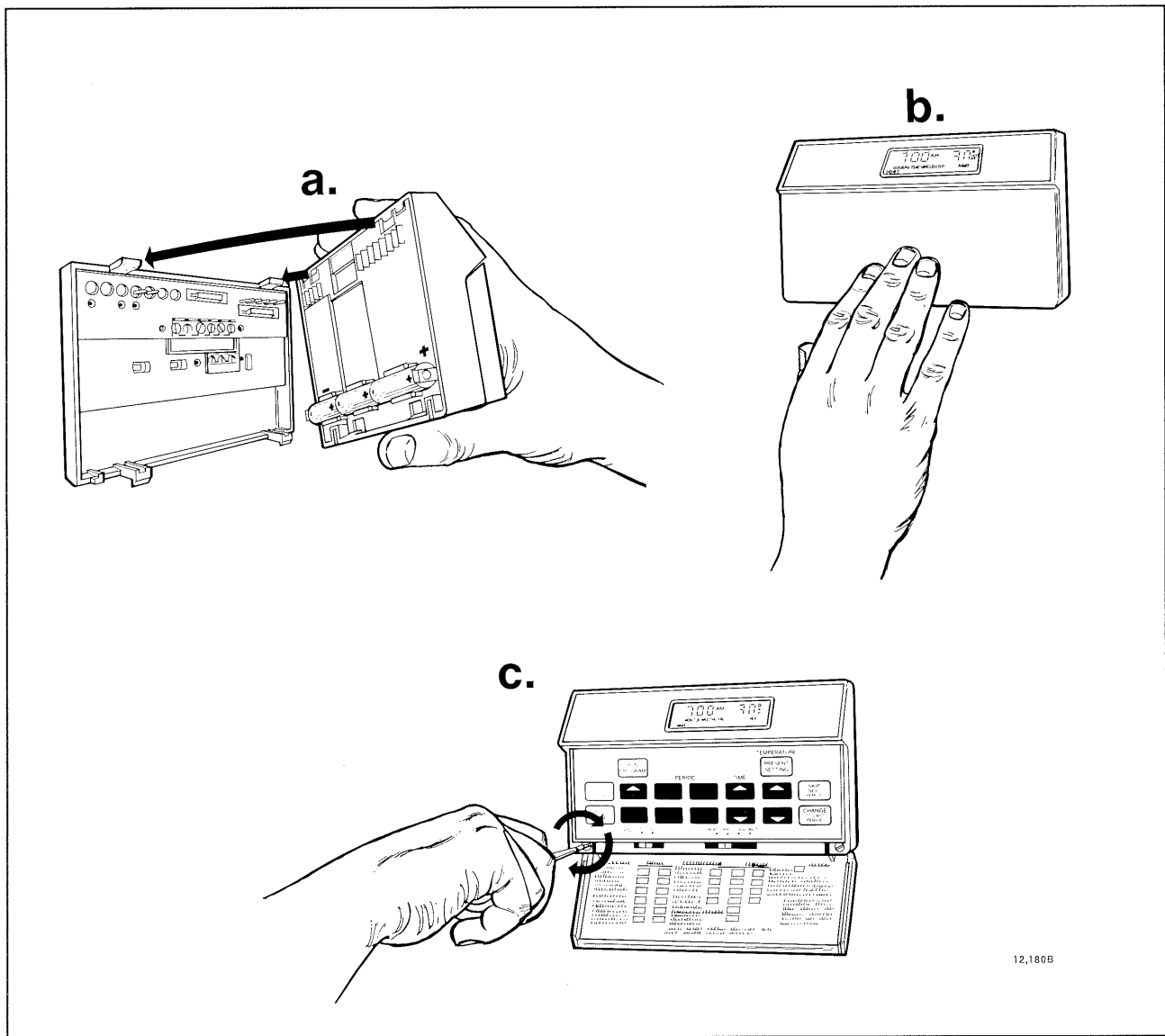

Fig. 7—Mounting thermostat on wallplate.

CHECKOUT

When installation is complete, turn on power supply and check thermostat operation as follows. For complete checkout of entire zone system, refer to system specification, Honeywell Form No. 68-0101.

HEATING

Check Zone 1

1. Set the T8601C thermostat system switch to HEAT and fan switch to AUTO.
2. Press T8601C WARMER key until the setting is about 10° F [6° C] above room temperature to call for heat.
3. On other zone thermostats, adjust each thermostat until each setting is about 10° F [6° C] below room temperature.

Reaction

1. The T8601C zone damper should remain open; other zone dampers should close. Dampers may take up to 30 seconds to open or close fully.

NOTE: If Mastertrol® Mark II panel is used, any zone damper can be set to close when the system is satisfied; when any other zone thermostat calls for heat, that damper will remain closed.

2. Furnace should start immediately; fan should start after a short delay.

Check Other Zone

To check zones other than zone 1, refer to the Checkout section of the installation instructions included with the thermostats for other zones.

End Heating Checkout

Press T8601C COOLER key until the setting is about 10° F [6° C] below room temperature to end call for heat.

Reaction

Unless another thermostat other than the T8601C thermostat is calling for heat, the furnace should shut off; fan should shut off after a short time. All dampers should open unless set to closed on the Mastertrol® Mark II panel.

COOLING

CAUTION

Do not operate cooling equipment if outdoor temperature is below 50° F [10° C]. Refer to manufacturer's recommendations.

Check Zone 1

1. Set the T8601C thermostat system switch to COOL and fan switch to AUTO.
2. Press T8601C COOLER key until the setting is about 10 F [6 C] below room temperature to call for cooling.

3. On other zone thermostats, adjust each thermostat until each setting is about 10° F [6° C] above room temperature.

Reaction

1. The T8601C zone damper should remain open; all other zone dampers should close. Dampers may take up to 30 seconds to open or close fully.

NOTE: If Mastertrol® Mark II panel is used, any zone damper can be set to close when the system is satisfied; when any other zone thermostat calls for cool, that damper will remain open.

2. Cooling system and fan should come on.

Check Other Zone

To check zones other than zone 1, refer to the Checkout section of the installation instructions included with the thermostats for other zones.

End Cooling Checkout

Press T8601C WARMER key until the setting is about 10° F [6° C] above room temperature to end call for cooling.

Reaction

Unless another thermostat other than the T8601C thermostat is calling for cooling, cooling and fan should shut off. All damper should open unless set to closed on the Mastertrol® Mark II panel.

FAN

1. Set fan switch on T8601C thermostat to ON, system switch to OFF. Fan should run continuously.

2. Move the fan switch to AUTO; fan operation is now controlled by the plenum fan control in heating and by the thermostat in cooling.

INSTALLER SELF-TEST (optional)

Perform the following test as a check of all thermostat functions. *If thermostat does not respond as indicated, thermostat must be replaced.*

1. Press AHEAD and BACK keys at the same time. While holding keys down, all segments of the display should be on (see Fig. 8).

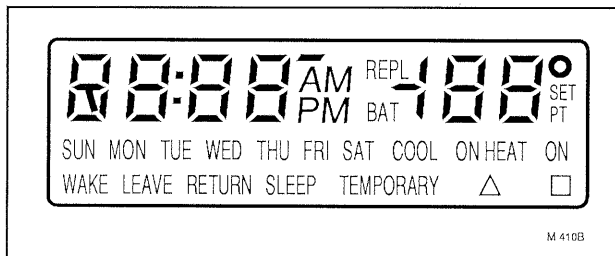

Fig. 8—All segments on display.

2. Set system switch to OFF, where applicable. Press AHEAD and BACK and PRESENT SETTING keys at the same time to enter self-test.

3. Press each key as listed below, and look for responses listed, as key is held down and released.

PRESS THIS KEY	LOOK FOR THIS RESPONSE	
	KEY DOWN	KEY RELEASED
PRESENT SETTING	15	see note a below
SKIP NEXT PERIOD CHANGE TO LAST PERIOD	07	blank
COOLER	03	blank
WARMER	02	blank
BACK	06	blank
AHEAD	04	blank
RETURN	05	blank
LEAVE	00	blank
SLEEP	01	blank
WAKE	08	blank
SET HEAT/COOL DAY	12	see note b below
	09	blank
	13	micro-processor mask number and revision number
HOLD	10	blank
SET PRESENT DAY/TIME	14	see note c below
RUN PROGRAM	11	normal operating display

^aThe cooling system comes on when the key is released (on T8601C, system switch must be in COOL.) Press and release to turn cooling system off.

CAUTION

Do not operate cooling if outdoor temperature is below 50° F [10° C]. Refer to manufacturer's recommendations.

^bA four-digit code number will appear when the key is released. The four digits of the code represent the following options.

FIRST DIGIT	HEATING CYCLES PER HOUR AT 50% ON TIME SET FOR
0	1
2	3 (factory setting)
4	6
6	9

SECOND DIGIT	CLOCK (HR.)	DEGREES	RECOVERY TYPE
0	12	F	Conventional
2	12	F	Adaptive Intelligent™

THIRD DIGIT	THERMOSTAT TYPE	SYSTEM SWITCH POSITION
0	Heat/Cool	Off
2	Heat/Cool	Cool
4	Heat/Cool	Heat

FOURTH DIGIT	AUTO OR MANUAL CHANGEOVER	SYSTEM SWITCH
4	Manual	All Positions

°The heating system comes on when the key is released (on T8601C, system switch must be in HEAT.) Press and release again to turn heating system off.

ALLOW THERMOSTAT TO REACH ROOM TEMPERATURE BEFORE PROGRAMMING. THEN, REFER TO OWNER'S MANUAL FOR PROGRAMMING INSTRUCTIONS AND HOMEOWNER TROUBLESHOOTING.

This equipment is a Class B digital apparatus which complies with Canadian Radio Interference Regulations, CRC c.1374.

Honeywell Inc.
U.S.A.: 1885 Douglas Drive N.
Golden Valley, MN 55422-4386
CANADA: 740 Ellesmere Road
Scarborough, Ontario M1P 2V9

International Sales Offices in all principal cities of the world. Manufacturing in Australia, Canada, Finland, France, Germany, Japan, Mexico, Netherlands, Spain, Taiwan, United Kingdom, U.S.A.



QUALITY IS KEY

PRINTED IN TAIWAN R.O.C.