

ADT-MP3

User Manual



ADT-MP3



User Manual

All rights reserved.

Improvement and changes to specifications, design and this manual, may be made at any time without prior notice.

CE 24-004-2865-00
Rev1.0

It is important to read this instruction book prior using your new product for the first time.

Table of Contents

Introduction.....	1
Delivery Packet.....	1
Features.....	1
Specification.....	2
Physical Dimensions.....	2
Control Panel View.....	3
Rear panel View.....	5
Operation Guide	
Manual Conventions.....	6
MODE.....	6
1. MP3 MODE.....	6
2. PRESET MODE.....	6
3. MAIN MENU.....	7
3.1. DATE & TIME.....	7
3.2. SCENE EDIT.....	8
3.2.1. MUSIC SETTING.....	8
3.2.2. LED.....	9
3.2.3. 6 CHANNEL DMX.....	9
3.3. EVENT EDIT.....	11
3.4. SET OFF DELAY.....	13
3.5. SET PASSWORD.....	14
Operation on MP3 Player.....	15
1. MP3 MENU INSTRUCTIONS.....	15
2. BROWSE.....	15
3. FUNCTION MODE.....	16
5. PLAYBACK Submenu.....	16
4. PLAYBACK MODE.....	17
Remote Controller Operation.....	18
Appendix I	
Junction Box Instructions.....	21
Appendix II	
Menu Chart.....	23

Appendix II

5.)Set Password

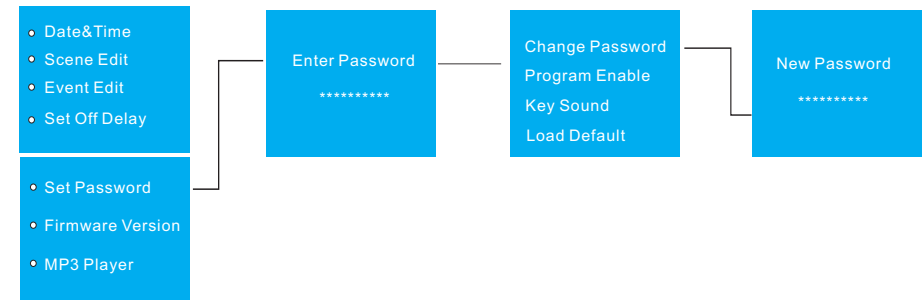

6.)Firmware Version

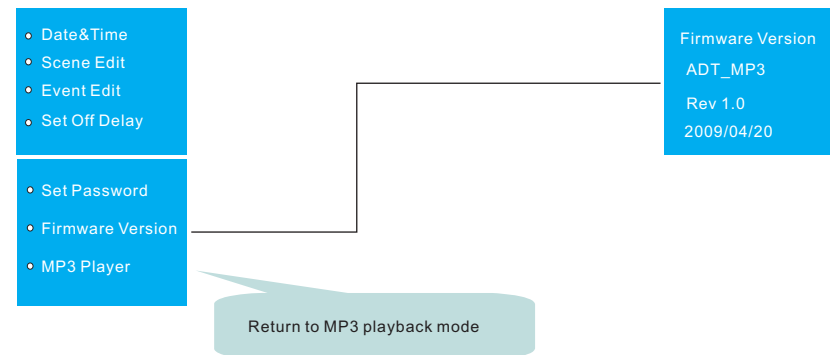

Appendix II

3.)Event Edit

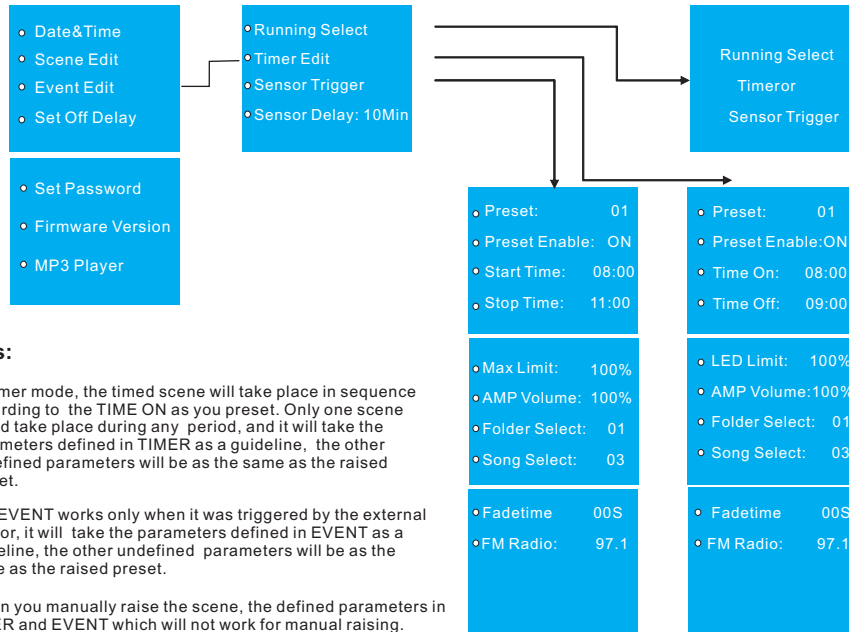

Rules:

- In timer mode, the timed scene will take place in sequence according to the TIME ON as you preset. Only one scene would take place during any period, and it will take the parameters defined in TIMER as a guideline, the other undefined parameters will be as the same as the raised preset.
- The EVENT works only when it was triggered by the external sensor, it will take the parameters defined in EVENT as a guideline, the other undefined parameters will be as the same as the raised preset.
- When you manually raise the scene, the defined parameters in TIMER and EVENT which will not work for manual raising.

4.)Set Off Delay

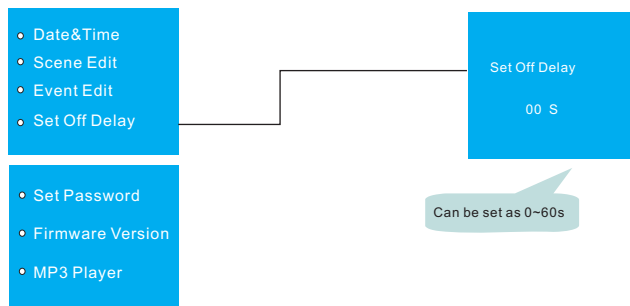

Introduction

Congratulations and thank you for purchasing our ADT-MP3. The ADT-MP3 is a combination of built-in MP3 player and amplifier with touch interface. It is compact and easy to operation.

Delivery Packet

Check for transport damage. You should be in possession of the following items:

- | | |
|--------------------------|--------------------|
| 1 ADT-MP3 | 1 Manual |
| 1 Man-body moving sensor | 1 Junction Box MP3 |
| 1 LED remote controller | |

Should you discover transport damage after unpacking the equipment, inform the hauler immediately. Never connect a damaged device. You may also contact your supplier.

Features

- Touch interface.
- Built-in MP3 player
---- Allows to transmit and save music files via USB or MICRO SD card.
- Built-in amplifier
---- Enables to drive external speaker directly(10W single track).
- AUX input ---- Automatically switch to external output once has AUX input.
- 3 channels PWM output drive 3 ways LED,
---- 380MA per channel, 1.2 A in total(trough network line).
- Allows to save and play 9 scenes, including the control for built-in MP3 player and amplifier(such as song selection and volume level, etc.).
- 3 ways LED output, 6 channels DMX, the fadetime can be set separately for each scene .
- External Man-body moving-sensor triggers scene output(lighting and music).
- Enables to set the program of playback different scene in different period, the limitative brightness , music volume in specified period, and the fade time of playback or shutdown a scene.
- Timing function----Each scene can be set to timed start or shut.
- Emergency trigger function (links to the fire alarm contact)
- Infrared remote control.
- Function memory and Power failure protection.

Specification

Power Supply.....	JUNCTION BOX MP3
Speaker/Power Consumption.....	10W Single Track
Output.....	3CH PWM output,380mA/CH, Total 1.2 A
3Way LED Output
6CH DMX Output
IR EYE sensor
External Man-Body moving-sensor triggers scene output
Housing.....	Plycarbonate
Connector.....	2 RJ45 ports
Operation Temperature.....	0 degC~+40 degC
Storage Temperature.....	-20 degC ~ +70 degC
Accessories.....	Remote Controller(including)
Dimensions.....	76 x 120 x 15.5(mm)
Weight.....	230g

Physical Dimensions

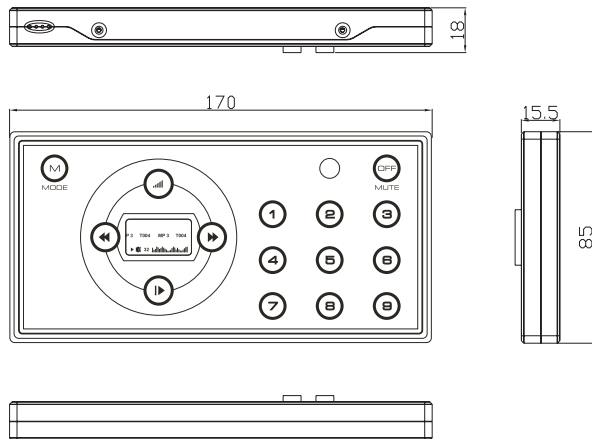

Appendix II

MENU CHART

1.)Date & Time

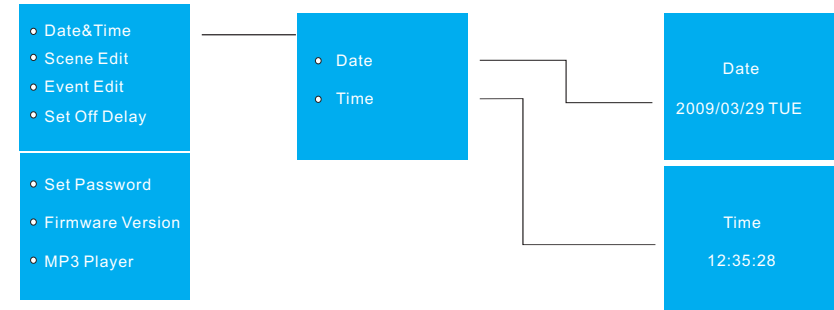

2.)Scene Edit

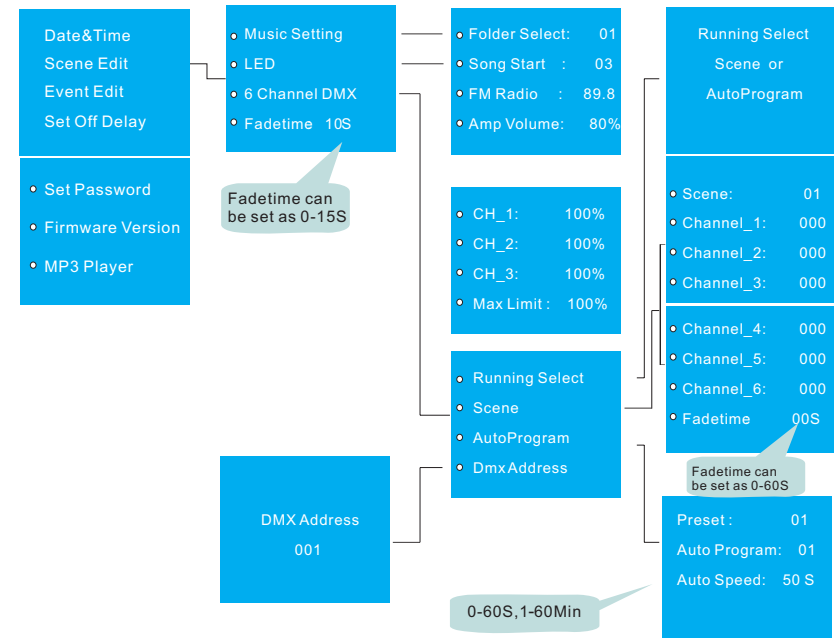

Appendix I

6.LED Out

Dimmable port for 3 ways LED(Driven by PWM), 380mA per channel, 1.2A max.

7.Sensor

The input port for the external Man-body moving sensor module. It is important to distinguish the input end for power, earthed and signal prior to link moving sensor with it.

8.EMERGENT CONTACT

The emergent contact which links the fire alarm.

9.EMERGENT CONTACT SET

Can be set as NC(normal close) and NO(normal open).

When set it as NC, the emergent contact is closed in normal state. Once a fire alarm happened, the emergent contact disconnects and the device goes into emergent state. At this time, all of the LEDs lit and the amplifier is in mute.

When set it as NO, the emergent contact is open in normal state. Once a fire alarm happened, the emergent contact closes and the device goes into emergent state. At this time, all of the LEDs lit and the amplifier is in mute.

Once the fire alarm was canceled, if want return to normal working state, the user may press the power button to power off the unit, and then power on it, the unit will exit the fire alarm state and go into normal working state.

Control Panel View

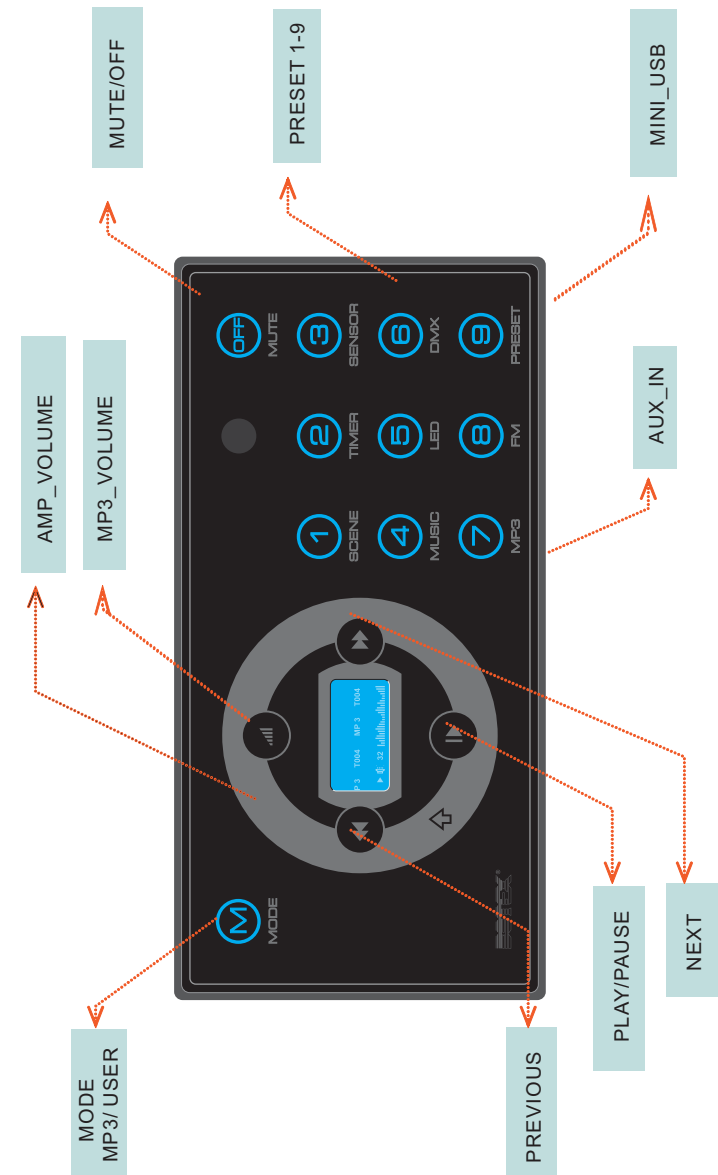

Control Panel View

1.MODE Button

Used to alternate the working mode, confirm your selection and enter into the next menu, hold on press it will return to the main menu.

2.Touch Toggle

Master controller. Controls the value of PWM, Volume, fadetime, etc.

3.MUTE(OFF) Button

Used to mute or off the unit.

4.Button 1~9

Used to play and store the built-in 9 scenes.

5.PLAY Button "▶"

Used to power on device, play and stop MP3 player.

6.VOLUME Button "🔊"

Used to enter into the volume adjustment interface.

7.NEXT Button "▶▶"

Used to enter into the next item, forward, increase volume.

9.PRV Button "◀◀"

Used to go back to the last item, backward, decrease volume.

10.SHIFT Button "⇧"

Used to enter into the menu of SCENE, TIMER, SENSOR, MUSIC, LED, DMX, MP3 ,FM and PRESET.

11.LCD

Displays the current working state.

12.INFRARED SENSOR

Receives the signal from the external remote controller.

13.USB Port

Used to connects your PC for transmit music files.

14.AUX IN

Used to connects the external audio source.

Appendix I

JUNCTION BOX MP3 INSTRUCTIONS

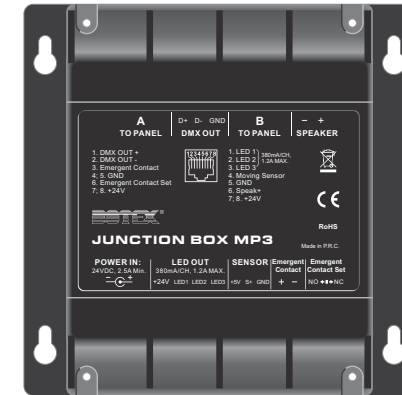

1.Port A

Connects the port A of ADT-MP3. It's configuration as following.

1 = DMX OUT +	4,5 = GND
2 = DMX OUT -	6 = Emergent Contact Set
3 = Emergent Contact	7,8 = +24V

2.Port B

Connects the port B of ADT-MP3. It's configuration as following.

1= LED 1	5= GND
2= LED 2	6= Speaker +
3= LED 3	7,8= +24V
4= Moving Sensor	

3.DMX Out

Outputs 6 channels DMX signal.

4.Speaker +, -

Connects the external speaker box.

5.Power In

Power Input port, 24V DC, 2.5A Min.

Operation Guide

NOTE:

- 1) Effective distance from ADT-MP3 to LED Remote controller shall be limited within the range of 6m. Otherwise, it results out of control.
- 2) "PRESET + 1~9": Press PRESET firstly, and press the figure button 1~9 may raise the PRESET 1~9.
- 3) "FREQ + x+x+x" / "x+x+x+x": Press FREQ firstly, and then press the followed figure button orderly, this function is only available in the range of 870~1080. For example, press "FREQ+8+9+8" you can enter into FM menu and it's frequency is 89.8MHZ.
- 4) "FOLDER + x / x+x": Press FOLDER firstly, and then press the figure button you can select to play the folder from local memory or SD card folder 1~8.

For example,

- a.) Press FOLDER+1~8, you can go to the local memory folder MUSIC1~8;
- b.) Press FOLDER+01~08, you can go to the SD card folder MUSIC1~8.

Audio Repeat

While the ADT MP3 is playing the folder MUSIC1~7, the player will repeat playback MUSI1~7. While the unit is playing the folder MUSIC8, the player will repeat playback the current song. As the following form shows,

PLAY MODE	AUDIO REPEAT
ADT MP3 is playing MUSIC1~7	Folder(MUSIC1~7)
ADT MP3 is playing MUSIC8	The current song

Special Note:

The folder name must be named as MUSIC1, MUSIC2, MUSIC3, MUSIC4, MUSIC5, MUSIC6, MUSIC7, MUSIC8 in both local memory and SD card prior to save your music files into the folder. Otherwise, your music file can't be read by MP3 player.

5) "SONG + x+x": Press SONG firstly, and then press the followed figure button you can select the music from the current folder. If you want to select the 8th music from the current folder, you must press SONG+0+8, the music will be raised and played. Otherwise, your selection will be void.

6) Press Scan, the unit automatically starts to search the broadcasting station. After the scanning complete the unit will reserve those found stations, back to FM mode, and then locate the first station.

Rear Panel View

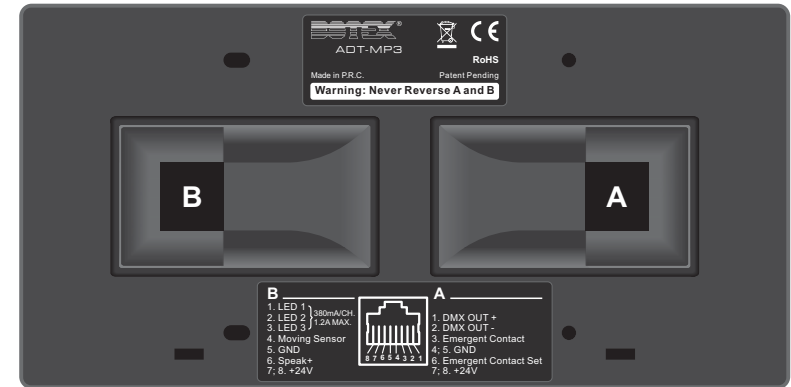

1.Port A

Connects the port A of Junction Box Mp3. It's configuration as following.

- | | |
|----------------------|--------------------------|
| 1 = DMX OUT + | 4,5 = GND |
| 2 = DMX OUT + | 6 = Emergent Contact Set |
| 3 = Emergent Contact | 7,8 = +24V |

2.Port B

Connects the port B of Junction Box Mp3. It's configuration as following.

- | | |
|-------------------|---------------|
| 1 = LED 1 | 5 = GND |
| 2 = LED 2 | 6 = Speaker + |
| 3 = LED 3 | 7,8 = +24V |
| 4 = Moving Sensor | |

Operation Guide

MANUAL CONVENTIONS

The following conventions are used throughout this manual.

Tap is an act of pressing any buttons, the button takes effects immediately.

Press is an act of pressing any buttons, the button dose not take effects until release the fingers.

Hold on Press is an act of pressing any buttons for 1.2 seconds or above till the button takes effects.

MODE

The ADT-MP3 is available in MP3 MODE and PRESET MODE, the following contents detailed the information.

1. MP3 MODE

In MP3 Mode, the user may use the touch toggle to control the output volume of the amplifier.

By means of the button(Like as MODE, PLAY, VOLUME, PREV and NEXT) in the interface, the user may use the unit as a normal MP3 player.

The users may use the button 1~9 to raise the assigned value , including the value of the 3channles LED dimmer, 6channels DMX, PWM, volume, song selection, fadetime, etc.

The detail information you can refer to "**OPERATION ON MP3 PLAYER**" on page 13.

2. PRESET MODE

Hold on press Shift button(⇧), meanwhile to **tap** button 1~9, the user may enter into the corresponding function mode---SCENE, TIMER,...PRESET.









Once entered into the menu you desired, you may

- 1)press its button for 2 seconds, the parameter you set which will be saved in the Scene.
- 2)tap its button, you can raise the prior value.

Operation Guide

Keys

Functions

ON/OFF 	Powers on or off the unit.
Button 0~9	May be used with the key of Preset,FREQ,Folder,Song.
FREQ	"FREQ+x+x+x/x+x+x+x" to select frequency.
SONG	"SONG+x+x" to select the song you want to play.
PRESET	PRESET+"1~9" to raise the PRESET 1~9.
BEEP	Switches key tone between on and off.
VOLUME + 	Holding the key down will gradually increase to the maximum value of volume.
VOLUME - 	Holding the key down will gradually decrease to the minimum value of volume.
PREV 	In MP3 mode, it is used to select the previous music or backward. In preset mode, it is used to select the option .
NEXT 	In MP3 mode, it is used to select the next music or forward . In preset mode, it is used to select the option .
PLAY/STOP 	In MP3 mode, it is used to play or pause the MP3 player. In preset mode, it is used to select the option .
MP3	Selects MP3 mode.
FOLDER	"FOLDER+x/x+x",Selects Music folder you want to open.
FM	Selects FM mode.
BRIGHTNESS 	Increases to the value of Brightness for the external 3 ways LED.
BRIGHTNESS 	Decreases to the value of Brightness for the external 3 ways LED.
SCAN	Automatically scanning the broadcasting station.
MUTE	Mutes the audio output, tap it again will resume audio output.

Operation Guide

Remote Controller Operation

A built-in IR EYE sensor enables you operator your ADT-MP3 by remote controller.

Operation Instructions

1. Before operation, make sure the batteries(3V, CR2025) have been installed into the remote controller properly.
2. There are 10 dedicated figure(0~9) keys, FREQ, SONG, ON/OFF, PRESET, BEEP, VOLUM+/-, PREV, NEXT, PLAY,MP3, FOLDER, FM, BRIGHTNESS +/-, MUTE, SCAN & MUTE keys on the remote controller interface.

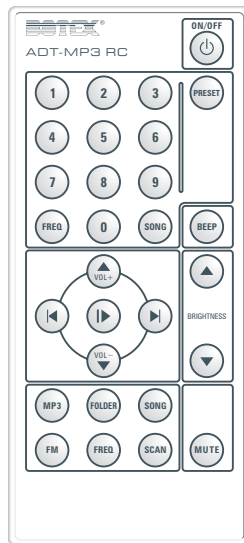

ADT-MP3 Remote Controller

The detailed function will be illustrated in the following table.

Operation Guide

3. MAIN MENU

Press Shift + PRESET(button 1) to enter into main menu, the LCD shows you as below.

- Date & Time
- Scene Edit
- Event Edit
- Set Off Delay

- Set Password
- Firmware Version
- MP3 Player

3.1) Date & Time

In Date & Time submenu, you can separately set the Date and Time by tap the VOLUME , PRV or NEXT button.

- Date
- Time

To select and enter into Date, the LCD shows you as below. Now the user can tap the VOLUME button to move the cursor, and use PRV or NEXT button to adjust the year, month and date .

Date
2009/03/29 TUE

To select and enter into Time, the LCD shows you as below. Now the user can tap the VOLUME button to move the cursor, and use PRV or NEXT button to adjust the hour, minute and second .

Time
12:35:28

Operation Guide

3.2) SCENE EDIT

To select and enter into SCENE EDIT Submenu, the LCD shows you as below.

- Music Setting
- LED
- 6 Channel DMX
- Fadetime: 10S

The user may preset the music, the external LED (driven by 3 channels PWM), the 6 channels DMX and raise the fadetime of the scene in this menu.

The user may tap the NEXT Button "▶▶" or PRV Button "◀◀" move the cursor to select the submenu, and then press MODE button to enter.

3.2.1) Music Setting

- Fold Select: 01
- Song Start: 03
- FM Radio: 89.8
- Amp Volume: 80%

Likewise, the user may tap the NEXT Button "▶▶" or PRV Button "◀◀" move the cursor to select the submenu, and then press MODE button to enter.

The user may operate the following actions:

- Folder Select: selects the music folder you want to use
- Song Start: to select the music you want to play
- FM Radio: to set the frequency of the radio
- Amp Volume: to set the volume of the amplifier

Note: The user may enter into this mode by shortcut of pressing button "Shift + MUSIC" at a time.

Operation Guide

- Repeat
 - Intro

The device allows you select repeat the folder or all music files.

- Equalizer: allows you select the equalizer like Natural, Rock, POP, etc.
- SRS WOW Mode: allows you select the SRS WOW, user settings or Disable SRS WOW.
- Repaly time: allows you set the Replay time
- Replay gap: allows you set the Replay gap
- Exit: goes back MP3 interface

5. PLAYBACK MODE

The above operation may be briefly expressed by the following form.

Button	Act	State Of		Playback Sub-menu	Standby Sub-menu
		Standby	Playing		
Play ▶	Tap	Playback	Stop	Exit from Sub-menu	
Mode	Hold on Press	Enter into main menu			
	Tap	Enter Standby Sub-menu	Enter Playback Sub-menu	Confirm selection or Enter into the next	
Next ▶▶	Tap	Next song	Next song and play	Move the Sub-menu	
	Hold on Press	Keep browsing forward	Forward	Keep moving forward	
Prev ◀◀	Tap	Last song	Last song and play	Move the Sub-menu	
	Hold on Press	Keep browsing backward	Backward	Keep moving backward	
Vol 	Tap	Volume		N/A	

Operation Guide

3. FUNCTION MODE

The user may enter into any function mode from Main Menu.

- Volume Adjustment

Tap VOLUME " " to activate Volume function. Use NEXT " " to increase the volume and PRE " " to decrease the volume.

- On/Off device

While the device is running, **Hold on Press** Play " " button may off the device and enter into Standby. While the device Stand by, **Hold on Press** Play " " button may on the device.

While the device is playing music, **Tap** Play " ", the device pauses playback, While the device is pausing, **Tap** Play " " button to resume playback.

While the device is recording, **Tap** Play " " button, the device pauses record. While the device is in Sub-Menu, **Tap** Play " " button to exit from Sub-menu.

4.PLAYBACK SUBMENU

While the device is playing music, **TAP** Mode you can enter into Playback Submenu.

- Reboot
- Equalizer
- SRS WOW Mode
- Tempo Rate

- Replay
- Replay time
- Replay Gap
- Exit

Use "NEXT" or PREV" select your option, then **Tap** MODE button to enter into Submenu. Choose Reboot, the LCD shows

- Repeat
- Repeat Folder
- Repeat All
- Random

Operation Guide

3.2.2) LED

To select and enter into LED mode, the LCD shows you as below.

- CH_1: 100%
- CH_2: 100%
- CH_3: 100%
- Max Limit: 100%

The user may set the intensity for the external LED (which was driven by 3 ways PWM) and the max intensity.

Note: The user may enter into this mode by shortcut of pressing button "Shift + LED" at a time.

3.2.3) 6 CHANNEL DMX

In main menu, to select and enter into 6 CHANNEL DMX, the LCD shows you

- Running Select
- Scene
- AutoProgram
- DMX Address

Running Select

The Running Select mode allows you separately set the work mode(Scene or AutoProgram) for the 6 channels DMX

- Running Select
- Scene or
- AutoProgram

Operation Guide

Scene

In Scene mode, the 6 channels DMX value and the fadetime(in the range of 0~60 seconds) can be set separately.

• Scene	01
• Channel_1	000
• Channel_2	000
• Channel_3	000
• Channel_4	000
• Channel_5	000
• Channel_6	000
• Fadetime	00S

AUTO_PROGRAM

The user can select the built-in program(1~10) or the auto program. The running speed can be set in the range of 0~60Min.

• Preset:	01
• Auto Program:	01
• Auto Speed:	50 S

DMX Address

The user can set the initial address for the DMX output.

DMX Address
001

Also, the user may enter into 6 Channel DMX mode directly by shortcut of pressing button "Shift + DMX" at a time.

Operation Guide

OPERATION ON MP3 PLAYER

1. MP3 MENU INSTRUCTIONS

The MP3 player menu consists of the Main Menu and Sub-menu, the Sub-menu consists of the Playback Sub-menu(the device is playing music) and the Standby Sub-menu(the device stops playing).

Level 1	Level 2	Level 3
Menu	Main Menu	
	SubMenu	Playback
		Standby

The user may **Hold on Press** the MODE button to enter into main menu. And can use "NEXT" or PREV" select your option, then **Tap** MODE button to enter into submenu.

• Local Folder
• Card Folder
• Delete
• Delete All
• Exit

- Local Folder: shows you the Local music folders
- Card Folder: shows you the music folders in local card
- Delete: deletes a file
- Delete All: delete all files
- Exit: go back to MP3 interface

2. BROWSE

- Browse and select song
 - To **Tap** the PRV " ◀ " button to browse and select the previous song.
 - To **Tap** the NEXT " ▶ " button to browse and select the next song.
- Forward/ Backward while device is playing music
 - To Hold on Press the PRV " ◀ " button to backward.
 - To Hold on Press the NEXT " ▶ " button to forward .

Operation Guide

3.5) SET PASSWORD

It is required to input the user password prior to enter into this submenu.

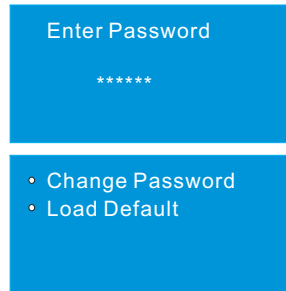

- Change Password: allows you change the user password.

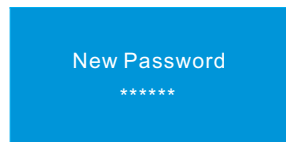

- Load Default: restore all of the parameters as the default setting.

3.6) FIRMWARE VERSION

This submenu is used to view the current software version.

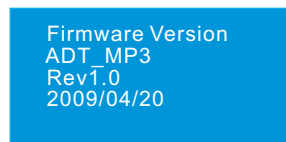

3.7) MP3 PLAYER

This submenu is used to exit the current mode and go back to MP3 mode.

Operation Guide

3.3) EVENT EDIT

In Event Edit submenu, you can select the running program which includes TIMER mode and SENSOR TRIGGER mode. The TIMER mode is used to timed turn on or off the scene. If it is required to turn on or off the scene by triggering the external sensor, you have to choose SENSOR TRIGGER mode.

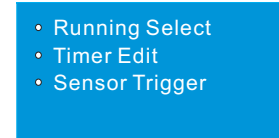

Timer Edit

Entered into timer menu, you may press the button 1~9 to select and edit the assignment of timed trigger the scene .

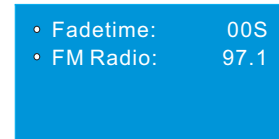
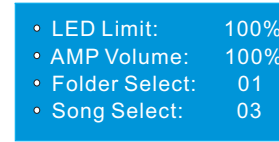
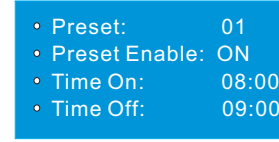

The assignment includes:

- Preset: to select the scene you want to edit
- Preset Enable: to turn on or turn off a scene
- Time On: to set the time of turning on a scene
- Time Off: to set the time of turning off a scene
- LED Limit: to set the max intensity of the LED
- AMP Volume: to set the volume of the amplifier
- Folder Select: to choose the MP3 folder you want to play
- Song Select: to choose the music file you want to play
- Fadetime: to set the fadetime to trigger the scene
- FM Radio: to set the frequency for the radio

Operation Guide

Rules:

- In timer mode, the timed scene will take place in sequence according to the TIME ON as you preset. Only one scene would take place during any period, and it will take the parameters defined in TIMER as a guideline, the other undefined parameters will be as the same as the raised preset.
- The EVENT works only when it was triggered by the external sensor, it will take the parameters defined in EVENT as a guideline, the other undefined parameters will be as the same as the raised preset.
- When you manually raise the scene, the defined parameters in TIMER and EVENT which will not work for manual raising.

SENSOR TRIGGER

In this mode, you may press the button 1~9 to select and edit the external sensor to trigger the scene .

• Preset: 01
• Preset Enable: ON
• Start Time: 08:00
• Stop Time: 09:00

• MAX Limit: 100%
• AMP Volume: 100%
• Folder Select: 01
• Song Select: 03

• Fadetime: 00S
• FM Radio: 97.1

Operation Guide

The user may operate the following actions:

- Preset: selects the scene you want to use the external sensor to trigger
- Preset Enable: to turn on or turn off a scene
- Start Time: to set the time of turning on a scene
- Stop Time: to set the time of turning off a scene
- MAX Limit: to set the max intensity of the LED
- AMP Volume: to set the volume of the amplifier
- Folder Select: to choose the MP3 folder you want to play
- Song Select: to choose the music file you want to play
- Fadetime: to set the fadetime of the sensor triggers the scene
- FM Radio: to set the frequency for the radio

Note:

If the external sensor was triggered during the preset period, the unit will raise the scene in the corresponding period.

The Fadetime may be adjusted in the range of 0~15 seconds.

Can go into to the FM menu directly by shortcut of pressing button "Shift + FM" at a time .

3.4) SET OFF_DELAY

This submenu is used to set the delay time in the range of 0~60S for power on or off the unit.

Set Off delay

00 S