



Mercola.com
Take Control of Your Health

For Mercola.com Customer Service
Call 877-985-2695 or visit support.mercola.com

**STANDUP
TANNING SYSTEM**

User Manual

Warranty

Tanning Systems are warranted to be free from defects in workmanship as follows:

- (5) Years on all metal structural components**
- (1) Year on electrical components**
- (90) Days on lamps**

Dealer's obligation under this warranty is limited to the repair and/or replacement of any defective part without charge for that part, at the manufacturer's discretion, with the following limitations:

- This warranty is extended only to the original purchaser appearing on the sales receipt and is non-transferable.
- This product is designed for use by one person at a time.
- Only original parts may be used.
- All major repairs must be completed by an authorized service representative.
- This warranty does not cover transportation charges on the parts.
- Labor costs are not reimbursable for repair or replacement of items.

Dealer disclaims any responsibility for transportation. Dealer further disclaims any responsibility for injury resulting from the failure of equipment or parts manufactured by due to incorrect installation or operation.

Dealer shall not be liable for loss or damages caused either directly or indirectly from the use of its products. This limited warranty does not extend to any products which have been damaged as a result of accident, misuse, abuse, or as a result of service or modification by anyone other than an authorized service representative.

This warranty does not apply to any failure of parts or products due to alterations, modifications, misuse, abuse, accidents, improper maintenance, or failure to follow the specified electrical requirements. Such occurrences immediately VOID this warranty. THIS WARRANTY IS EXPRESSLY IN LIEU OF ALL OTHER WARRANTIES, EXPRESSED OR IMPLIED, INCLUDING THE WARRANTIES OF MERCHANTABILITY. No person, firm, or corporation is authorized to assume for us any other liability in connection with the sale of these goods

USE OF THIS PRODUCT IN A COMMERCIAL TANNING FACILITY OR FOR PROFESSIONAL AND MEDICAL SERVICES AUTOMATICALLY RESULTS IN THE VOIDING OF ANY AND ALL MANUFACTURER'S WARRANTIES!

THIS PRODUCT IS IN CONFORMITY WITH PERFORMANCE STANDARDS FOR SUN LAMP PRODUCTS UNDER U.S. FDA Section 21 CFR PART 1040.20.

Congratulations

Thank you for choosing our standup tanning system for your tanning pleasure. This tanning system is designed to give you many years of dependable, trouble-free enjoyment in the comfort of your own home.

Table of Contents

Warranty	2
Safety Information	4
Specifications	4
Electrical Requirements	5
Set Up and Assembly Instructions	6-8
Pre-Tanning Guidelines	9
Using The Tanning System	10
Recommended Exposure Times	10
Timer Instructions	10
Care and Maintenance	10
Acrylic Removal and Installation	11-12
Lamp Removal	12
Lamp Maintenance	12
How to Obtain Service	12
Helpful Service Hints	13
Frequently Asked Questions	13
Photosensitivity	14
Pregnancy	15
Record Your Warranty Information	17
Warning Label Information	18

Please read entire manual before attempting to operate this tanning system!

Safety Information

Label Notice: The United States FDA (Food & Drug Administration) requires that a warning label is provided to inform the user of possible dangers as stated in 21 CFR (Code of Federal Regulation), part 1040.20. Review the information on this label located on the front of your tanning system. This information is also provided in this manual (Refer to “Warning Label Information” in the Table of Contents.)

Replacement Lamps: The warning label mentioned above lists the only replacement lamps available for this system. Use of any other lamps voids the warranty.

Tan smart and avoid overexposure. If you do not tan in the sun, you will not tan from this product. As with natural sunlight, overexposure can cause eye and skin injury and allergic reactions. Allow 48 hours between sessions. To ensure optimum smart tanning, please refer to the recommended exposure time chart. (See the Table of Contents.)

Use of certain medications or cosmetics may increase your sensitivity to the ultraviolet radiation. Consult your physician before using any tanning system if you are using medications or have a history of skin problems or believe you are sensitive to sunlight. See “Photosensitivity” (Refer to Table of Contents.)

Recommended eyewear: One pair of protective eyewear, approved by the FDA, is furnished with this equipment. Protective eyewear should be worn by all persons in the room when lamps are on. Failure to wear protective eyewear during each tanning session may result in severe burns or long-term injury to the eyes.



Disconnect power cord before attempting to clean, re-lamp, or engage in the maintenance of this product. This equipment must be earth grounded.



DO NOT operate the tanning system while wet or near water.

Standup Specifications

Size (Height X Width X Thickness)	Weight	Volts	Amps	NEMA Receptacle	Timer*
72" X 24.5" X 2.5"	35 Lbs.	120	8	5-15R 	Mechanical

*This standup tanning system has a maximum exposure time of 10-minutes. Every system comes equipped with an internal 11-minute backup timer. Refer to the table of contents for more information on timers.

Standup Electrical Requirements

The Standup comes equipped with a NEMA 5-15P electrical plug, which requires a NEMA 5-15R receptacle providing 110-120 Volts only!



NEMA 5-15R

Failure to comply with electrical requirements will VOID ALL WARRANTIES and will damage electrical components!



WARNING: HIGH LEAKAGE CURRENT – ENSURE PROPER GROUNDING

WARNING: GROUNDING CIRCUIT CONTINUITY IS VITAL FOR SAFE OPERATION OF EQUIPMENT. NEVER OPERATE EQUIPMENT WITH GROUNDING CONDUCTOR DISCONNECTED



Additionally a very easy way of protecting your tanning unit from potential electrical damage due to power surges or spikes is to **UNPLUG** the unit when **NOT** in use.

**FOR ADDITIONAL ASSISTANCE:
PLEASE REVIEW THE HELPFUL
SERVICE AND MAINTENANCE HINTS IN
THIS USERS MANUAL... IF YOU
HAVE ADDITIONAL QUESTIONS,
REQUIRE TECHNICAL SUPPORT,
ARE INTERESTED IN PURCHASING TANNING
ACCESSORIES/PARTS, OR LAMP UPGRADES
CONTACT THE AUTHORIZED DEALER FROM
WHOM YOU PURCHASED
YOUR TANNING SYSTEM.**

Standup Tanning System Location Requirements

Make sure the room size is at least 6' x 6' x 8' and is well ventilated. Air from the room is used to cool your tanning system which helps to ensure years of trouble free performance. Poor ventilation may cause the system to overheat and cause discomfort to the user as well. Choose a door that will provide adequate structural support and one that is in a traffic free area. Ensure that the power cord can be routed safely to the electrical outlet, and that the door can be fully opened and closed without obstruction and/or damage to the system, walls, door frame etc... If hanging the system on a wall, be sure to choose a location where it can be fastened properly and securely so as to prevent it from falling!

Unpacking Instructions

Your tanning system, brackets and hardware all come in one cardboard box. Upon opening, inspect all items thoroughly for any visible damage. Report any such damage to your Authorized Dealer immediately. Ensure that all hardware and brackets are included. Please note that the brackets and hardware necessary to mount the system on a door are provided.

Standup Assembly Instructions

Tools Required – Phillips screwdriver

Parts List

Item	Description	Quantity
A	Top Bracket	2
B	Bottom Bracket	1
C	Top Bracket Screws (Already screwed into top backside of system)	4
D	Bottom Bracket Thumb Screw (Already screwed into bottom of system)	1
E	Caster	2

Included Brackets and Hardware

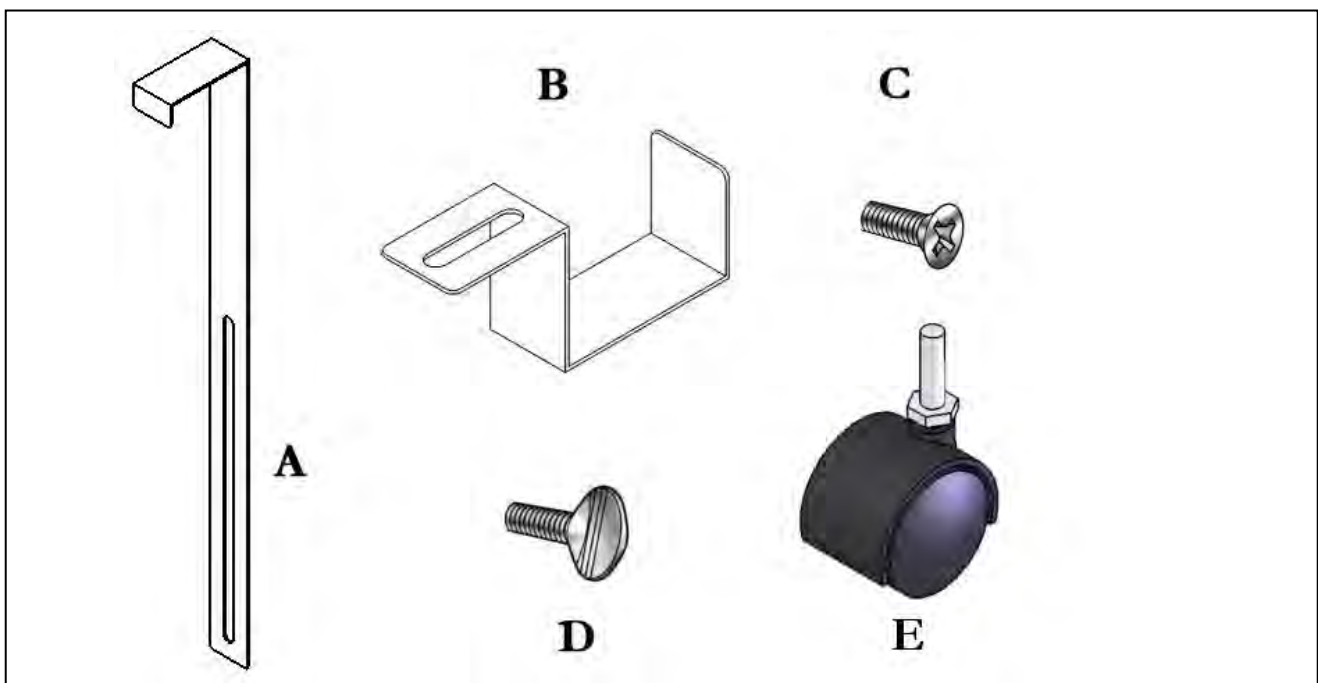

Attaching the Standup to a Door

Before hanging the unit on a door, thread the casters into the inserts at the bottom of the unit (Figure 1b.)

It is very important to ONLY SNUG the casters by hand!

DO NOT TIGHTEN WITH A WRENCH!

Step 1. Remove screws “C” from the back top side of the system, and screw them back in through the slots in the Top Brackets “A” as shown in Figure 1a below, but do not tighten yet.

Step 2. Grasp the Standup firmly with the brackets upright and test fit it on the door.

Step 3. Determine the necessary bracket height to hold the system against the door while allowing the casters to support the weight of the system.

Step 4. Carefully remove the system from the door and tighten screws “C” so the Top Brackets are at the correct height determined in step 3.

Step 5. Slide Bottom Bracket “B” under the door towards the center with the slot on the side that the Standup will hang.

Step 6. Hang the Standup back on the door and ensure a proper fit.

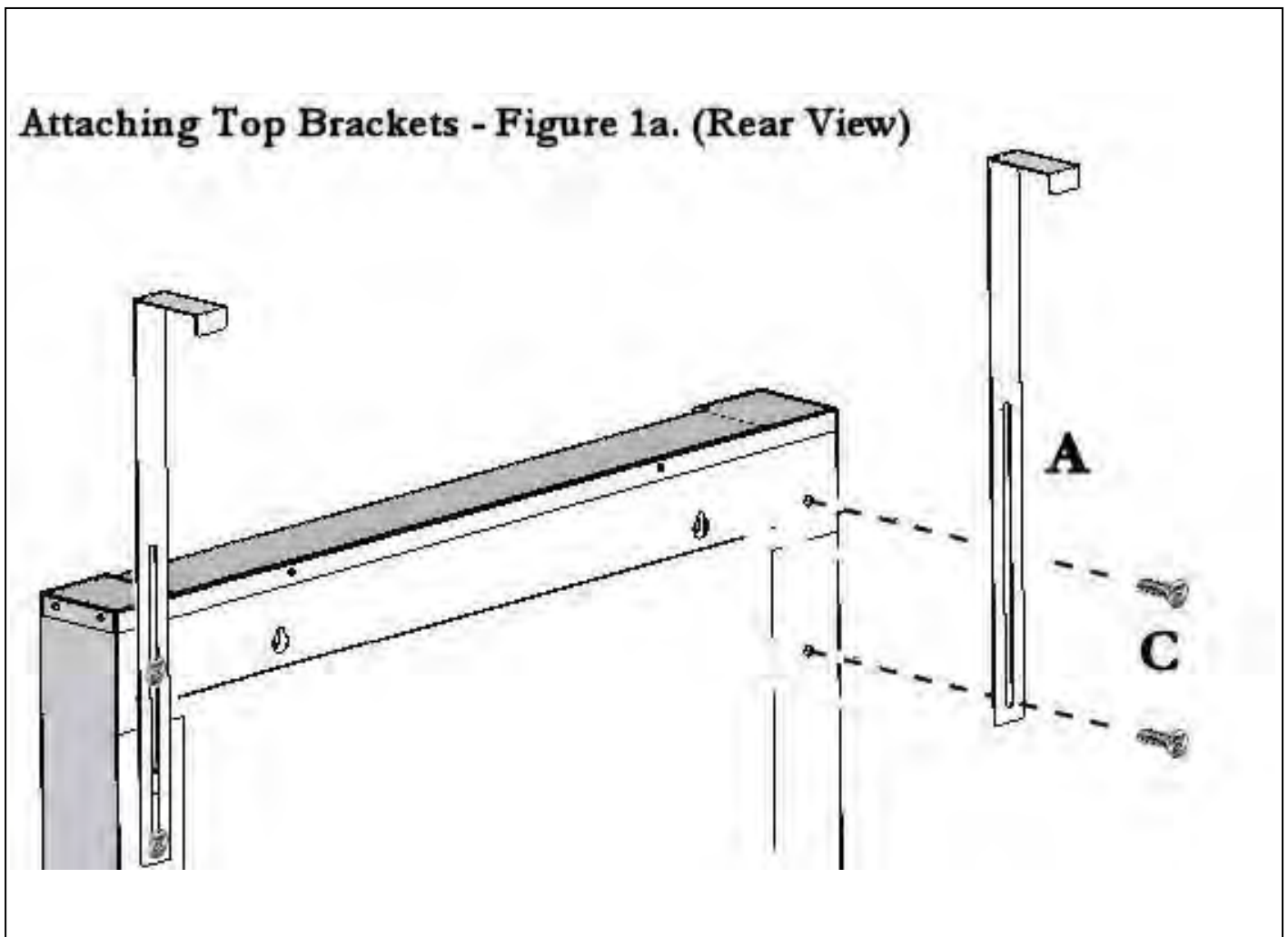

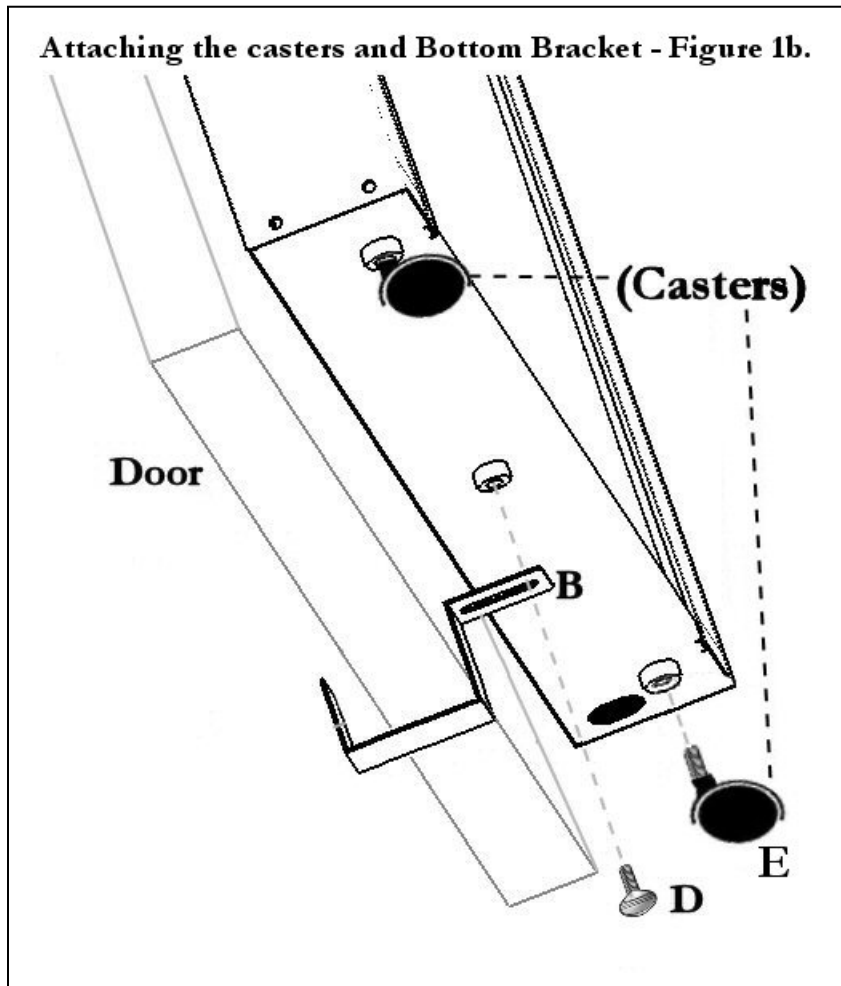

Step 7. Remove the thumb screw “D” from the bottom and screw it back in through the slot in the Bottom Bracket as shown in figure 1b.

Step 8. Slide Bottom Bracket “B” so it clamps the Standup against the door snugly, and tighten the thumb screw.

Optional holes are provided for mounting the Standup on a wall instead of a door (Figure 2.) The brackets, hardware and instructions included are only for mounting the system on a door. Removal of the acrylic and lamps first is recommended if mounting the system on a wall. It is the customer’s responsibility to ensure that the mounting methods and hardware used will safely support 50 lbs. and that it is firmly secured against the wall.

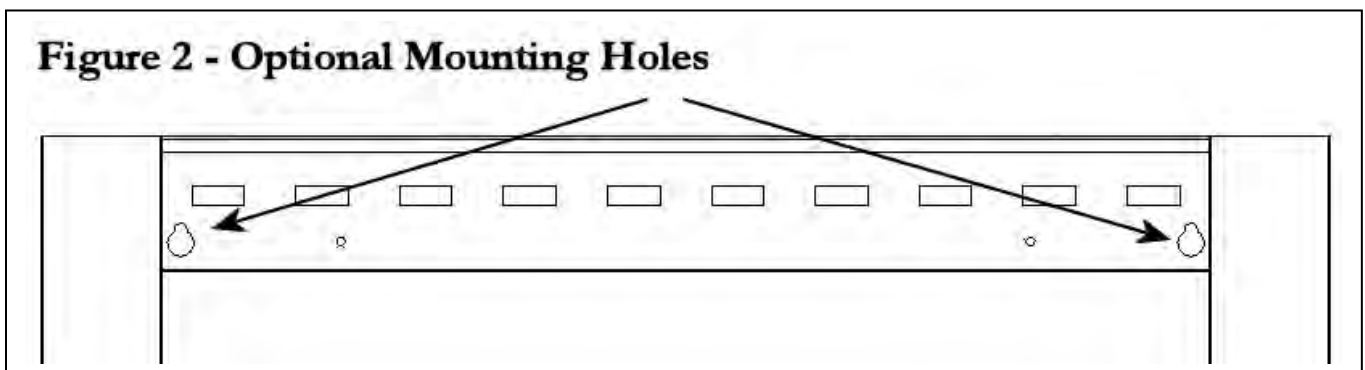

Making the Electrical Connection – refer to electrical requirements. (See Table of Contents.)

Step 1. Plug the three-prong 120 Volt AC power cord into a NEMA 5-15R outlet.

Step 2. Ensure that the cord does not get pinched while the door is opened or closed.

Step 3. Verify that the cord is long enough to allow the door to be fully opened and closed without problems.

Step 4. Ensure that the cord is routed safely away from any traffic or hazards.



NOTE: IT IS BEST TO UNPLUG THE TANNING SYSTEM WHILE NOT IN USE.



DO NOT CONVERT THE POWER CORD TO A TWO PRONG CORD, MODIFY THE CORD IN ANY WAY OR USE ANY EXTENSION CORD.



AS RECOMMENDED FOR ALL ELECTRICAL APPLIANCES, THIS TANNING SYSTEM SHOULD NEVER BE OPERATED NEAR WATER OR WHILE YOU ARE WET.

Pre-Tanning Guidelines

Your Skin

Before tanning, be sure your skin is free of any tanning oils or lotions (except those approved for indoor tanning use), body lotions or cosmetics. Cosmetics or medications applied to your skin may increase your sensitivity to ultraviolet light. If you are taking any medication, or if you are especially sensitive to sunlight, we recommend that you consult a physician before using this or any tanning equipment. It is also recommended that you not bathe immediately before using this tanning system as it removes natural body oils which protect your skin.

Your Eyes

FDA approved eye goggles are provided with this tanning system and must be worn whenever the tanning system is operating. Regular sunglasses do not adequately protect your eyes from ultraviolet light.

FDA approved eye shields should be worn while tanning and by everyone in the room while the tanning system is in operation.



DO NOT OPERATE the tanning system near water or while you are wet!

Using the Tanning System

This tanning system is designed for use by one person at a time. This tanning system operates via a mechanical timer. Determine the recommended exposure time according to your skin type. See chart below.

Recommended Exposure Times – Standup models. Shown in Minutes				
Skin Type:	Week 1	Week 2	Week 3	Week 4
I. Sensitive skin: burns easily and severely, does not tan	Not recommended for tanning!			
II. Light: burns easily and severely, tans minimally	2	3	4	5
III. Normal: burns moderately, tans average	3	4	5	7
IV. Dark: burns minimally, tans easily and above average	4	6	8	10
MAXIMUM EXPOSURE TIME IS 10 MINUTES				

ALLOW 48 HOURS BETWEEN TANNING SESSIONS!

10 Minute Mechanical Timer Instructions

Standup models are equipped with mechanical timers.

To begin tanning, refer to the recommended exposure time chart above

- Step 1. If using indoor tanning lotion, apply before turning on the system. Your Authorized Dealer can assist you with the proper tanning lotion for your skin type.
- Step 2. Put on goggles.
- Step 3. Turn timer clockwise to desired time. The timer will not allow more than 10 minutes.
- Step 4. Stand no closer than two inches from the lamps.

When the timer reaches 0, the lamps will automatically shut off.



Do not turn the timer backwards. This will damage the timer.

Automatic Shut-off Timer

Your tanning system is equipped with a backup shut-off timer which will automatically turn off the tanning system after 10 minutes. This important safety feature prevents the user from resetting the timer before the end of the pre-set maximum time interval.

Caring For and Maintaining Your Tanning System

THE TANNING SYSTEM SHOULD BE COMPLETELY SHUT DOWN AND UNPLUGGED FROM THE POWER SOURCE AT LEAST TWO (2) FULL HOURS BEFORE ANY CLEANING OR MAINTENANCE TO ALLOW THE TANNING SYSTEM TO ADEQUATELY COOL DOWN!!!!

Preventive Maintenance for Your Tanning System				
Recommended Care	After Each Session	Monthly	6 Months	Every 1000 hours
Clean goggles	x			
Clean exterior of system		x		
Inspect/clean lamps			x	
Replace lamps				x

Cleaning and Maintenance



Warning. *Disconnect the tanning system from electrical power before cleaning, changing lamps or performing service.*

When cleaning the tanning system, use a cotton towel which is much less abrasive than a paper towel. Never wipe with a dry cloth, as this will generate a slight static, which attracts dust.

Acrylic Removal



Warning. *Disconnect system from electrical power before servicing.*

Step 1. Remove thumb screw “D” (Figure 1b.)

Step 2. Carefully lift the standup system off of the door and set horizontal on the floor.

Step 3. Slide the acrylic out of the top end of the system as shown in figure 3.

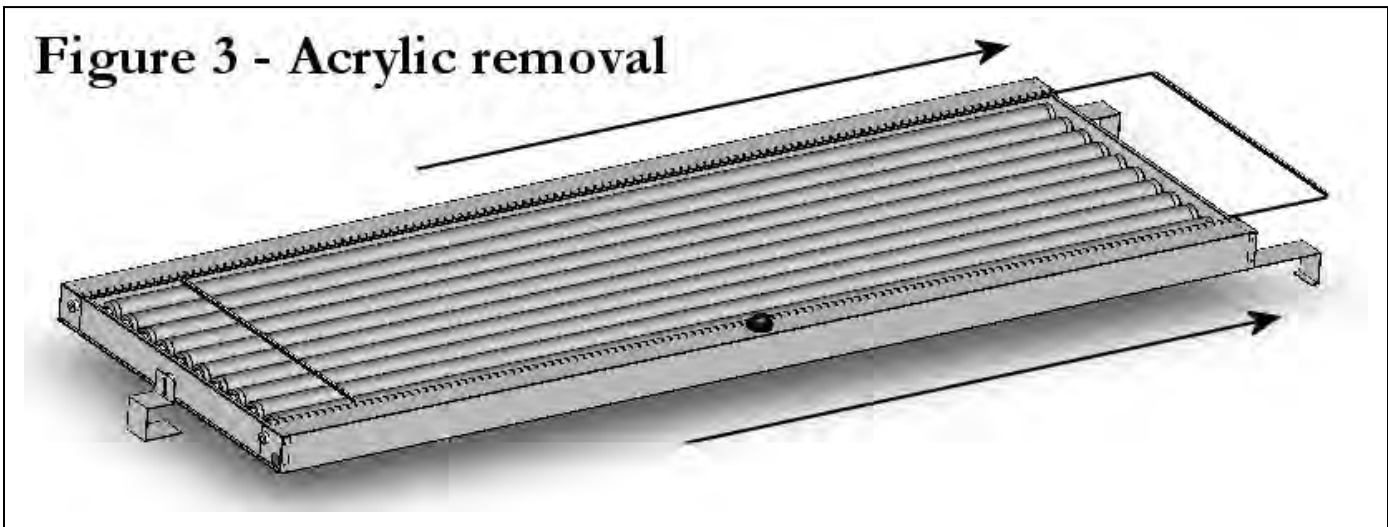

Acrylic Installation

- Step 1. Slide the acrylic in through the grooves at the top of the system.
- Step 2. Pull it down evenly until it seats at the bottom of the system.
- Step 3. Carefully hang the system on the door or wall again and tighten the thumb screw at the bottom.

Lamp Removal & Installation

The lamps are rated up to 1000 hours of use. You may elect to change lamps sooner.

Step 1. After removing acrylic, grasp a lamp at one end and at middle. Turn the lamp a quarter turn. The lamp may then be gently removed from its holder.

Step 2. Hold lamp with the label facing toward the acrylic and to the top side of the system. To install the lamp, insert the pins located on the ends of the lamp into the slots on top of the lamp holder and turn the lamp a quarter turn to hold in place. Make sure that the writing on the lamp faces the acrylic.

For lamp replacement, refer to “Lamp Cleaning” section to follow. Lamps used longer than 1000 hours have lost their tanning power even though they will continue to light.

Only the lamps shown on the warning label have been certified by the United States FDA for use in this standup tanning system. Refer to the sticker on the front of the system and/or the Warning Label Information in this manual. (See Table of Contents.)



Do not use lamps other than those specified. To do so will void your warranty and FDA certification.

You may purchase tanning lamps from your Authorized Dealer.

Lamp Cleaning & Replacement

Depending on the amount of usage, it is recommended that you clean your lamps every six months. For acrylic removal instructions, refer to table of contents. After all the lamps have been removed, use a soft cloth and a non-abrasive cleaner to wipe down the tanning system. Gently wipe the entire length of the lamp with a damp cloth to remove any film buildup.

How to Obtain Service

1. Review the “Helpful Service Hints” to follow.
2. If you require additional assistance, contact the Customer Service Department at the Authorized Dealer where the system was purchased. If it becomes necessary to replace a warranty part, proof of purchase is required to obtain warranty service. ***It is important to keep your store receipt.***
3. For non-warranty parts replacement or for routine maintenance, contact your Authorized Dealer.

Helpful Service Hints	
Lamps will not light	<ul style="list-style-type: none"> • Is the tanning system on using the timer system? • Is the tanning system plugged into the electrical receptacle? • Check the power supply. You may have to reset the circuit breaker. • Verify that the voltage coming out of the wall is safe for this product. Your voltage should not exceed 120 Volts. • The lamp may not be locked into place. You may need to hand twist back into locking position • The lamp may be burnt out. Removal of the acrylic may be needed. Refer to the Acrylic Removal section of this manual. Remove a lamp that lights and place it in the spot where the lamp was out. If this new lamp doesn't light in this position the ballast may need to be replaced. If it does light, the first lamp may need to be replaced.
Several lamps located next to each other are not lit	A ballast may require replacement, due to a power surge in your household electrical system. Contact your Authorized Dealer for replacement assistance.

Frequently Asked Indoor Tanning Questions?

May I tan daily?

No. US FDA guidelines specify to allow 48 hours between tanning sessions.

Do tanning lotions really make you tan faster?

Yes. Depending on your skin type, when you use the appropriate accelerator, you will achieve a darker tan in less time than if using no accelerator.

How many times do I have to use the system before I get a tan?

That depends on your skin type and how fast you tan. It will probably take you approximately 16 sessions to achieve the results you want. (See recommended exposure time chart.)

Do I have to take my contact lenses out before I tan?

No, if you wear protective FDA approved eyewear.

Do I really have to wear Goggles?

Yes. DO NOT use a tanning system without eye protection. Your eyes may be damaged by the UV rays. FDA approved goggles that you wear are very important. Your eyelids alone offer no protection against ultraviolet light, which may cause damage to the eye. Not using proper eye protection may also result in red, tired, itchy eyes, headaches and loss of night vision.

Nude Tanning

Parts of the body that have never been exposed to the sun before will turn pink or even red. They might even break out with a rash. This is caused by an over-exposure to the ultraviolet rays. It takes these parts longer to start the tanning process.

Rashes

Heat rashes, or “tanner’s itch”, indicate that the light and heat generated by tanning bulbs or the sun have dried your skin. Itching can also result from a reduced rate of melanin production in a particular area of your body. Melanin is the protective skin pigment found in varying amounts in everyone’s skin. If you begin tanning in the nude, you may find that previously unexposed areas develop an itch. This is natural so don’t be alarmed; just discontinue tanning for a few days, and then slowly build up time allowing melanin production to increase. Heat rashes may also have a slight redness and itching, which occurs from getting too many UV rays. It’s dryness of the skin or reactions to cosmetics, medications or foods that may contribute to this. If a medication, irritation, cosmetic or food is causing the rash, you should stop tanning until the rash disappears.

Photosensitivity

A photosensitivity reaction does not depend on the presence or absence of a suntan or sunburn, although it often accompanies them. Photosensitivity reactions are immunological or toxicity reactions and result from the presence of photosensitizing agents and UV light. Photosensitivity reactions are characterized by reddish skin with elevated poison ivy-like bumps and can occur in areas that were not exposed to the sun. They frequently produce little or no discomfort. On the other hand, phototoxic reactions, another type of photosensitivity reaction, are usually accompanied by symptoms similar to that of sunburn. Once a person gets a photosensitivity reaction, they are more likely to have a recurrence under the same conditions in the future. (Mayo Clinic 1993).

Symptoms of Photosensitivity

Usually severe burning. Often occurs in patches and in small areas of the body.

Blotch formation. Could be a result of heat as well as light.

Rash (Photodermis). Redness induced by light. May be the cause of itching and may appear all over the body.

Uneven pigmentation. Could be the result of light exposure combined with medication, or it might be the result of non-light related factors such as genetic factors, pressure points or a fungus. Fungus will only show up when you tan. It looks like small white spots that do not tan. Selsun Blue® dandruff shampoo will usually take care of it. Put a cap full or two in your bath water and soak for 30 minutes a day for two consecutive days.

Common diseases which react unfavorably with UV light (are exacerbated by UV):

Herpes Simplex, Lupus Erythematosus (swelling of the nerve endings), Porphyria-severe (extreme sensitivity to any source of light), Vitiligo (irregularly shaped patches of skin with no pigmentation and dark borders), Skin cancers (Basal, Squamous, and Melanoma)



Below is a partial list of medicines that can cause a photosensitivity reaction (meaning you might turn red or burn when taking them with exposure to the sun or a tanning system):

IF YOU ARE TAKING ANY MEDICATIONS, CONSULT WITH YOUR DOCTOR BEFORE TANNING!

Antibiotics in the Tetracycline Family

**Anticancer Drugs
Anticonvulsants
Antidepressants
Antidiabetics
Antihistamines
Antihypertensive Medications
Antiseptic Creams
Birth Control Pills
Retin-A
Sulfonamides (often for urinary tract infections)
Tranquilizers
Water Pills**

Medications to avoid when tanning

**Acne medications
Antibacterial Drugs
Antibiotics
Anticancer Drugs
Antidepressants
Antihistamines
Anti-inflammatory Drugs
Antiparasitic Drugs
Birth Control Pills
Diabetes Drugs
Diuretics
Psoralen Drugs (topical or oral)
Tranquilizers/Antipsychotic Drugs**

Anyone with Basal Cell & Squamous Cell Carcinomas (directly linked to UV Rays) should not use a tanning system. Similarly, anyone with malignant melanoma (when unsure whether it is caused by the sun) should also avoid exposure to any UV rays (indoor or outdoor).

Pregnancy

You should consult with your doctor before tanning while pregnant.

FOR ADDITIONAL ASSISTANCE:

**PLEASE REVIEW THE HELPFUL
SERVICE AND MAINTENANCE HINTS
IN THIS USERS MANUAL...**

**IF YOU HAVE ADDITIONAL
QUESTIONS...
REQUIRE TECHNICAL SUPPORT...
INTERESTED IN PURCHASING
TANNING ACCESSORIES...
OR FUTURE UPGRADES FOR NEW
LAMPS...**

**PLEASE CONTACT THE AUTHORIZED
DEALER FROM WHOM YOU
PURCHASED YOUR TANNING
SYSTEM.**

Warranty Information

USE OF THIS PRODUCT IN A COMMERCIAL TANNING FACILITY OR FOR PROFESSIONAL AND MEDICAL SERVICES AUTOMATICALLY RESULTS IN THE VOIDING OF ANY AND ALL MANUFACTURER'S WARRANTIES!

Record and retain this information for ease of service:

Authorized Dealer Name _____
Store Address _____
City _____ State _____ Zip Code _____
Phone _____
Salesperson _____
Date of Purchase _____
Standup Serial Number _____

Attach your receipt to this manual.

Warning Label Information

DANGER Ultraviolet radiation. Follow instructions. Avoid overexposure. As with natural sunlight, overexposure can cause eye and skin injury and allergic reactions. Repeated exposure may cause premature aging of the skin and skin cancer. **FAILURE TO WEAR PROTECTIVE EYEWEAR MAY RESULT IN SEVERE BURNS OR LONG-TERM INJURY TO THE EYES.**

WARNING: Read the instruction booklet before using this sunlamp product. All persons in the room should wear protective eyewear when lamps are on. Recommended eyewear: Provided eye shields or equivalent eyewear as defined under 21CFR 1040.20. Other types of eyewear may not provide adequate protection. If discomfort develops, discontinue use and consult a physician.

Medications or cosmetics may increase your sensitivity to the ultraviolet radiation. Consult physician before using sunlamp if you are using medications or have a history of skin problems or think you are especially sensitive to sunlight. If you do not tan in the sun, you are unlikely to tan from the use of this product. Children, the elderly, or fair skinned people who always burn easily and either never tan or tan minimally, should not use this equipment.

To use, stand up in front of system maintaining at least 2 inches between your body and lamps, to avoid overexposure.

Never tan more than once a day and allow 48 hours between tanning sessions. Tanning normally appears after the first few sessions and maximizes after approximately four weeks. Tan once or twice per week thereafter to maintain desired appearance.

ONLY THE FOLLOWING LAMPS HAVE BEEN CERTIFIED FOR USE IN THIS EQUIPMENT:

Solara ReNew (532005)
Solara Supreme (532003)
Solara Supreme ReFresh (532009) or
Sunergy Selectra VHO (533125)
Sunergy Selectra VHO (533125)
Solara Supreme ReFresh (532009)

RECOMMENDED EXPOSURE TIMES – IN MINUTES MAXIMUM EXPOSURE TIME IS 10 MINUTES

SKIN TYPE	WEEK:	1	2	3	4
1 Sensitive Skin (Burns easily and severely and does not tan)	NOT RECOMMENDED FOR TANNING				
2 Light (Burns easily and severely and tans minimally.)		2	3	4	5
3 Normal (Burns Moderately and tans average.)		3	4	5	7
4 Dark (Burns minimally, tans easily and above average.)		4	6	8	10

Disconnect power cord before attempting to clean, relamp, or engage in the maintenance of this product.

This product is in conformity with performance standards for sun lamp products under 21 CFR Part 1040.20 and ANSI/UL Standard 482.

Made in the U.S.A.